



US00D621326S

(12) **United States Design Patent**
Bauer et al.

(10) **Patent No.:** **US D621,326 S**

(45) **Date of Patent:** **** Aug. 10, 2010**

(54) **CONVERTIBLE TOP COVER AND ROLL BAR FOR A VEHICLE**

(75) Inventors: **Karlheinz Bauer**, Esslingen (DE);
Mark Fetherston, Stuttgart (DE);
Hans-Dieter Futschik, Gechingen (DE);
Holger Hutzenlaub, Boeblingen (DE);
Steffen Koehl, Stuttgart (DE); **Frank Pfisterer**, Weil der Stadt (DE); **Marco Schulz**, Holzgerlingen (DE)

(73) Assignee: **Dimaler AG**, Stuttgart (DE)

(**) Term: **14 Years**

(21) Appl. No.: **29/309,076**

(22) Filed: **Jun. 18, 2008**

(30) **Foreign Application Priority Data**

Dec. 21, 2007 (EM) 000849450-0004

(51) **LOC (9) Cl.** **12-06**

(52) **U.S. Cl.** **D12/222**

(58) **Field of Classification Search** D12/400,
D12/401, 404, 406, 412, 414, 222, 223, 86,
D12/93, 101; 224/923, 924; 211/100, 124,
211/2, 4, 85.7; D6/552

See application file for complete search history.

(56) **References Cited**

U.S. PATENT DOCUMENTS

D194,665 S * 2/1963 Bordinat, Jr. D12/401

D337,554 S * 7/1993 Lucas D12/401
D347,205 S * 5/1994 Huisman D12/222
D373,985 S * 9/1996 Weaver et al. D12/401
D374,651 S * 10/1996 Townsend D12/401
D388,385 S * 12/1997 Protz, Sr. D12/167
D391,547 S * 3/1998 Lehmann et al. D12/401
D399,476 S * 10/1998 Duncan D12/222
D487,719 S * 3/2004 Powers D12/401

* cited by examiner

Primary Examiner—Caron Veynar

Assistant Examiner—Katrina A Kile

(74) *Attorney, Agent, or Firm*—Crowell & Moring LLP

(57) **CLAIM**

The ornamental design for a convertible top cover and roll bar for a vehicle, as shown and described.

DESCRIPTION

FIG. 1 is a left rear perspective view of a convertible top cover and roll bar for a vehicle according to our novel design, the right rear perspective view being mirror symmetrical;

FIG. 2 is a front view thereof;

FIG. 3 is a top view thereof; and,

FIG. 4 is a left side view thereof, the right side view being mirror symmetrical.

In the drawings, the broken lines depict portions of a convertible top cover and roll bar for a vehicle and form no part of the claimed design.

1 Claim, 2 Drawing Sheets

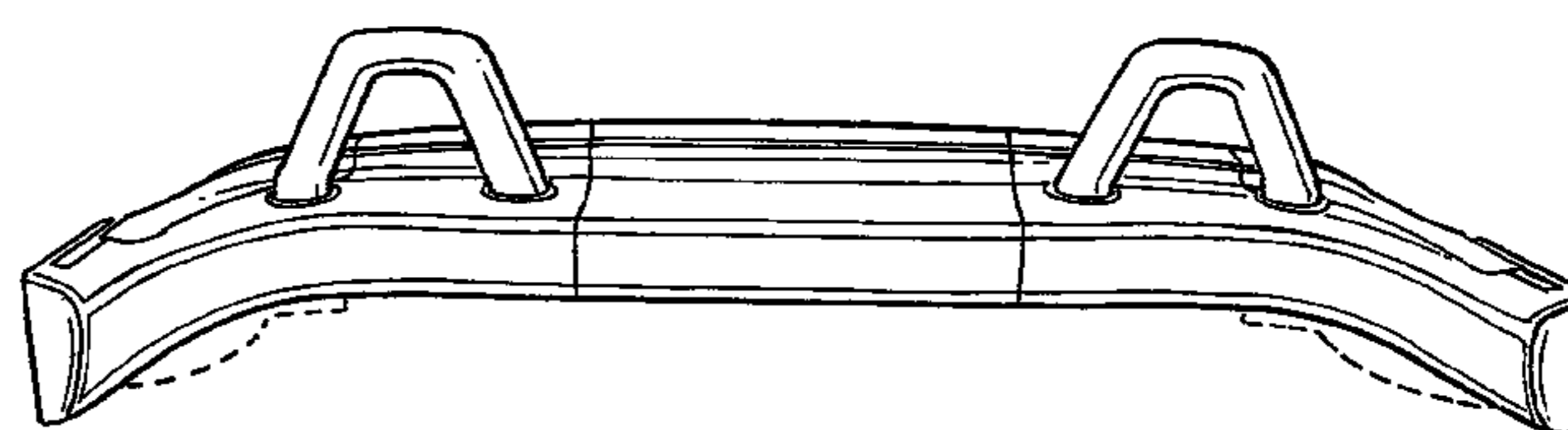
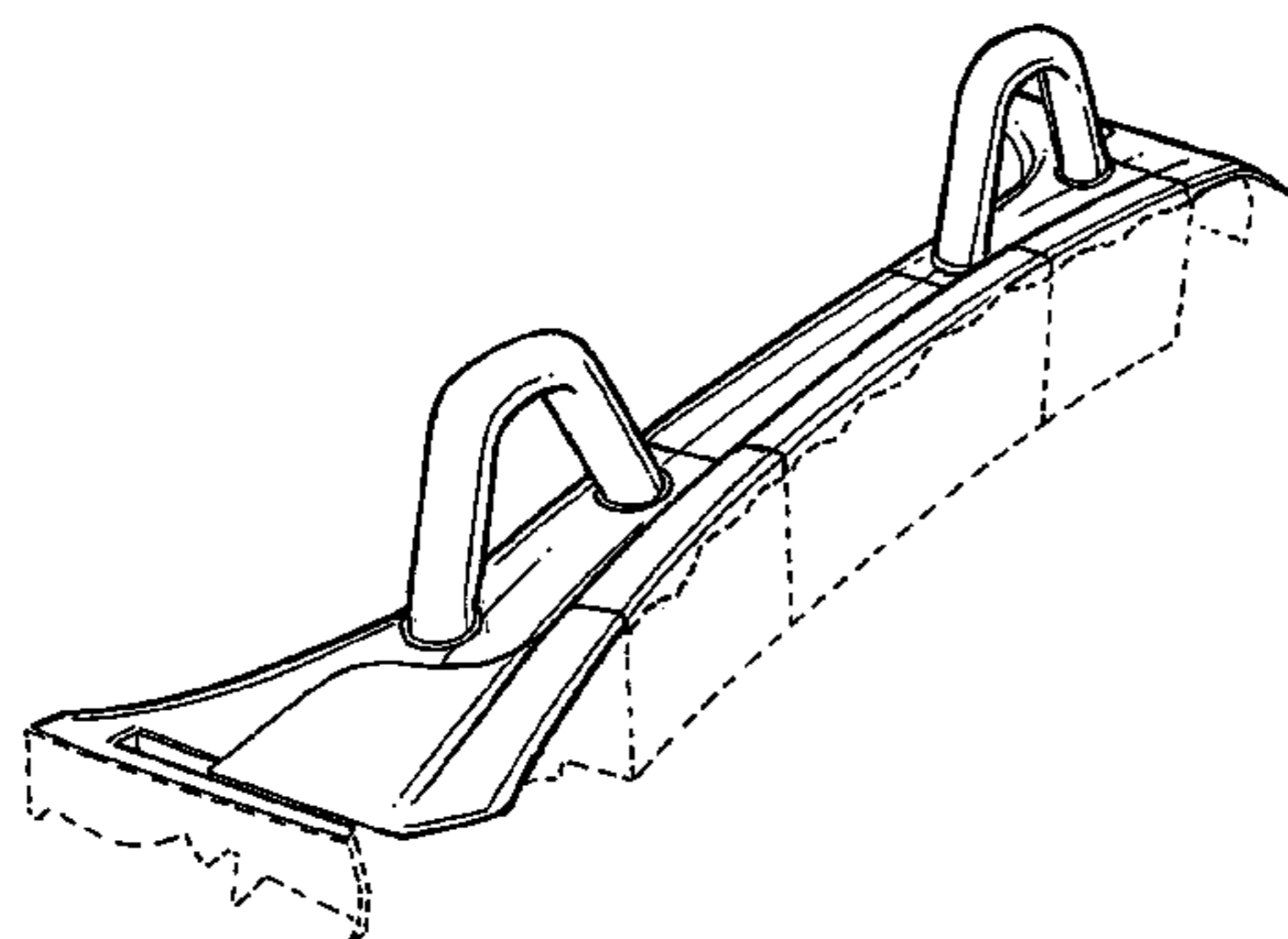

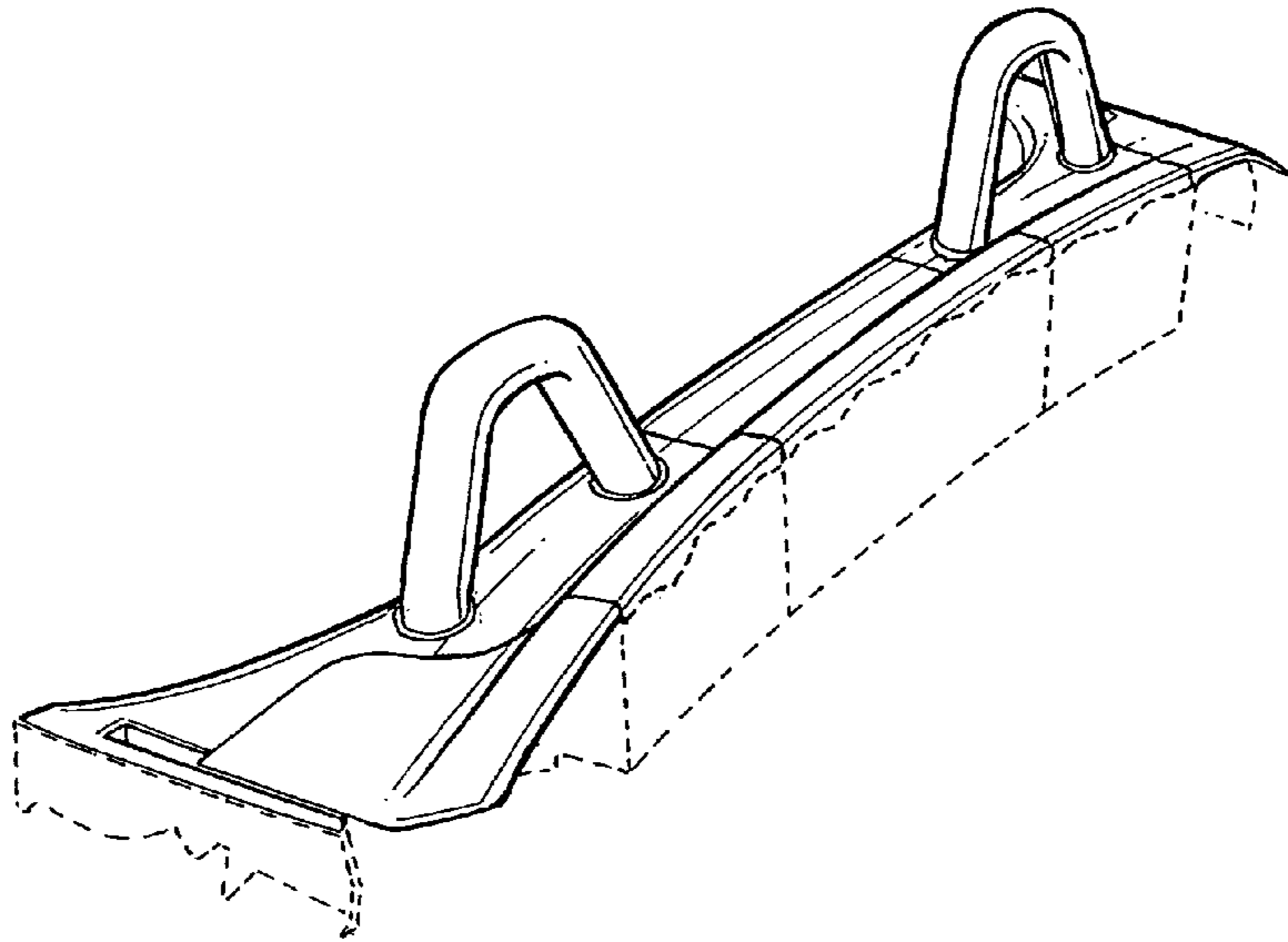

FIG . 1

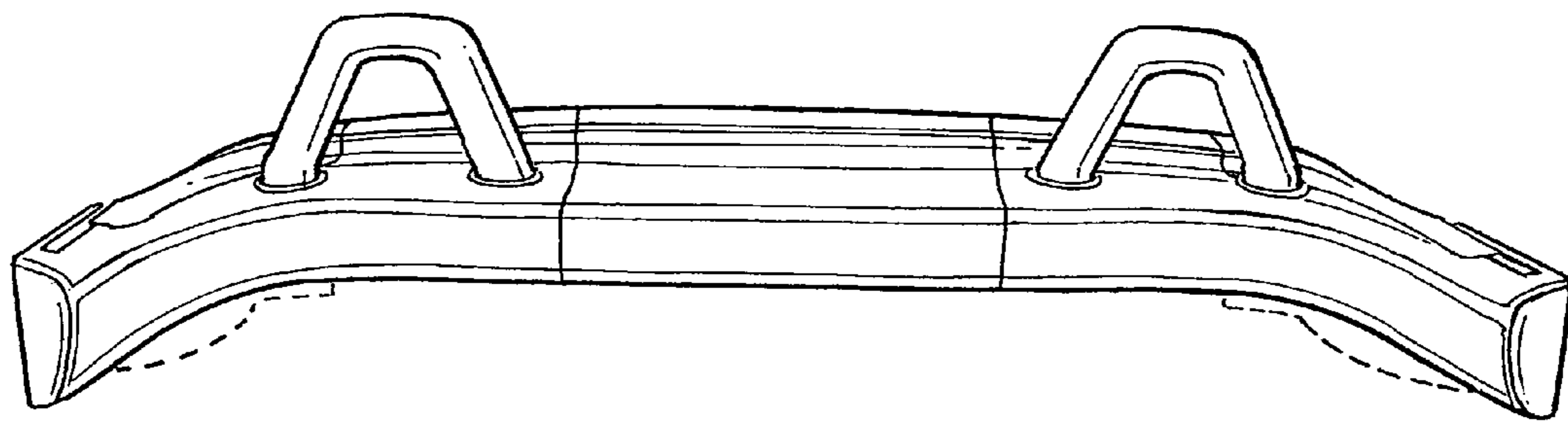

FIG . 2

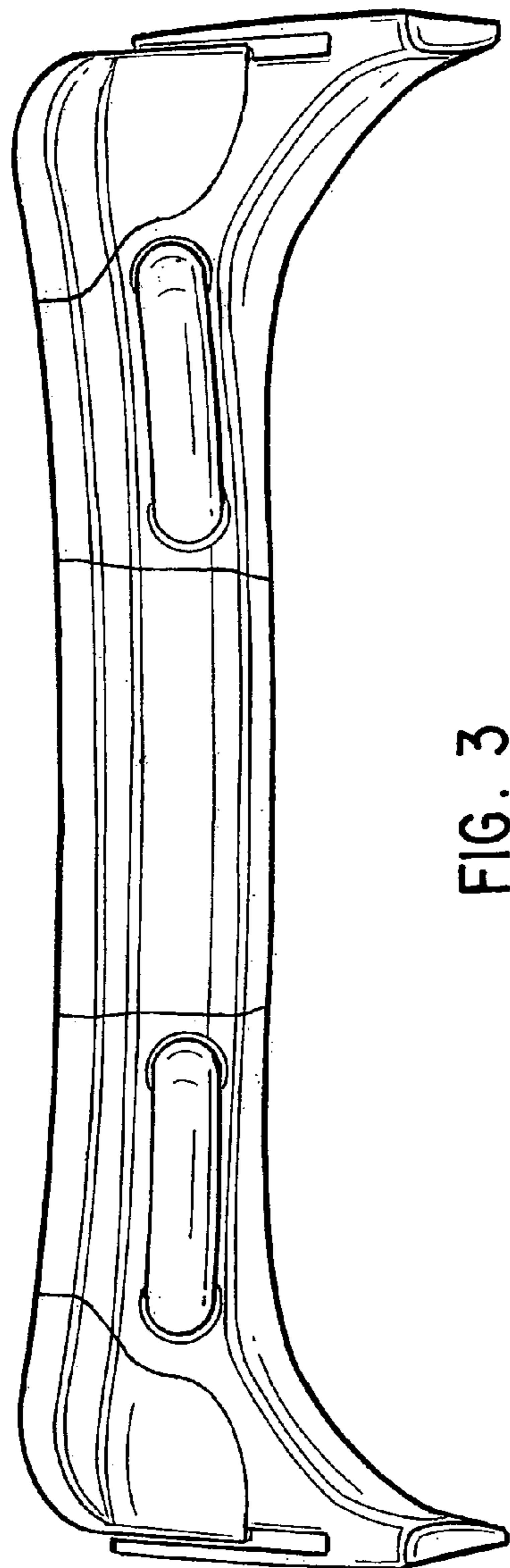

FIG. 3

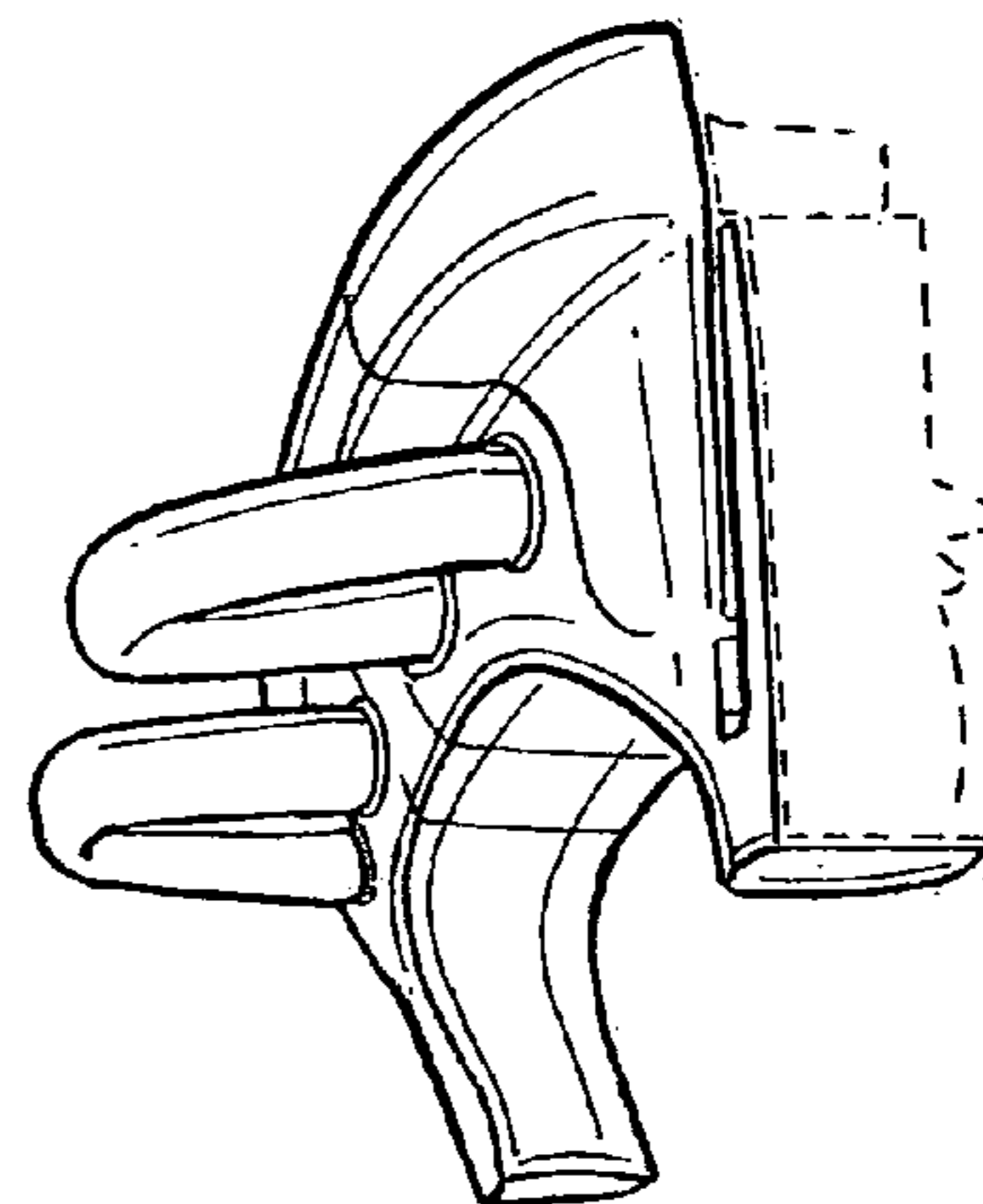

FIG. 4