



US00D621286S

(12) **United States Design Patent**
Liao

(10) **Patent No.:** **US D621,286 S**

(45) **Date of Patent:** **** Aug. 10, 2010**

(54) **SCOREBOARD FOR A GOLF CLUB CART**

D419,275 S * 1/2000 Carter D34/38
D449,544 S * 10/2001 Liu D10/46.1
D467,510 S * 12/2002 Hung D10/46.1

(75) Inventor: **Gordon Liao, Yung Kang (TW)**

* cited by examiner

(73) Assignee: **Unique Product & Design Co., Ltd.,
Yung Kang (TW)**

Primary Examiner—Prabhakar Deshmukh

(**) Term: **14 Years**

(74) *Attorney, Agent, or Firm*—Alan Kamrath; Kamrath & Associates PA

(21) Appl. No.: **29/330,038**

(57) **CLAIM**

(22) Filed: **Dec. 27, 2008**

The ornamental design for the scoreboard for a golf club cart, as shown and described.

(51) **LOC (9) Cl.** **21-01**

(52) **U.S. Cl.** **D10/46.1**

(58) **Field of Classification Search** D10/46,
D10/46.1; 116/222–225; 224/918, 921;
473/131; 236/90

See application file for complete search history.

DESCRIPTION

FIG. 1 is a perspective view of the scoreboard for a golf club cart showing my new design;

FIG. 2 is a front elevational view thereof;

FIG. 3 is a left side elevational view thereof;

FIG. 4 is a right side elevational view thereof;

FIG. 5 is a top plan view thereof; and,

FIG. 6 is a bottom plan view thereof.

The broken line showing of the scoreboard for a golf club cart is for illustrative purposes only and forms no part of the claimed design.

(56) **References Cited**

U.S. PATENT DOCUMENTS

1,771,593	A *	7/1930	Tell	235/1 B
1,817,778	A *	8/1931	Sperr, Jr.	423/225
2,838,238	A *	6/1958	Menes	235/113
D281,797	S *	12/1985	Tong	D21/561
D360,595	S *	7/1995	Lia	D10/46.1
5,620,099	A *	4/1997	Bickett et al.	206/579
D412,855	S *	8/1999	Wu	D10/46.1

1 Claim, 4 Drawing Sheets

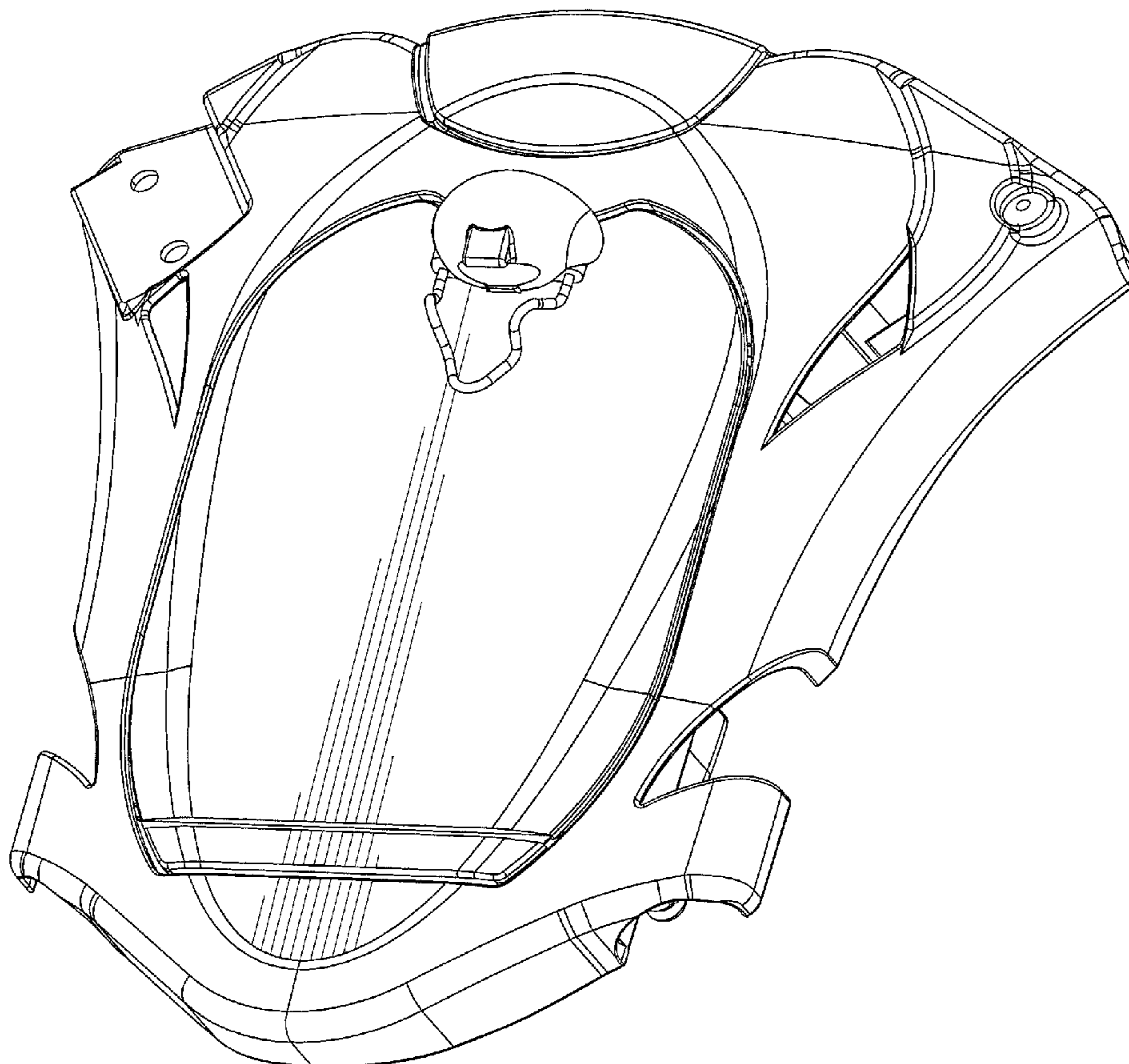

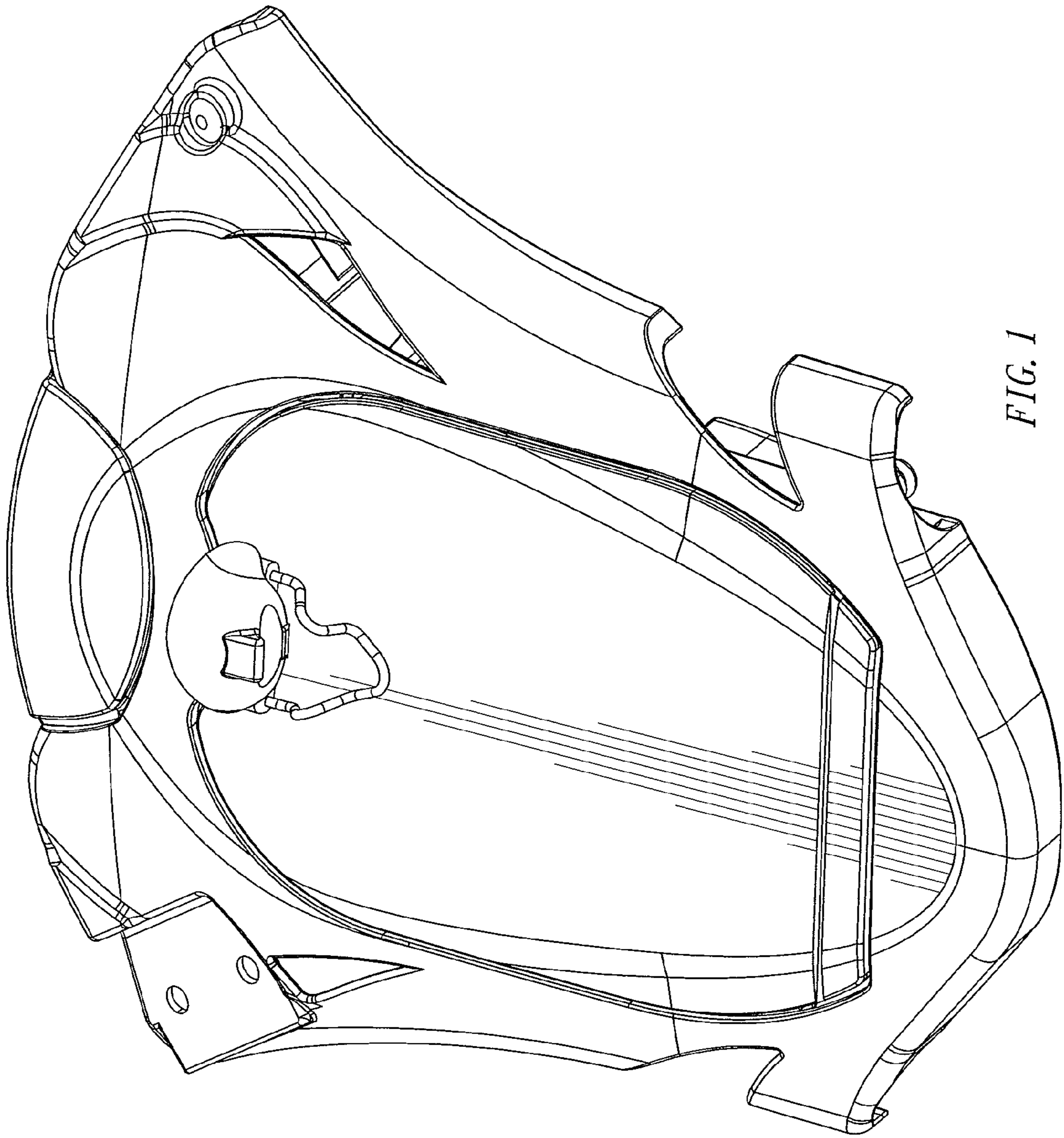

FIG. 1

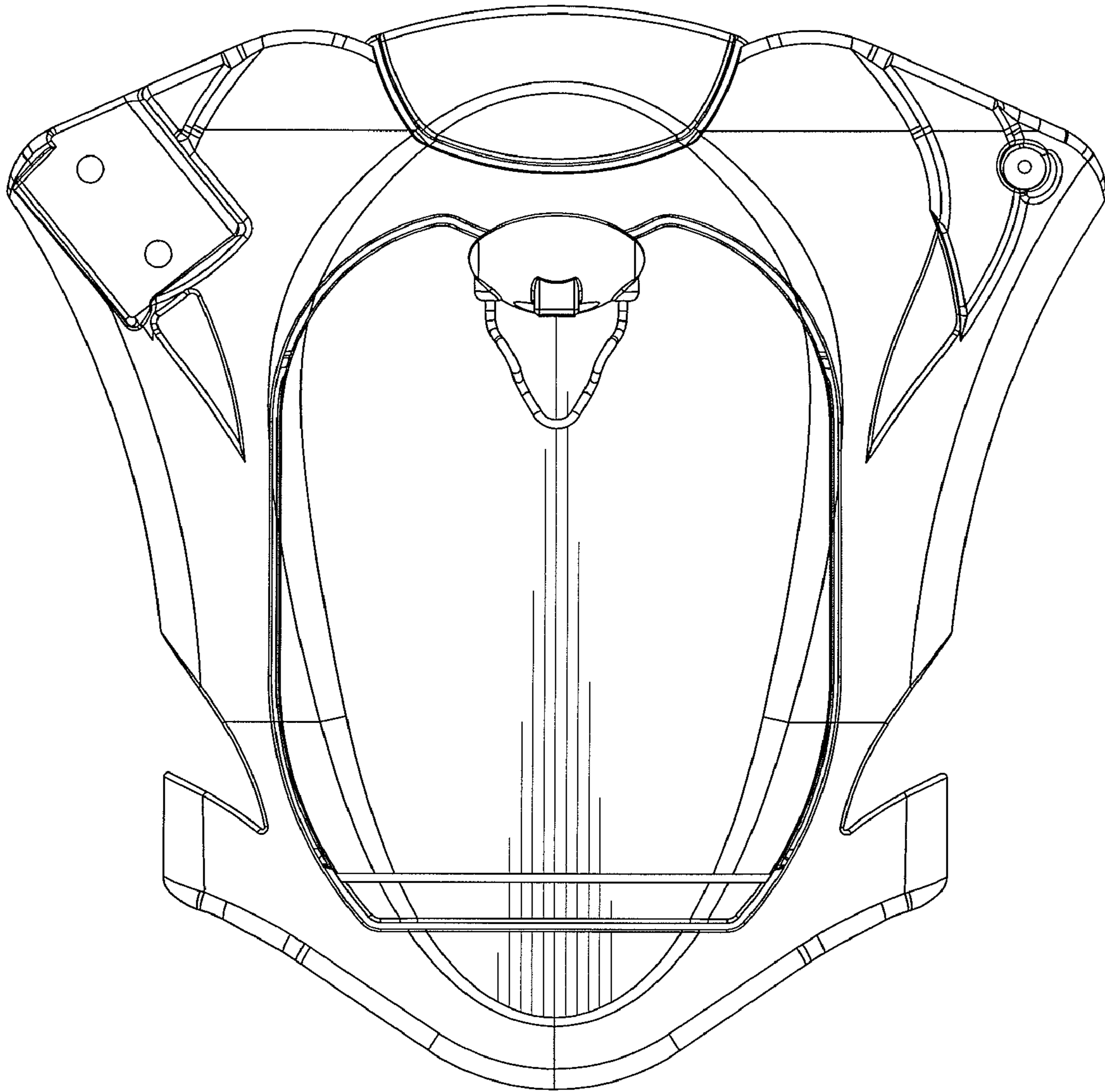

FIG. 2

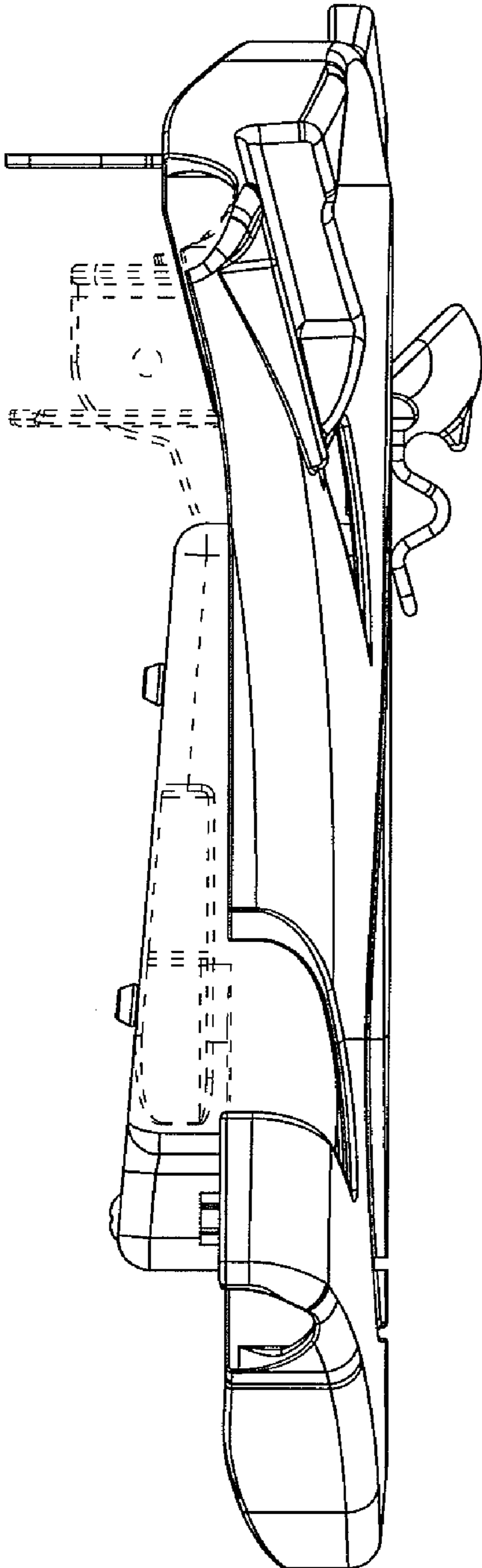

FIG. 3

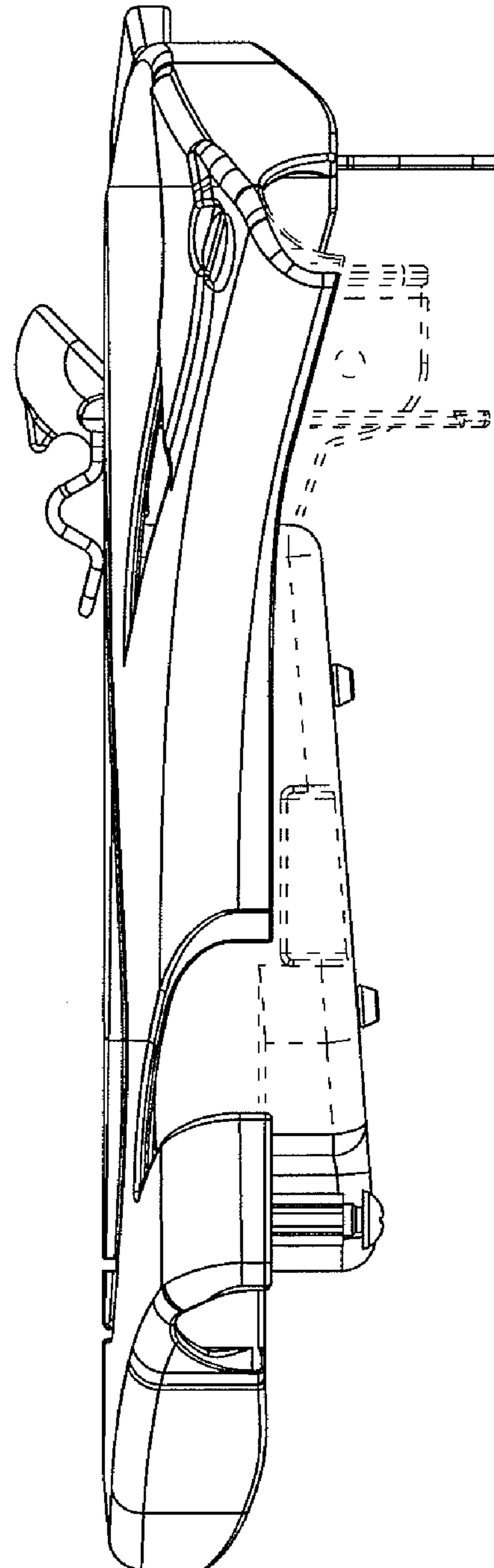

FIG. 4

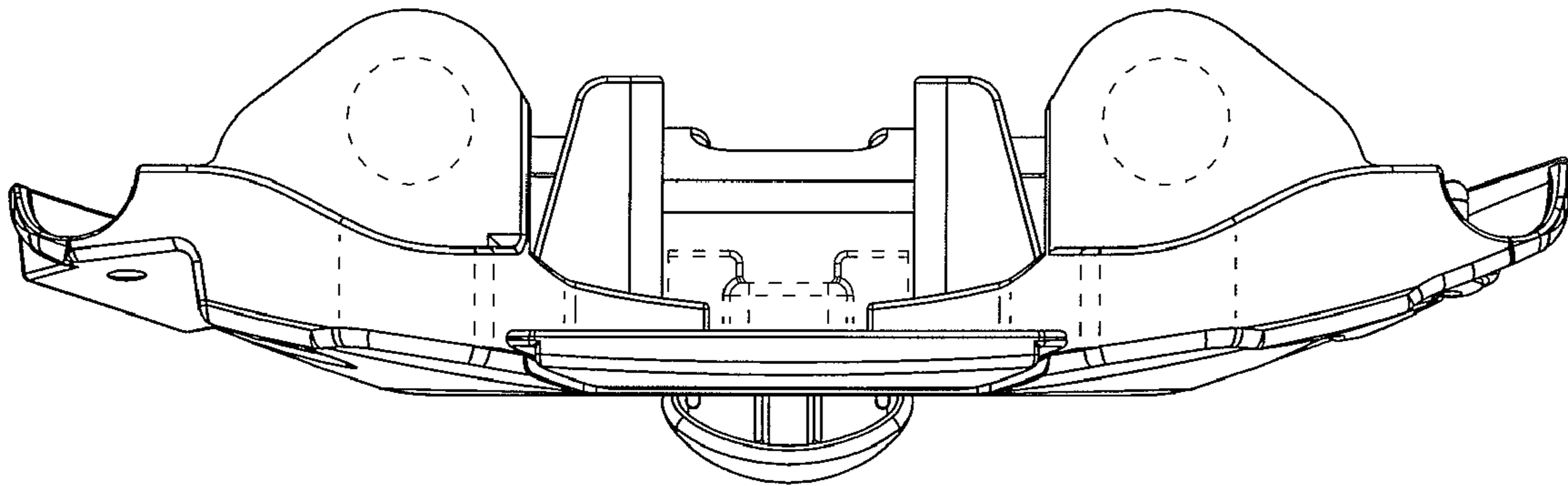

FIG. 5

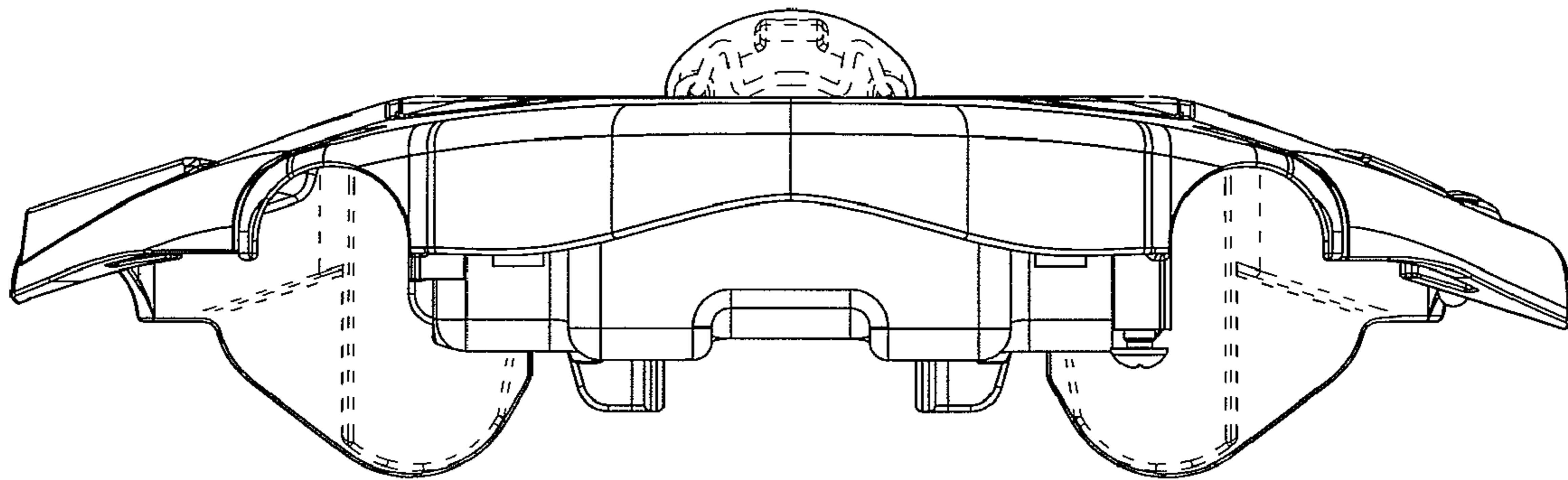

FIG. 6