



US00D621041S

(12) **United States Design Patent**
Mao et al.

(10) **Patent No.:** **US D621,041 S**
(45) **Date of Patent:** **** Aug. 3, 2010**

(54) **PORTION OF NERVE ROOT RETRACTOR WITH SENSOR**

(75) Inventors: **Jimmy Jian-min Mao**, Fremont, CA (US); **Robert E. Lash**, Redwood City, CA (US)

(73) Assignee: **ViOptix Inc.**, Fremont, CA (US)

(**) Term: **14 Years**

(21) Appl. No.: **29/321,092**

(22) Filed: **Jul. 10, 2008**

Related U.S. Application Data

(60) Division of application No. 29/284,745, filed on Sep. 14, 2007, now Pat. No. Des. 574,955, which is a continuation-in-part of application No. 29/281,422, filed on Jun. 22, 2007, now Pat. No. Des. 582,034.

(51) **LOC (9) Cl.** **24-02**

(52) **U.S. Cl.** **D24/135**

(58) **Field of Classification Search** D24/133, D24/135, 140, 147; 600/201, 202, 210, 227, 600/212, 215, 206, 245, 226, 235; 606/160, 606/84

See application file for complete search history.

(56) **References Cited**

U.S. PATENT DOCUMENTS

- 3,394,700 A 7/1968 Yamamoto
- 4,049,000 A 9/1977 Williams
- 4,190,042 A 2/1980 Sinnreich
- 4,226,228 A * 10/1980 Shin et al. 600/206
- D275,227 S 8/1984 Garner, Jr.
- 4,597,382 A 7/1986 Perez, Jr.
- 4,738,248 A 4/1988 Ray
- 4,883,426 A * 11/1989 Ferrer 433/91
- 4,919,616 A 4/1990 Croll
- 4,959,067 A 9/1990 Muller
- D312,306 S 11/1990 Michelson
- D318,116 S 7/1991 Michelson
- 5,123,403 A 6/1992 Lavyne

- 5,520,611 A 5/1996 Rao et al.
- 5,769,781 A * 6/1998 Chappuis 600/202
- 5,803,904 A 9/1998 Mehdizadeh
- 5,891,018 A 4/1999 Wells
- D411,883 S * 7/1999 Farascioni et al. D24/135
- D430,668 S 9/2000 Koros et al.
- D433,134 S 10/2000 Pitesky
- D442,687 S 5/2001 Schulz
- D443,056 S 5/2001 Koros et al.
- D453,377 S 2/2002 Schollhorn et al.
- D457,957 S 5/2002 Sanford et al.
- 6,416,465 B2 7/2002 Brau
- 6,860,850 B2 * 3/2005 Phillips et al. 600/227
- 6,875,173 B2 * 4/2005 Suddaby 600/210
- D510,768 S 10/2005 Farley
- 6,994,548 B2 2/2006 Perret, Jr.
- 7,226,413 B2 6/2007 McKinley
- D574,493 S * 8/2008 Lash et al. D24/135
- D575,398 S * 8/2008 Lash et al. D24/135
- D578,647 S * 10/2008 Lash et al. D24/135
- D582,034 S * 12/2008 Lash et al. D24/135
- D593,201 S * 5/2009 Lash et al. D24/135
- D603,046 S * 10/2009 Frey D24/146
- 2004/0193018 A1 * 9/2004 Thalgott et al. 600/227

OTHER PUBLICATIONS

Nerve Root Retractors, Codman Surgical Product Catalog 380-385 (2004).

* cited by examiner

Primary Examiner—Ian Simmons

Assistant Examiner—Charles D Hanson

(74) *Attorney, Agent, or Firm*—Aka Chan LLP

(57) **CLAIM**

The ornamental design for a portion of a nerve root retractor with sensor, as shown and described.

DESCRIPTION

FIG. 1 shows a perspective view of a design for a portion of a nerve root retractor with sensor.

FIG. 2 shows a right side view of the design.

FIG. 3 shows a left side view of the design.

FIG. 4 shows a top view of the design.

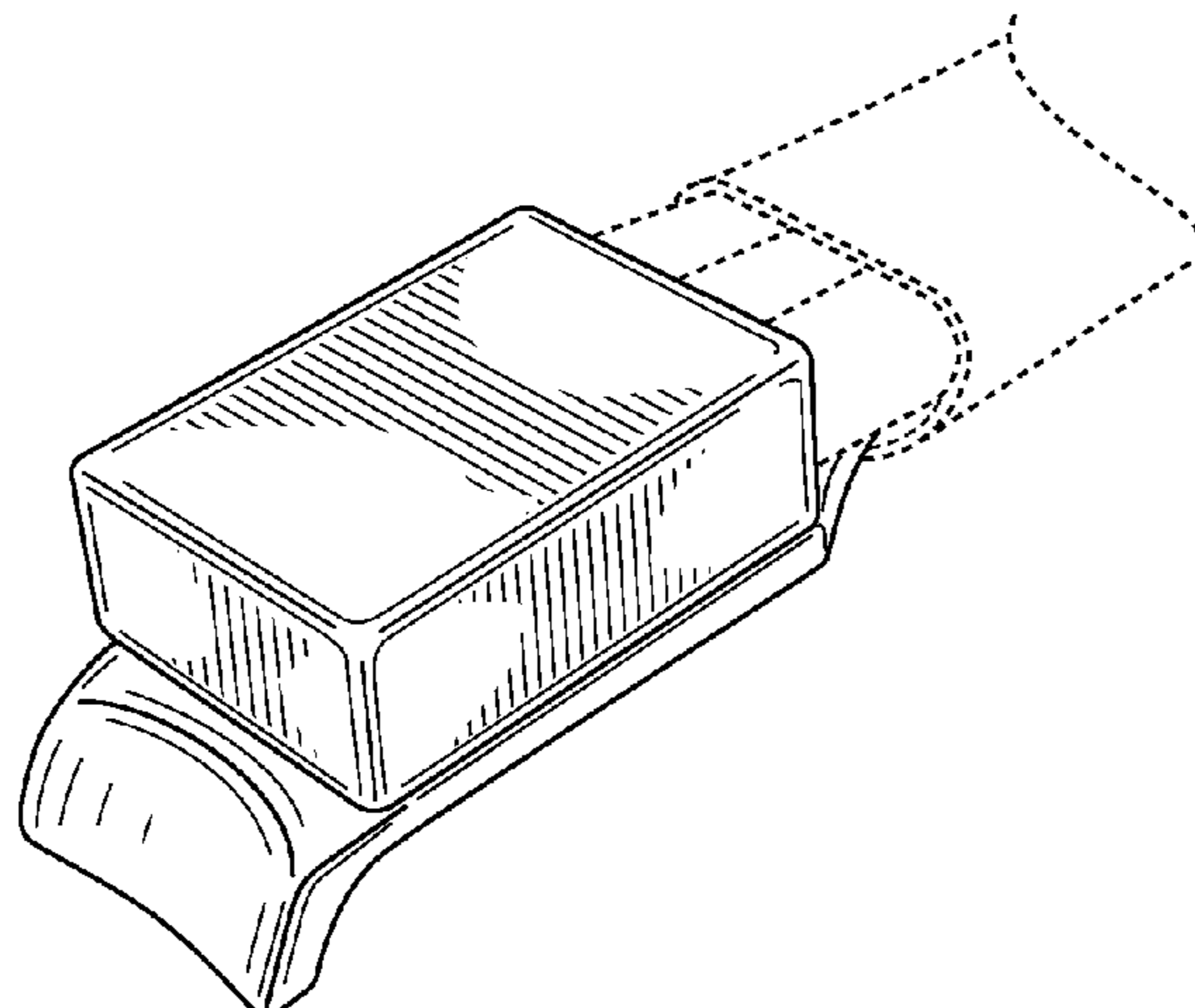

FIG. 5 shows a front view of the design.

FIG. 6 shows a first alternate bottom view of the design.

FIG. 7 shows a second alternate bottom view of the design.

FIG. 8 shows a third alternate bottom view of the design.

FIG. 9 shows a fourth alternate bottom view of the design.

FIG. 10 shows a fifth alternate bottom view of the design.

FIG. 11 shows a sixth alternate bottom view of the design.

FIG. 12 shows a seventh alternate bottom view of the design.

FIG. 13 shows an eighth alternate bottom view of the design.

FIG. 14 shows a ninth alternate bottom view of the design.

FIG. 15 shows a tenth alternate bottom view of the design.

FIG. 16 shows an eleventh alternate bottom view of the design.

FIG. 17 shows a twelfth alternate bottom view of the design.

FIG. 18 shows a thirteenth alternate bottom view of the design.

FIG. 19 shows a fourteenth alternate bottom view of the design.

FIG. 20 shows a fifteenth alternate bottom view of the design.

FIG. 21 shows a sixteenth alternate bottom view of the design.

FIG. 22 shows a seventeenth alternate bottom view of the design.

FIG. 23 shows an eighteenth alternate bottom view of the design.

FIG. 24 shows a nineteenth alternate bottom view of the design.

FIG. 25 shows a twentieth alternate bottom view of the design.

FIG. 26 shows a twenty-first alternate bottom view of the design.

FIG. 27 shows a twenty-second alternate bottom view of the design.

FIG. 28 shows a twenty-third alternate bottom view of the design.

FIG. 29 shows a twenty-fourth alternate bottom view of the design; and,

FIG. 30 shows a twenty-fifth alternate bottom view of the design.

Other views of FIGS. 7-30 (alternate bottom views) are the same as in FIGS. 1-5.

The broken-line features in the figures are for illustrative purposes only and form no part of the claimed design.

1 Claim, 11 Drawing Sheets

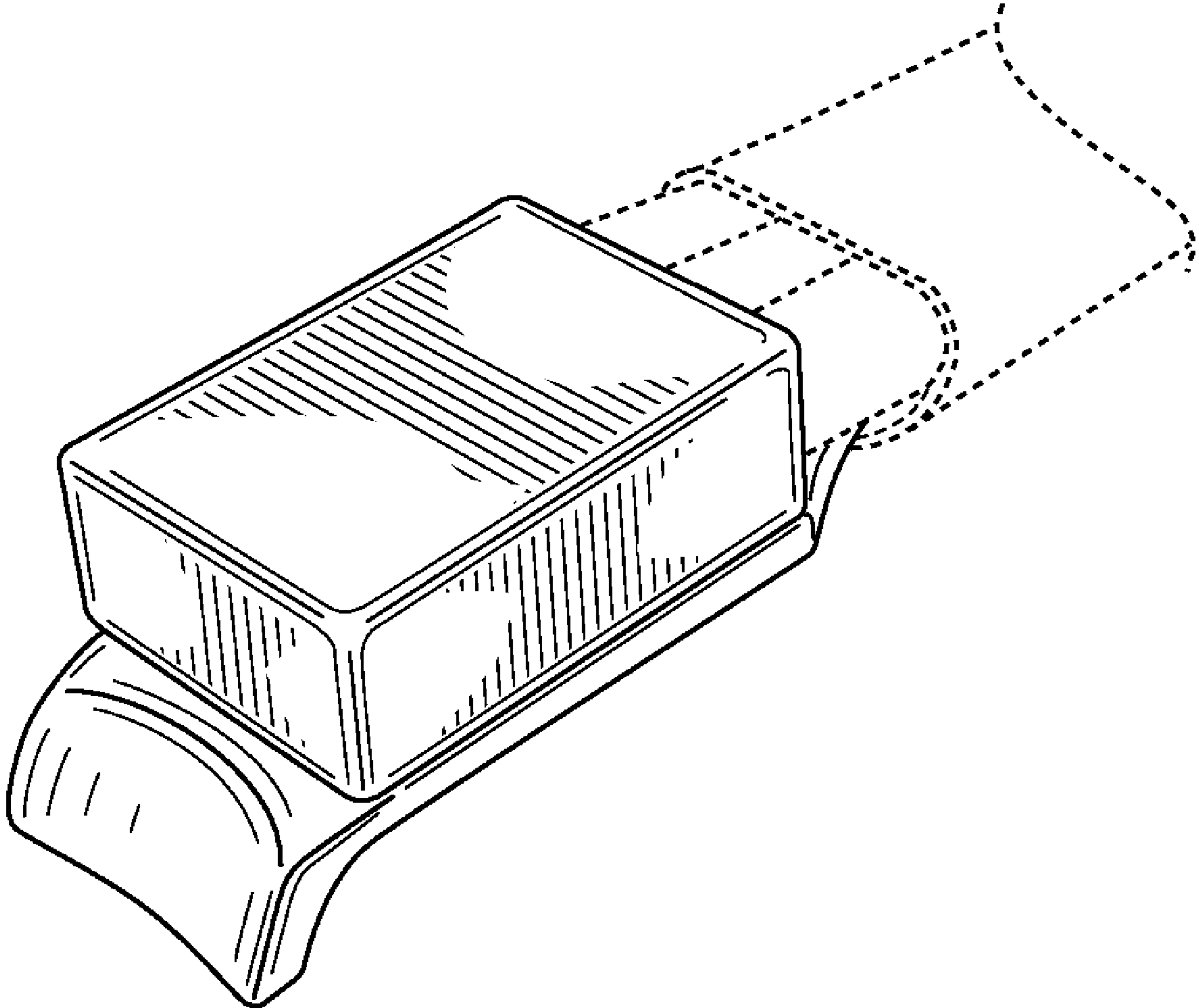

FIG. 1

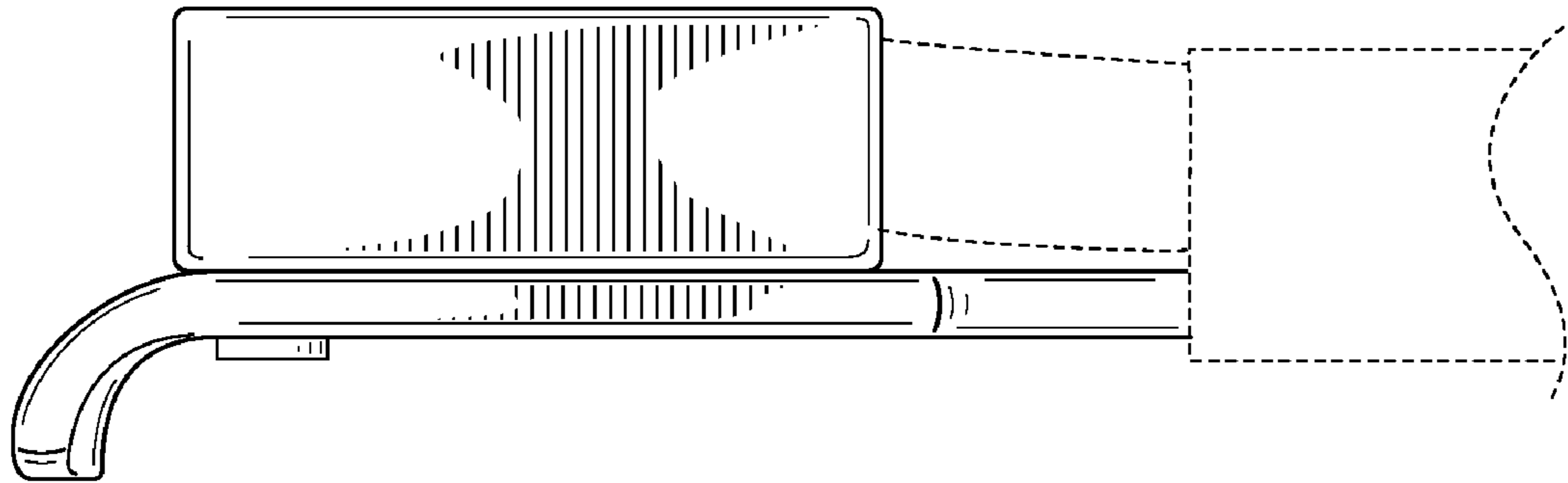

FIG. 2

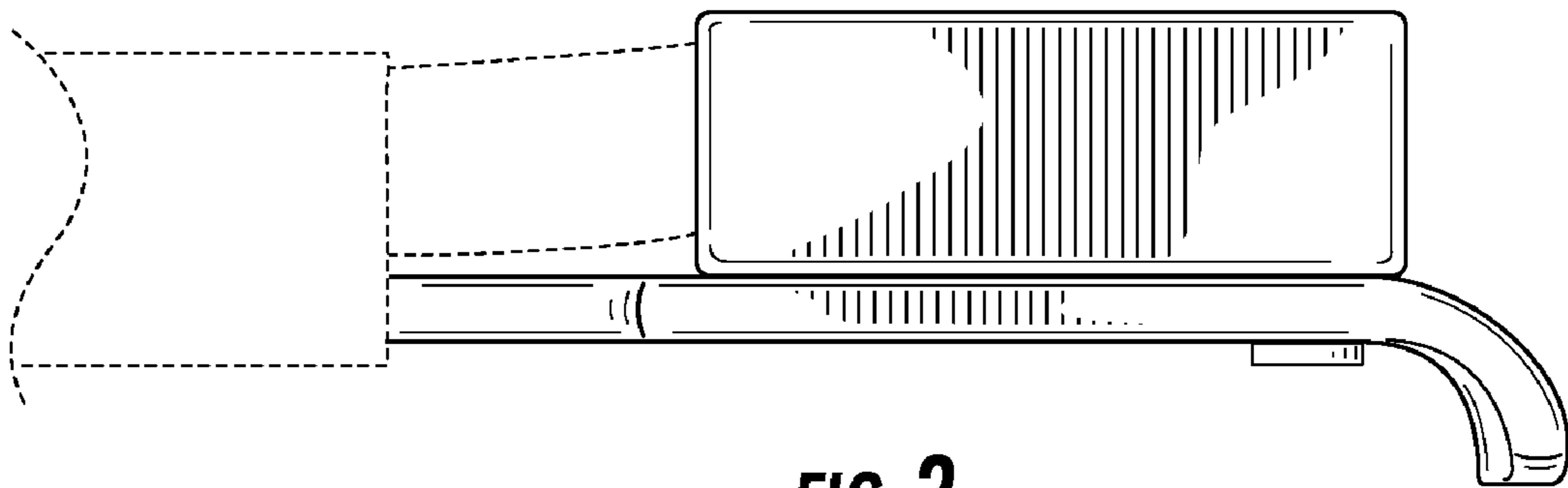

FIG. 3

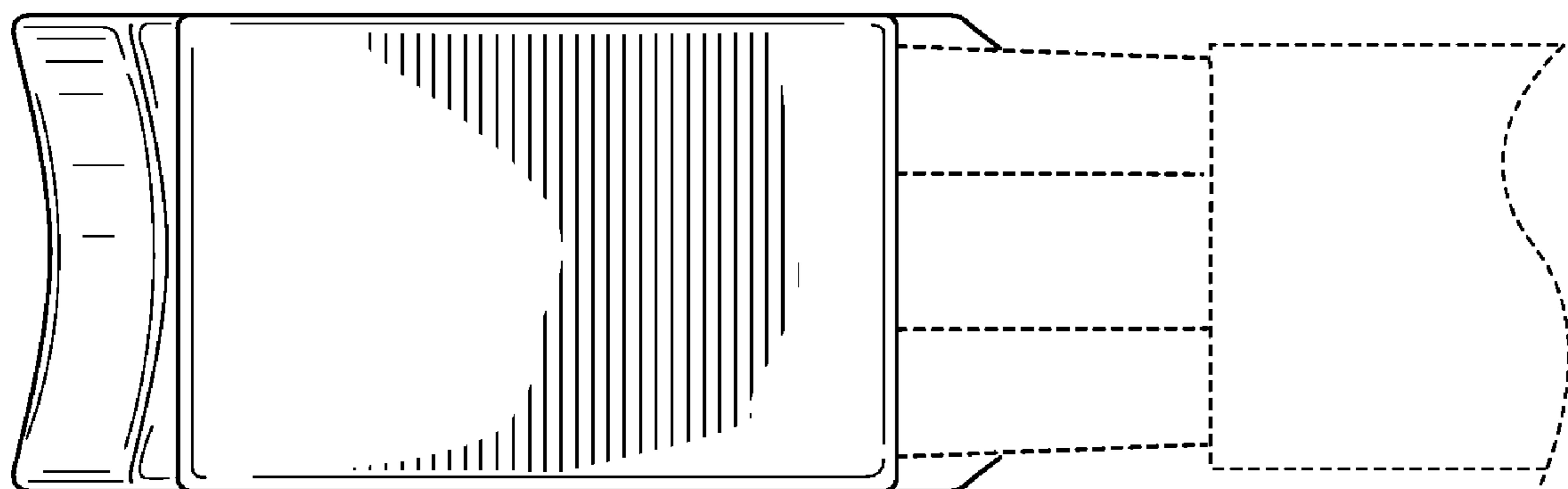

FIG. 4

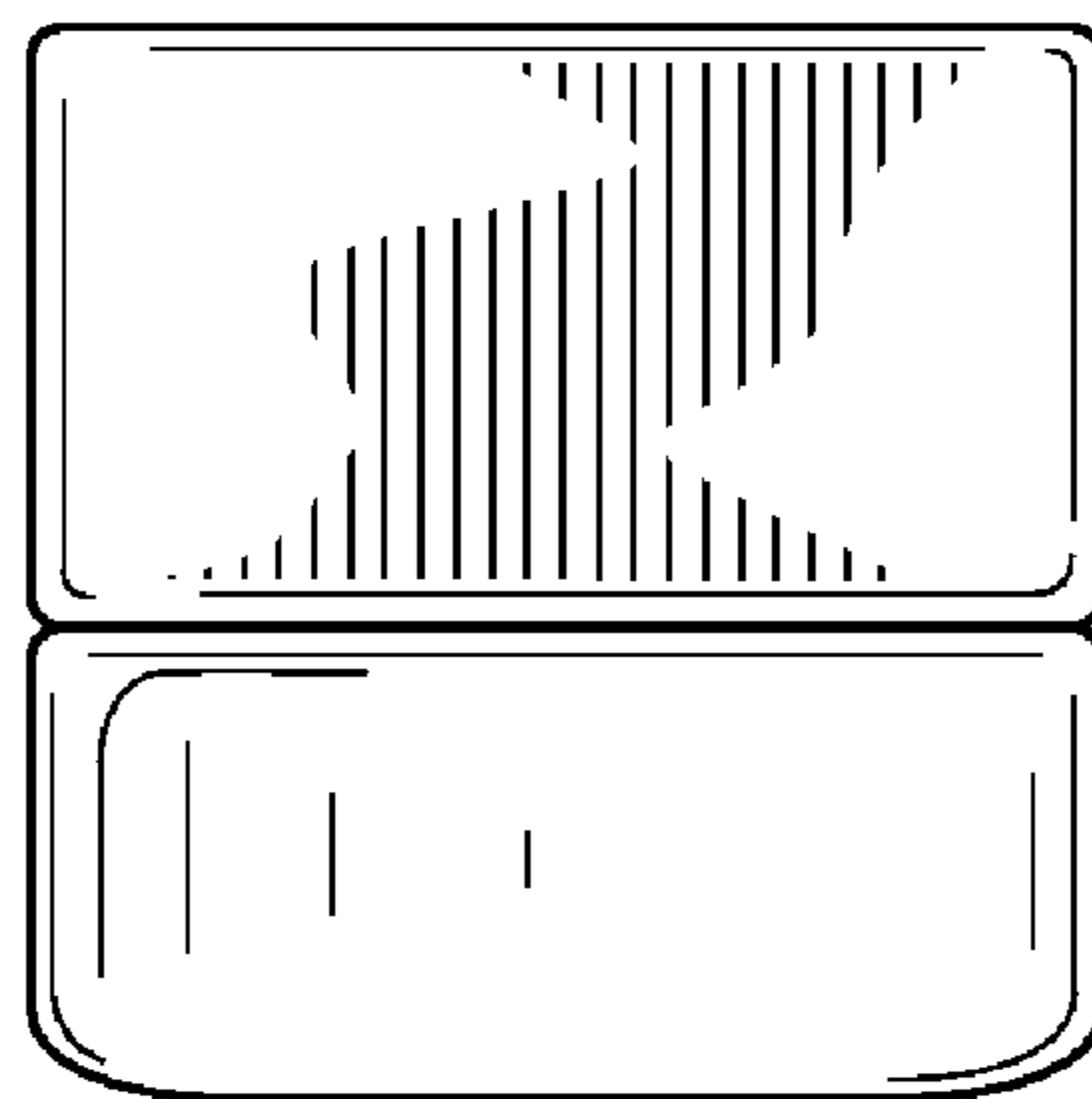

FIG. 5

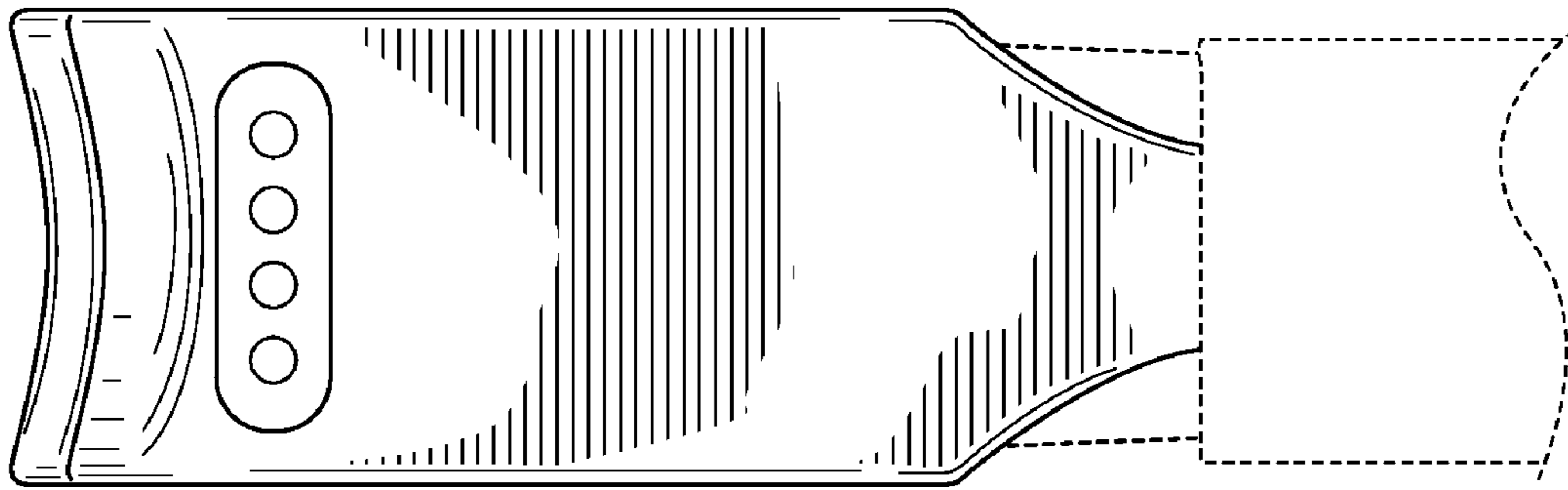

FIG. 6

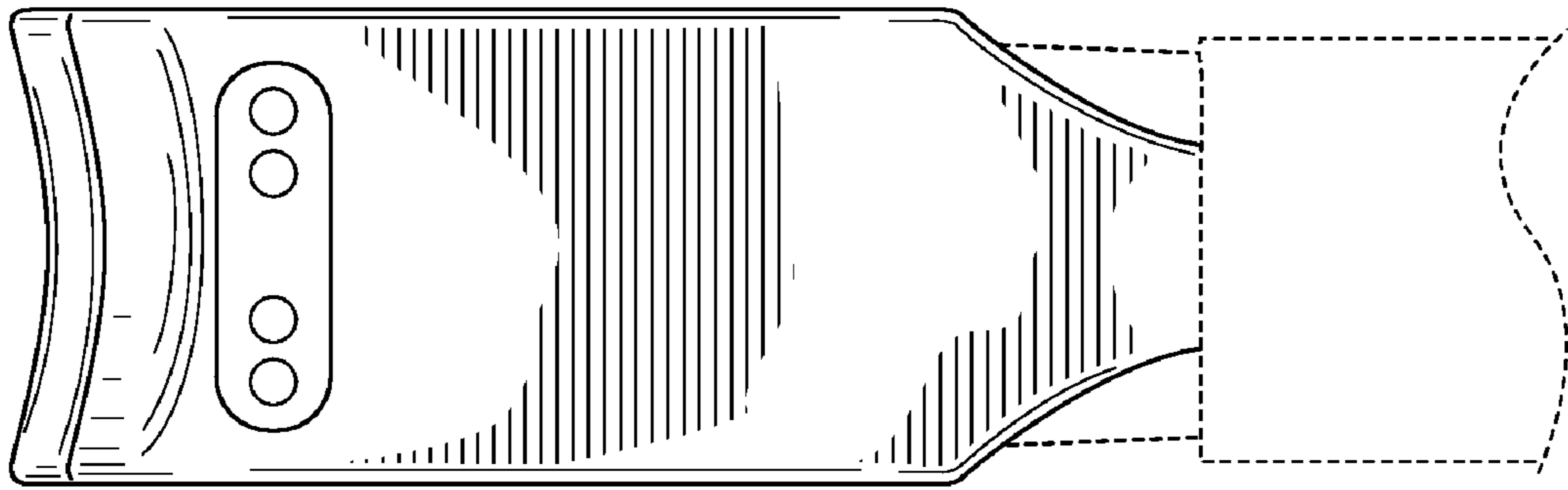

FIG. 7

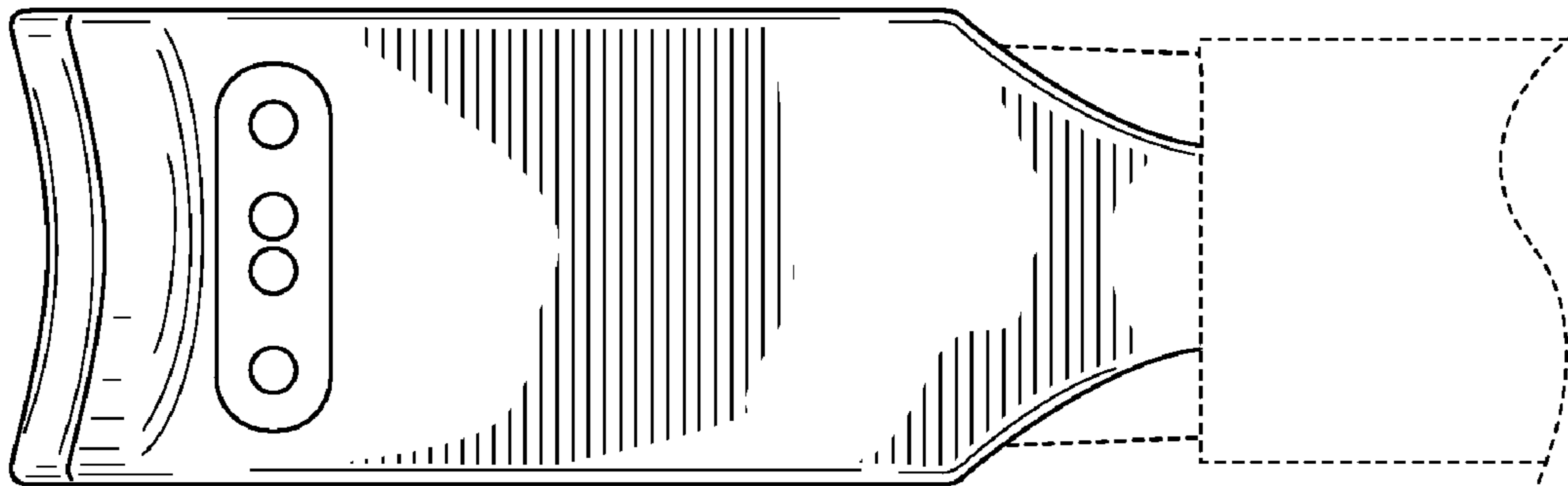

FIG. 8

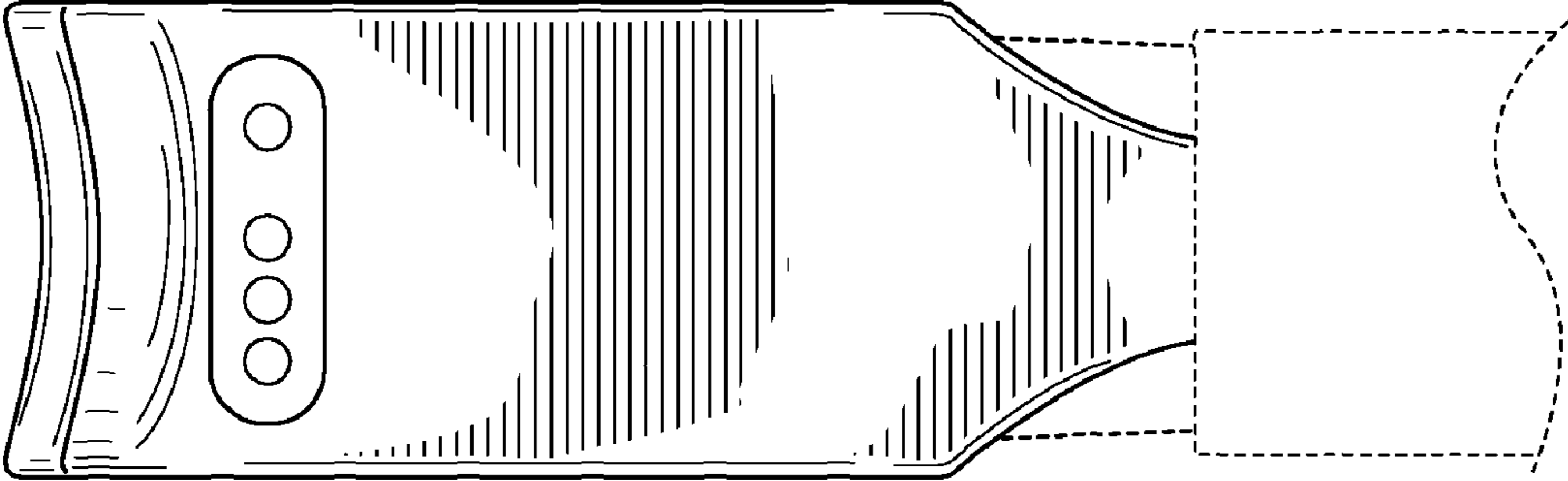

FIG. 9

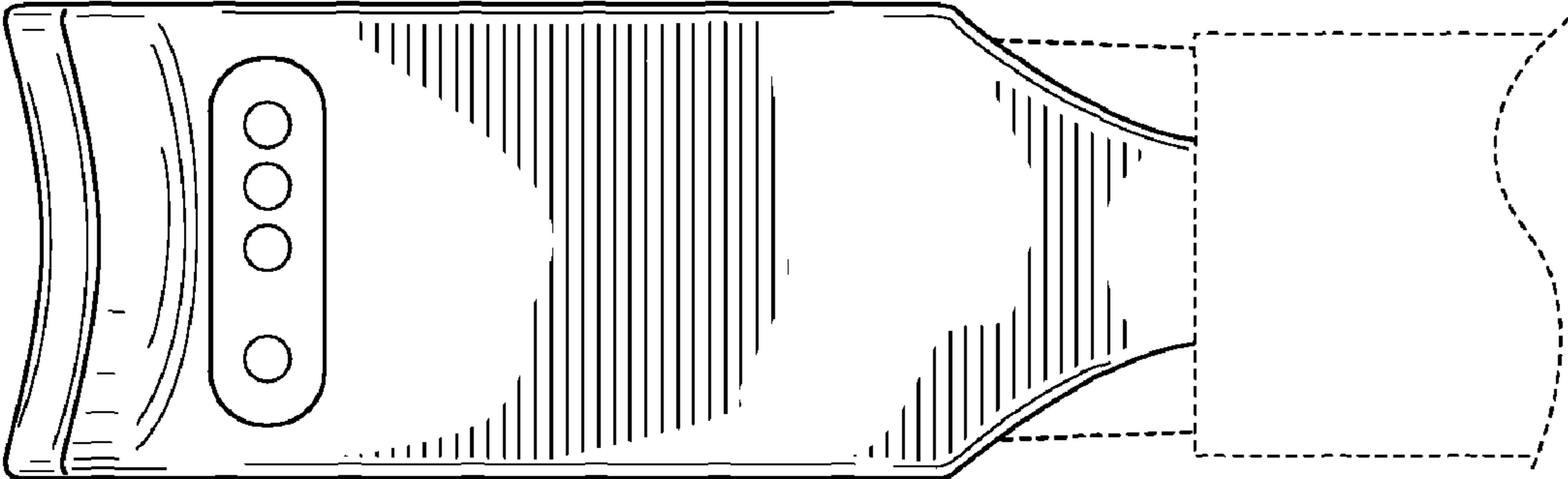

FIG. 10

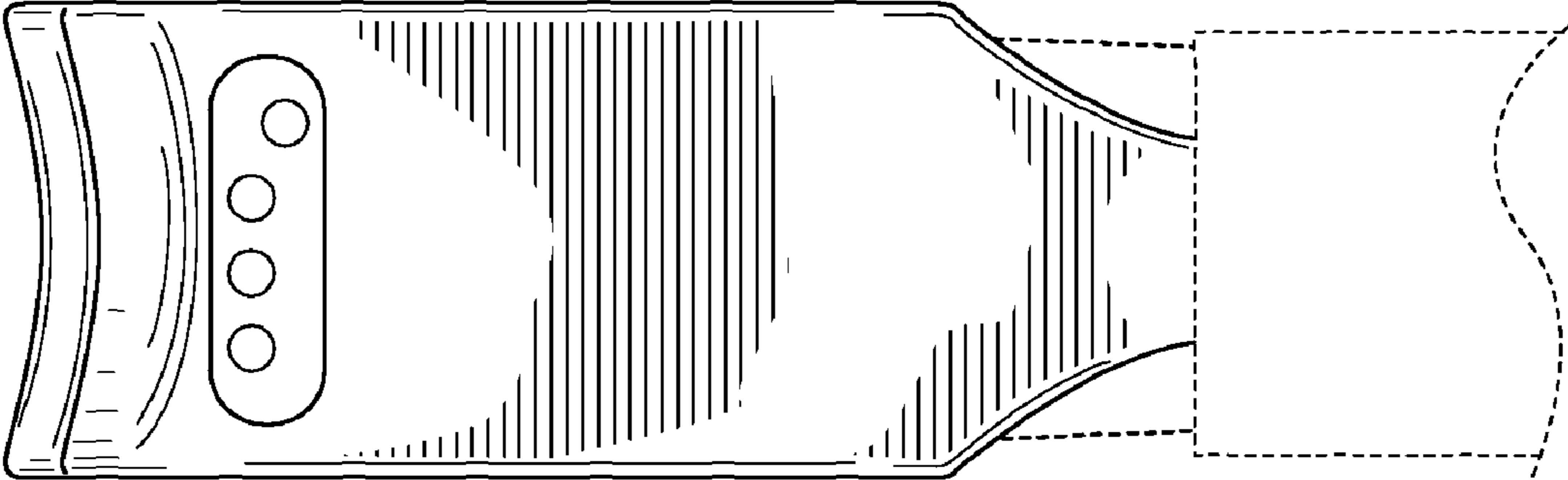

FIG. 11

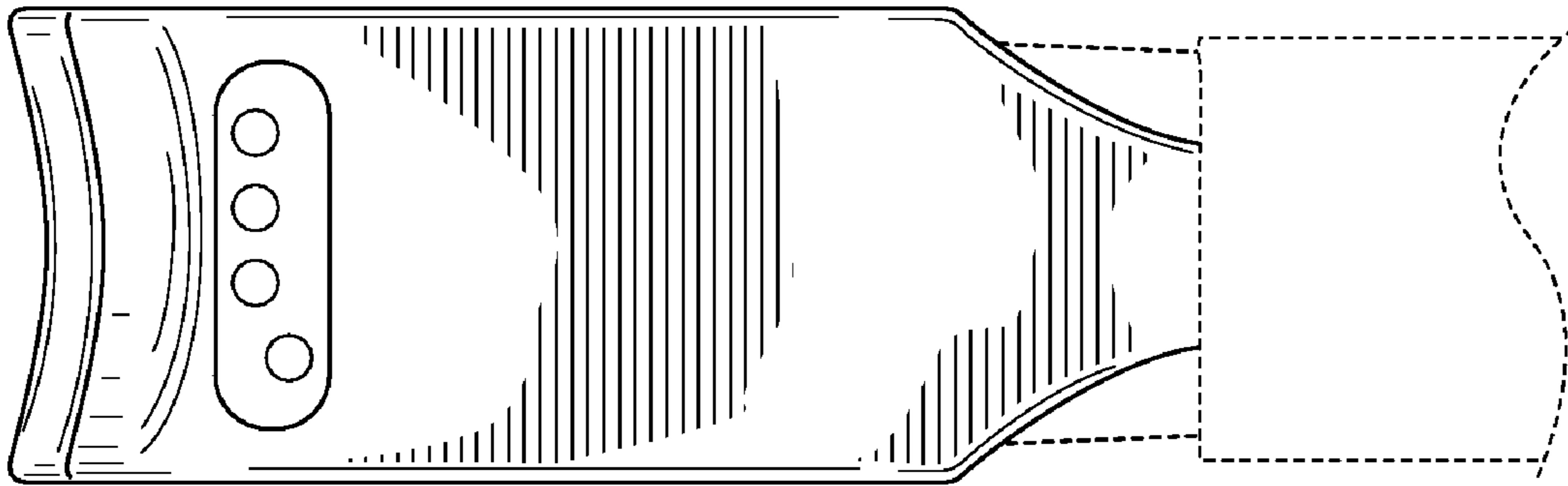

FIG. 12

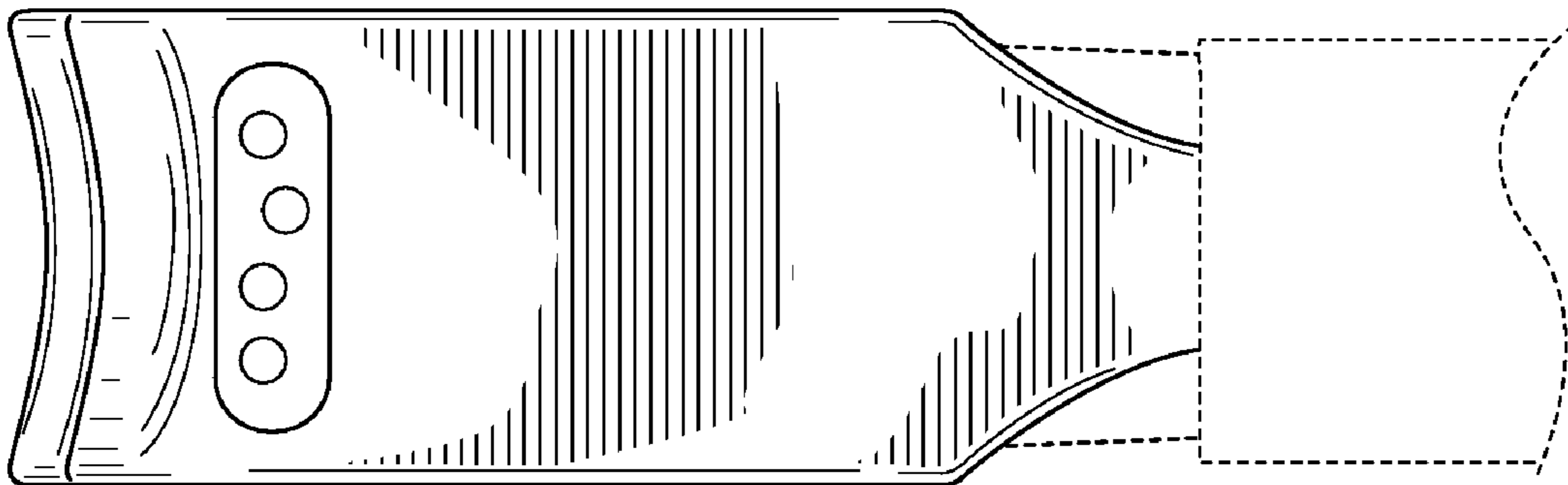

FIG. 13

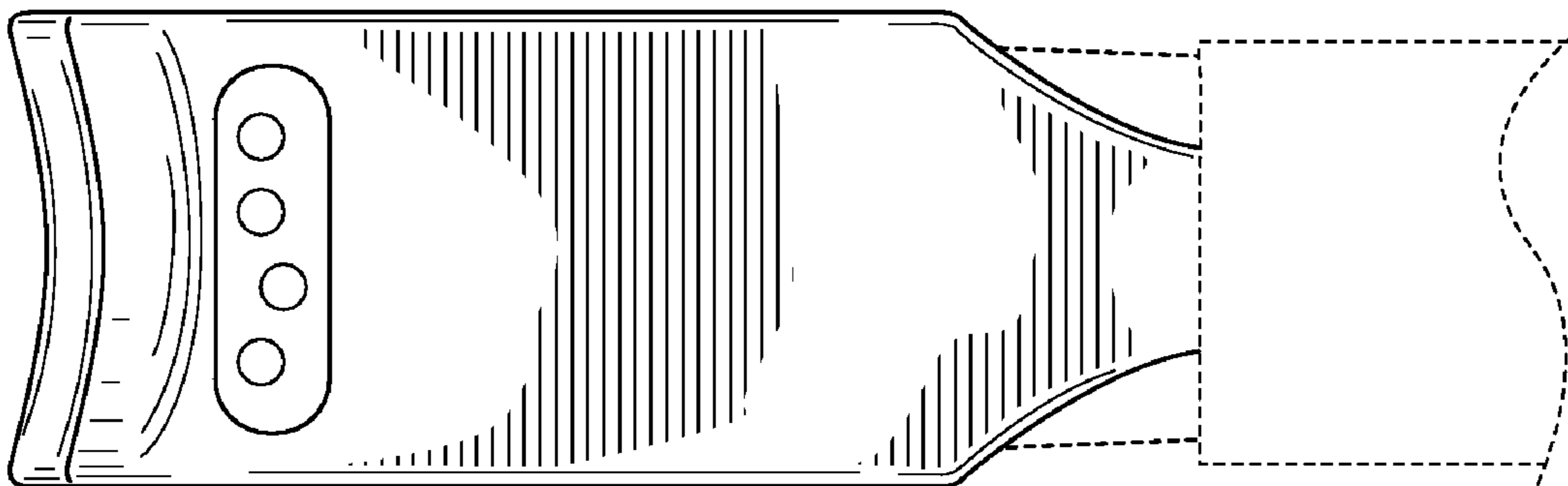

FIG. 14

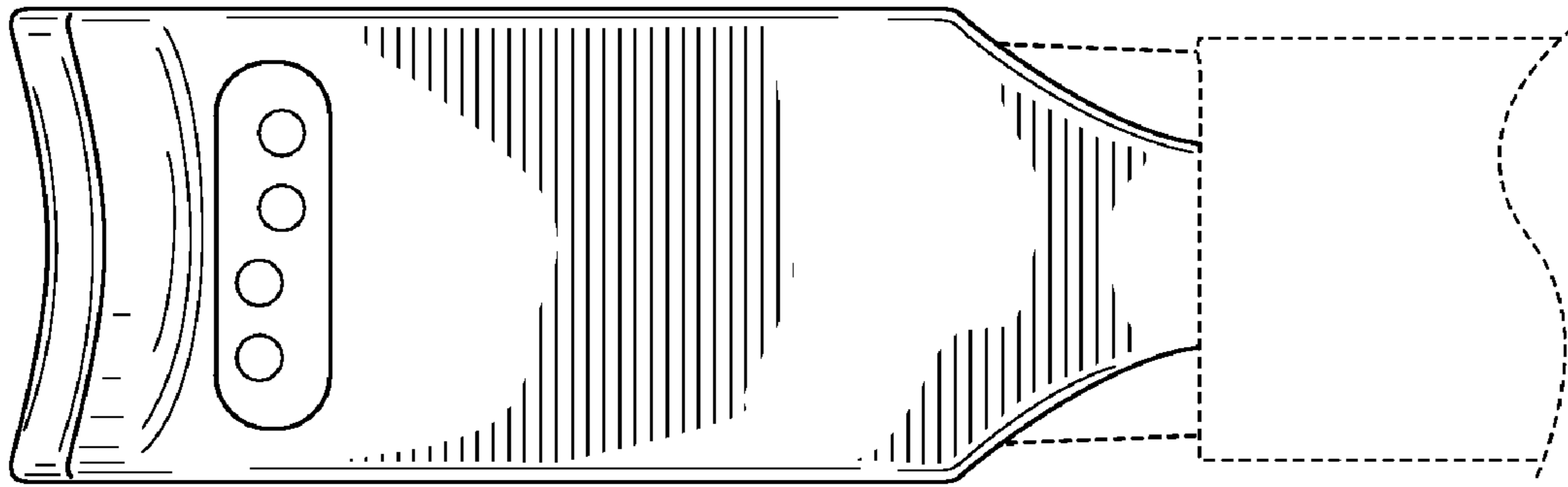

FIG. 15

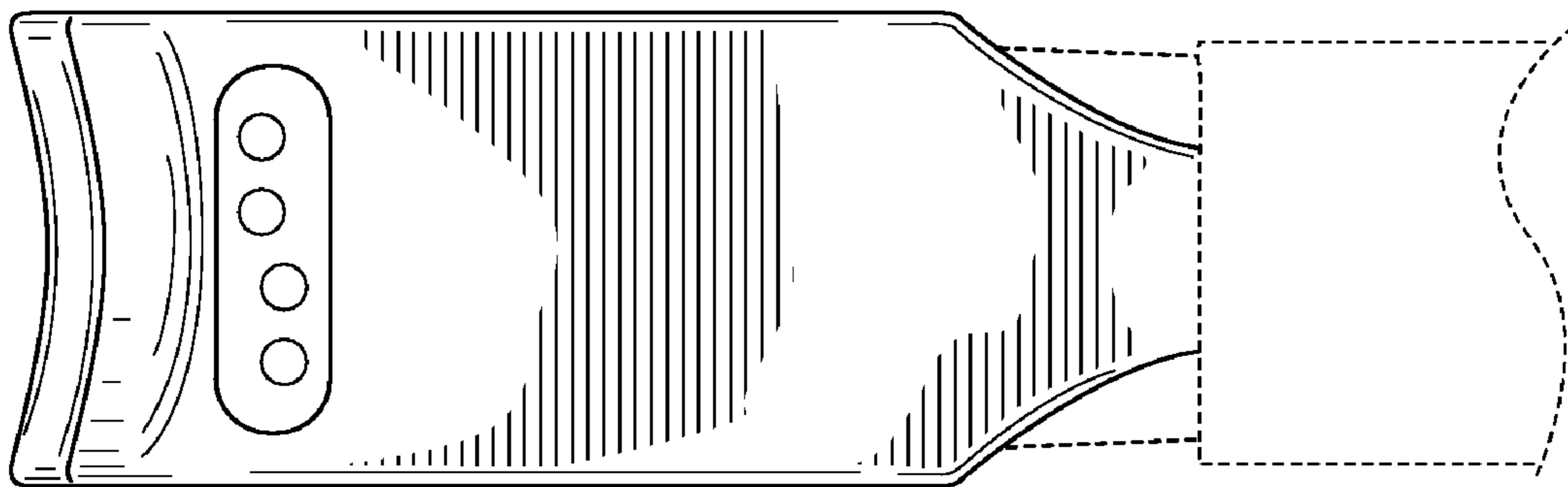

FIG. 16

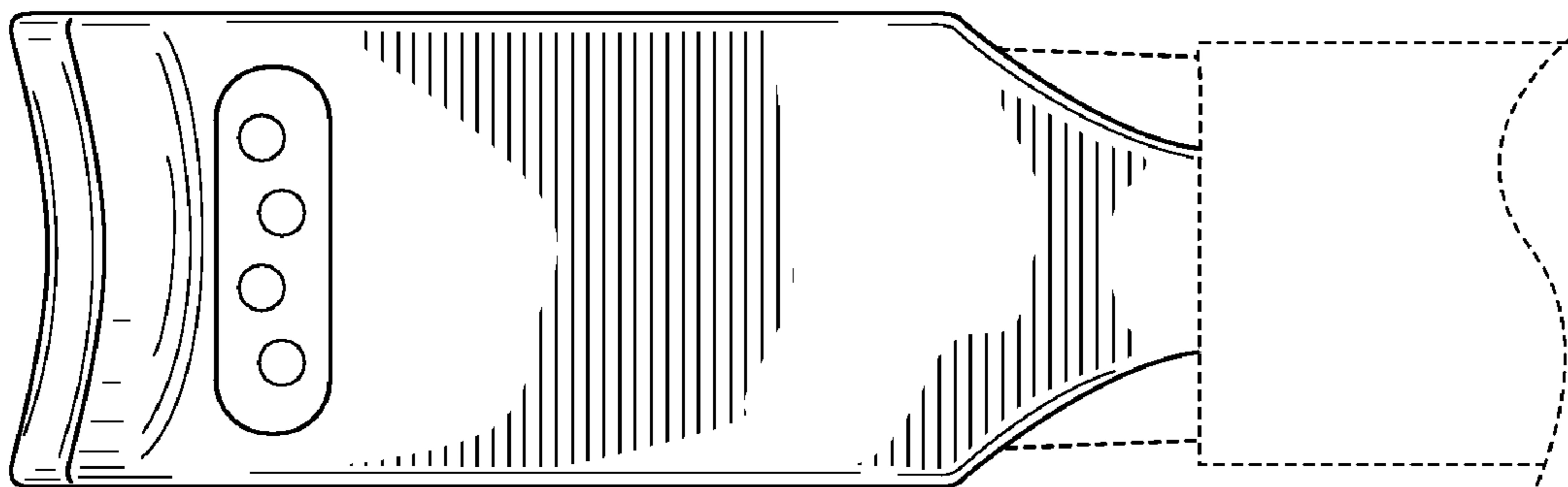

FIG. 17

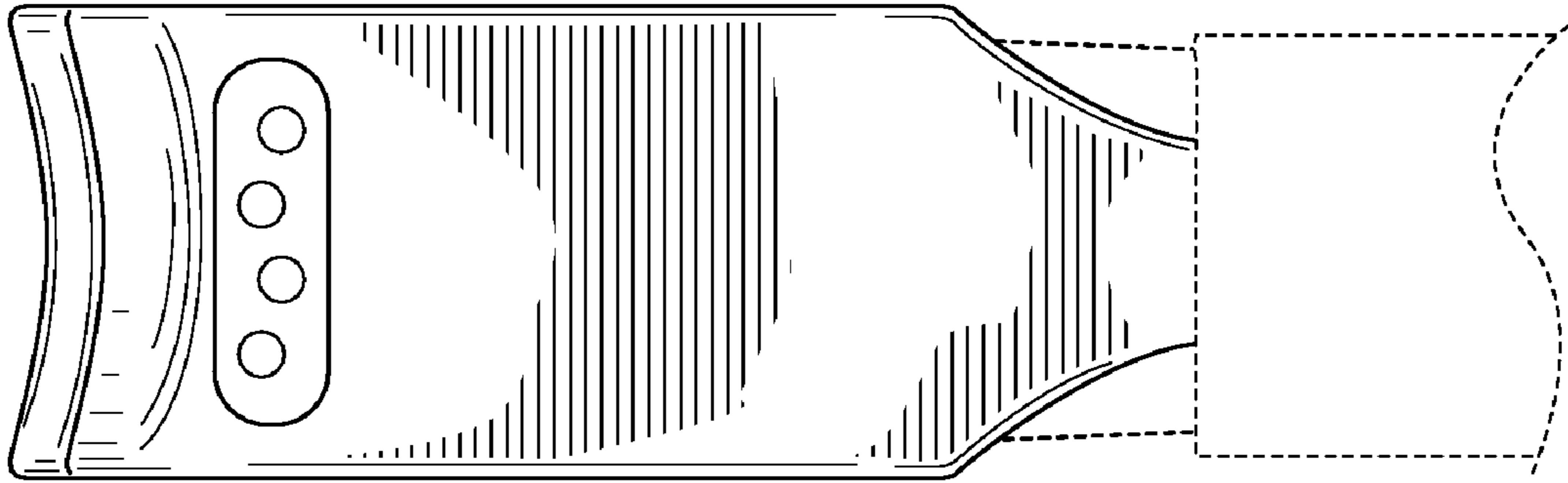

FIG. 18

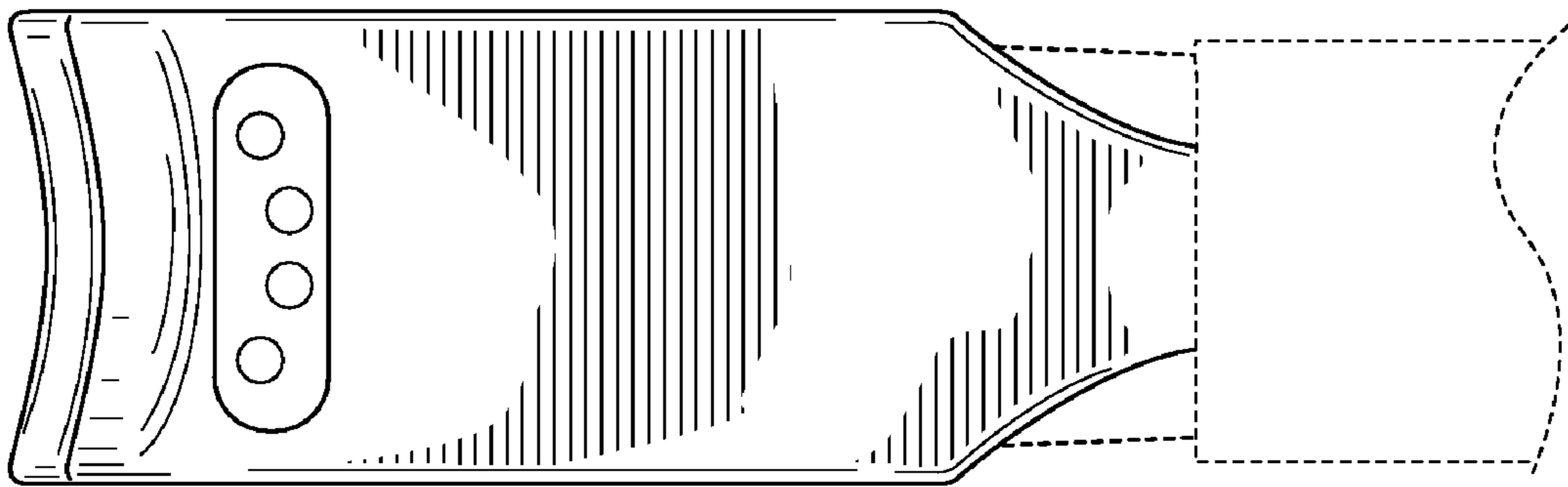

FIG. 19

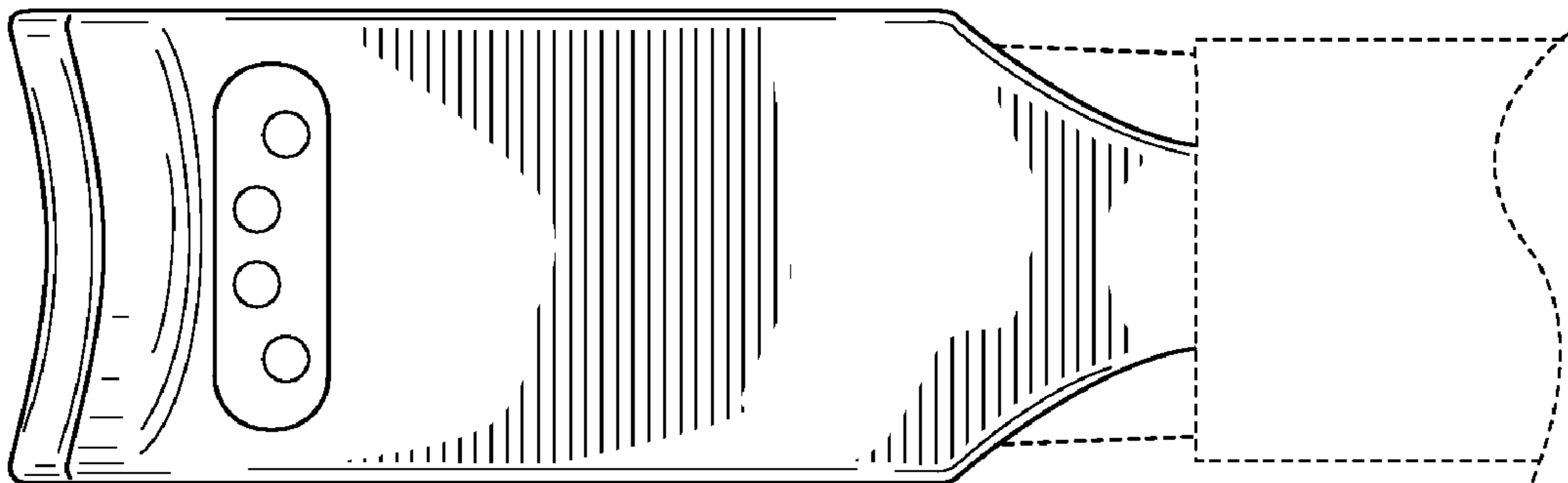

FIG. 20

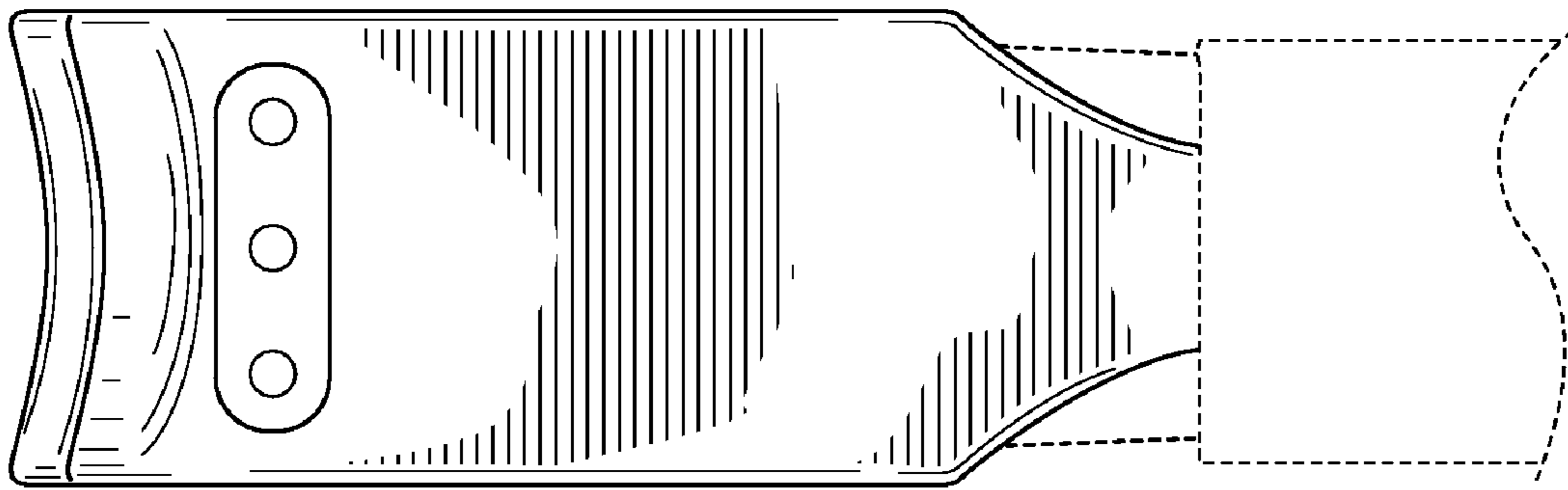

FIG. 21

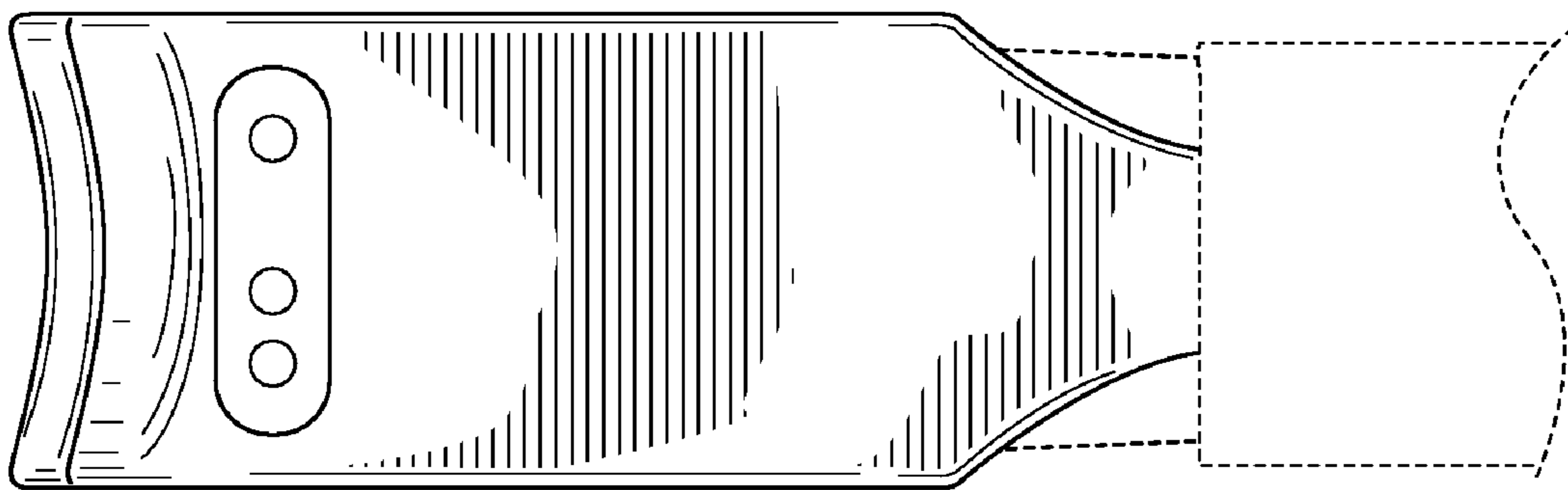

FIG. 22

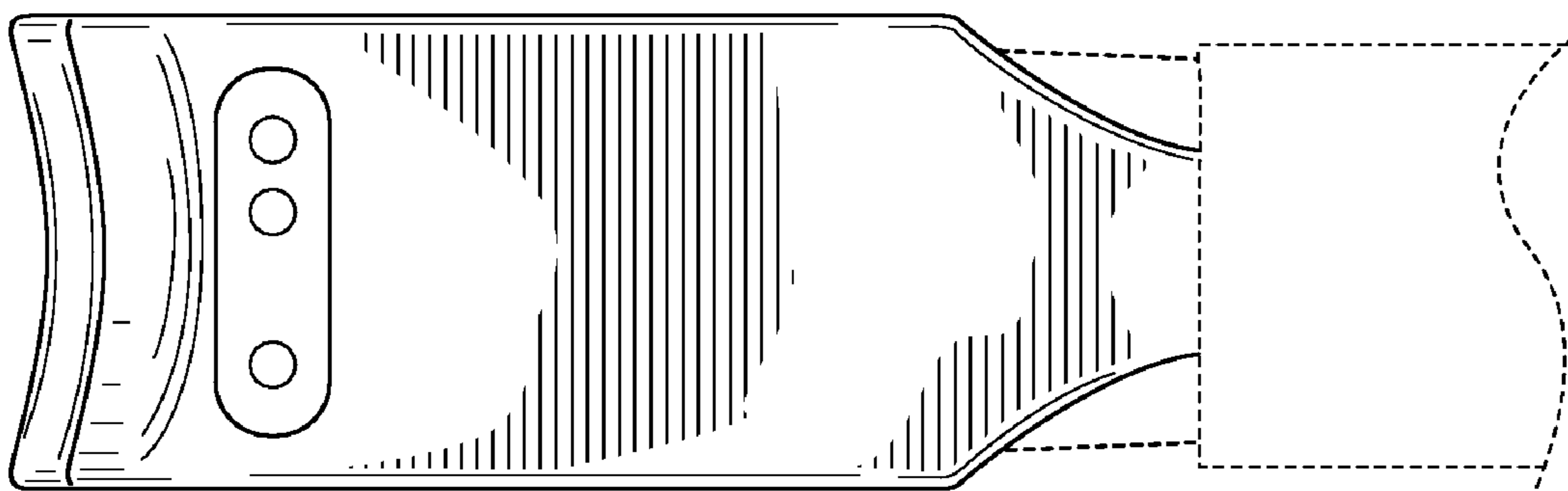

FIG. 23

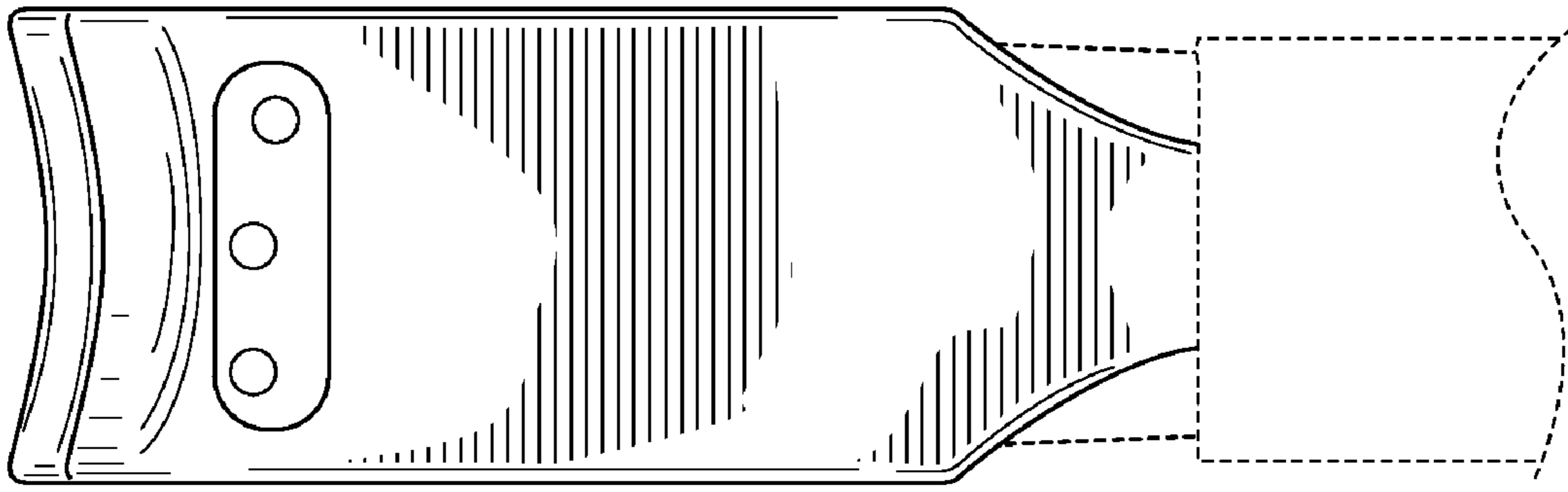

FIG. 24

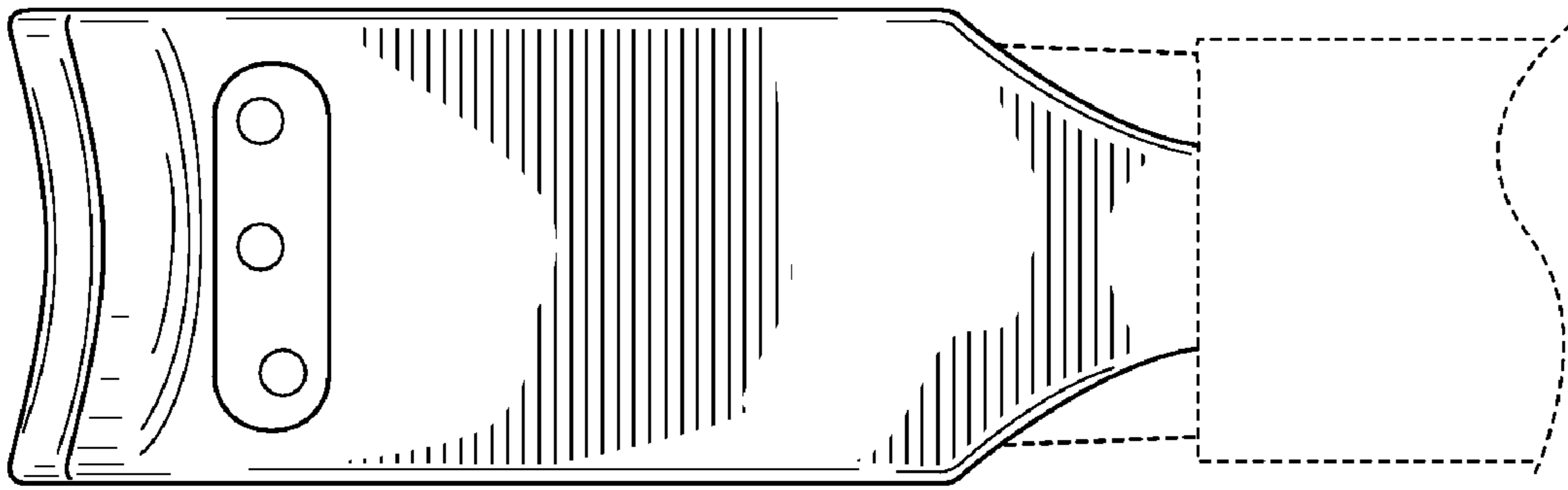

FIG. 25

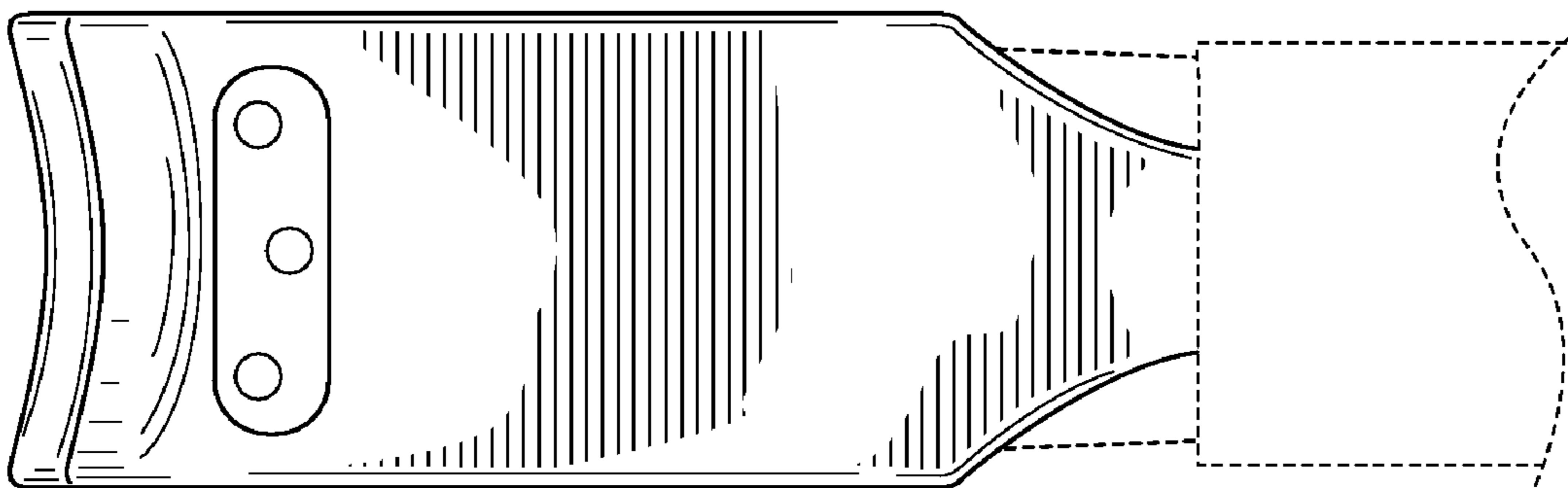

FIG. 26

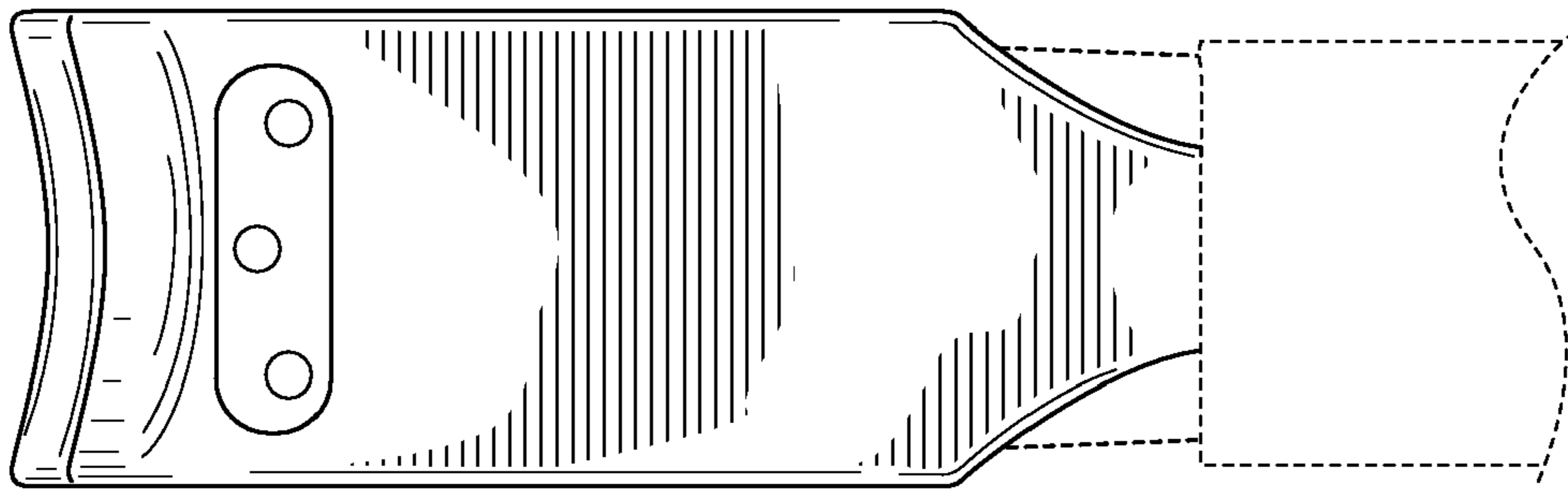

FIG. 27

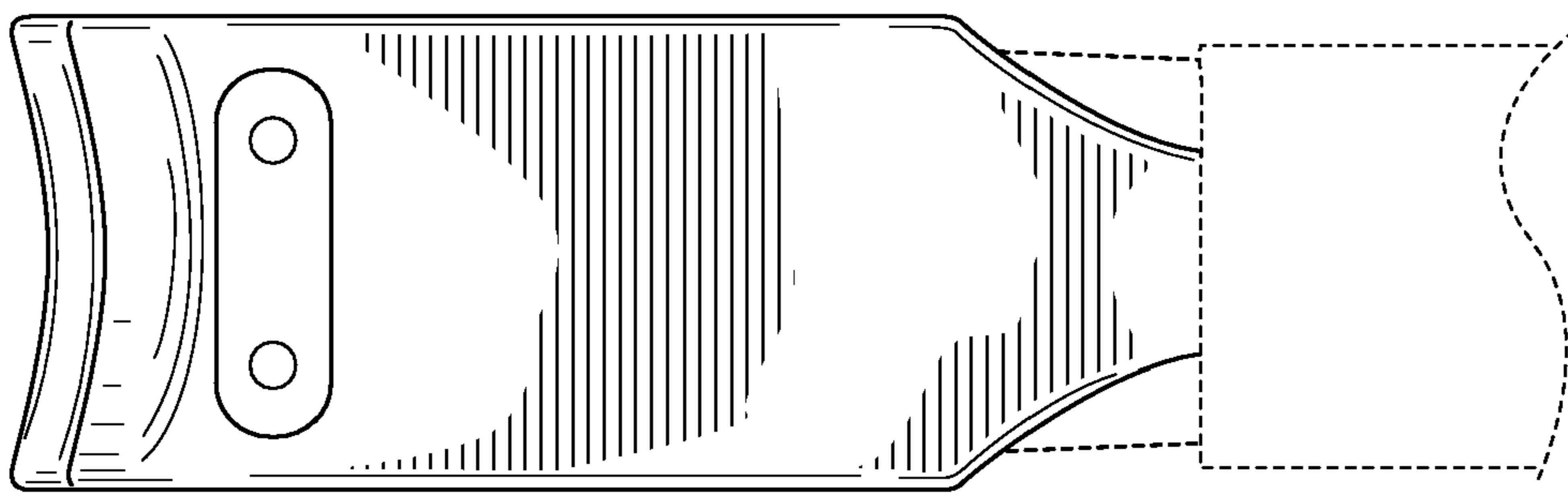

FIG. 28

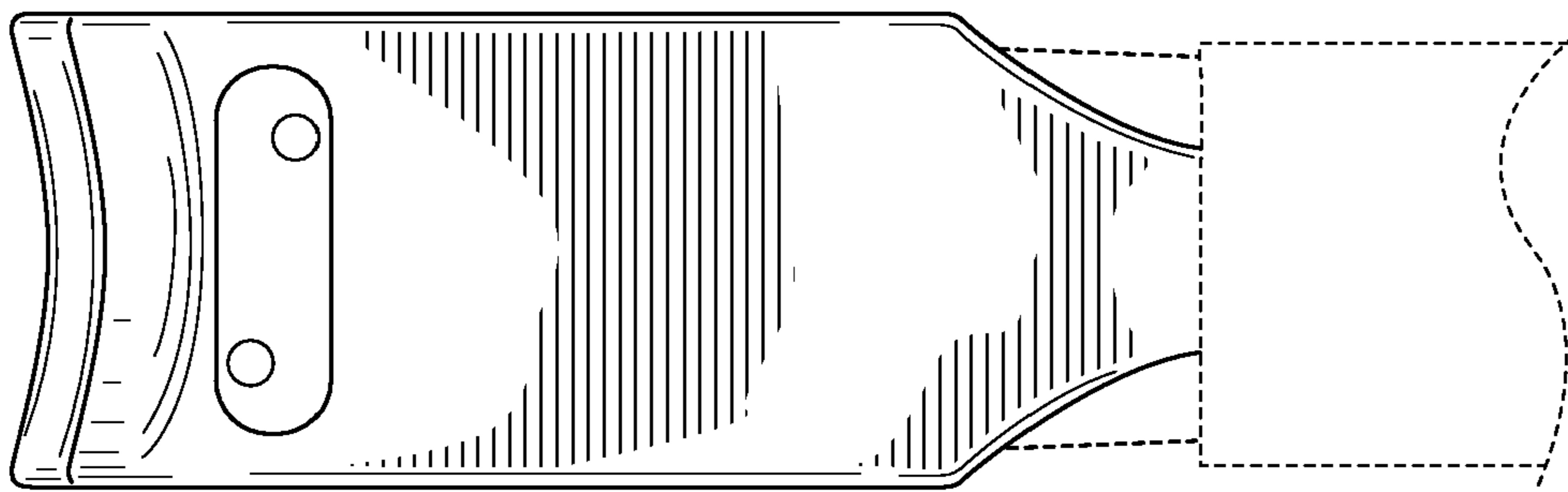

FIG. 29

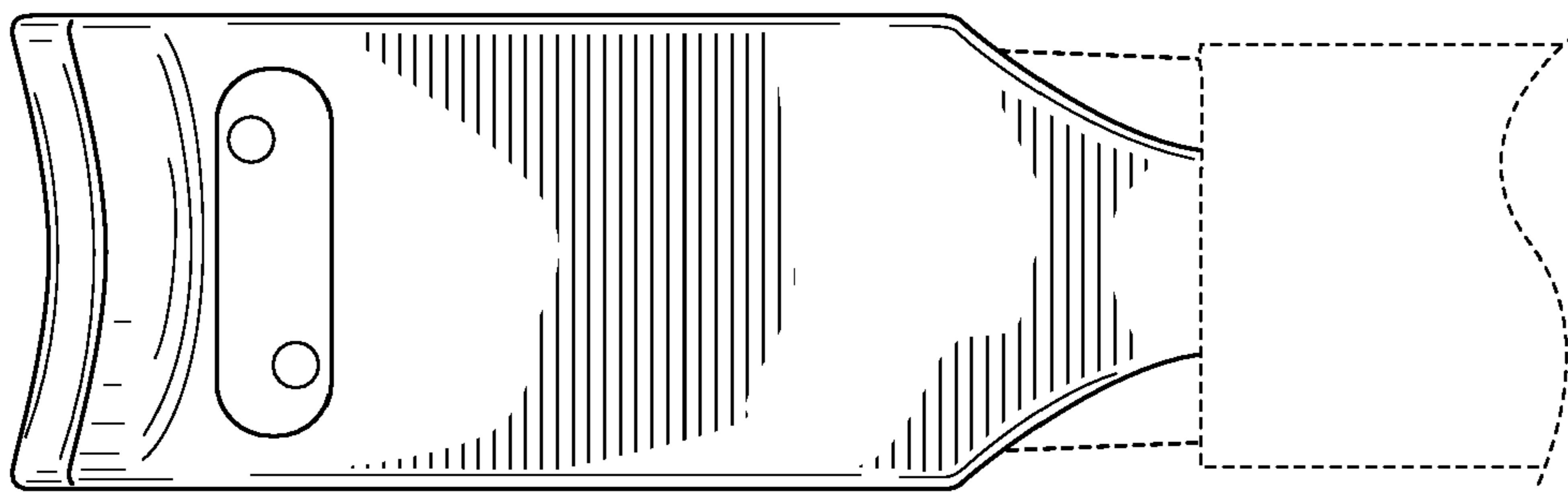

FIG. 30