



US00D620395S

(12) **United States Design Patent**  
**Abdallah**

(10) **Patent No.:** **US D620,395 S**  
(45) **Date of Patent:** **\*\* Jul. 27, 2010**

(54) **AUTOMOBILE**

(76) Inventor: **Bassam Abdallah**, 27, rue Robert de Flers, Paris (FR) 75015

(\*\*) Term: **14 Years**

(21) Appl. No.: **29/330,631**

(22) Filed: **Jan. 12, 2009**

(51) **LOC (9) Cl.** ..... **12-08**

(52) **U.S. Cl.** ..... **D12/92**

(58) **Field of Classification Search** ..... D12/86,  
D12/90-92; D21/424, 433, 434; 296/181.1,  
296/181.5

See application file for complete search history.

(56) **References Cited**

**U.S. PATENT DOCUMENTS**

D203,667 S *	2/1966	Loewy	.....	D12/92
D283,882 S *	5/1986	Giugiaro	.....	D12/91
D307,248 S *	4/1990	Dettling	.....	D12/91
D502,133 S *	2/2005	Ferrari	.....	D12/196
D510,551 S *	10/2005	Mays et al.	.....	D12/173
D566,027 S *	4/2008	Gavriles	.....	D12/196

**OTHER PUBLICATIONS**

1966 Shelby GT350H and 2007 Shelby GT-H, Motor Trend Magazine, Sep. 2006, p. 36.\*

The 2007 Boss 302 Mustang, Motor Trend Magazine, Mar. 2007 pp. 122-125.\*

\* cited by examiner

*Primary Examiner*—Melody N Brown

(74) *Attorney, Agent, or Firm*—Quinn Law Group, PLLC

(57) **CLAIM**

The ornamental design for an automobile, as shown and described.

**DESCRIPTION**

FIG. 1 is a perspective view of an automobile in accordance with my design as view from the front right;

FIG. 2 is a perspective view of my design as view from the left rear;

FIG. 3 is a front elevational view thereof;

FIG. 4 is a right side view thereof, with the left side view being a substantial mirror image of the right side view; and,

FIG. 5 is a rear elevational view.

The broken lines shown throughout the drawing are for illustrative purposes only and form no part of the claimed design.

**1 Claim, 5 Drawing Sheets**

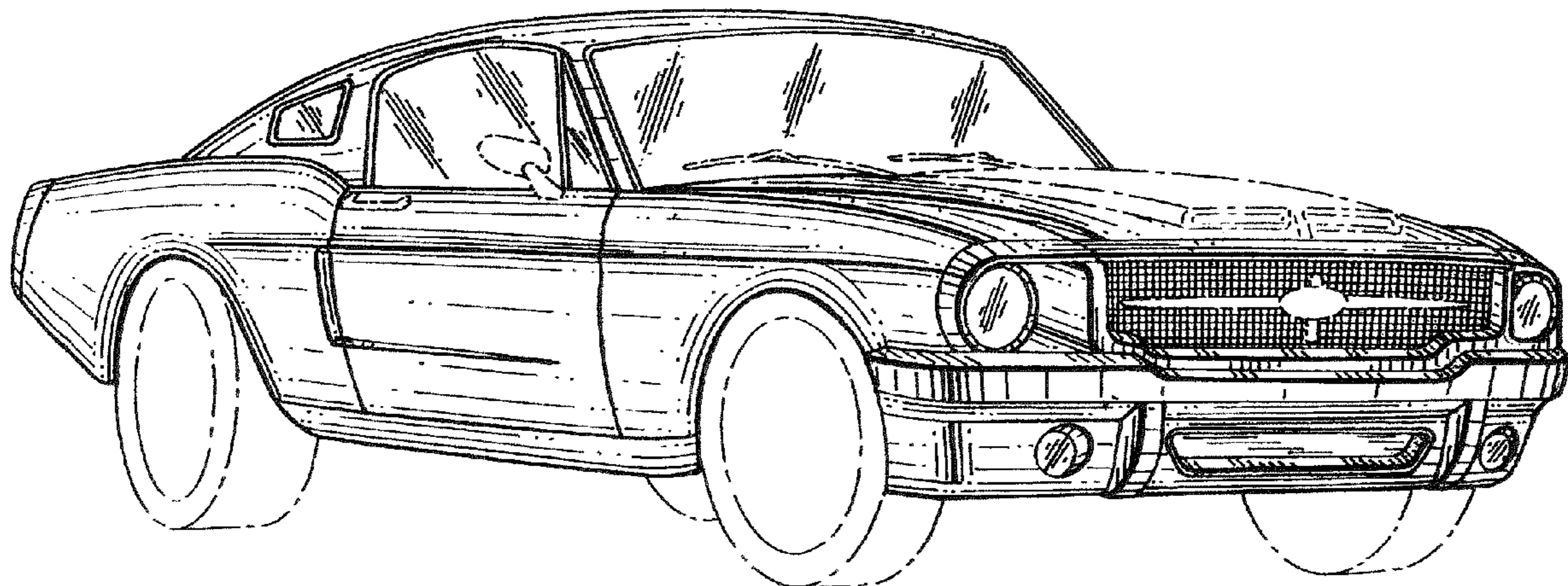

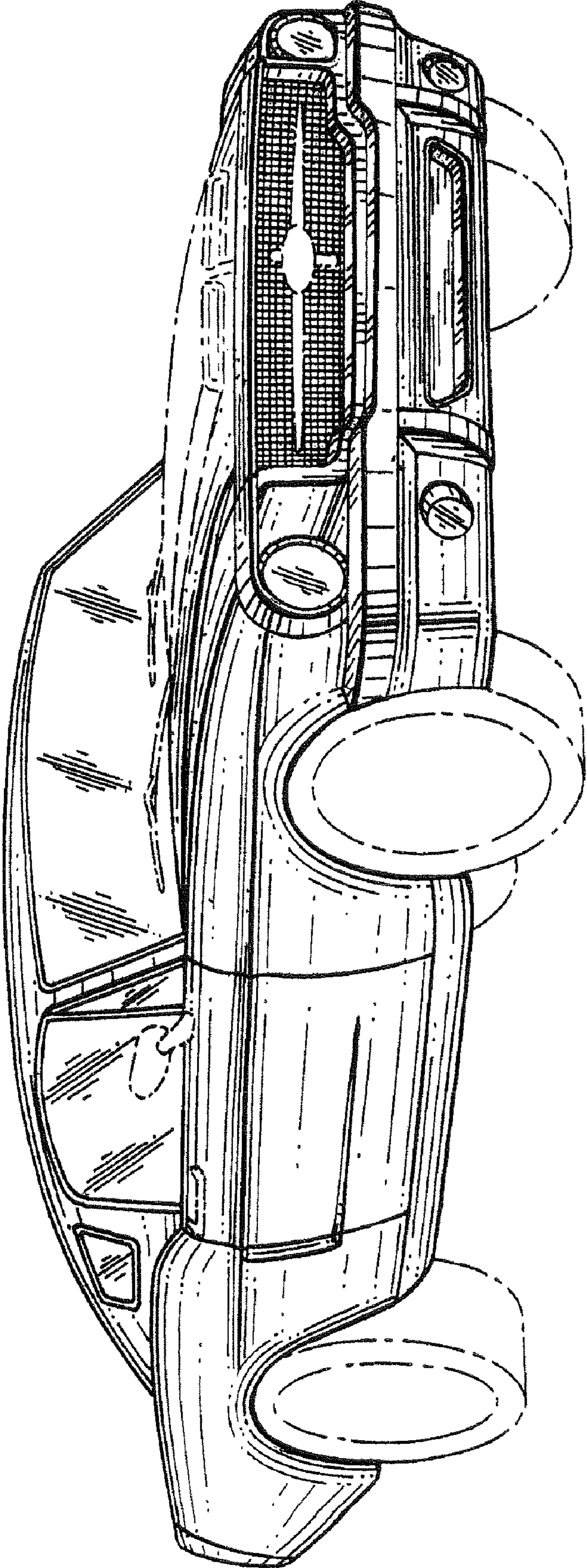

FIG.1

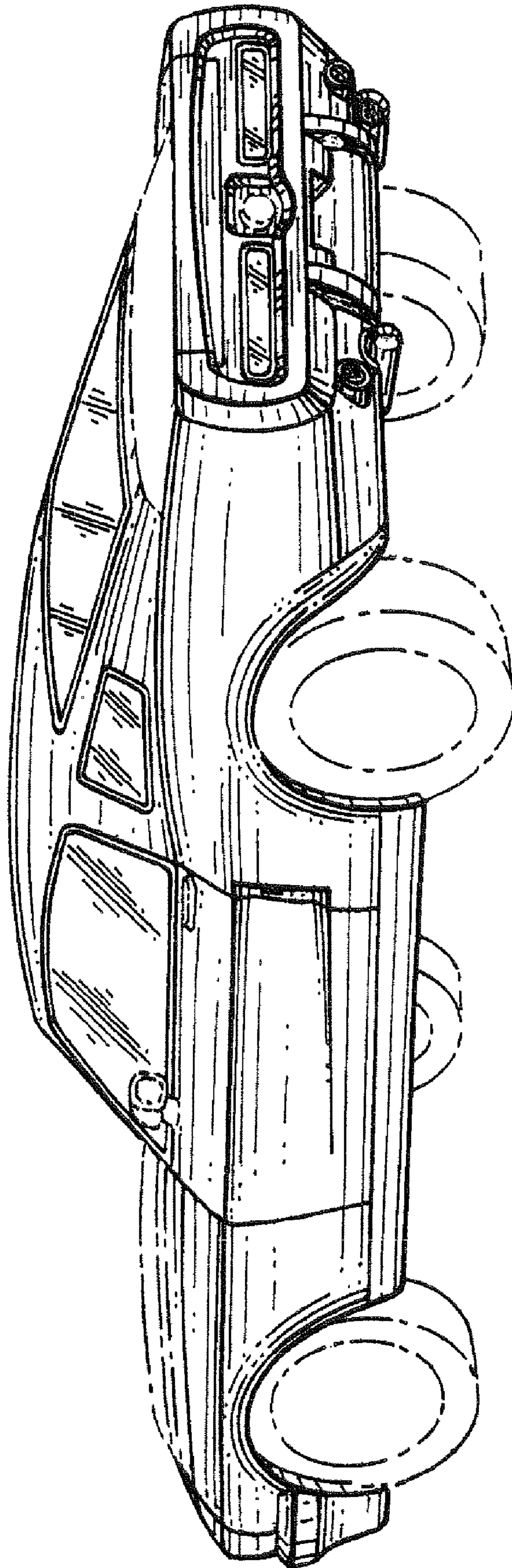

FIG.2

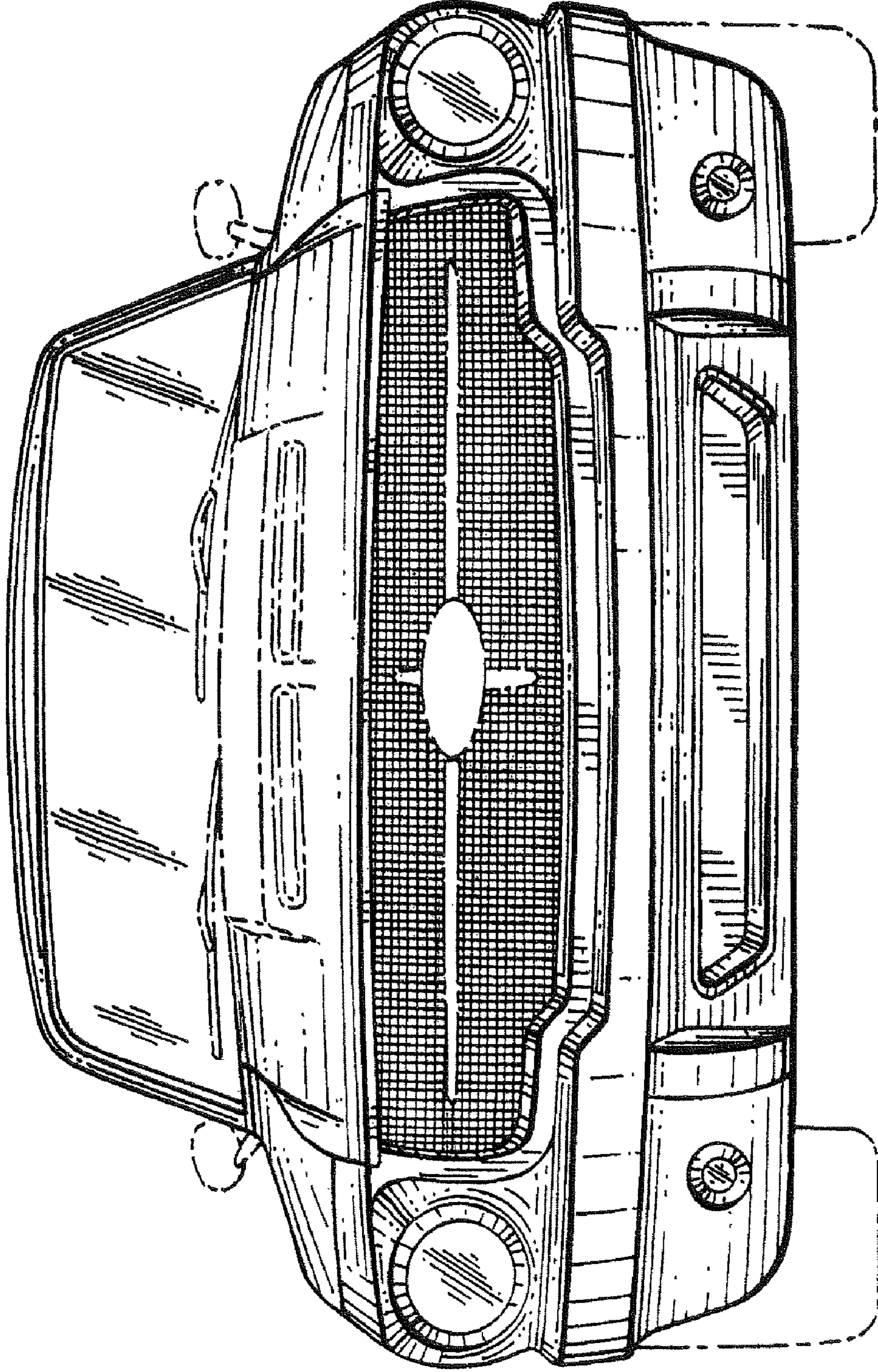

FIG.3

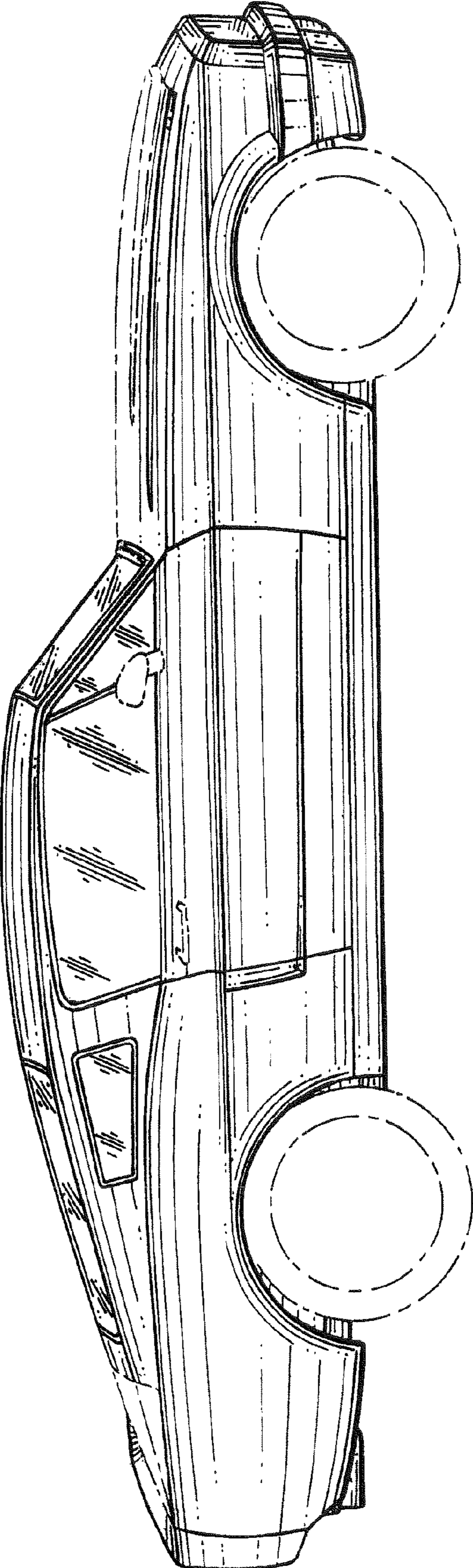

FIG.4

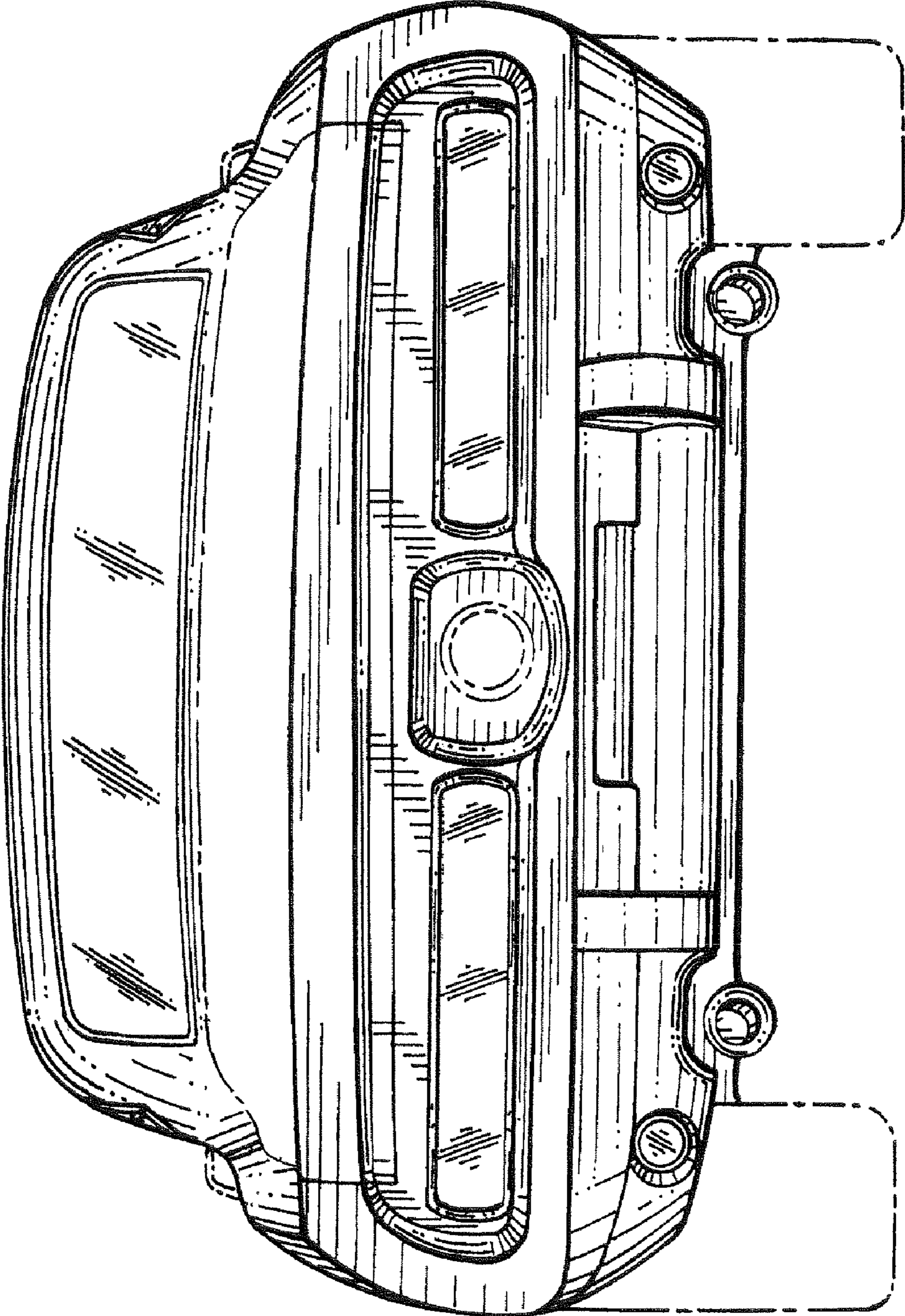

FIG. 5