



US00D620324S

(12) **United States Design Patent**
Griffith

(10) **Patent No.:** **US D620,324 S**
(45) **Date of Patent:** **** Jul. 27, 2010**

- (54) **GARLIC PRESS**
- (75) Inventor: **Jonah S. Griffith**, Seattle, WA (US)
- (73) Assignee: **Chef'n Corporation**, Seattle, WA (US)
- (**) Term: **14 Years**
- (21) Appl. No.: **29/353,062**
- (22) Filed: **Dec. 31, 2009**

| | | | |
|-------------------|---------|-------------------------|---------------|
| D304,900 S | 12/1989 | Miquelot | |
| 5,022,159 A | 6/1991 | Cressman et al. | |
| D322,919 S | 1/1992 | Holcomb et al. | |
| 5,291,658 A | 3/1994 | Wilson et al. | |
| 5,581,897 A | 12/1996 | Liebscher | |
| 6,374,502 B1 | 4/2002 | Holcomb et al. | |
| D499,941 S * | 12/2004 | Levien et al. | D7/666 |
| 7,000,535 B2 * | 2/2006 | Harrison-Griffin et al. | .. 100/126 |
| D521,818 S * | 5/2006 | So | D7/665 |
| 7,299,747 B2 * | 11/2007 | So | 100/234 |
| 2006/0086265 A1 * | 4/2006 | Gonzalez | 100/234 |

Related U.S. Application Data

- (62) Division of application No. 29/334,066, filed on Mar. 19, 2009, now Pat. No. Des. 608,604.
- (51) **LOC (9) Cl.** **07-04**
- (52) **U.S. Cl.** **D7/666**
- (58) **Field of Classification Search** D7/665-668, D7/680; 99/495, 506-511; 100/99, 104, 100/110, 112, 116, 125, 126, 233, 234, 243, 100/213; 241/95, 169.1, 169.2, 273.3
See application file for complete search history.

* cited by examiner

Primary Examiner—Terry A Wallace

(74) *Attorney, Agent, or Firm*—Seed IP Law Group PLLC

(57) **CLAIM**

The ornamental design for a garlic press, as shown and described.

DESCRIPTION

FIG. 1 is a front isometric view of a garlic press showing my new design.

FIG. 2 is a top plan view thereof.

FIG. 3 is a bottom plan view thereof.

FIG. 4 is rear elevation view thereof.

FIG. 5 is a front elevation view thereof.

FIG. 6 is a right side elevation view thereof; and,

FIG. 7 is a left side elevation view thereof.

The broken lines in the figures are for illustrative purposes only and form no part of the claimed design.

(56) **References Cited**

U.S. PATENT DOCUMENTS

| | | |
|-------------|---------|----------------|
| 44,856 A | 11/1864 | Dick |
| 191,416 A | 5/1877 | Fetter |
| 280,495 A | 7/1883 | McWilliams |
| 1,364,016 A | 12/1920 | Worthington |
| 2,718,056 A | 9/1955 | Burnett |
| 4,186,485 A | 2/1980 | Bainton et al. |
| 4,563,818 A | 1/1986 | Kreth et al. |
| D282,521 S | 2/1986 | Steinko |
| 4,754,550 A | 7/1988 | Koo |
| 4,825,554 A | 5/1989 | Koo |

1 Claim, 4 Drawing Sheets

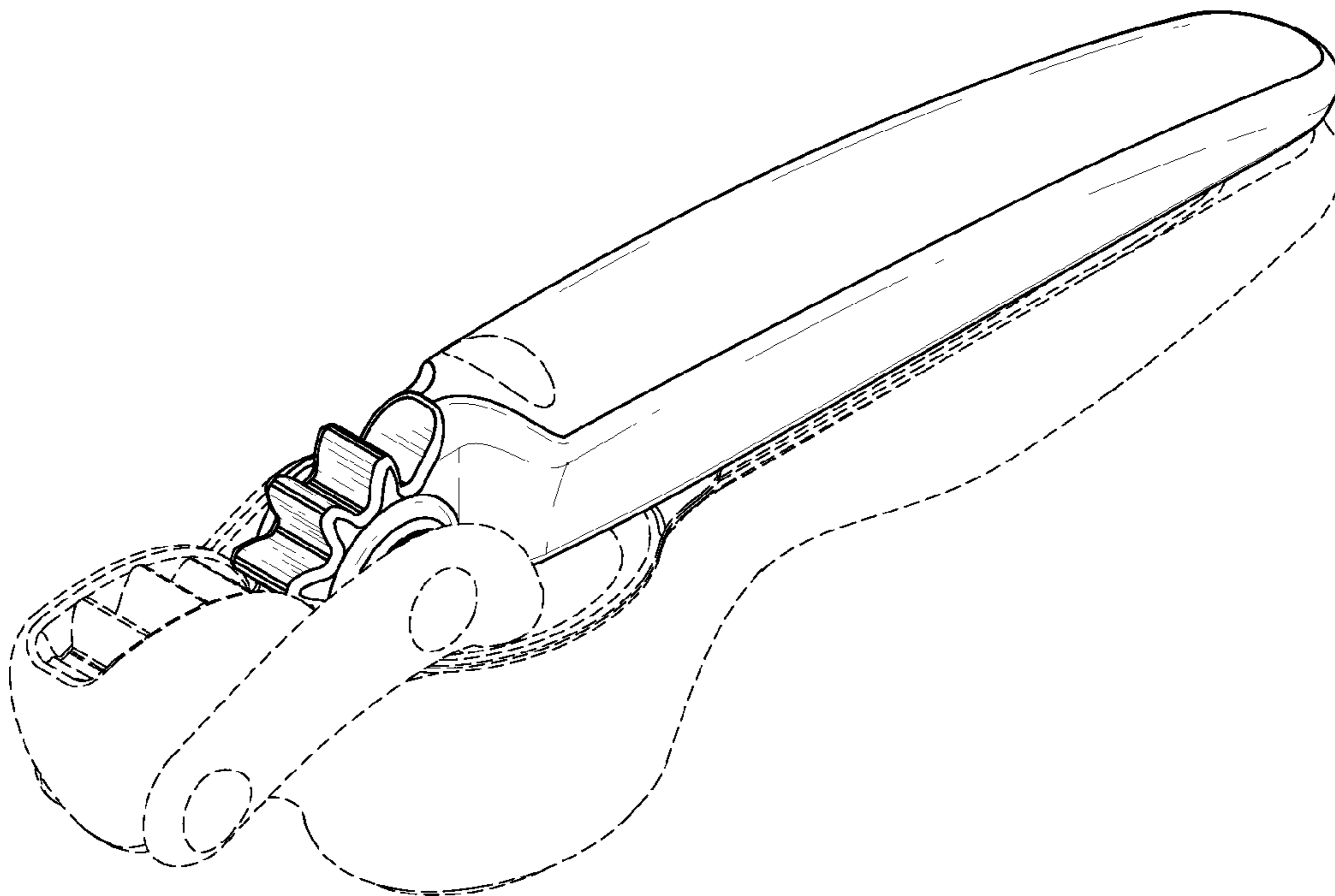

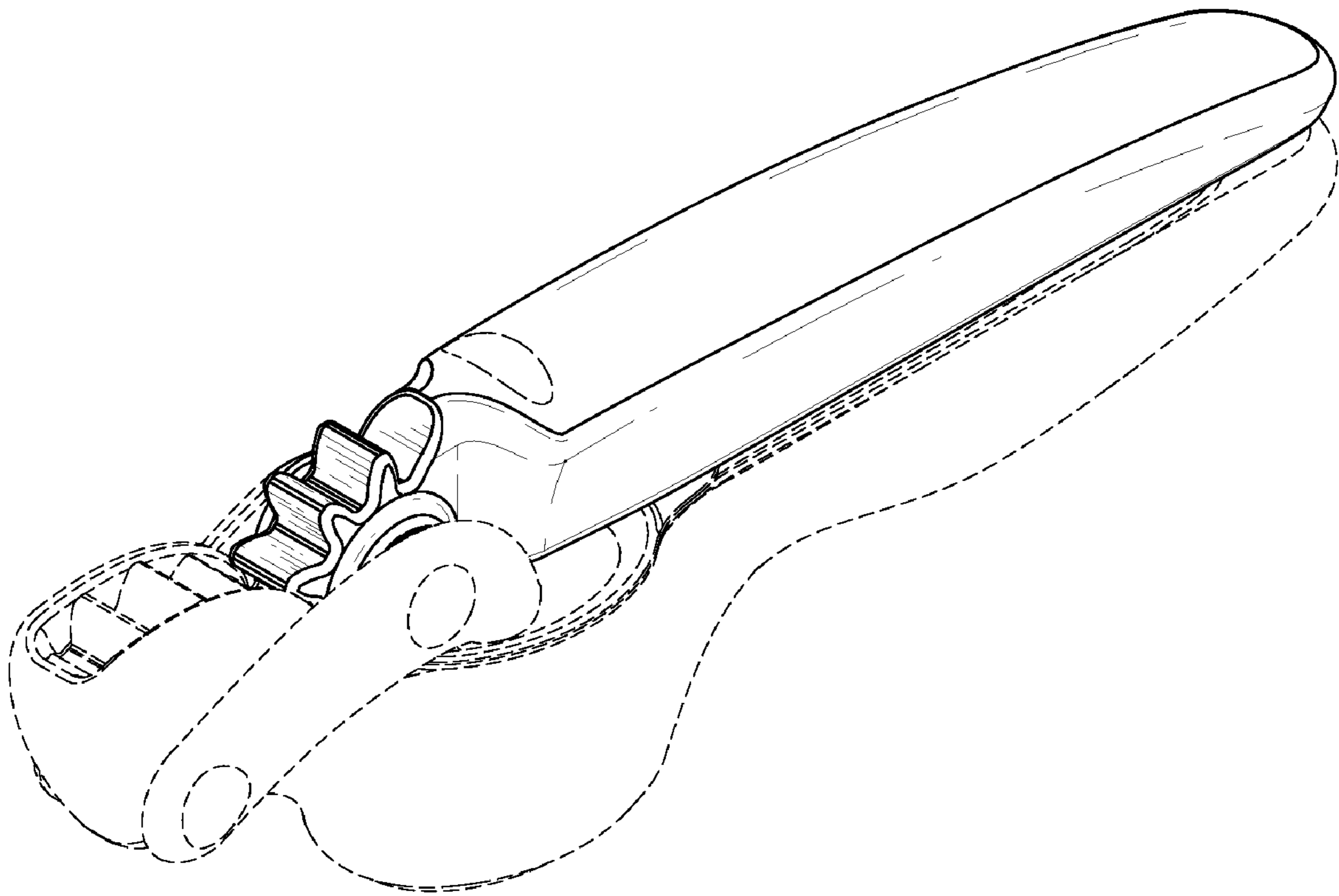

FIG. 1

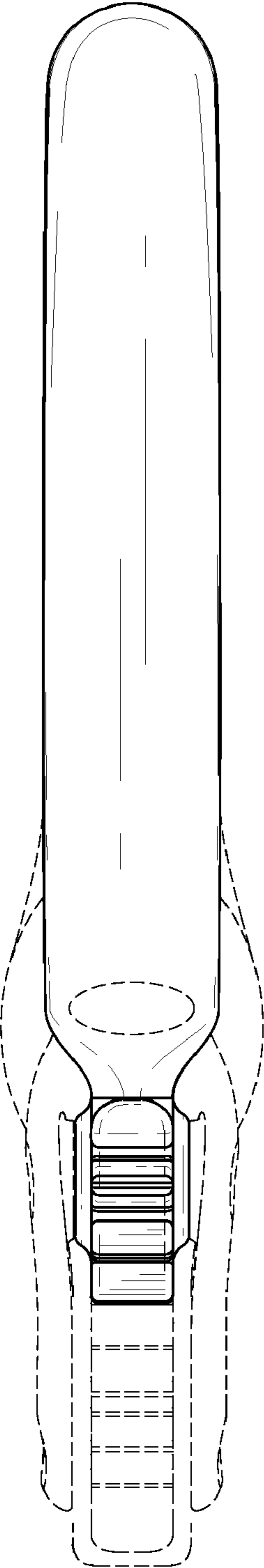

FIG. 2

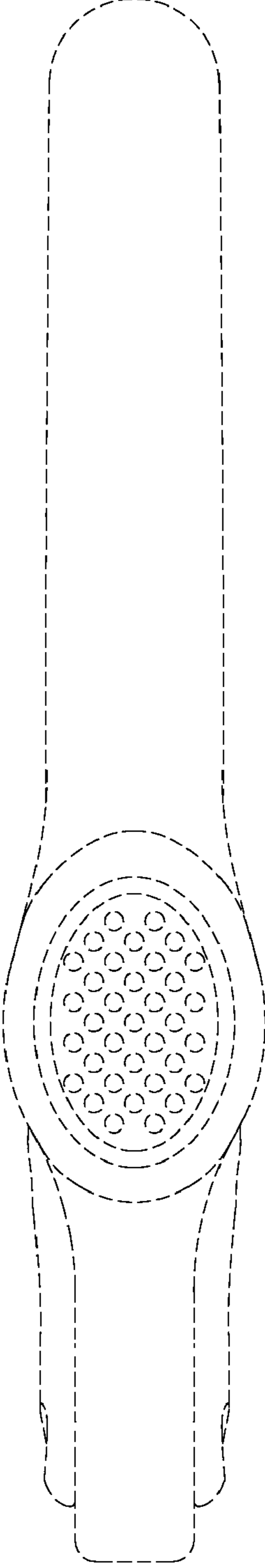

FIG. 3



FIG. 4



FIG. 5

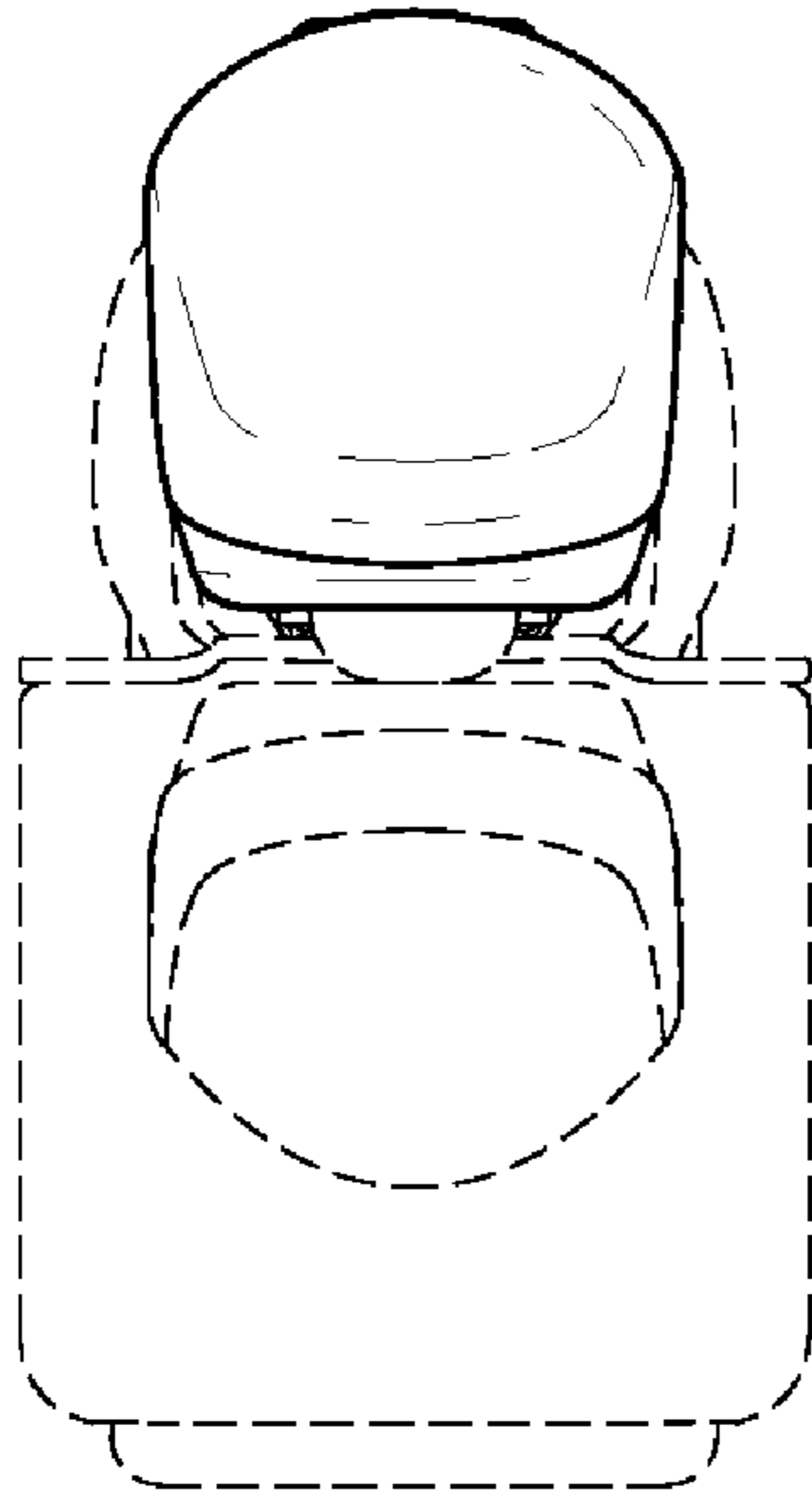

FIG. 6

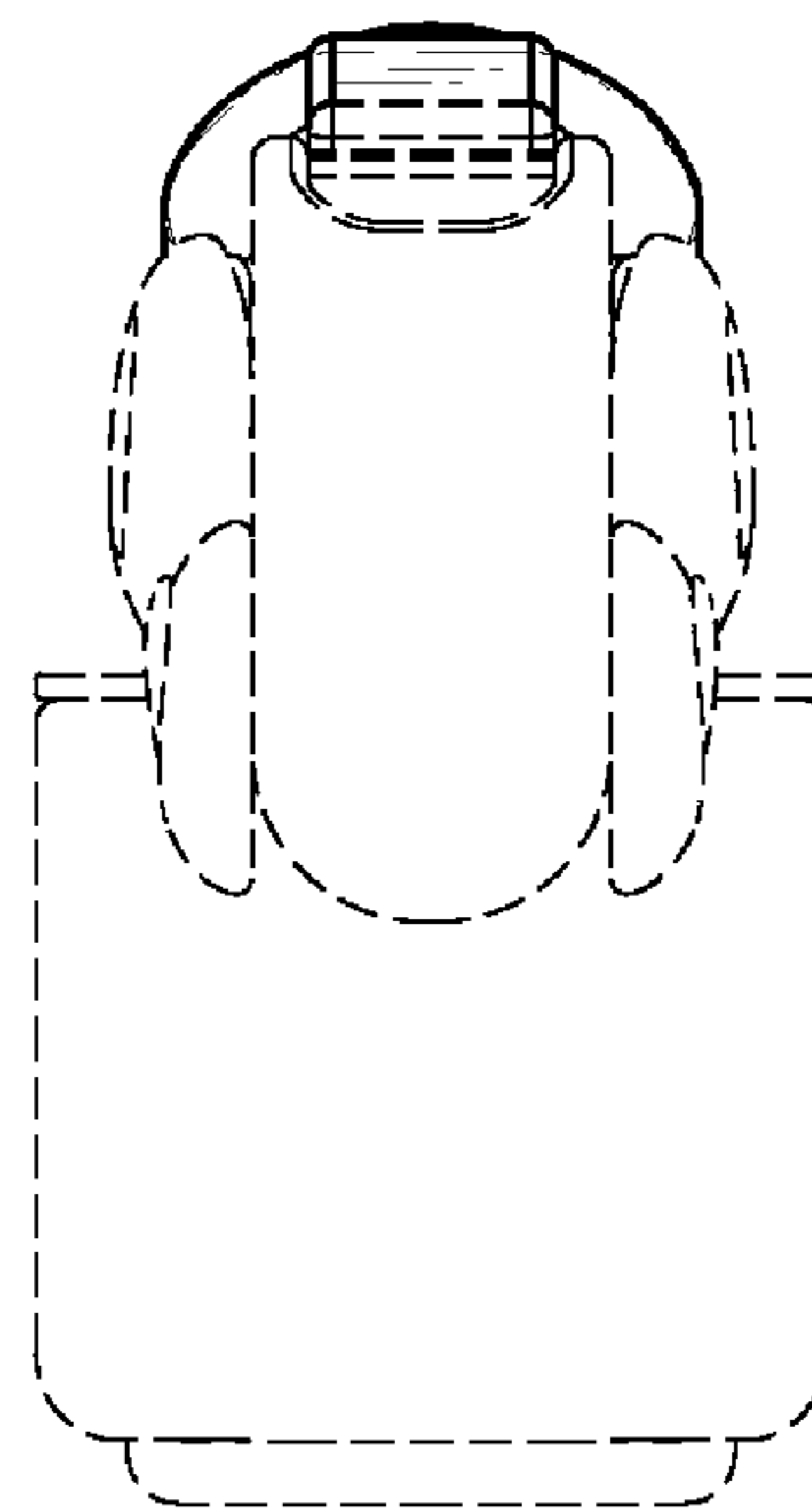

FIG. 7