



US00D619947S

(12) **United States Design Patent**
Tirey et al.

(10) **Patent No.:** **US D619,947 S**
(45) **Date of Patent:** **** Jul. 20, 2010**

(54) **INSTRUMENT CLUSTER OF A TRUCK VEHICLE**

(75) Inventors: **Robert Scott Tirey**, Fort Wayne, IN (US); **Bruce Youngs**, Novi, MI (US); **Pradhan Subhransu**, Akurdi, IN (US); **Corey Wilson**, Fort Wayne, IN (US); **Kwan Lee**, Overland Park, KS (US)

(73) Assignee: **Mahindra Navistar Automotives Limited** (IN)

(**) Term: **14 Years**

(21) Appl. No.: **29/355,381**

(22) Filed: **Feb. 5, 2010**

(51) **LOC (9) Cl.** **12-16**

(52) **U.S. Cl.** **D12/192**

(58) **Field of Classification Search** D12/192, D12/415; 180/190; 280/750-752; 296/190.01-190.09, 296/70; D15/17, 28; D10/46, 98, 102-103
See application file for complete search history.

(56) **References Cited**

U.S. PATENT DOCUMENTS

D54,139 S * 11/1919 Smith D12/192

D494,518 S * 8/2004 Kraus et al. D12/192
D504,370 S * 4/2005 Kraus D12/192
D546,744 S * 7/2007 Fukumoto et al. D12/192
D549,627 S * 8/2007 Esaki D12/192
D562,748 S * 2/2008 Tanaka et al. D12/192
D571,271 S * 6/2008 Esaki et al. D12/192
D586,277 S * 2/2009 Yamazaki et al. D12/192
D601,069 S * 9/2009 Corradi D12/192

* cited by examiner

Primary Examiner—Stacia Cadmus

(74) *Attorney, Agent, or Firm*—Jeffrey P. Calfa; Mark C. Bach; Gerald W. Askew

(57) **CLAIM**

The ornamental design for an instrument cluster of a truck vehicle, as shown and described.

DESCRIPTION

FIG. 1 is a right, front perspective view of an instrument cluster of a truck vehicle showing our new design;
FIG. 2 is a top view thereof;
FIG. 3 is a left view thereof; and,
FIG. 4 is a front view thereof.

1 Claim, 2 Drawing Sheets

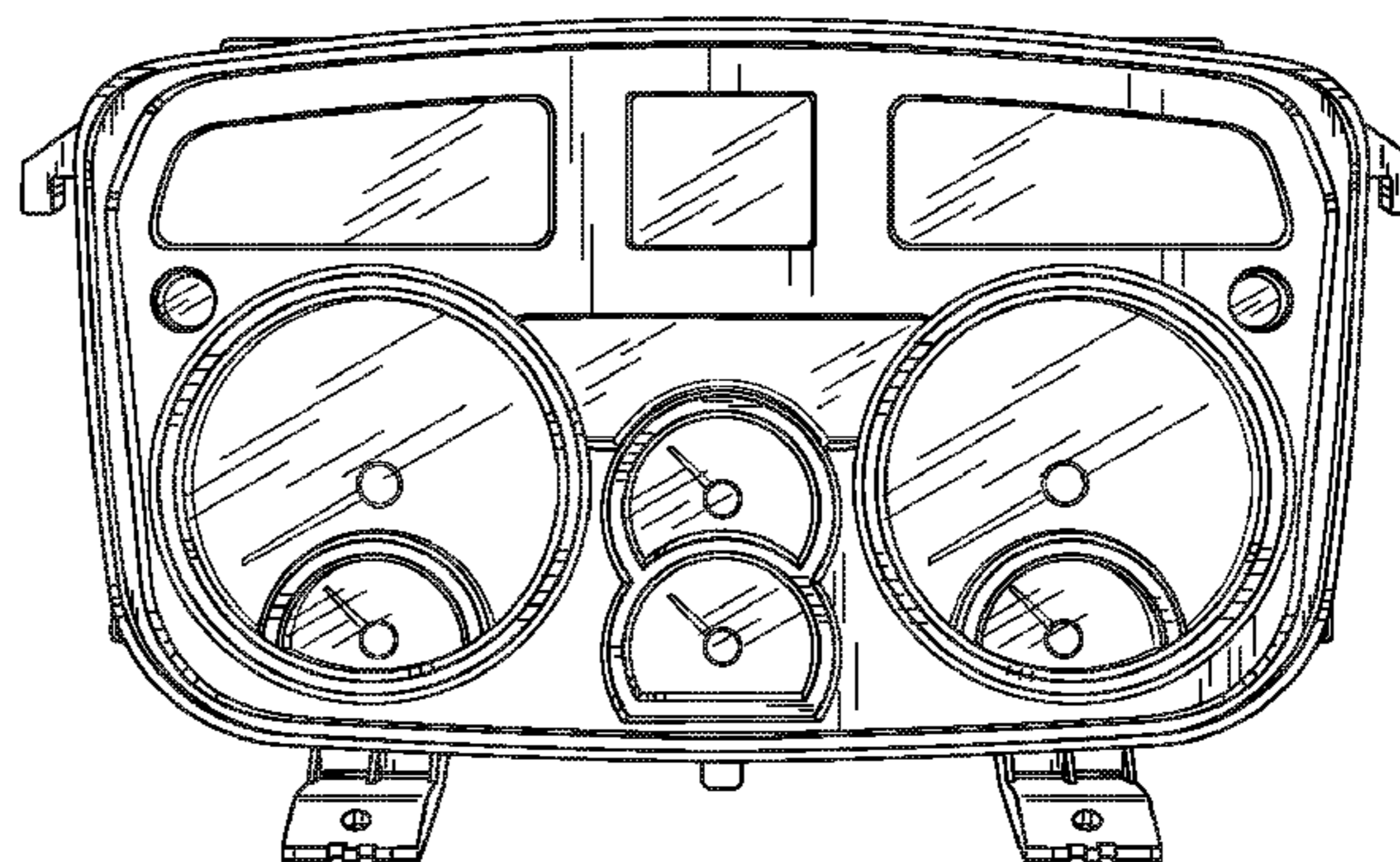
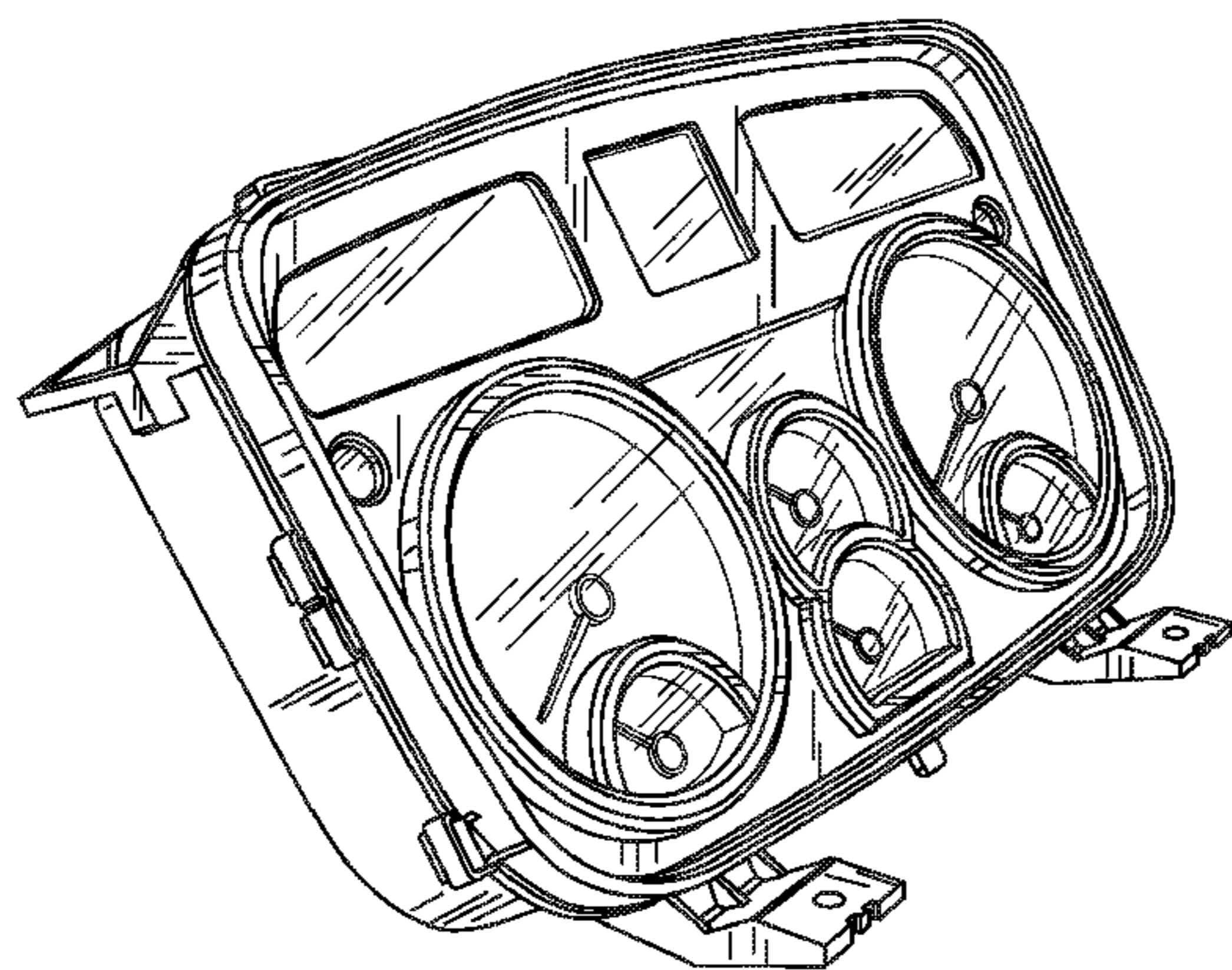

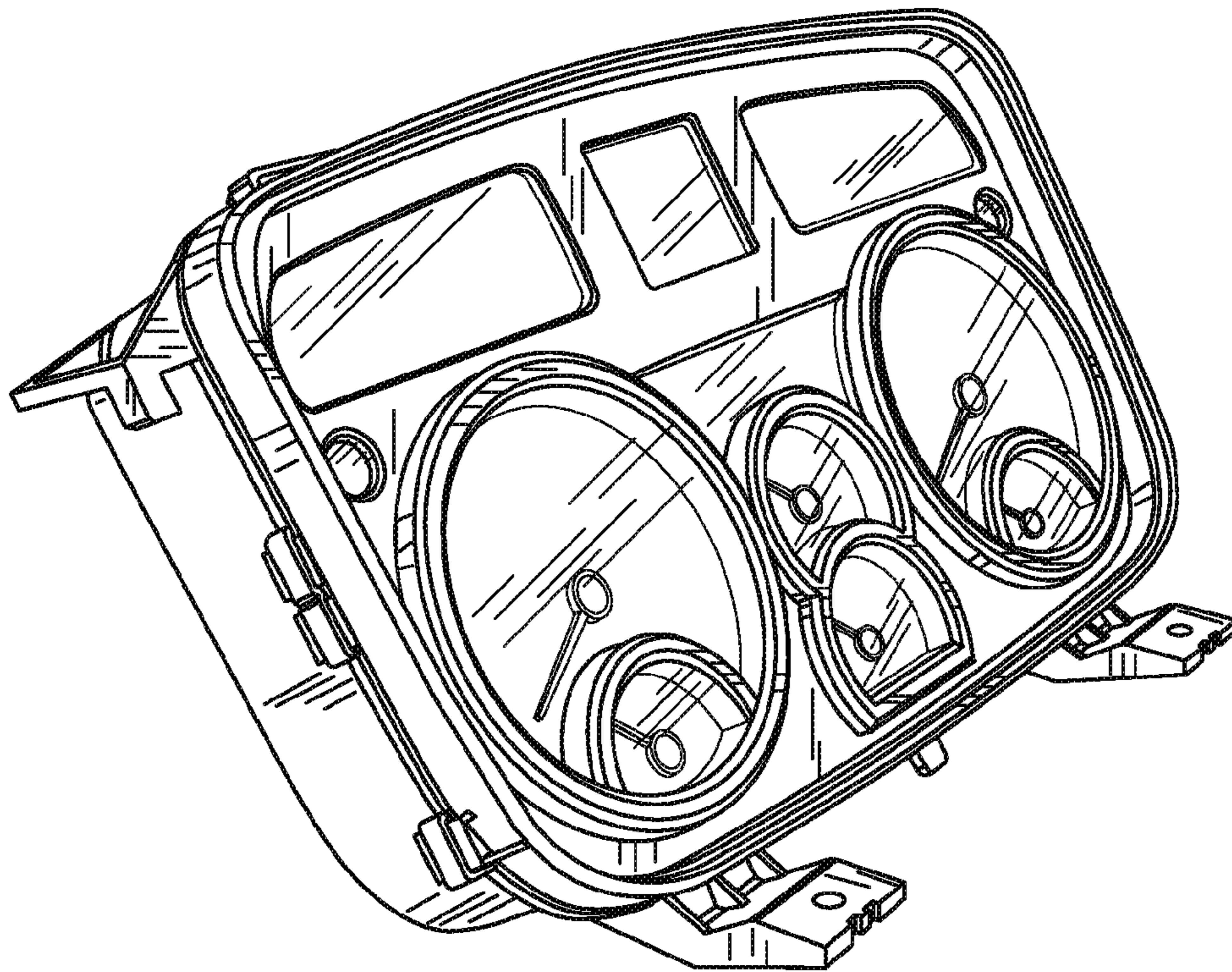

FIG. 1

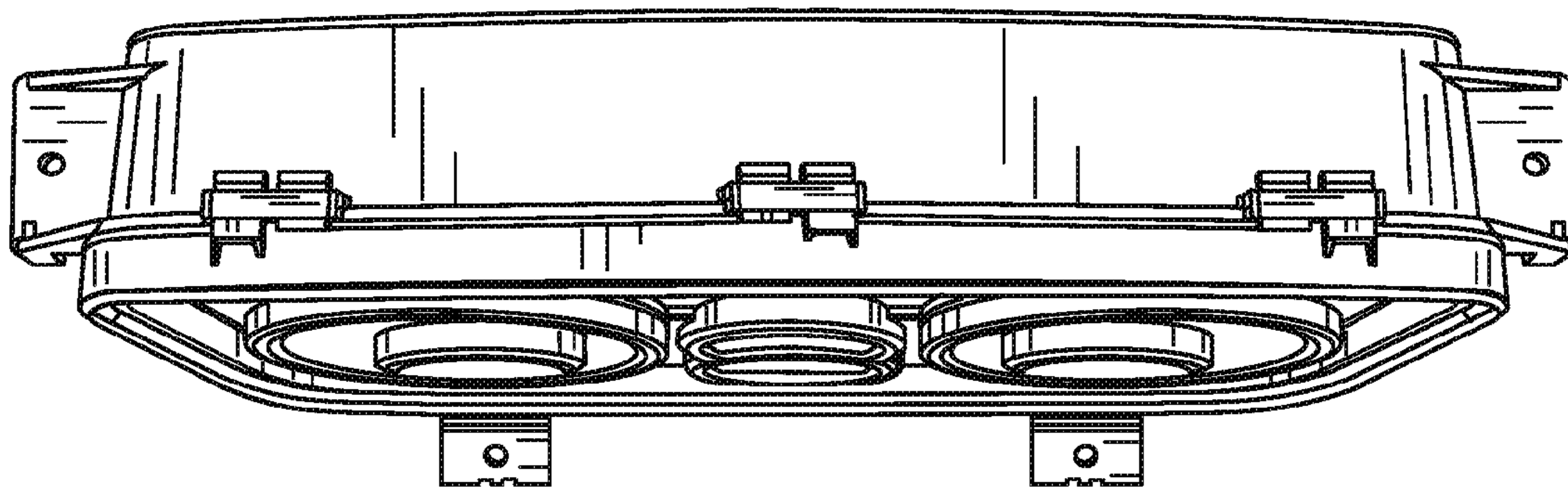

FIG. 2

FIG. 3

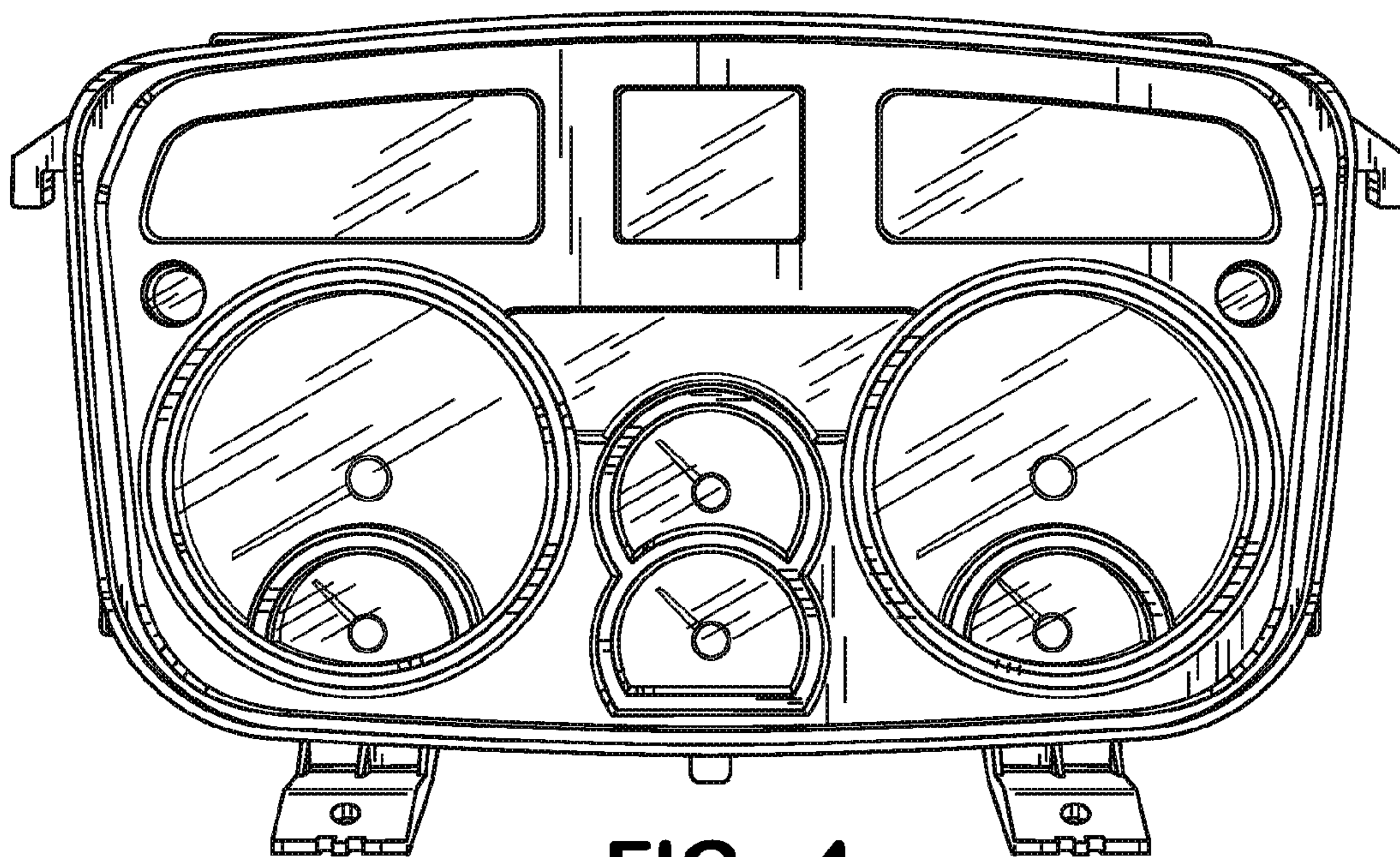
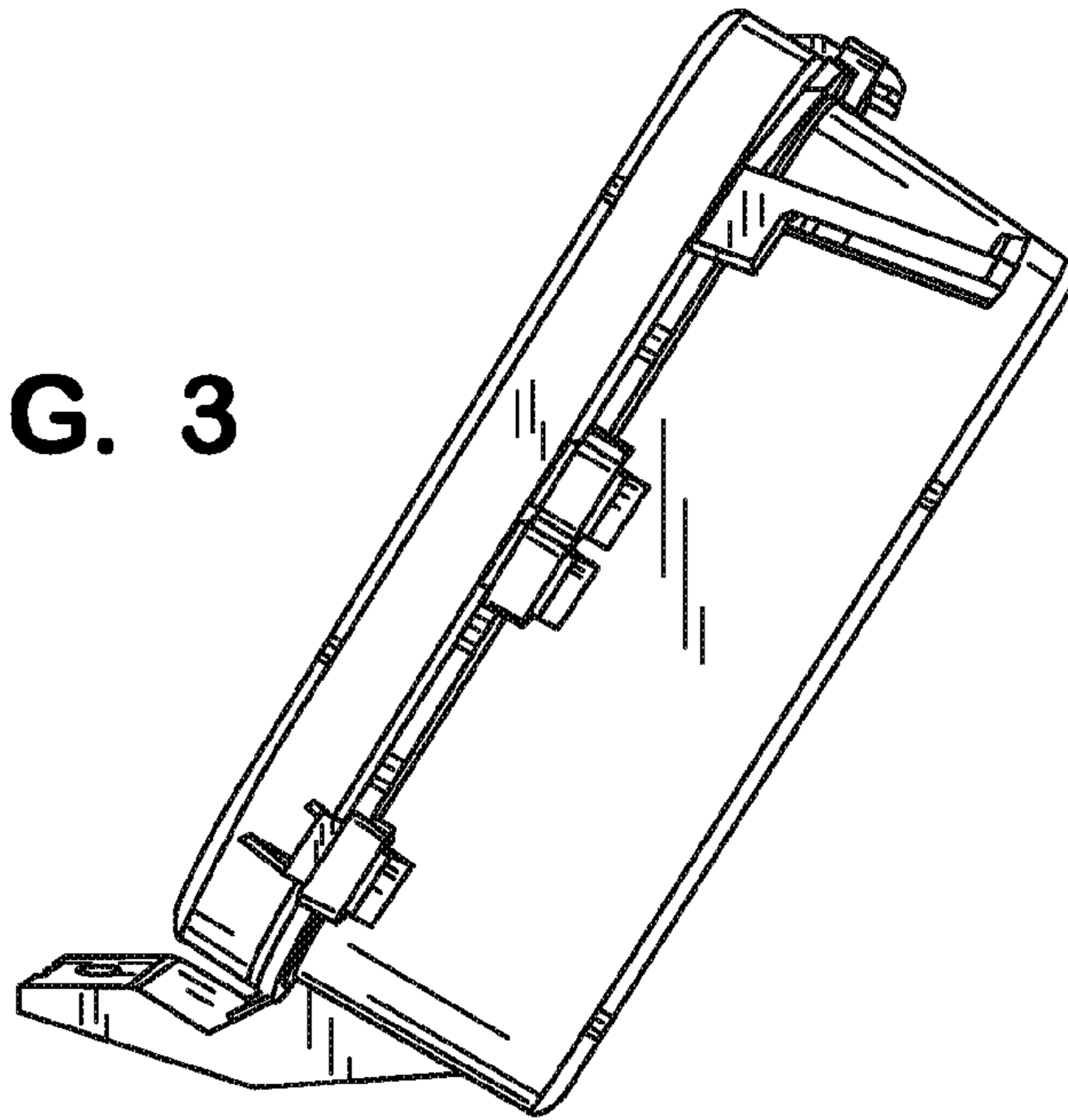

FIG. 4