



US00D619391S

(12) **United States Design Patent**
Bock

(10) **Patent No.:** **US D619,391 S**
(45) **Date of Patent:** **** Jul. 13, 2010**

(54) **SEAT BODY FOR A COMMERCIAL AIRCRAFT PASSENGER CABIN**

U.S. Appl. No. 29/250,825. Title: Partition Layout for a Commercial Aircraft Passenger Cabin, filed Dec. 1, 2006.

(75) Inventor: **Thomas-Mathias Bock**, Grenade sur Garonne (FR)

(Continued)

Primary Examiner—Caron Veynar

Assistant Examiner—Abraham Bahta

(73) Assignee: **Airbus SAS**, Blagnac Cedex (FR)

(74) *Attorney, Agent, or Firm*—Osler, Hoskin & Harcourt LLP

(**) Term: **14 Years**

(21) Appl. No.: **29/250,831**

(57) **CLAIM**

(22) Filed: **Dec. 1, 2006**

The ornamental design for a seat body for a commercial aircraft passenger cabin, as shown and described.

(51) **LOC (9) Cl.** **06-01**

(52) **U.S. Cl.** **D6/501**

(58) **Field of Classification Search** D6/356,
D6/334–336, 364, 365, 367, 374–375, 500–502;
D12/195, 345; 297/452.21, 452.29, 452.35,
297/452.38, 284.4; 244/118.5, 118.6
See application file for complete search history.

DESCRIPTION

(56) **References Cited**

U.S. PATENT DOCUMENTS

D357,363 S *	4/1995	Frankhouse et al.	D6/356
D510,816 S *	10/2005	Lee	D6/356
D541,541 S *	5/2007	Begin et al.	D6/356
D558,992 S *	1/2008	Bock	D6/356
D577,502 S *	9/2008	Fissette et al.	D6/356
D577,503 S *	9/2008	Priestman	D6/356
D583,579 S *	12/2008	Pearson et al.	D6/356
D590,161 S *	4/2009	Scoley et al.	D6/356
D591,520 S *	5/2009	Orson et al.	D6/356

FIG. 1 is a front-left side perspective view of a seat body for a commercial aircraft passenger cabin according to my design;

FIG. 2 is a top plan view thereof;

FIG. 3 is a right side elevation view thereof;

FIG. 4 is a left side elevation view thereof;

FIG. 5 is a front elevation view thereof;

FIG. 6 is a rear elevation view thereof;

FIG. 7 is a front-left side perspective view of the seat body of FIG. 1 shown with a commercial aircraft passenger cabin ottoman and partitions;

FIG. 8 is a top plan view of the seat body, ottoman and partitions shown in FIG. 7;

FIG. 9 is a front-left side perspective view of the seat body of FIG. 1 shown in a commercial aircraft passenger cabin; and,

FIG. 10 is a top plan view of the seat body and cabin shown in FIG. 9.

No bottom plan view is included as no features of the claimed design are visible therein.

Throughout the Figures, the broken lines showing environment or structure are for illustrative purposes only and form no part of the claimed design.

OTHER PUBLICATIONS

U.S. Appl. No. 29/250,809. Title: Partition for a Commercial Aircraft Passenger Cabin, filed Dec. 1, 2006.

U.S. Appl. No. 29/250,814. Title: Partition for a Commercial Aircraft Passenger Cabin, filed Dec. 1, 2006.

U.S. Appl. No. 29/250,818. Title: Partition for a Commercial Aircraft Passenger Cabin, filed Dec. 1, 2006.

U.S. Appl. No. 29/250,828. Title: Partition for a Commercial Aircraft Passenger Cabin, filed Dec. 1, 2006.

U.S. Appl. No. 29/250,826. Title: Seat Layout for a Commercial Aircraft Passenger Cabin, filed Dec. 1, 2006.

1 Claim, 8 Drawing Sheets

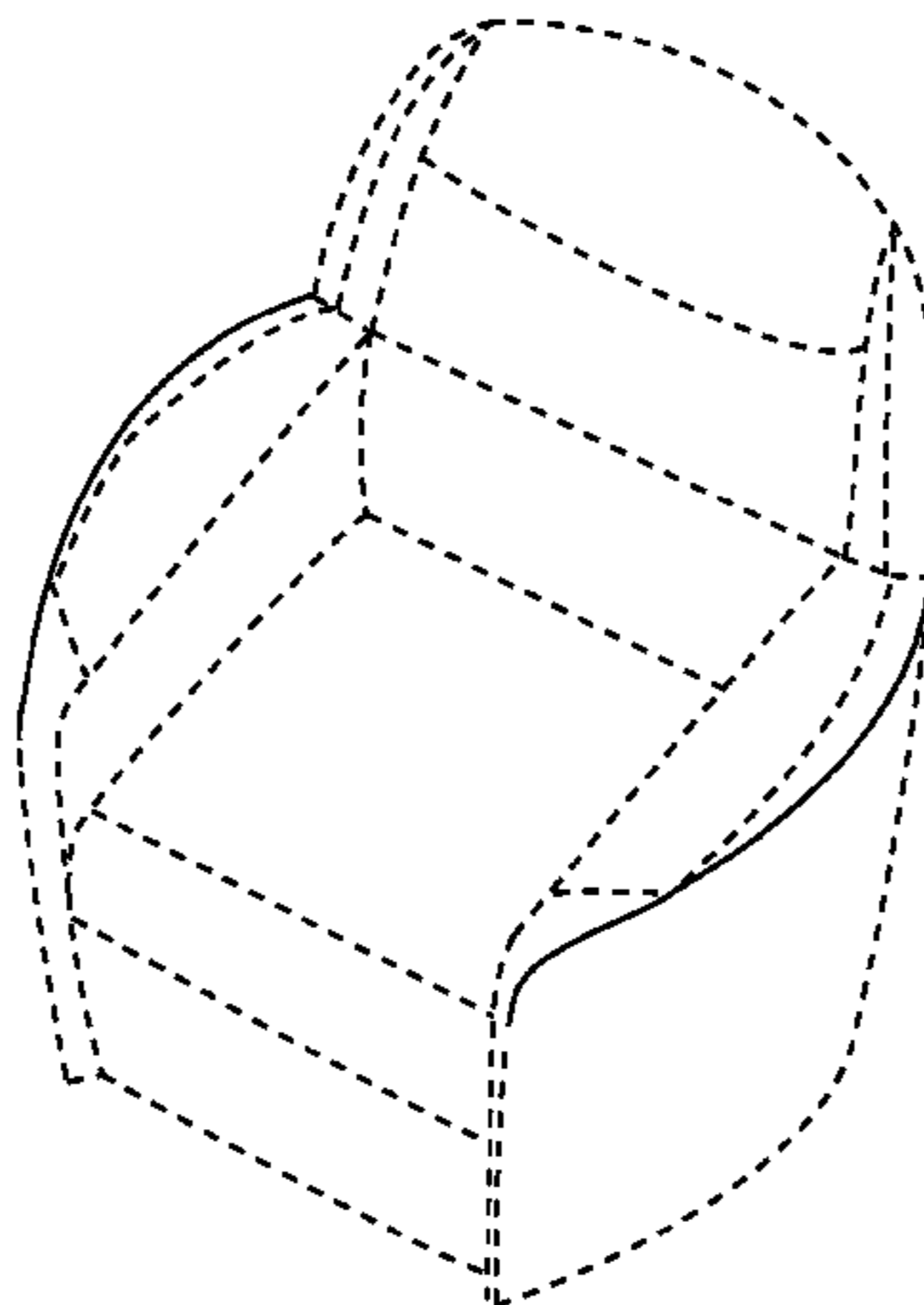

OTHER PUBLICATIONS

U.S. Appl. No. 29/250,833. Title: Partition Layout for a Commercial Aircraft Passenger Cabin, filed Dec. 1, 2006.

U.S. Appl. No. 29/250,834. Title: Partition Layout for a Commercial Aircraft Passenger Cabin, filed Dec. 1, 2006.

U.S. Appl. No. 29/250,832. Title: Ottoman for a Commercial Aircraft Passenger Cabin, filed Dec. 1, 2006.

U.S. Appl. No. 29/250,811. Title: Seat for a Commercial Aircraft Passenger Cabin, filed Dec. 1, 2006.

U.S. Appl. No. 29/250,810. Title: Furniture for a Commercial Aircraft Passenger Cabin, filed Dec. 1, 2006.

U.S. Appl. No. 29/250,829. Title: Furniture for a Commercial Aircraft Passenger Cabin, filed Dec. 1, 2006.

U.S. Appl. No. 29/250,813. Title: Armrest/Backrest Combination for an Ottoman for a Commercial Aircraft Passenger Cabin, filed Dec. 1, 2006.

* cited by examiner

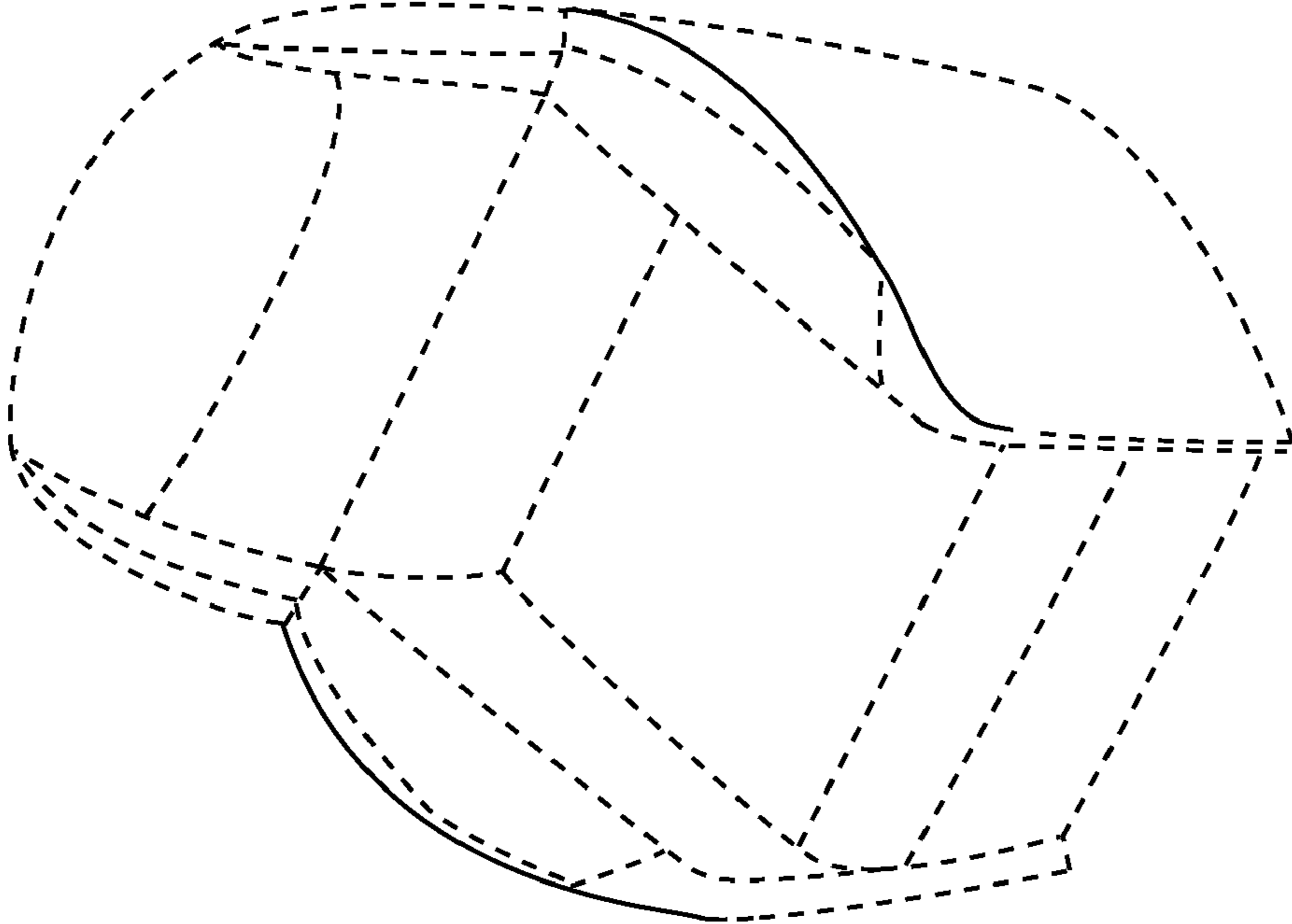

FIG. 1

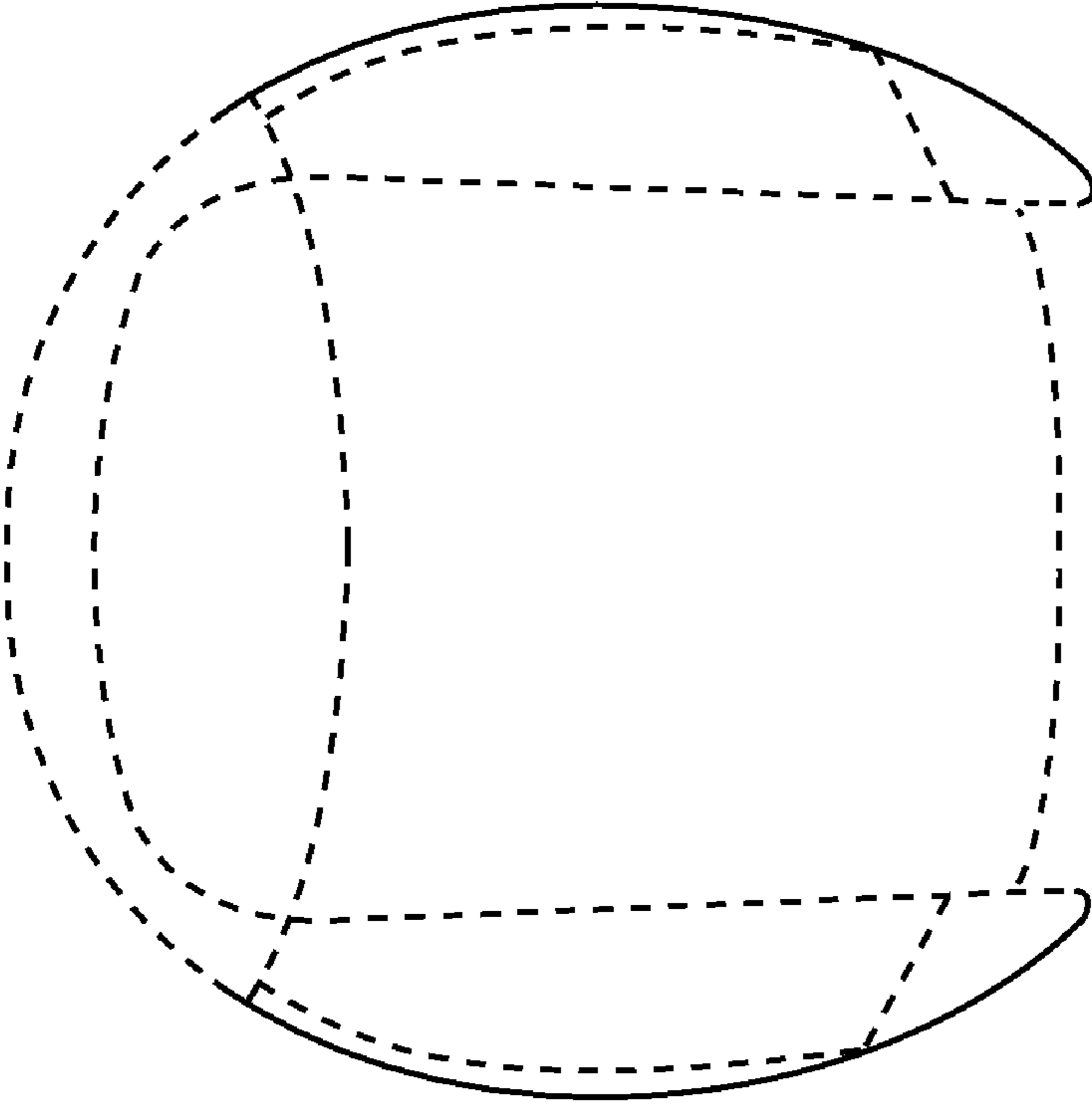

FIG. 2

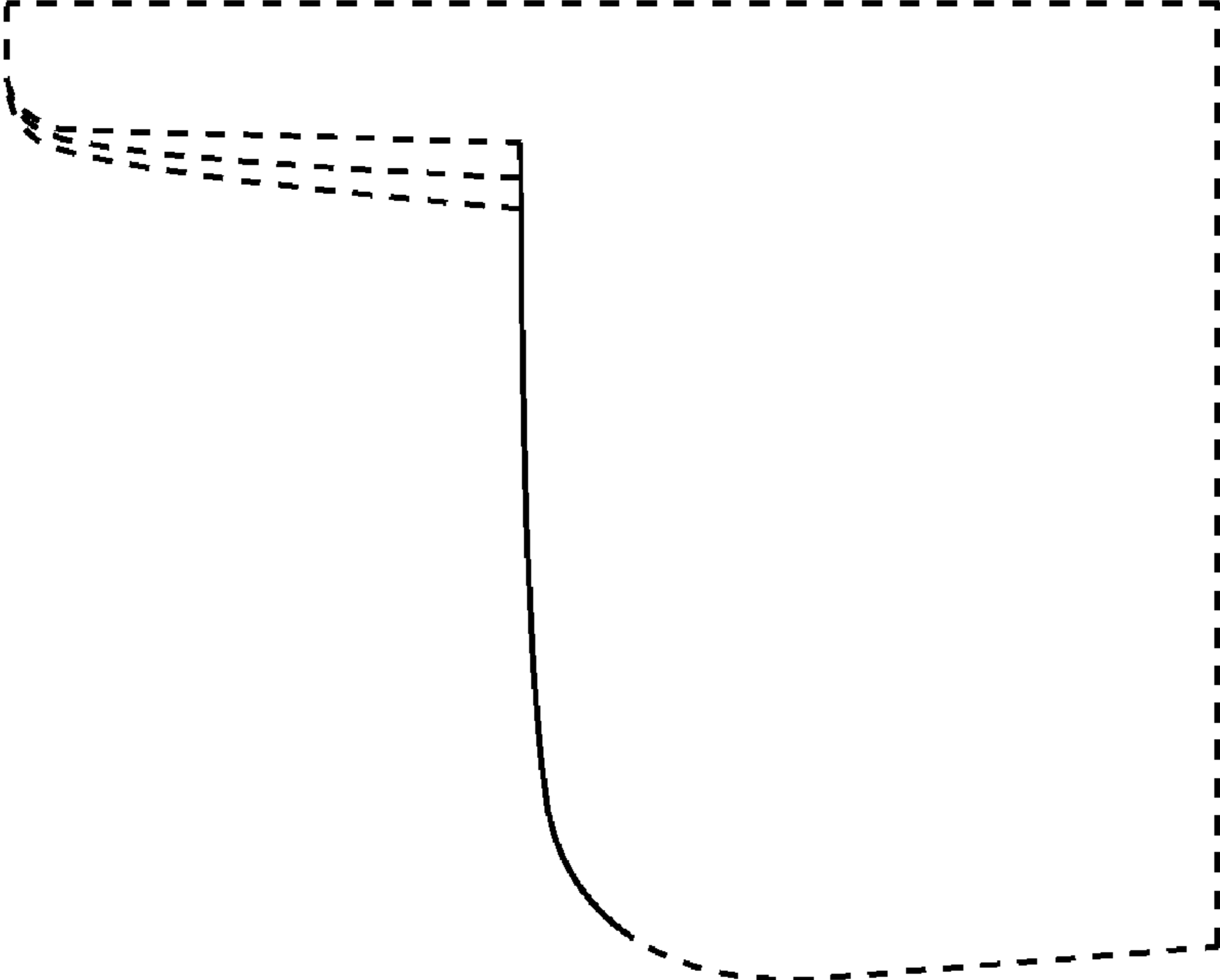

FIG. 3

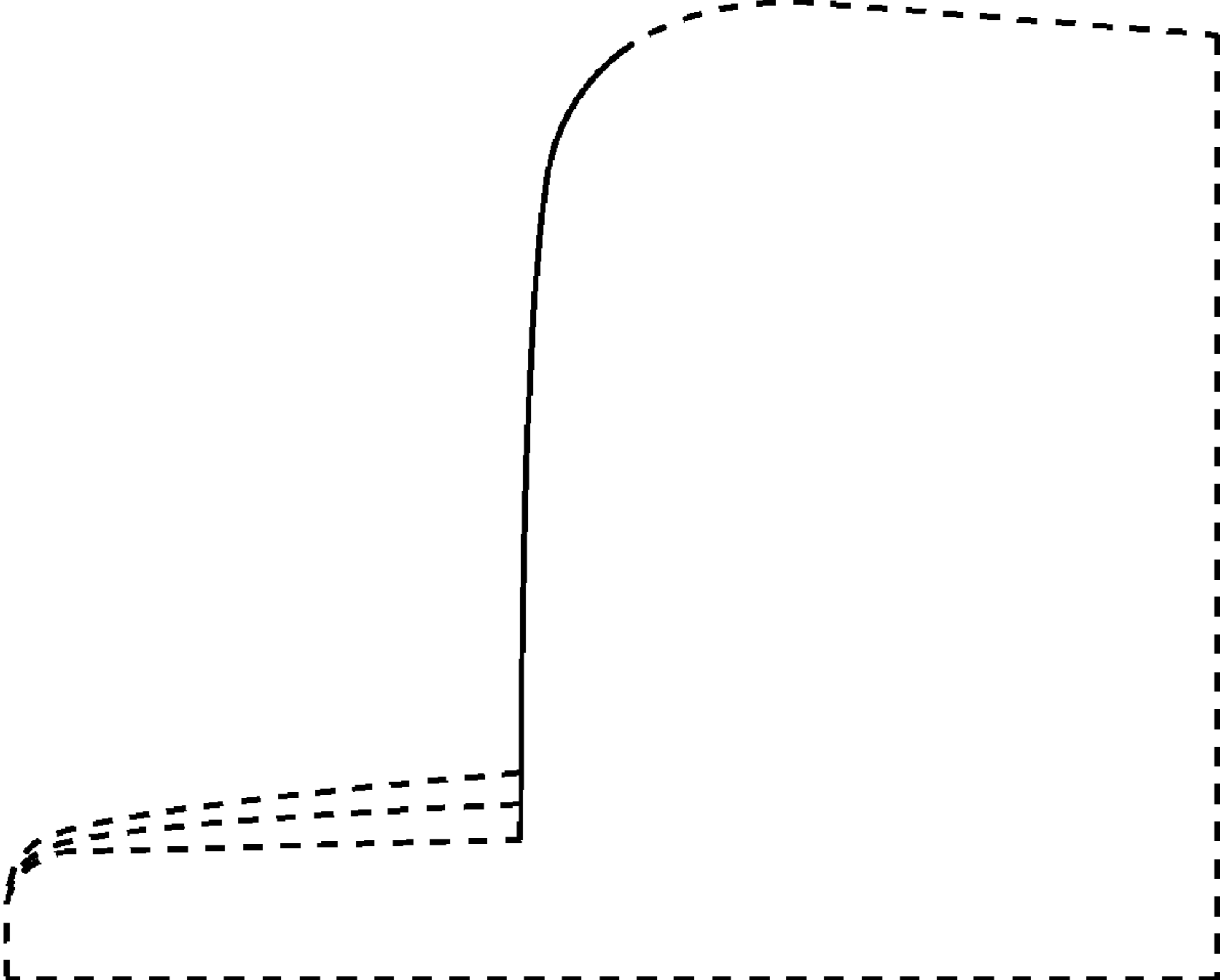

FIG. 4

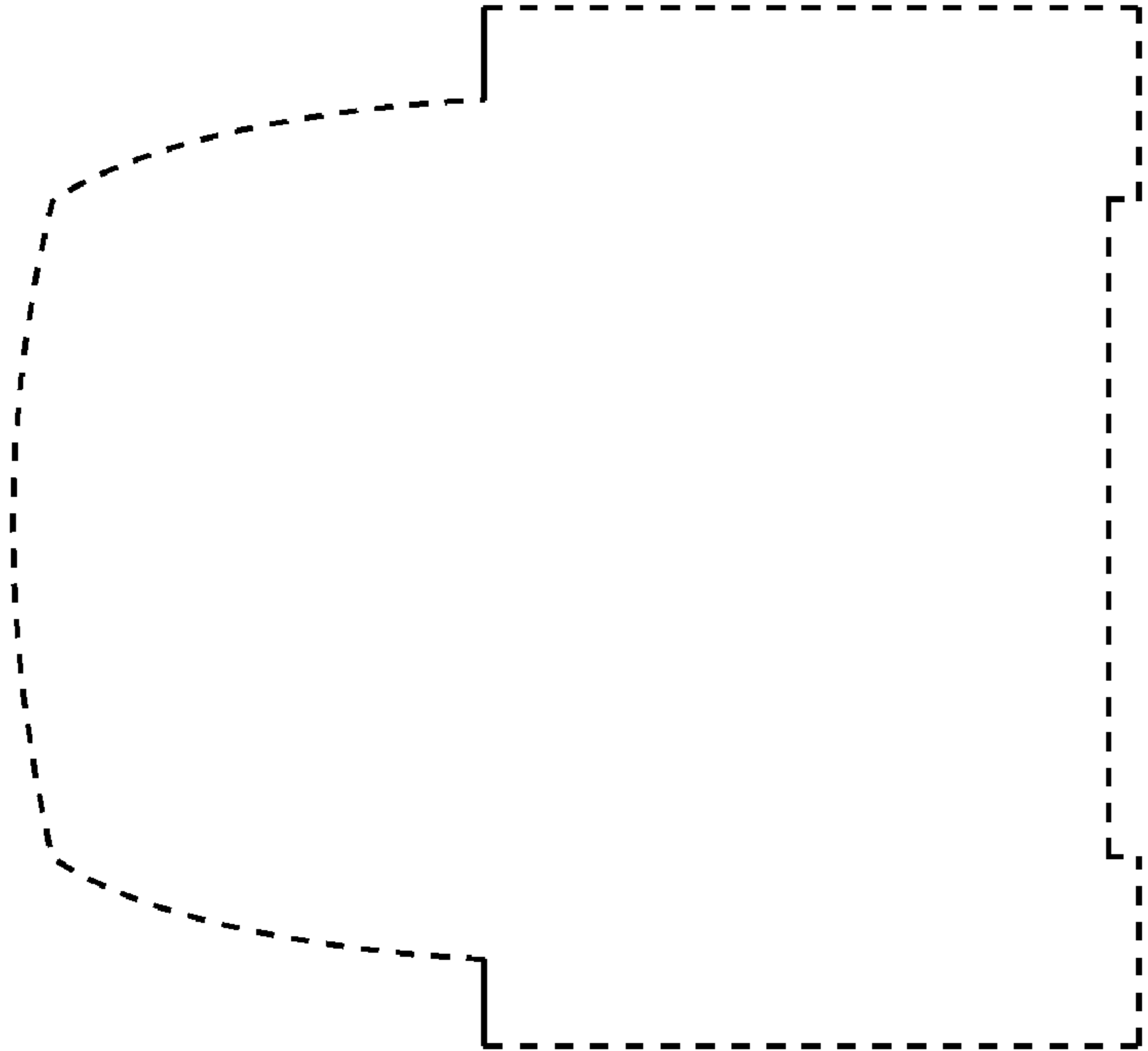

FIG. 6

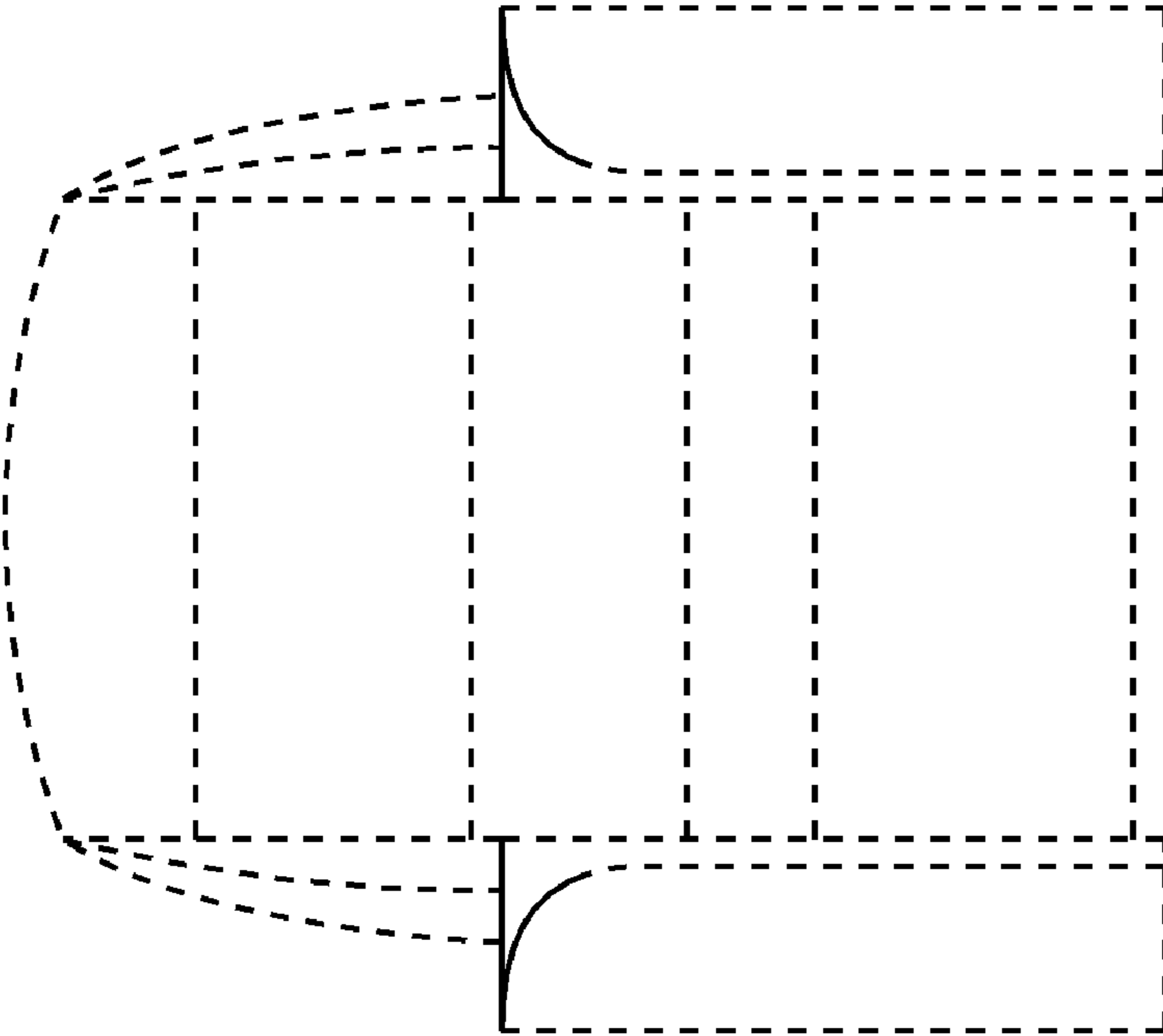

FIG. 5

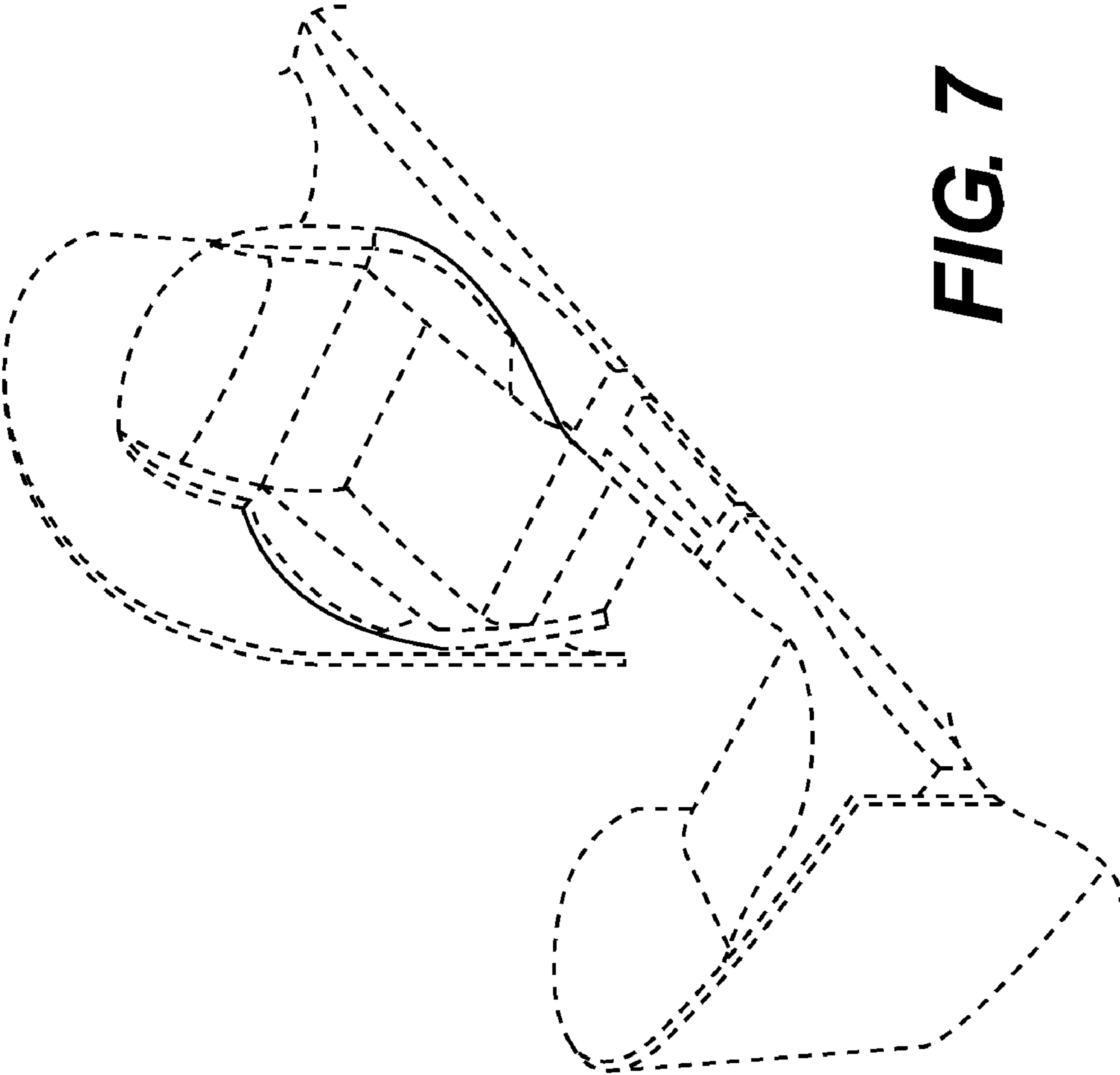

FIG. 7

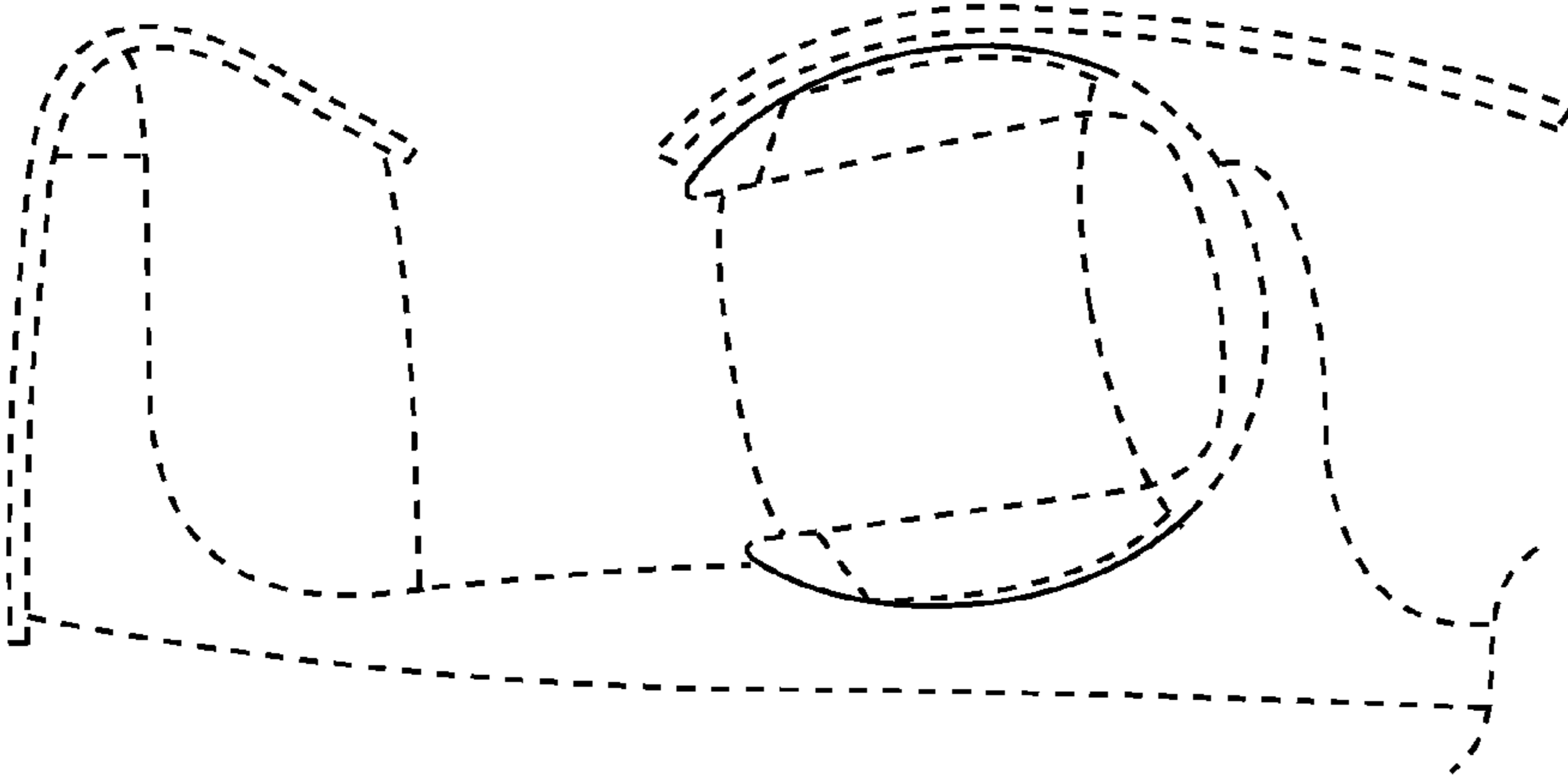

FIG. 8

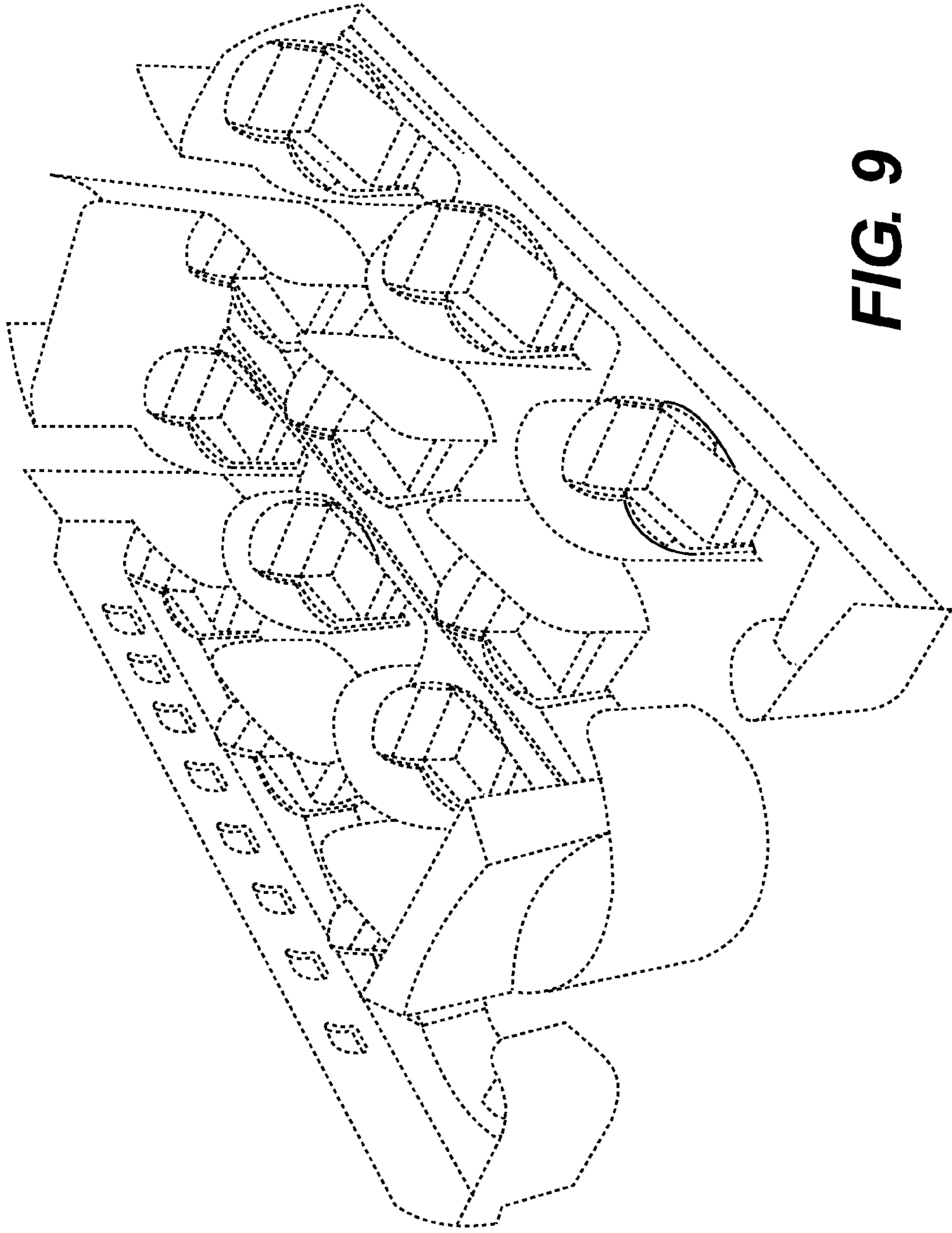

FIG. 9

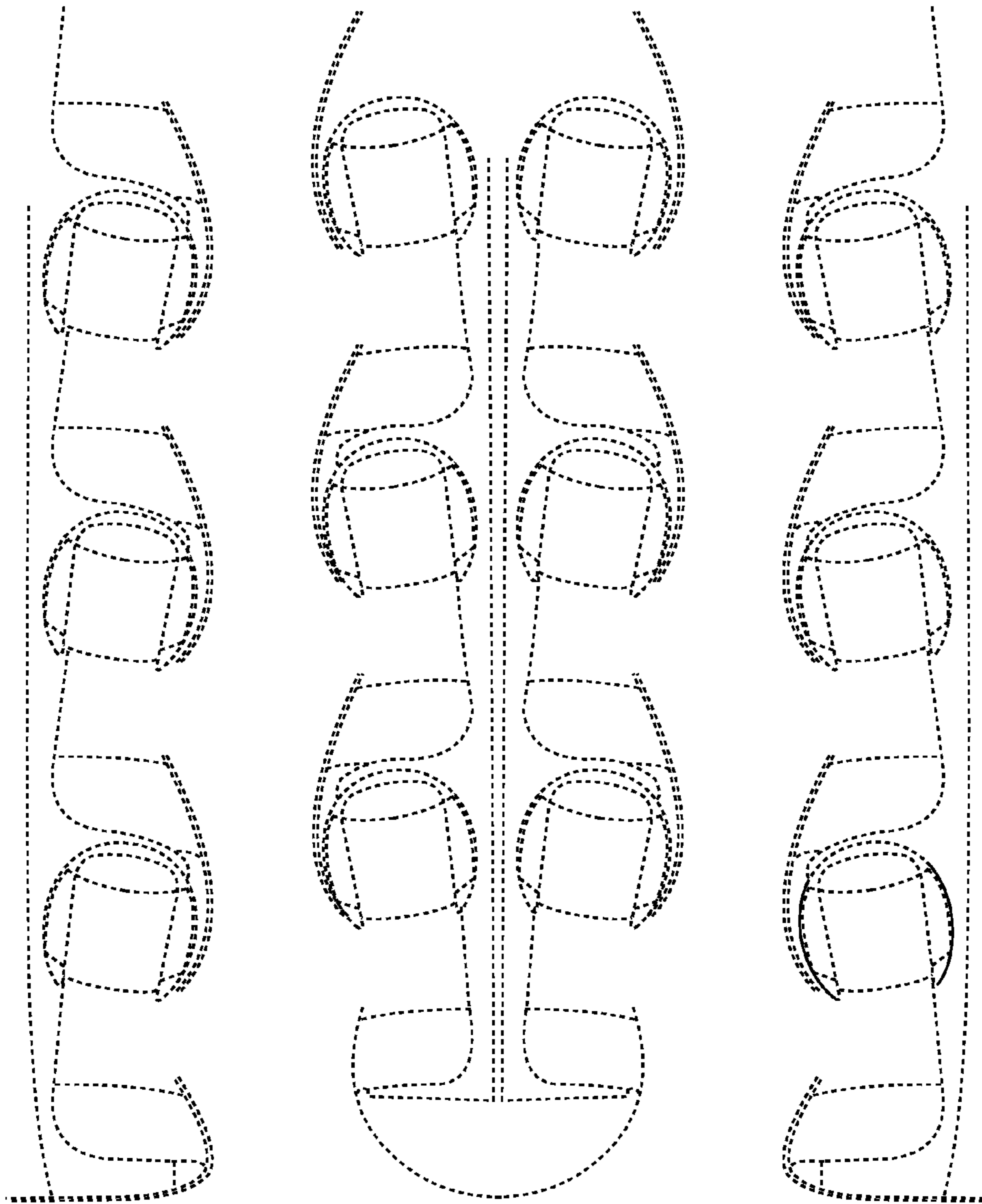

FIG. 10