



US00D619076S

(12) **United States Design Patent**
Guering

(10) **Patent No.:** **US D619,076 S**

(45) **Date of Patent:** **** Jul. 6, 2010**

(54) **AIRCRAFT**

(75) Inventor: **Bernard Guering**, Montrabe (FR)

(73) Assignee: **Airbus Operations S.A.S.**, Toulouse
Cedex (FR)

(**) Term: **14 Years**

(21) Appl. No.: **29/342,554**

(22) Filed: **Aug. 27, 2009**

Related U.S. Application Data

(62) Division of application No. 29/275,960, filed on Jan. 10, 2007.

Foreign Application Priority Data

Jul. 13, 2006	(EM)	000572334
Jul. 13, 2006	(EM)	000572342
Jul. 13, 2006	(EM)	000572383
Jul. 13, 2006	(EM)	000572391

(51) **LOC (9) Cl.** **12-07**

(52) **U.S. Cl.** **D12/343**

(58) **Field of Classification Search** D12/319,
D12/333, 341, 343, 345; D21/447, 448,
D21/582; 244/35 A, 45 A, 118.5, 119
See application file for complete search history.

(56) **References Cited**

U.S. PATENT DOCUMENTS

D370,456 S * 6/1996 Buchsel et al. D12/340

D515,012 S *	2/2006	Eatkins et al.	D12/319
D516,995 S *	3/2006	Eatkins et al.	D12/319
D537,029 S *	2/2007	Eakins et al.	D12/319
D576,938 S *	9/2008	Moon	D12/343
D589,867 S *	4/2009	Chesne et al.	D12/343

* cited by examiner

Primary Examiner—Cathron C. Brooks

Assistant Examiner—Maurice Stevens

(74) *Attorney, Agent, or Firm*—Osler, Hoskin & Harcourt
LLP

(57) **CLAIM**

The ornamental design for an aircraft, as shown and described.

DESCRIPTION

FIG. 1 is a left side elevation view of an aircraft according to my new design;

FIG. 2 is a top plan view thereof;

FIG. 3 is a front elevation view thereof;

FIG. 4 is a rear elevation view thereof;

FIG. 5 is a right side elevation view thereof; and,

FIG. 6 is a bottom plan view thereof.

1 Claim, 6 Drawing Sheets

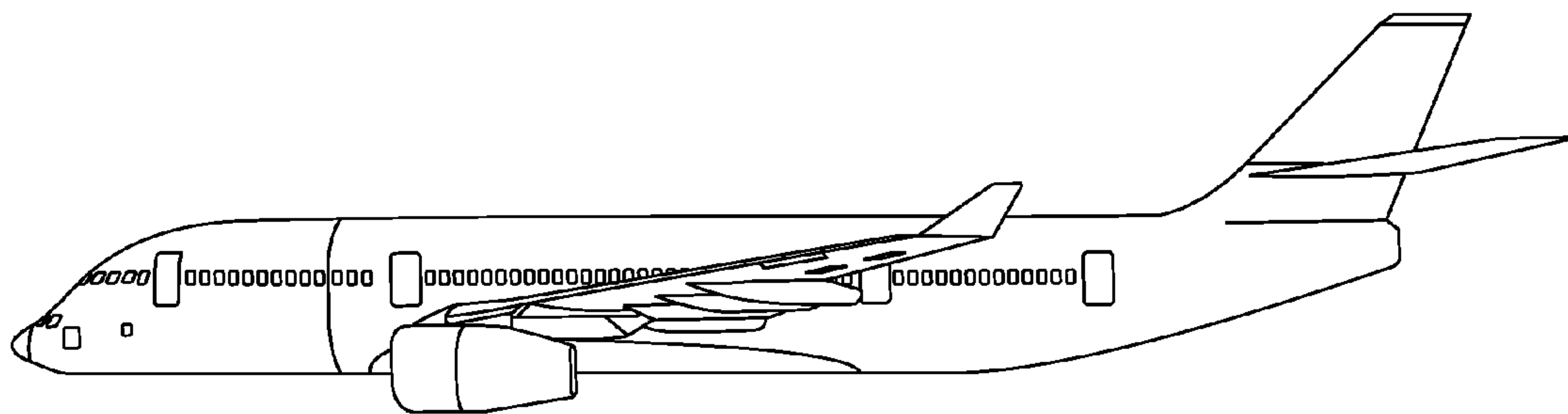

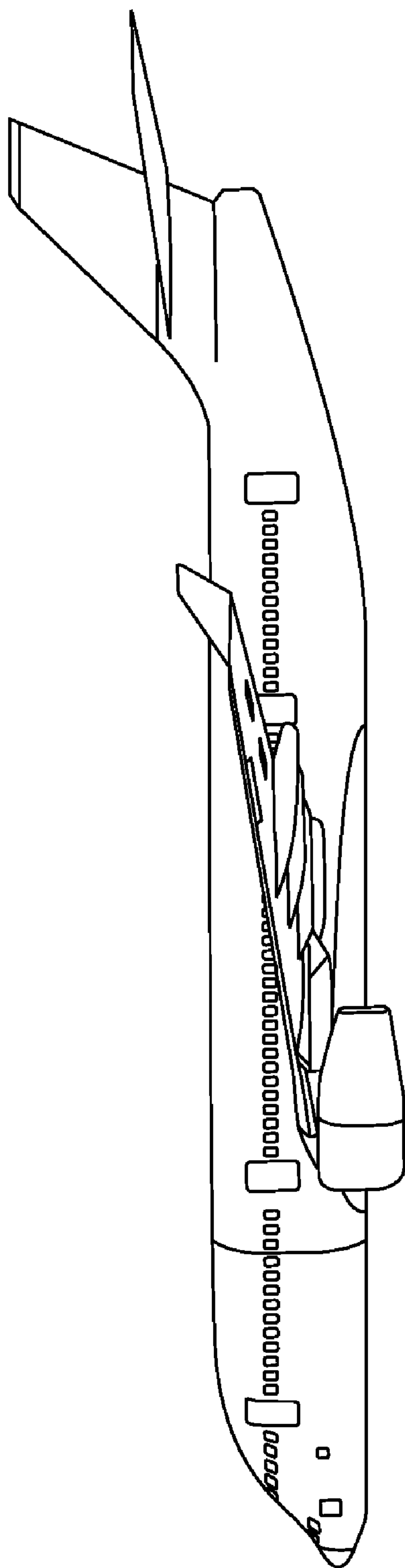

FIG. 1

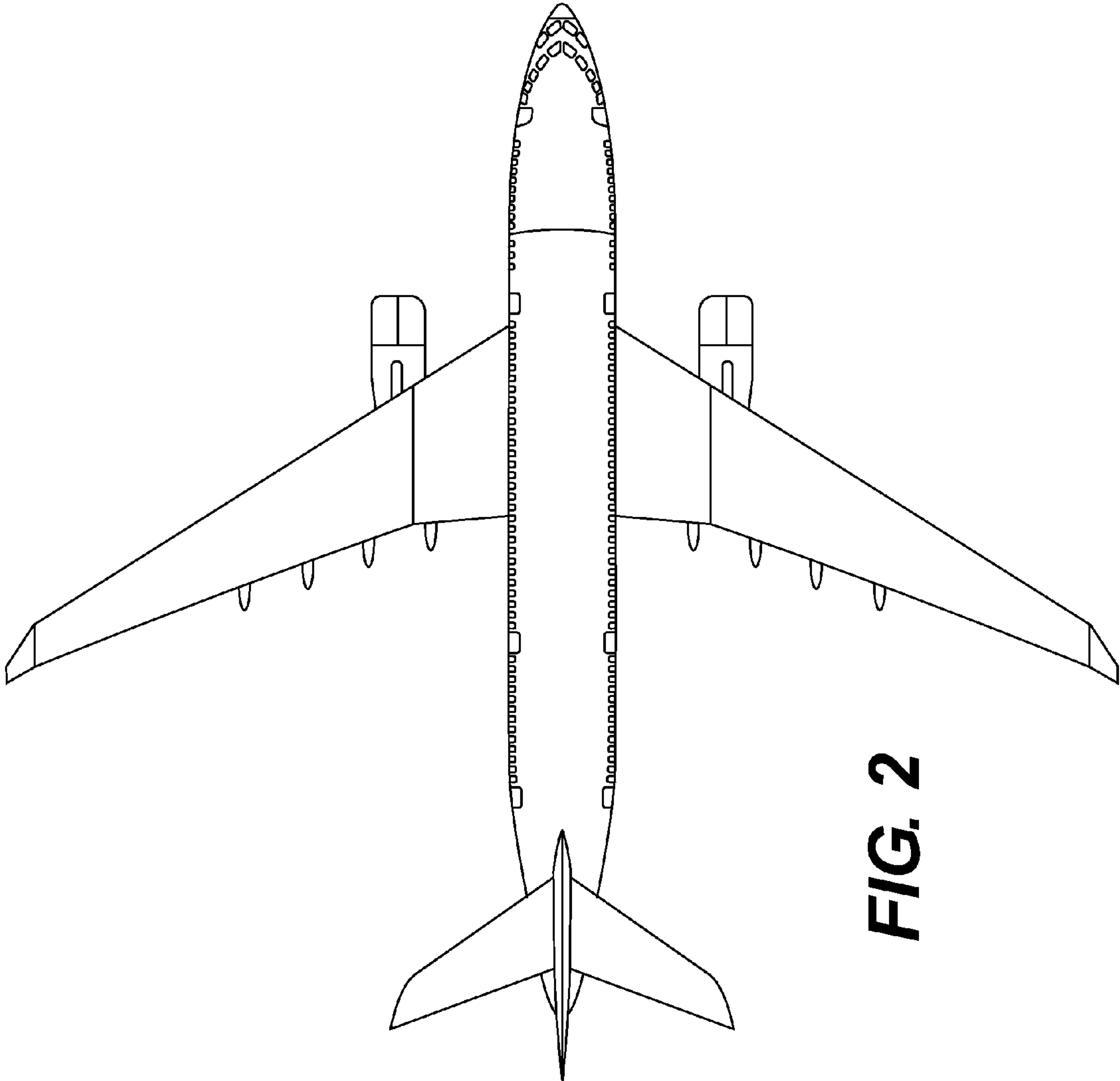

FIG. 2

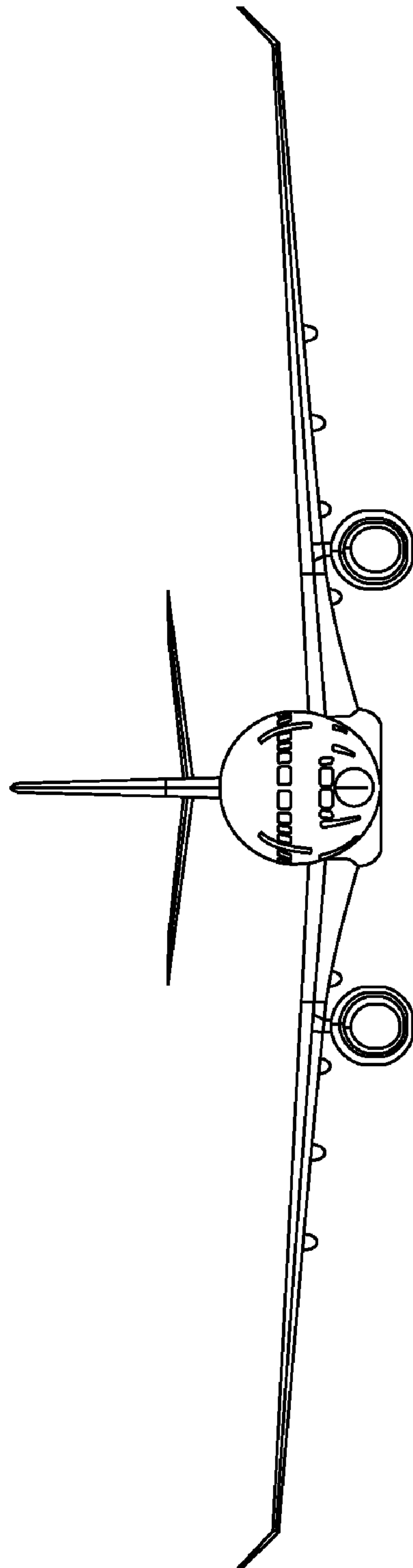

FIG. 3

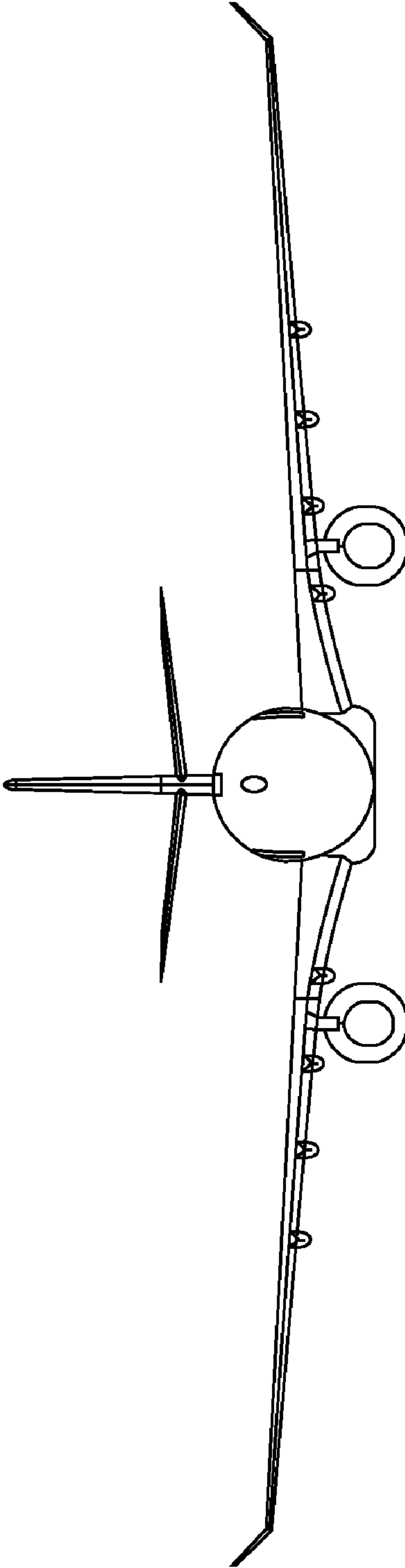

FIG. 4

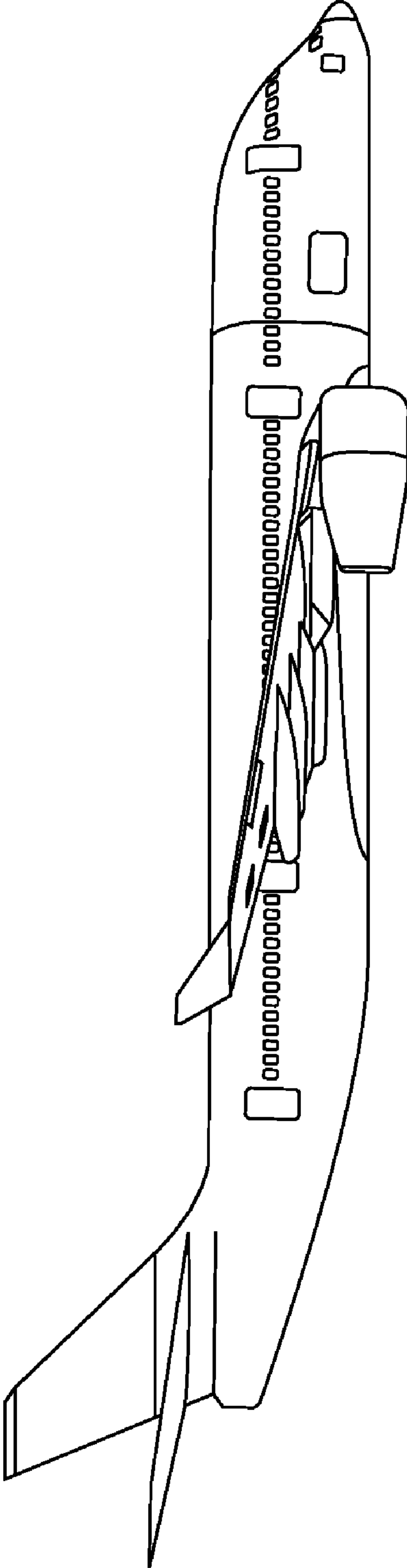

FIG. 5

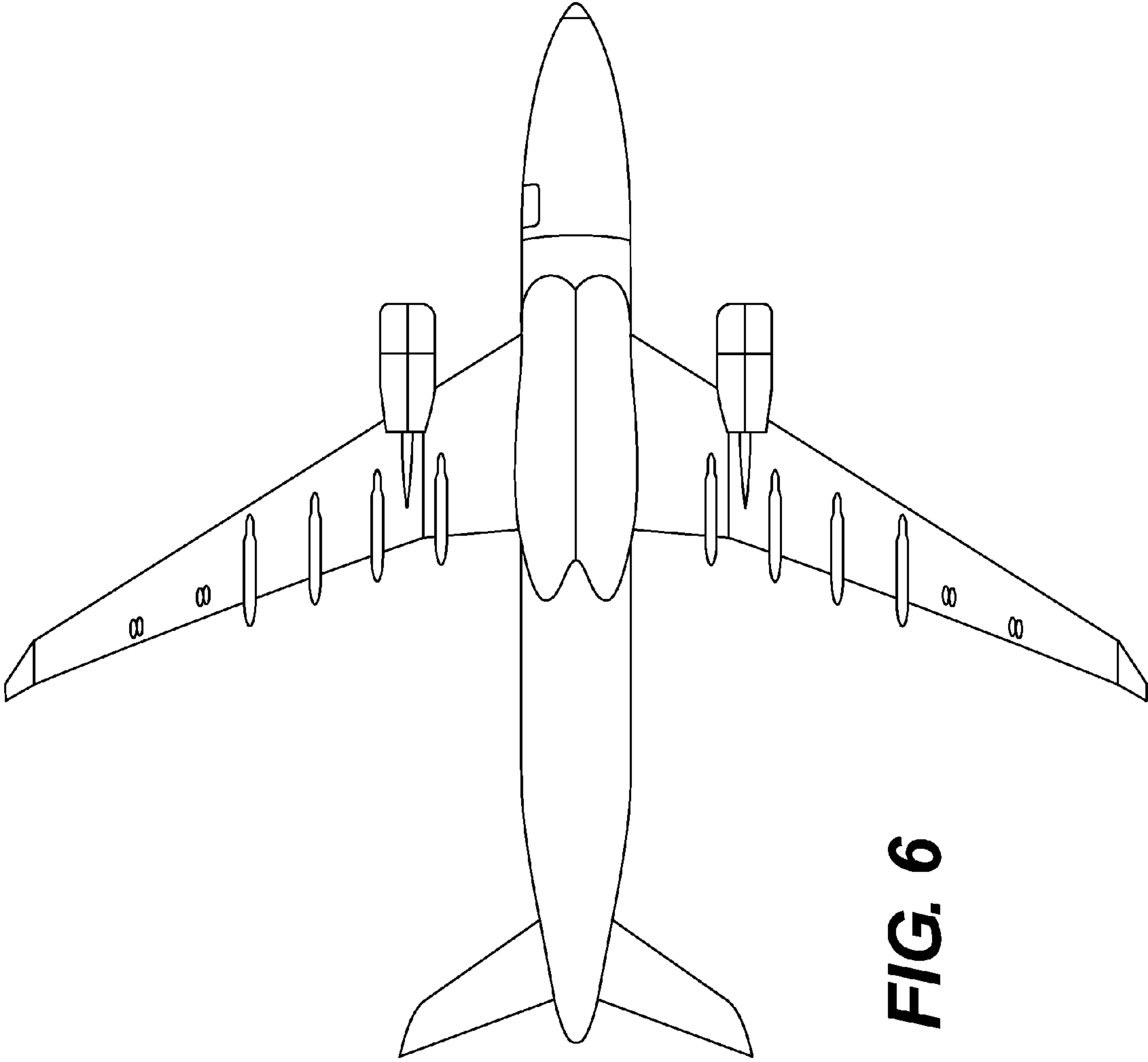

FIG. 6