



US00D618537S

(12) **United States Design Patent**
Panzer et al.

(10) **Patent No.:** **US D618,537 S**

(45) **Date of Patent:** **** Jun. 29, 2010**

(54) **HANGER FOR A REUSABLE SHOPPING BAG**

Primary Examiner—Holly H Baynham
(74) *Attorney, Agent, or Firm*—Sandy Lipkin

(76) Inventors: **David Panzer**, 3944 Maricopa Dr., Santa Barbara, CA (US) 93110; **Janae Panzer**, 3944 Maricopa Dr., Santa Barbara, CA (US) 93110

(57) **CLAIM**

The ornamental design for hanger for a reusable shopping bag, as shown and described.

(**) Term: **14 Years**

DESCRIPTION

(21) Appl. No.: **29/316,159**

FIG. 1 is a perspective view of the hanger for a reusable shopping bag.

(22) Filed: **Aug. 28, 2009**

FIG. 2 is a rear view of the hanger for a reusable shopping bag.

(51) **LOC (9) Cl.** **08-05**

(52) **U.S. Cl.** **D8/367**

FIG. 3 is a first side view of the hanger for a reusable shopping bag.

(58) **Field of Classification Search** D8/367,
D8/373; 248/301, 304, 215

See application file for complete search history.

FIG. 4 is a bottom view of the hanger for a reusable shopping bag.

(56) **References Cited**

U.S. PATENT DOCUMENTS

D497,255 S * 10/2004 Scola D3/328

D540,040 S * 4/2007 Madirazza D3/328

FIG. 5 is front view of the hanger for a reusable shopping bag.

FIG. 6 is a second side view of the hanger for a reusable shopping bag; and,

FIG. 7 is a top view of the hanger for a reusable shopping bag.

* cited by examiner

1 Claim, 3 Drawing Sheets

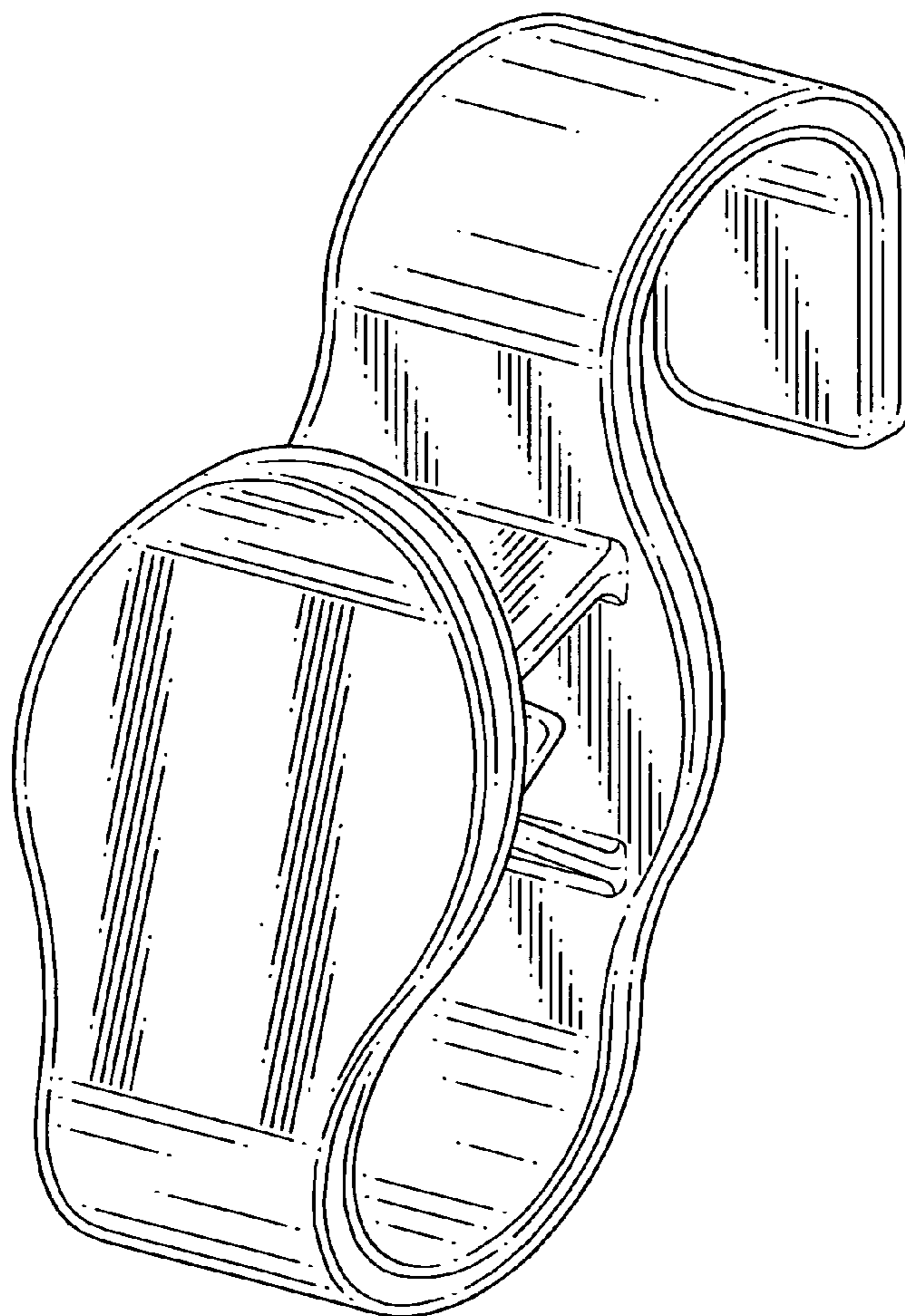

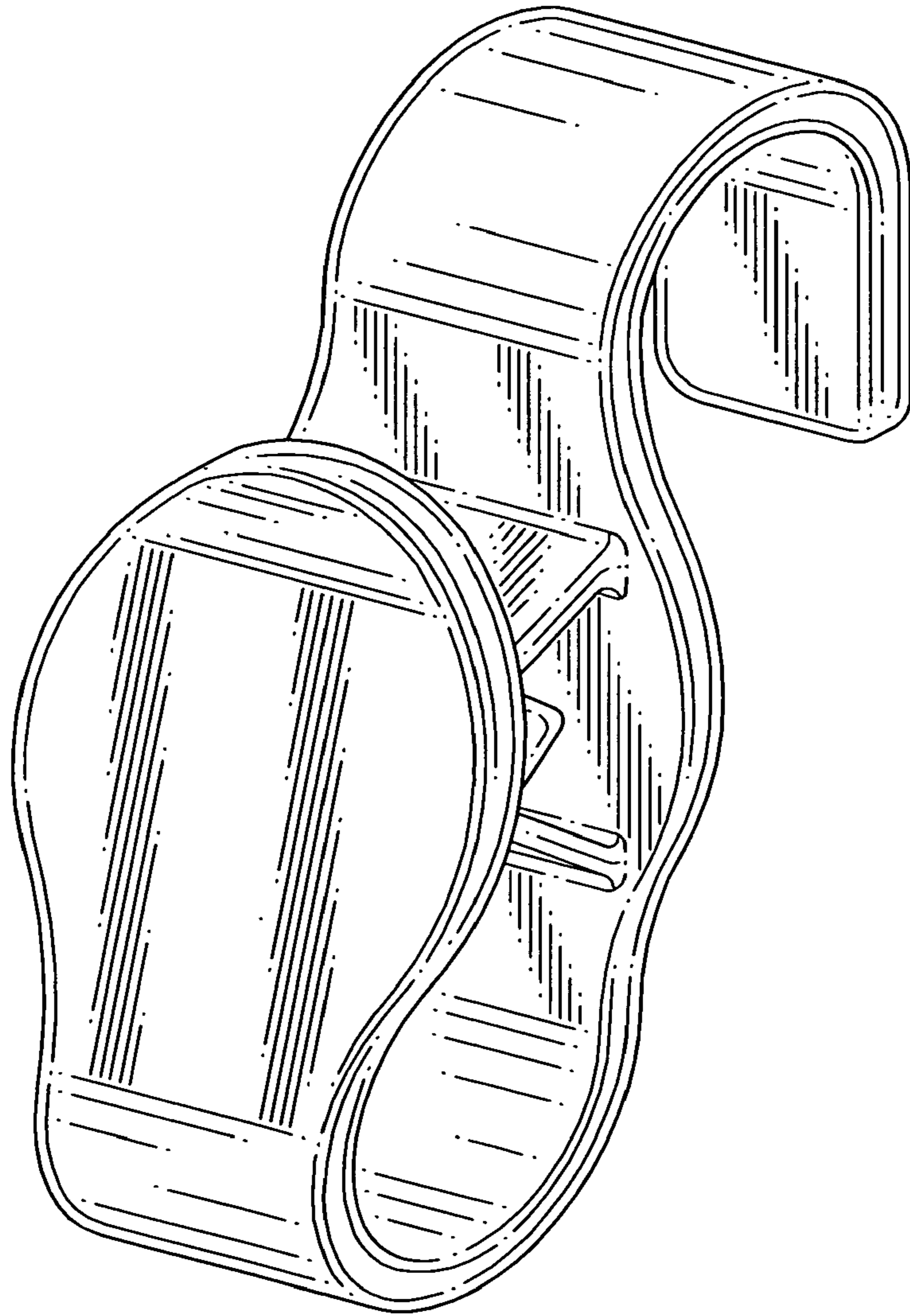

FIG. 1

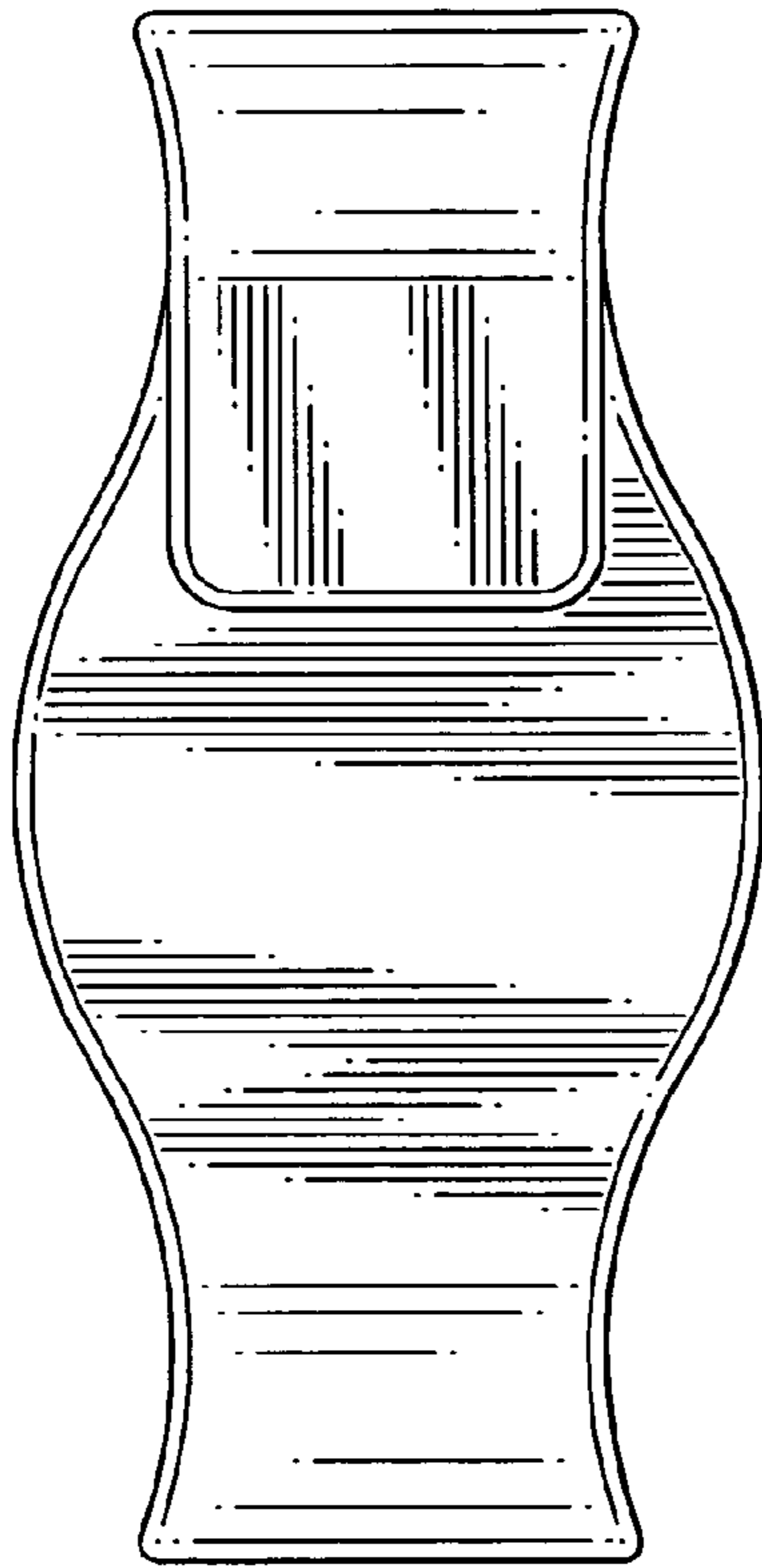

FIG. 2

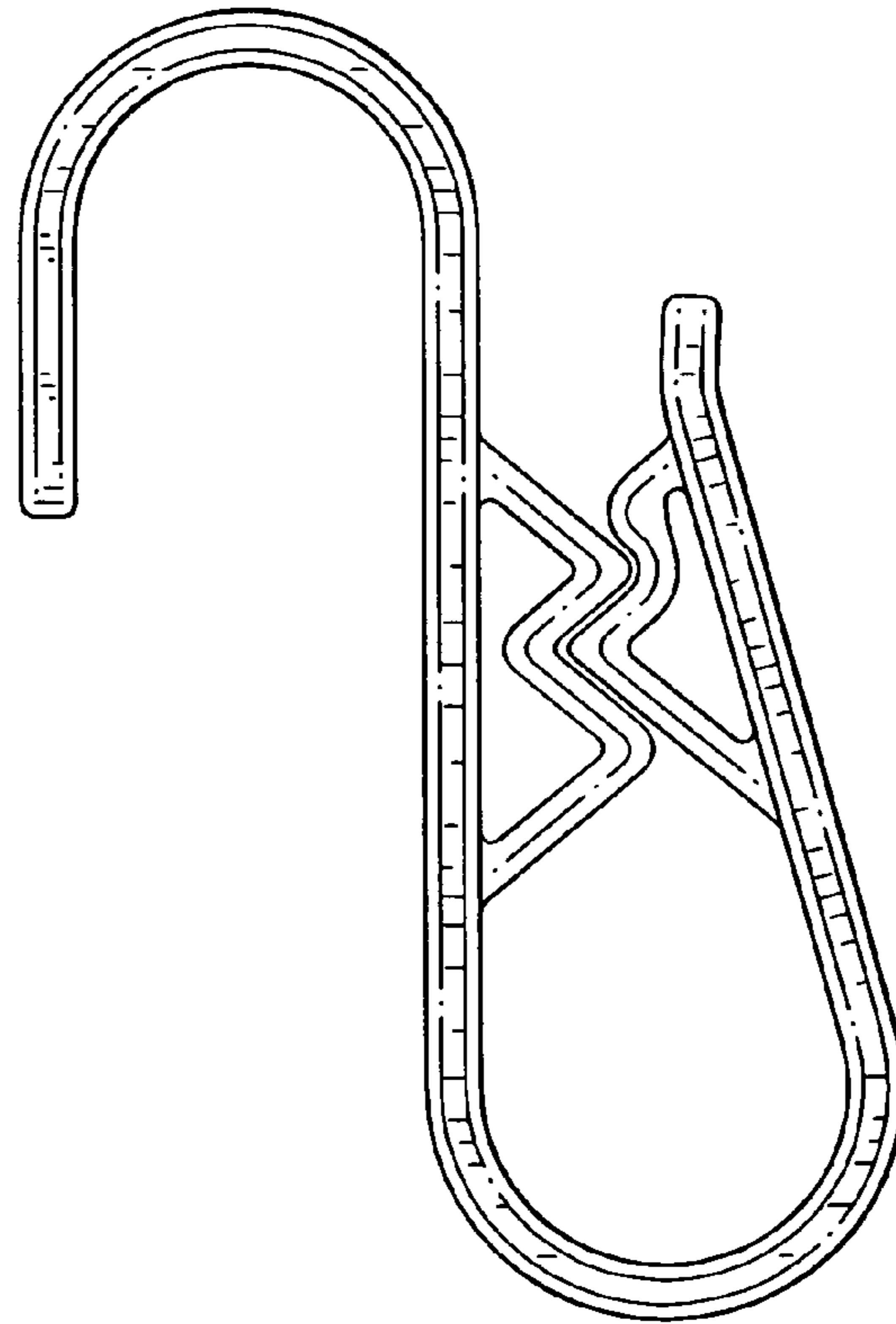

FIG. 3

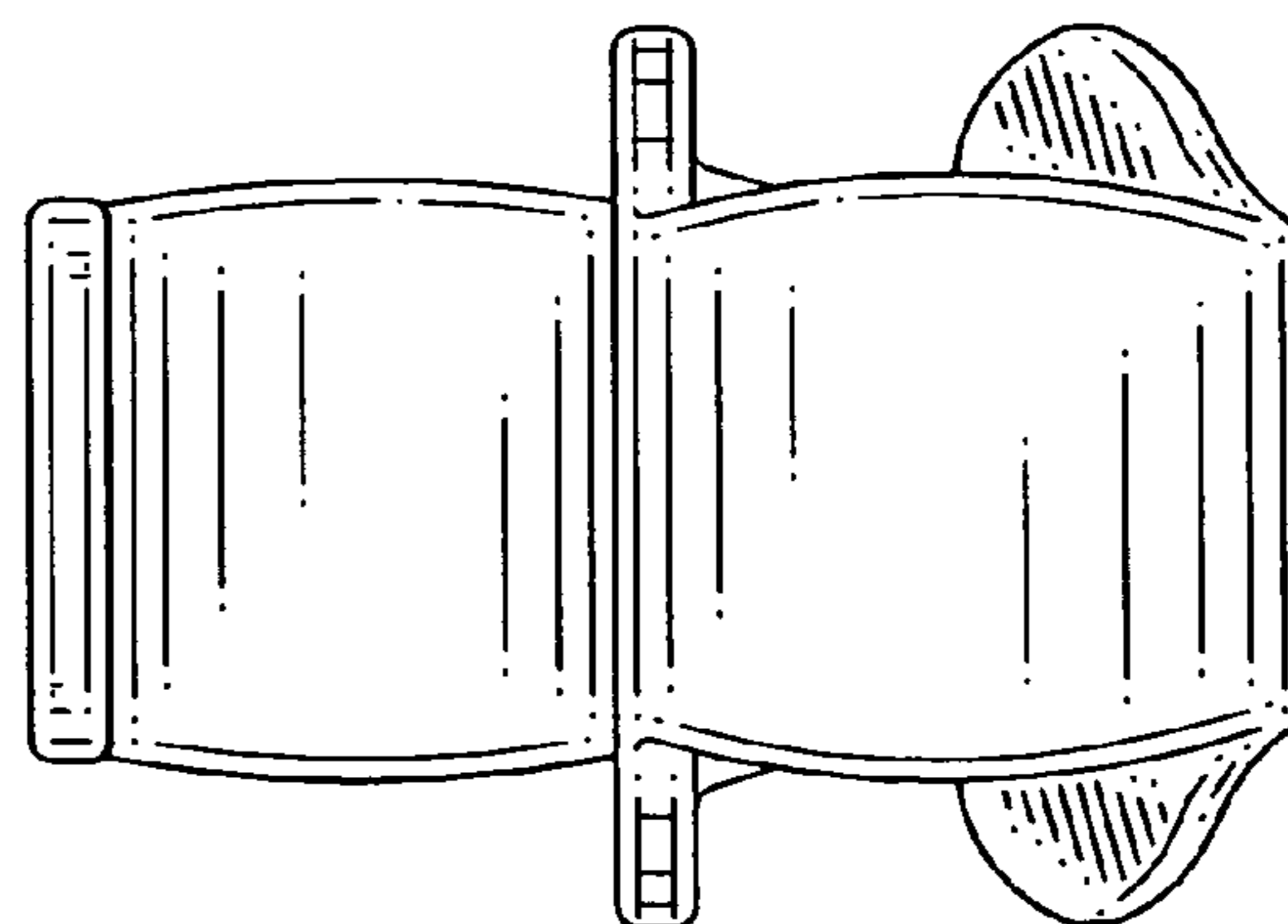

FIG. 4

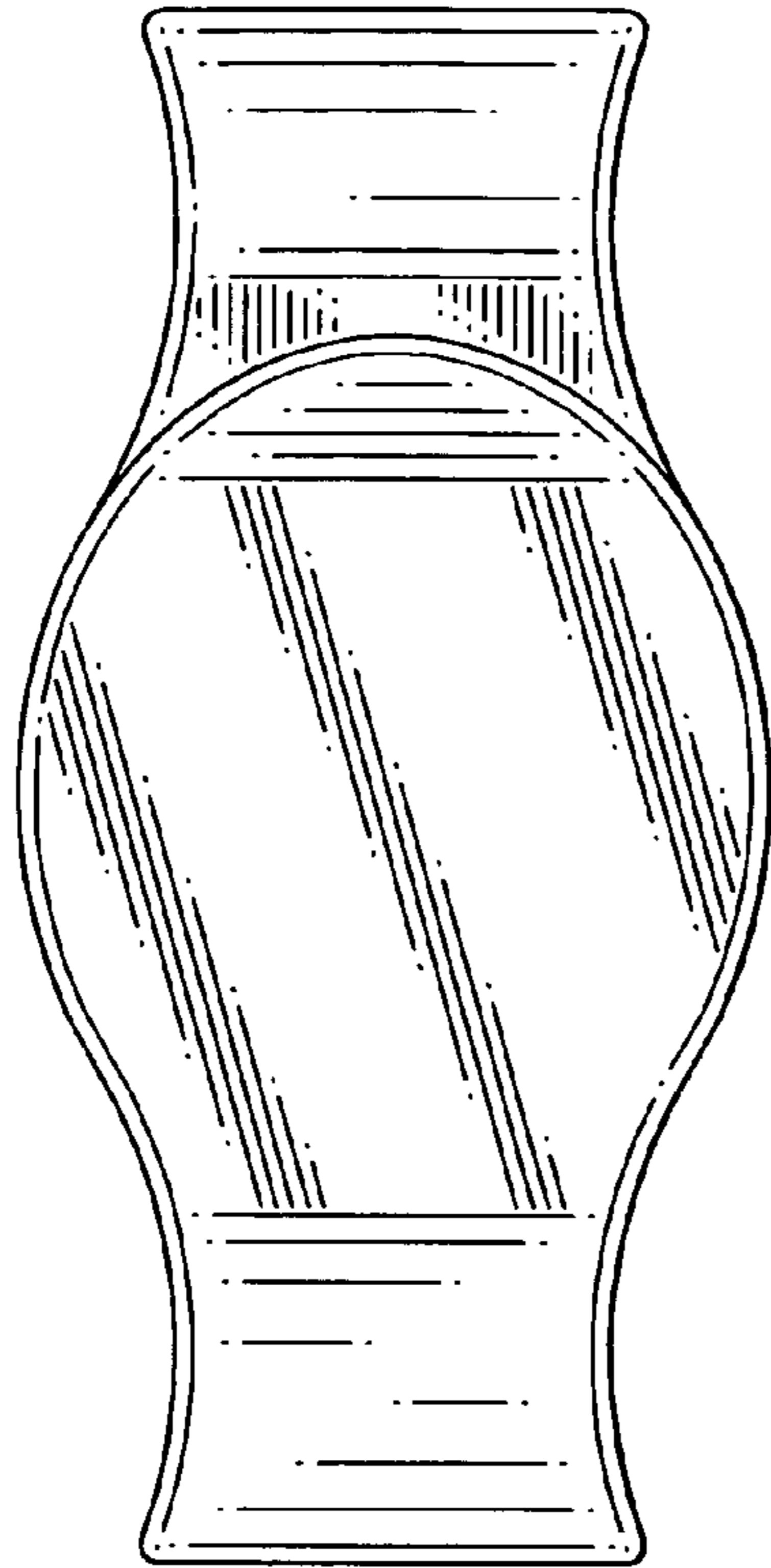

FIG. 5

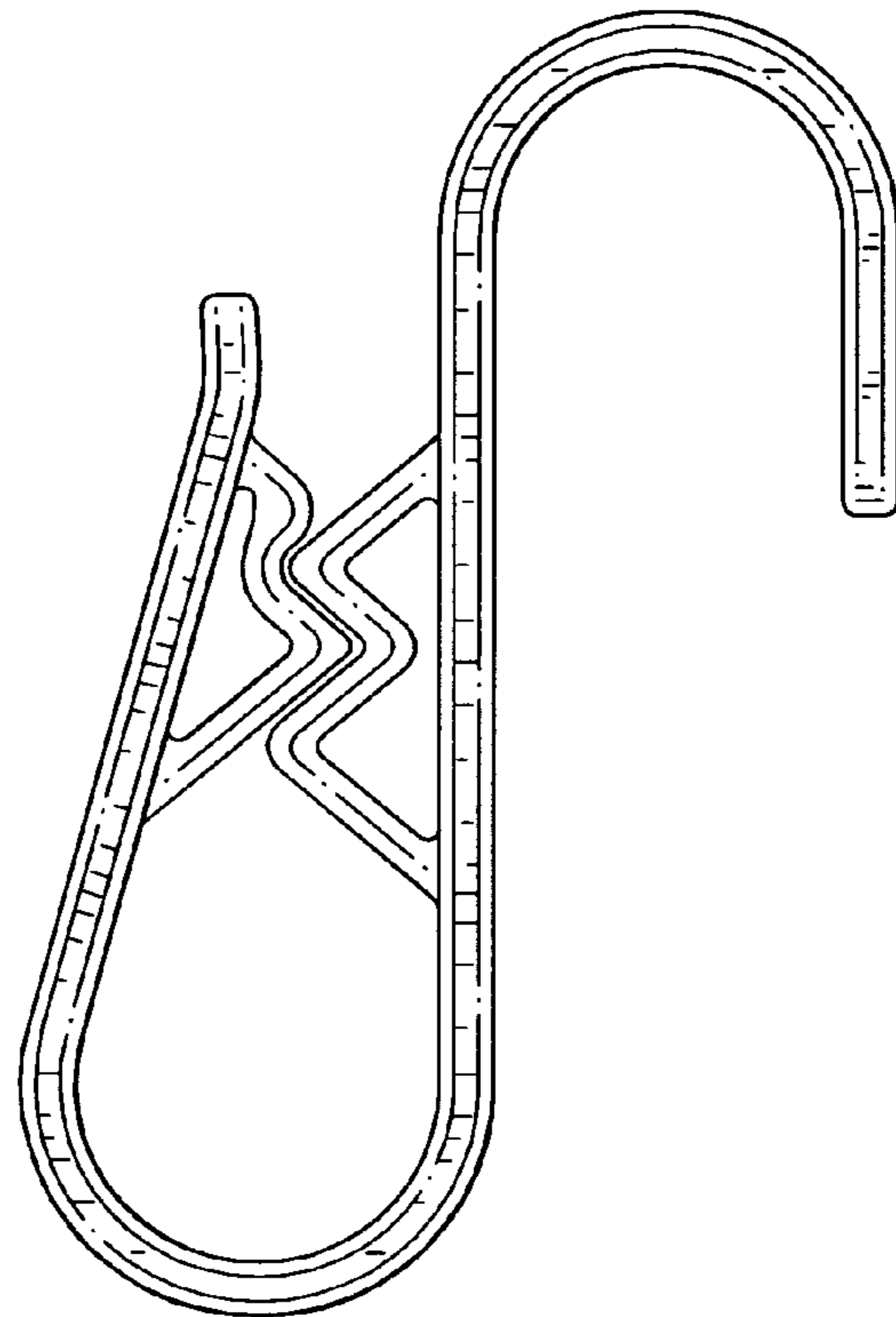

FIG. 6

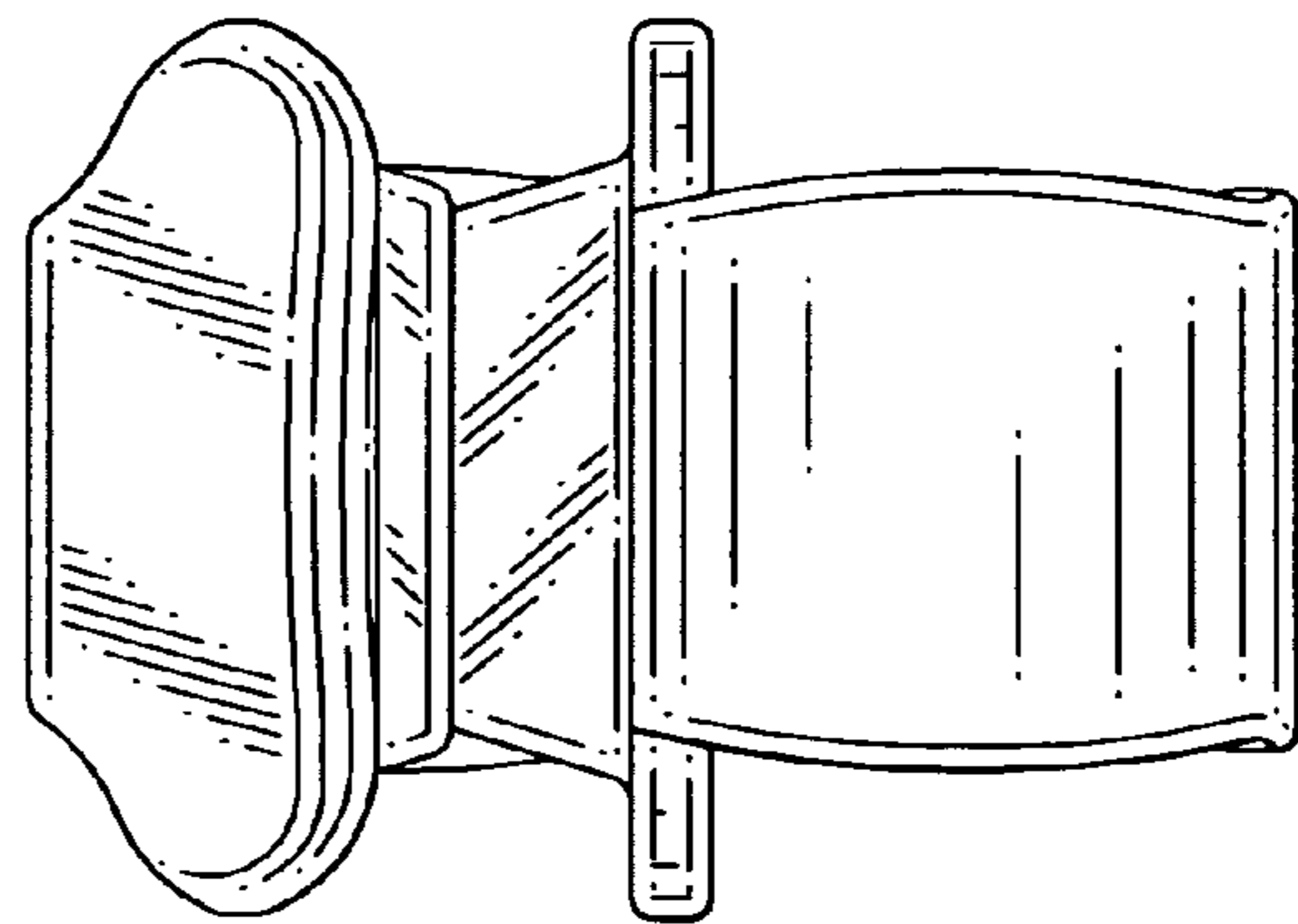

FIG. 7