



US00D618468S

(12) **United States Design Patent**  
**Bock**

(10) **Patent No.:** **US D618,468 S**  
(45) **Date of Patent:** **\*\* Jun. 29, 2010**

(54) **SET OF SEATS FOR A COMMERCIAL AIRCRAFT PASSENGER CABIN**

(75) Inventor: **Thomas-Mathias Bock**, Grenade sur Garonne (FR)

(73) Assignee: **Airbus SAS**, Blagnac Cedex (FR)

(\*\*) Term: **14 Years**

(21) Appl. No.: **29/250,826**

(22) Filed: **Dec. 1, 2006**

(51) **LOC (9) Cl.** ..... **06-01**

(52) **U.S. Cl.** ..... **D6/356**

(58) **Field of Classification Search** ..... D6/334–336, D6/364–365, 374–375, 356, 367, 379, 500–502; D12/195, 345; 297/452.21, 452.29, 452.35, 297/452.38, 284.4; 244/118.5, 118.6  
See application file for complete search history.

(56) **References Cited**

**U.S. PATENT DOCUMENTS**

D153,875 S *	5/1949	Hager	.....	D6/356
D281,471 S *	11/1985	Sauter	.....	D6/356
D281,472 S *	11/1985	Soederberg	.....	D6/356
D357,363 S *	4/1995	Frankhouse et al.	.....	D6/356
D409,010 S *	5/1999	Papaioannou et al.	.....	D6/356
D439,425 S *	3/2001	Park et al.	.....	D6/356
D443,990 S *	6/2001	Berth	.....	D6/356
D487,981 S *	4/2004	Ludeke et al.	.....	D6/356
D488,629 S *	4/2004	Giasson	.....	D6/356
D510,816 S *	10/2005	Lee	.....	D6/356
D541,541 S *	5/2007	Begin et al.	.....	D6/356

**OTHER PUBLICATIONS**

U.S. Appl. No. 29/250,809. Title: Partition for a Commercial Aircraft Passenger Cabin, filed Dec. 1, 2006.

U.S. Appl. No. 29/250,814. Title: Partition for a Commercial Aircraft Passenger Cabin, filed Dec. 1, 2006.

(Continued)

*Primary Examiner*—Caron Veynar

*Assistant Examiner*—Abraham Bahta

(74) *Attorney, Agent, or Firm*—Osler, Hoskin & Harcourt LLP

(57) **CLAIM**

The ornamental design for a set of seats for a commercial aircraft passenger cabin, as shown and described.

**DESCRIPTION**

FIG. 1 is a front-left side perspective view of a set of seats for a commercial aircraft passenger cabin according to a first embodiment of my design;

FIG. 2 is a top plan view thereof;

FIG. 3 is a front-right side perspective view of a second embodiment being a mirror image of the set of seats shown in FIG. 1;

FIG. 4 is a top plan view of the set of seats shown in FIG. 3;

FIG. 5 is a front-left side perspective view of the set of seats of FIG. 1 shown in a commercial aircraft passenger cabin; and,

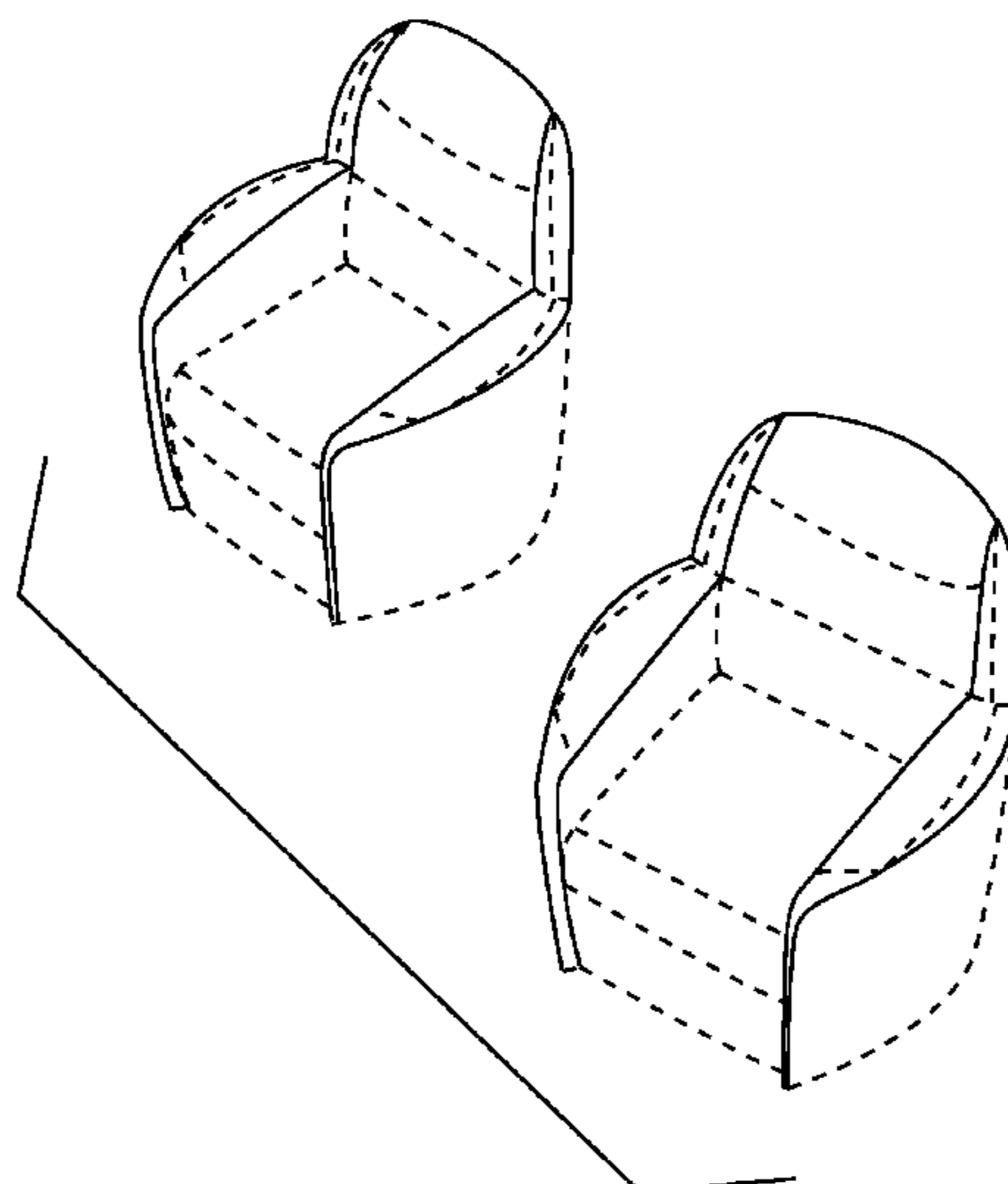
FIG. 6 is a top plan view of the set of seats and cabin shown in FIG. 5.

Bottom plan, rear, left side and right side elevation views are not part of the claimed design.

Throughout the Figures, the broken lines showing environment or structure are for illustrative purposes only and form no part of the claimed design.

As shown in the Figures, the seat layout (the positioning of each with respect to the other) is within the scope of the claimed design.

**1 Claim, 6 Drawing Sheets**



OTHER PUBLICATIONS

U.S. Appl. No. 29/250,818. Title: Partition for a Commercial Aircraft Passenger Cabin, filed Dec. 1, 2006.

U.S. Appl. No. 29/250,828. Title: Partition for a Commercial Aircraft Passenger Cabin, filed Dec. 1, 2006.

U.S. Appl. No. 29/250,831. Title: Seat Body for a Commercial Aircraft Passenger Cabin, filed Dec. 1, 2006.

U.S. Appl. No. 29/250,825. Title: Partition Layout for a Commercial Aircraft Passenger Cabin, filed Dec. 1, 2006.

U.S. Appl. No. 29/250,833. Title: Partition Layout for a Commercial Aircraft Passenger Cabin, filed Dec. 1, 2006.

U.S. Appl. No. 29/250,834. Title: Partition Layout for a Commercial Aircraft Passenger Cabin, filed Dec. 1, 2006.

U.S. Appl. No. 29/250,832. Title: Ottoman for a Commercial Aircraft Passenger Cabin, filed Dec. 1, 2006.

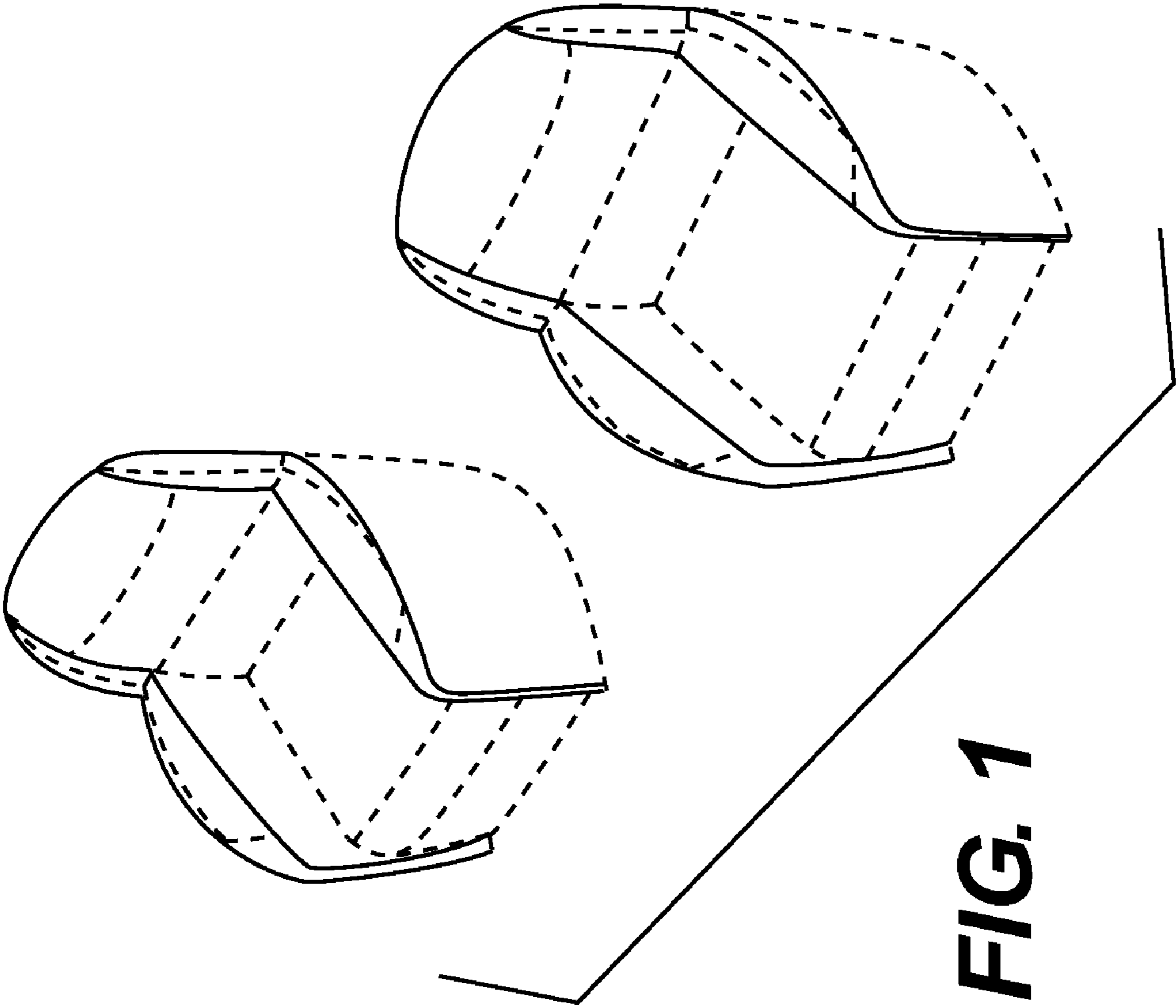
U.S. Appl. No. 29/250,811. Title: Seat for a Commercial Aircraft Passenger Cabin, filed Dec. 1, 2006.

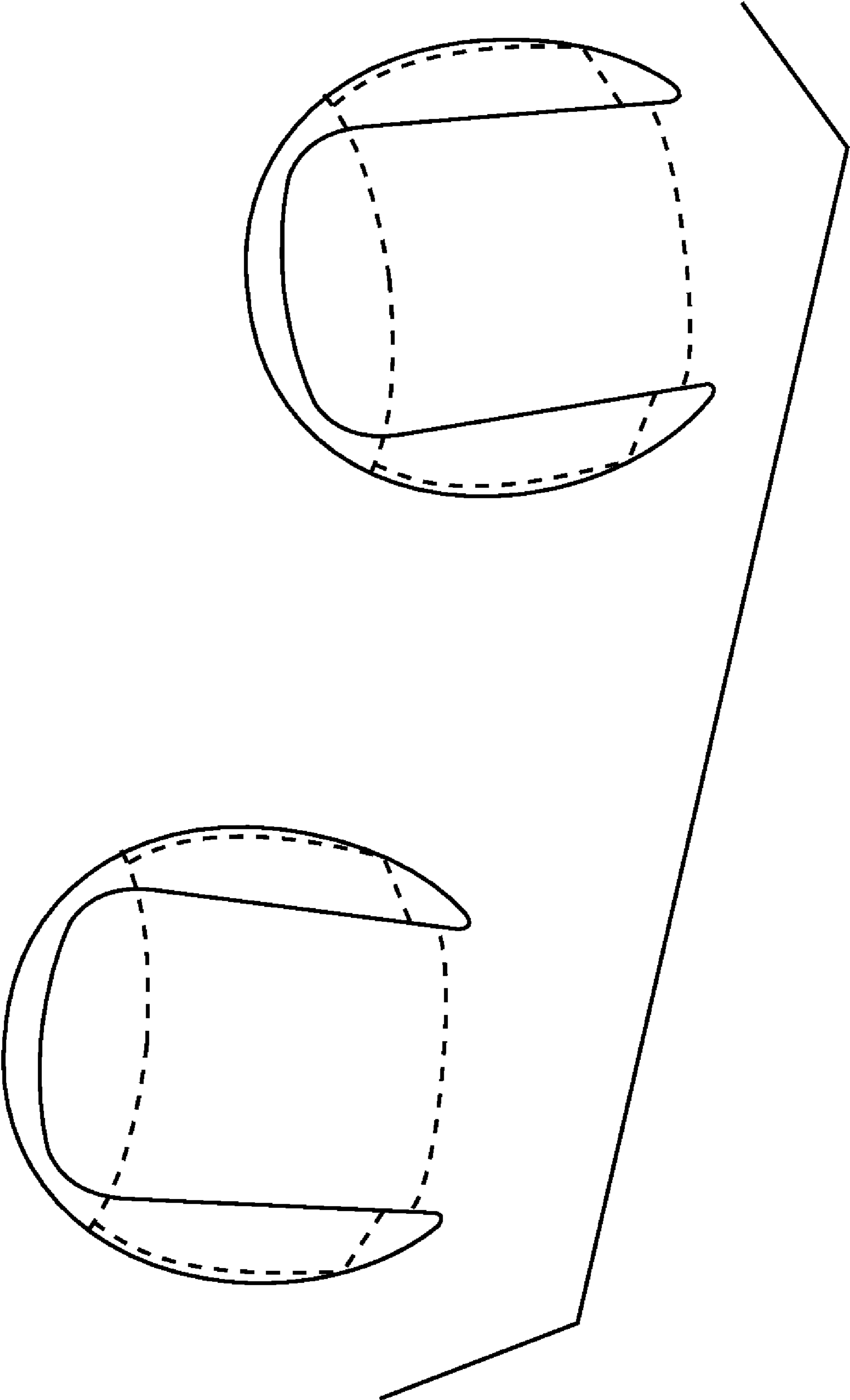
U.S. Appl. No. 29/250,810. Title: Furniture for a Commercial Aircraft Passenger Cabin, filed Dec. 1, 2006.

U.S. Appl. No. 29/250,829. Title: Furniture for a Commercial Aircraft Passenger Cabin, filed Dec. 1, 2006.

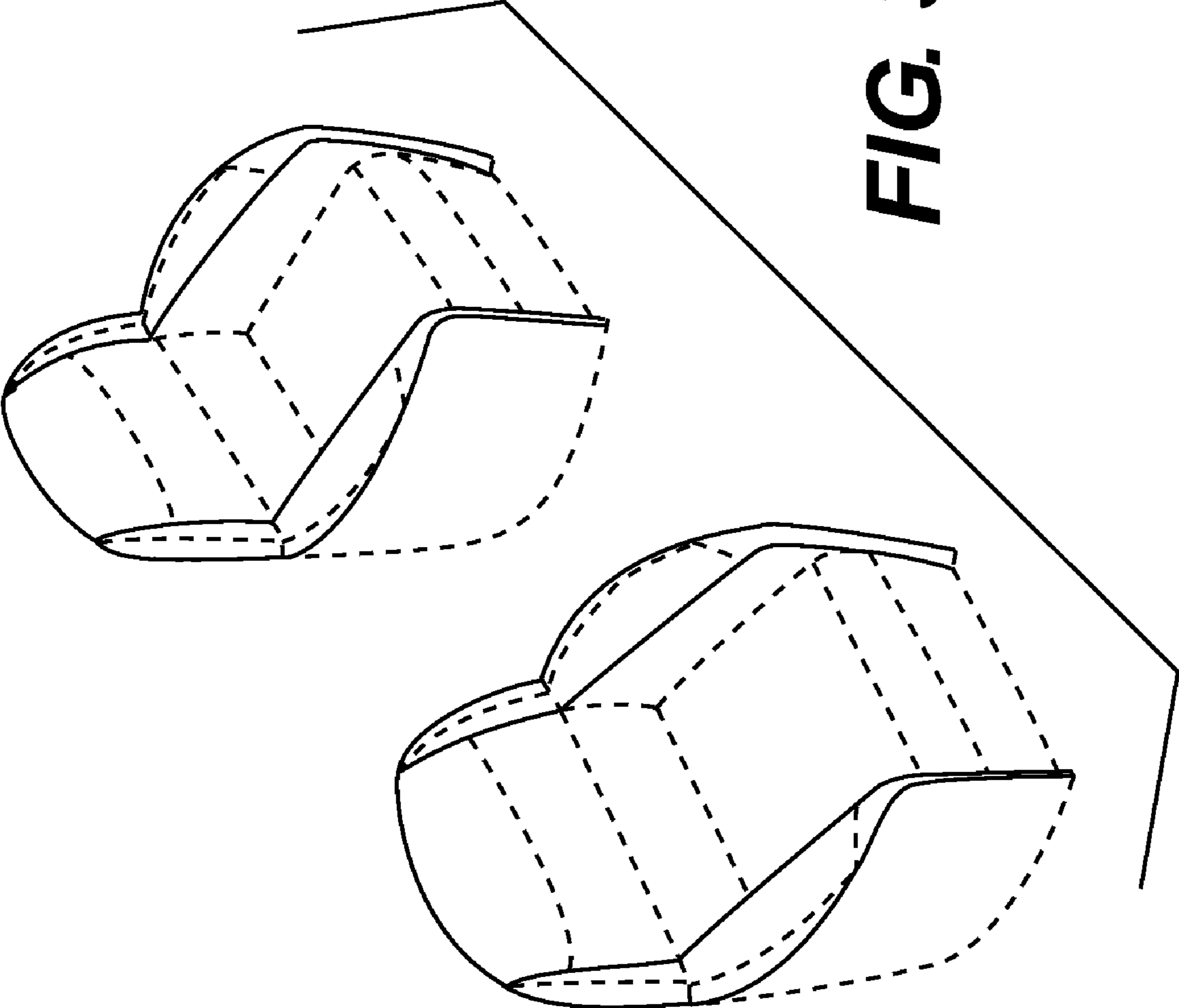
U.S. Appl. No. 29/250,813. Title: Armrest/Backrest Combination for an Ottoman for a Commercial Aircraft Passenger Cabin, filed Dec. 1, 2006.

\* cited by examiner

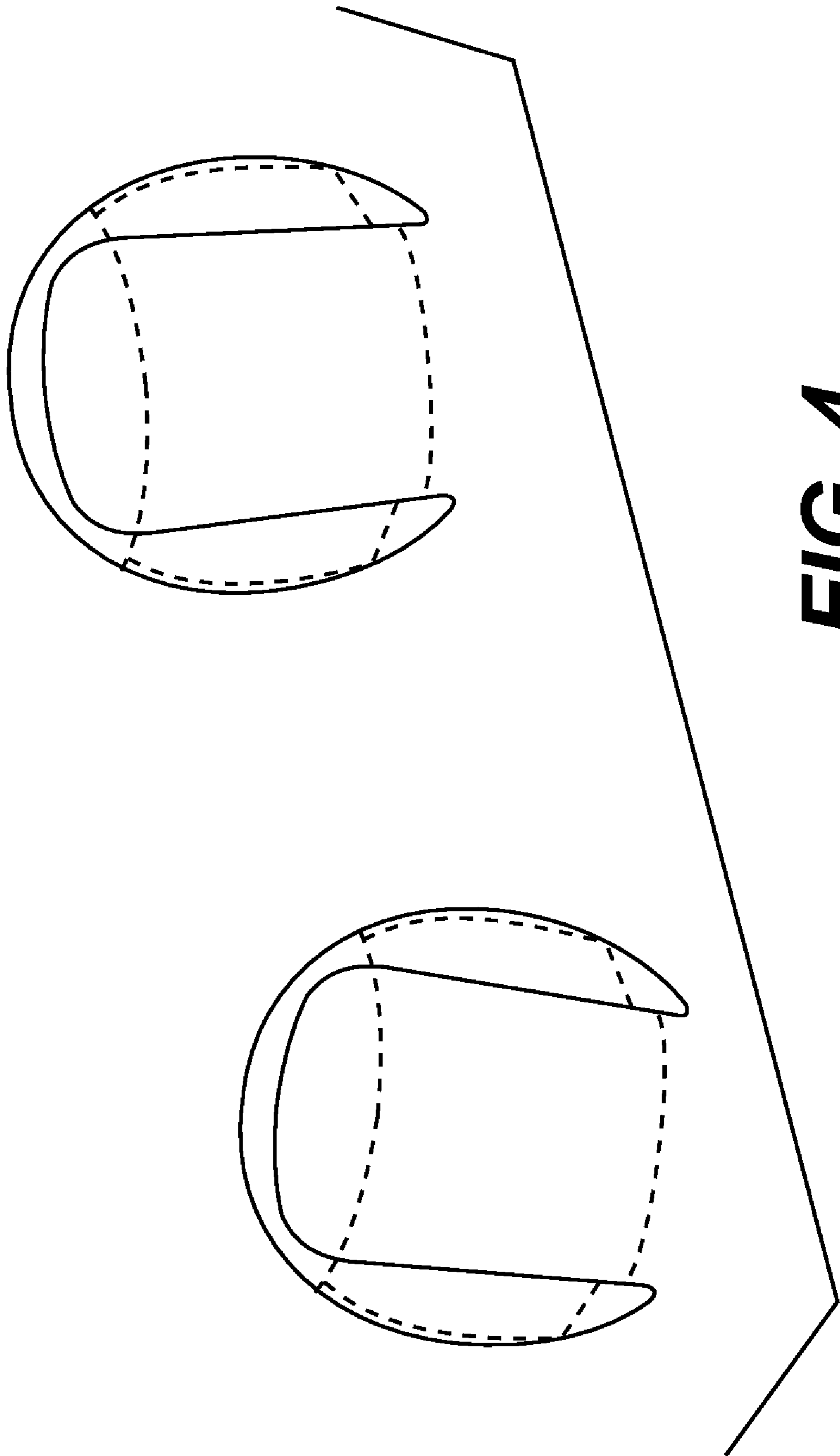




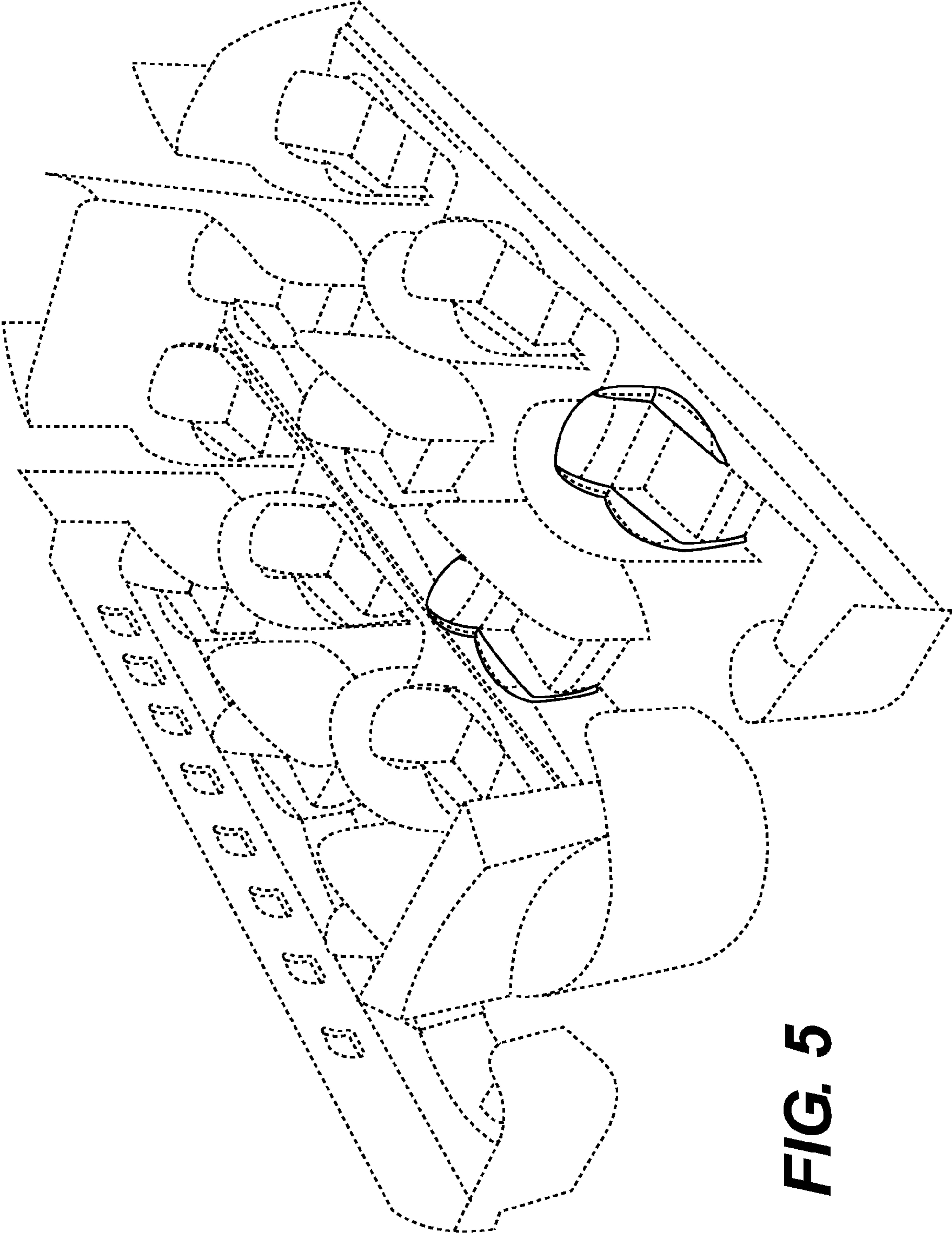
**FIG. 2**



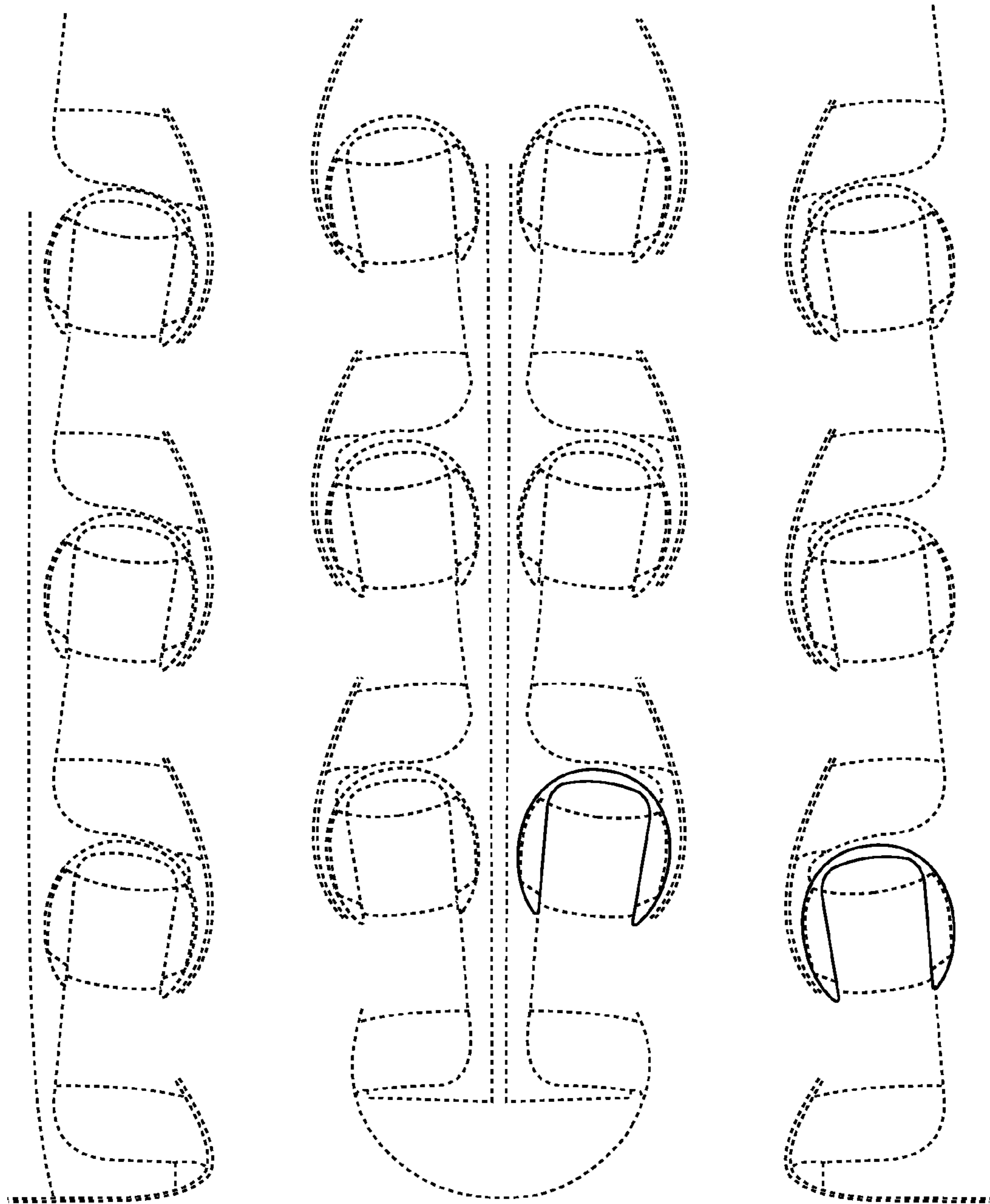
**FIG. 3**



**FIG. 4**



**FIG. 5**



**FIG. 6**