



US00D618181S

(12) **United States Design Patent**
Gross et al.

(10) **Patent No.:** **US D618,181 S**
(45) **Date of Patent:** **** Jun. 22, 2010**

(54) **ASYMMETRICAL ELECTRICAL CONNECTOR**

(75) Inventors: **Charles M. Gross**, York, PA (US); **John David Dodds**, Harrisburg, PA (US)

(73) Assignee: **FCI Americas Technology, Inc.**, Carson City, NV (US)

(**) Term: **14 Years**

(21) Appl. No.: **29/334,906**

(22) Filed: **Apr. 3, 2009**

(51) **LOC (9) Cl.** **13-03**

(52) **U.S. Cl.** **D13/154**

(58) **Field of Classification Search** D13/133,
D13/146–147, 153, 154, 184; 439/606–610,
439/655, 660, 678, 682, 686, 692, 696

See application file for complete search history.

(56) **References Cited**

U.S. PATENT DOCUMENTS

318,186 A	5/1885	Hertzog	
1,477,527 A	12/1923	Raettig	
D86,515 S *	3/1932	Cox	D13/147
2,248,675 A	7/1941	Huppert	
2,430,011 A	11/1947	Gillentine	
2,759,163 A	8/1956	Ustin et al.	
2,762,022 A	9/1956	Benander et al.	
2,844,644 A	7/1958	Soule, Jr.	
3,011,143 A	11/1961	Dean	

(Continued)

FOREIGN PATENT DOCUMENTS

DE 1 665 181 4/1974

(Continued)

OTHER PUBLICATIONS

U.S. Appl. No. 12/317,366, filed Dec. 22, 2008, Minich.

(Continued)

Primary Examiner—Daniel D Bui

(74) *Attorney, Agent, or Firm*—Woodcock Washburn LLP

(57) **CLAIM**

The ornamental design for an asymmetrical electrical connector, as shown and described.

DESCRIPTION

This application is related by subject matter to U.S. patent application Ser. No. 29/334,904 entitled “Electrical Connector” filed on even date herewith.

FIG. 1 is a top, left, rear perspective view of an asymmetrical electrical connector according to our design;

FIG. 2 is a rear elevation view thereof;

FIG. 3 is a top plan view thereof;

FIG. 4 is a right side elevation view thereof;

FIG. 5 is a bottom plan view thereof;

FIG. 6 is a left side elevation view thereof; and,

FIG. 7 is a front elevation view thereof.

The broken line in the figure drawings is included to show the environment of unclaimed subject matter only and forms no part of the claimed design. The dash-dot line represents the boundary of the claimed design.

In a preferred embodiment, the nature of this product is an electrical connector in the form of an electrical connector housing configured for retaining a plurality of electrical contacts.

1 Claim, 7 Drawing Sheets

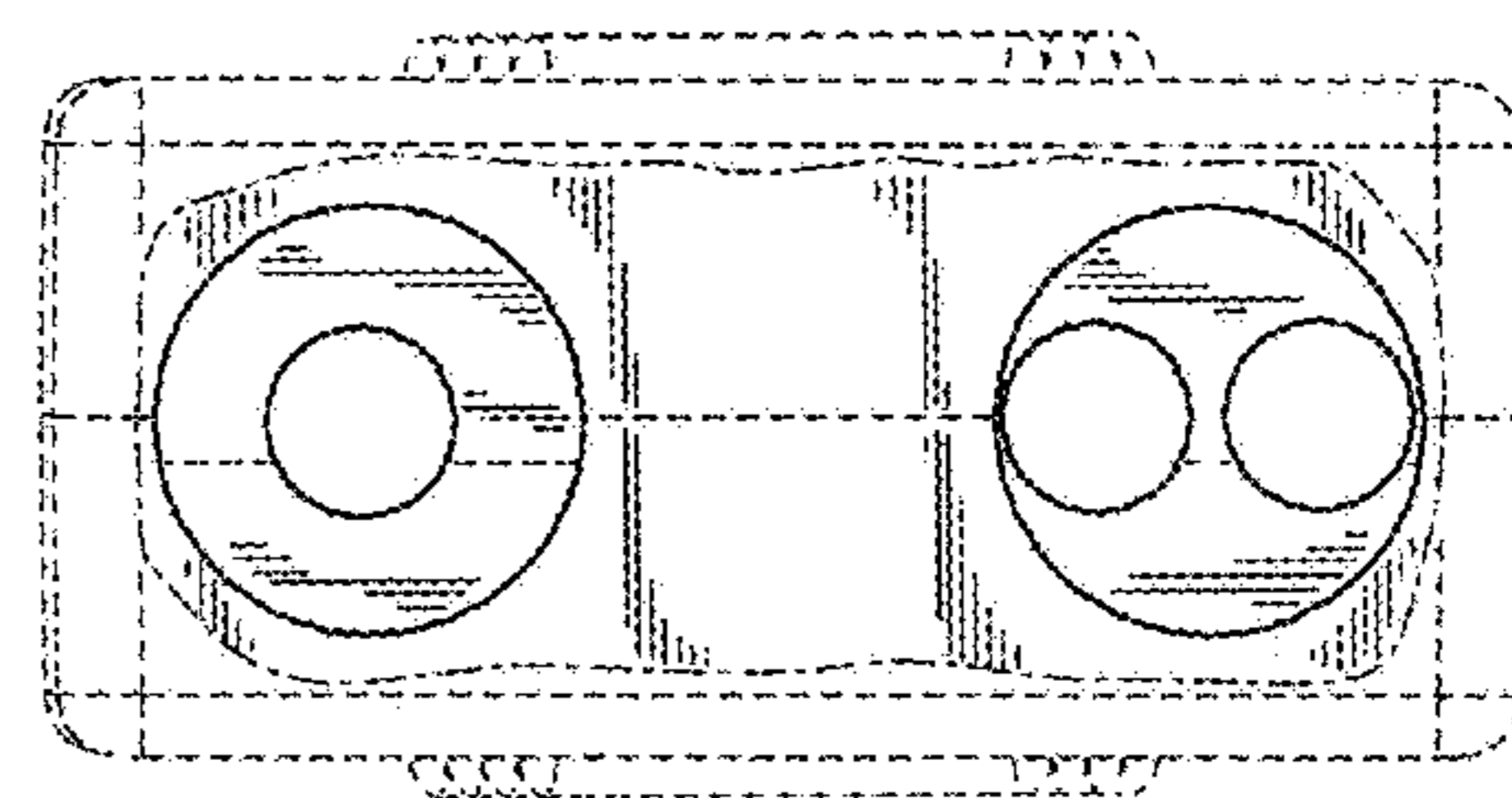
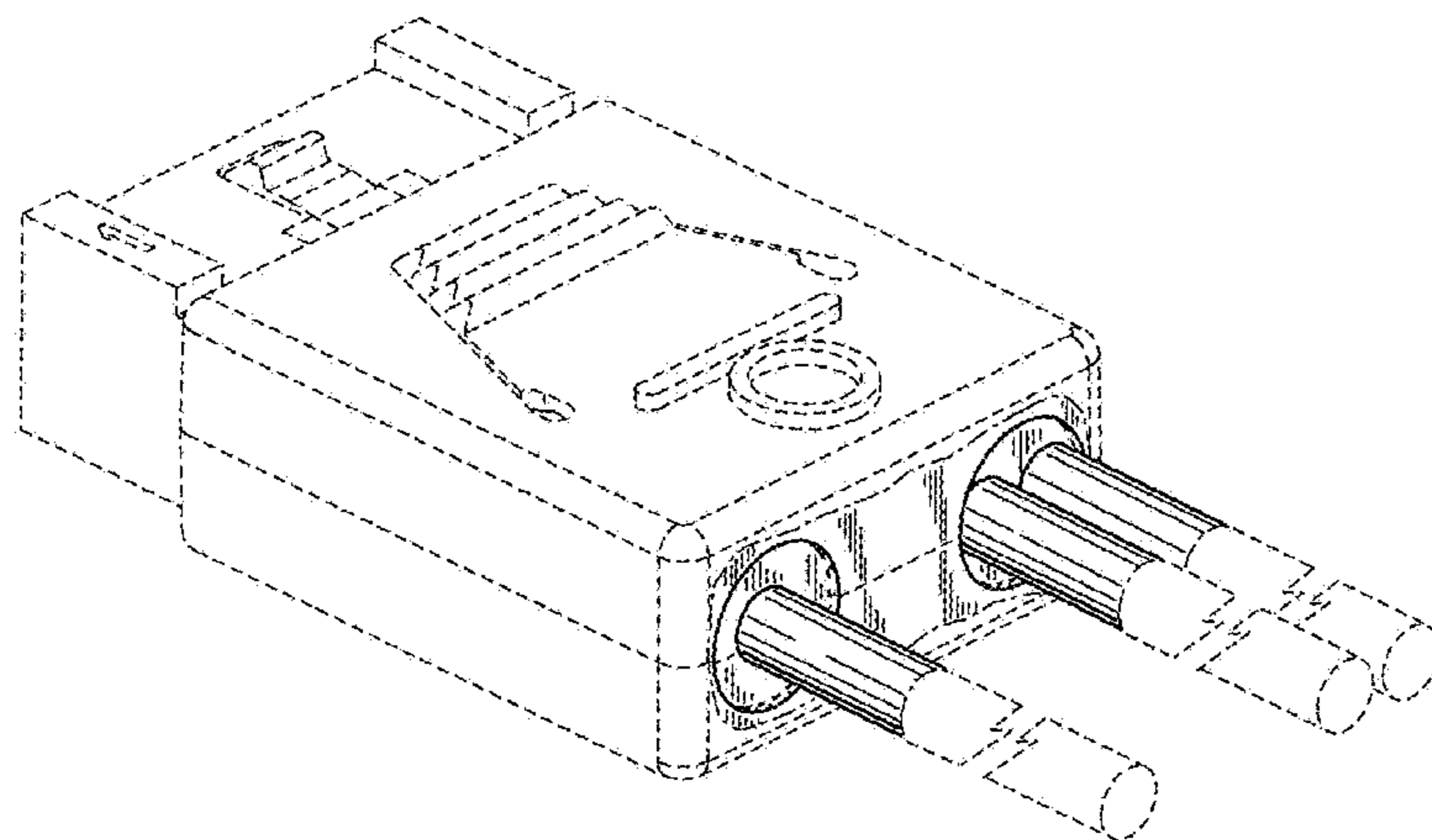

US D618,181 S

Page 2

U.S. PATENT DOCUMENTS					
			5,151,056 A	9/1992	McClune
			5,152,700 A	10/1992	Bogursky et al.
			5,174,770 A	12/1992	Sasaki et al.
			5,194,480 A	3/1993	Block et al.
			5,213,868 A	5/1993	Liberty et al.
			5,214,308 A	5/1993	Nishiguchi et al.
			5,238,414 A	8/1993	Yaegashi et al.
			5,254,012 A	10/1993	Wang
			5,274,918 A	1/1994	Reed
			5,276,964 A	1/1994	Anderson, Jr. et al.
			5,285,163 A *	2/1994	Liotta 324/508
			5,286,212 A	2/1994	Broeksteeg
			5,295,843 A	3/1994	Davis et al.
			5,298,791 A	3/1994	Liberty et al.
			5,302,135 A	4/1994	Lee
			5,321,582 A	6/1994	Casperson
			5,381,314 A	1/1995	Rudy, Jr. et al.
			D355,409 S *	2/1995	Krokaugger D13/146
			5,400,949 A	3/1995	Hirvonen et al.
			5,427,543 A	6/1995	Dynia
			5,431,578 A	7/1995	Wayne
			5,457,342 A	10/1995	Herbst, II
			5,458,426 A	10/1995	Ito
			5,475,922 A	12/1995	Tamura et al.
			5,490,040 A	2/1996	Gaudenzi et al.
			5,511,987 A	4/1996	Shinchi
			5,512,519 A	4/1996	Hwang
			5,533,915 A	7/1996	Deans
			5,558,542 A	9/1996	O'Sullivan et al.
			5,564,952 A	10/1996	Davis et al.
			5,577,928 A	11/1996	Duclos
			5,588,859 A	12/1996	Maurice
			5,590,463 A	1/1997	Feldman et al.
			5,609,502 A	3/1997	Thumma
			5,618,187 A	4/1997	Goto
			5,637,008 A	6/1997	Kozel
			5,643,009 A	7/1997	Dinkel et al.
			5,664,968 A	9/1997	Mickiewicz
			5,664,973 A	9/1997	Emmert et al.
			5,667,392 A	9/1997	Kocher et al.
			5,691,041 A	11/1997	Frankeny et al.
			5,702,255 A	12/1997	Murphy et al.
			5,727,963 A	3/1998	LeMaster
			5,730,609 A	3/1998	Harwath
			5,741,144 A	4/1998	Elco et al.
			5,741,161 A	4/1998	Cahaly et al.
			5,742,484 A	4/1998	Gillette et al.
			5,743,009 A	4/1998	Matsui et al.
			5,745,349 A	4/1998	Lemke
			5,746,608 A	5/1998	Taylor
			5,749,746 A	5/1998	Tan et al.
			5,755,595 A	5/1998	Davis et al.
			5,772,451 A	6/1998	Dozier, II et al.
			5,782,644 A	7/1998	Kiat
			5,787,971 A	8/1998	Dodson
			5,795,191 A	8/1998	Preputnick et al.
			5,810,607 A	9/1998	Shih et al.
			5,817,973 A	10/1998	Elco et al.
			5,827,094 A	10/1998	Aizawa et al.
			5,831,314 A	11/1998	Wen
			5,857,857 A	1/1999	Fukuda
			5,874,776 A	2/1999	Kresge et al.
			5,876,219 A	3/1999	Taylor
			5,876,248 A	3/1999	Brunker et al.
			5,882,214 A	3/1999	Hillbish et al.
			5,883,782 A	3/1999	Thurston et al.
			5,888,884 A	3/1999	Wojnarowski
			5,908,333 A	6/1999	Perino et al.
			5,919,050 A	7/1999	Kehley et al.
			5,930,114 A	7/1999	Kuzmin et al.
			5,955,888 A	9/1999	Frederickson et al.
			5,961,355 A	10/1999	Morlion et al.
			5,971,817 A	10/1999	Longueville

US D618,181 S

5,975,921 A	11/1999	Shuey	6,471,548 B2	10/2002	Bertoncini et al.
5,980,270 A	11/1999	Fjelstad et al.	6,472,474 B2	10/2002	Burkhardt et al.
5,980,321 A	11/1999	Cohen et al.	6,488,549 B1	12/2002	Weller et al.
5,984,726 A	11/1999	Wu	6,489,567 B2	12/2002	Zachrai
5,993,259 A	11/1999	Stokoe et al.	6,506,081 B2	1/2003	Blanchfield et al.
6,012,948 A	1/2000	Wu	6,514,103 B2	2/2003	Pape et al.
6,036,549 A	3/2000	Wulff	6,537,111 B2	3/2003	Brammer et al.
6,041,498 A	3/2000	Hillbish et al.	6,544,046 B1	4/2003	Hahn et al.
6,050,862 A	4/2000	Ishii	6,551,112 B1	4/2003	Li et al.
6,059,170 A	5/2000	Jimarez et al.	6,554,647 B1	4/2003	Cohen et al.
6,066,048 A	5/2000	Lees	6,572,410 B1	6/2003	Volstorf et al.
6,068,520 A	5/2000	Winings et al.	6,575,774 B2	6/2003	Ling et al.
6,071,152 A	6/2000	Achammer et al.	6,575,776 B1	6/2003	Conner et al.
6,077,130 A	6/2000	Hughes et al.	6,592,381 B2	7/2003	Cohen et al.
6,089,878 A	7/2000	Meng	6,604,967 B2	8/2003	Middlehurst et al.
6,095,827 A	8/2000	Dutkowsky et al.	741,052 A1	10/2003	Mahon
6,123,554 A	9/2000	Ortega et al.	6,629,854 B2	10/2003	Murakami
6,125,535 A	10/2000	Chiou et al.	6,652,318 B1	11/2003	Winings et al.
6,139,336 A	10/2000	Olson	6,663,426 B2	12/2003	Hasircoglu et al.
6,146,157 A	11/2000	Lenoir et al.	6,665,189 B1	12/2003	Lebo
6,146,202 A	11/2000	Ramey et al.	6,669,514 B2	12/2003	Wiebking et al.
6,146,203 A	11/2000	Elco et al.	6,672,884 B1	1/2004	Lim et al.
6,152,756 A	11/2000	Huang et al.	6,672,907 B2	1/2004	Azuma
6,174,198 B1	1/2001	Wu et al.	6,679,709 B2	1/2004	Takeuchi
6,180,891 B1	1/2001	Murdeshwar	6,692,272 B2	2/2004	Lemke et al.
6,183,287 B1	2/2001	Po	6,702,594 B2	3/2004	Lee et al.
6,183,301 B1	2/2001	Paagman	6,705,902 B1	3/2004	Yi et al.
6,190,213 B1	2/2001	Reichart et al.	6,712,621 B2	3/2004	Li et al.
6,193,537 B1	2/2001	Harper, Jr. et al.	6,716,068 B2	4/2004	Wu
6,196,871 B1	3/2001	Szu	6,740,820 B2	5/2004	Cheng
6,202,916 B1	3/2001	Updike et al.	D492,295 S *	6/2004	Glatt D14/240
6,206,722 B1	3/2001	Ko et al.	6,743,037 B2	6/2004	Kassa et al.
6,210,197 B1	4/2001	Yu	6,746,278 B2	6/2004	Nelson et al.
6,210,240 B1	4/2001	Comerci et al.	6,769,883 B2	8/2004	Brid et al.
6,212,755 B1	4/2001	Shimada et al.	6,769,935 B2	8/2004	Stokoe et al.
6,215,180 B1	4/2001	Chen et al.	6,776,635 B2	8/2004	Blanchfield et al.
6,219,913 B1	4/2001	Uchiyama	6,776,649 B2	8/2004	Pape et al.
6,220,884 B1	4/2001	Lin	6,780,027 B2	8/2004	Allison et al.
6,220,895 B1	4/2001	Lin	6,790,088 B2	9/2004	Ono et al.
6,220,896 B1	4/2001	Bertoncini et al.	6,796,831 B1	9/2004	Yasufuku et al.
6,234,851 B1	5/2001	Phillips	6,810,783 B1	11/2004	Larose
6,238,225 B1	5/2001	Middlehurst et al.	6,811,440 B1	11/2004	Rothermel et al.
6,257,478 B1	7/2001	Straub	6,814,590 B2	11/2004	Minich et al.
6,259,039 B1	7/2001	Chroneos, Jr. et al.	6,829,143 B2	12/2004	Russell et al.
6,261,132 B1	7/2001	Koseki et al.	6,835,103 B2	12/2004	Middlehurst et al.
6,269,539 B1	8/2001	Takahashi et al.	6,843,687 B2	1/2005	McGowan et al.
6,274,474 B1	8/2001	Caletka et al.	6,848,886 B2	2/2005	Schmaling et al.
6,280,230 B1	8/2001	Takase et al.	6,848,950 B2	2/2005	Allison et al.
6,293,827 B1	9/2001	Stokoe et al.	6,848,953 B2	2/2005	Schell et al.
6,299,492 B1	10/2001	Pierini et al.	D502,919 S *	3/2005	Studnicky, III D13/146
6,309,245 B1	10/2001	Sweeney	6,869,294 B2	3/2005	Clark et al.
6,319,075 B1	11/2001	Clark et al.	6,884,117 B2	4/2005	Korsunsky et al.
6,322,377 B2	11/2001	Middlehurst et al.	6,890,221 B2	5/2005	Wagner
6,328,602 B1	12/2001	Yamasaki et al.	6,905,367 B2	6/2005	Crane, Jr. et al.
6,347,952 B1	2/2002	Hasegawa et al.	6,929,504 B2	8/2005	Ling et al.
6,350,134 B1	2/2002	Fogg et al.	6,947,012 B2	9/2005	Aisenbrey
6,359,783 B1	3/2002	Noble	6,969,268 B2	11/2005	Brunker et al.
6,360,940 B1	3/2002	Bolde et al.	6,975,511 B1	12/2005	Lebo et al.
6,362,961 B1	3/2002	Chiou	6,994,569 B2	2/2006	Minich et al.
6,363,607 B1	4/2002	Chen et al.	7,001,189 B1	2/2006	McGowan et al.
6,371,773 B1	4/2002	Crofoot et al.	7,059,892 B1	6/2006	Trout
6,379,188 B1	4/2002	Cohen et al.	7,059,919 B2	6/2006	Clark et al.
6,386,924 B2	5/2002	Long	7,065,871 B2	6/2006	Minich et al.
6,394,818 B1	5/2002	Smalley, Jr.	7,070,464 B2	7/2006	Clark et al.
6,402,566 B1	6/2002	Middlehurst et al.	7,074,096 B2	7/2006	Copper et al.
6,409,543 B1	6/2002	Astbury, Jr. et al.	7,086,147 B2	8/2006	Caletka et al.
6,428,328 B2	8/2002	Haba et al.	7,097,465 B1	8/2006	Korsunsky et al.
6,431,914 B1	8/2002	Billman	7,101,228 B2	9/2006	Hammer et al.
6,435,914 B1	8/2002	Billman	7,104,812 B1	9/2006	Bogiel et al.
6,450,829 B1	9/2002	Weisz-Margulescu	7,114,963 B2	10/2006	Shuey et al.
6,461,183 B1	10/2002	Ohkita et al.	RE39,380 E	11/2006	Davis
6,461,202 B2	10/2002	Kline	7,137,848 B1	11/2006	Trout et al.
6,471,523 B1	10/2002	Shuey	7,168,963 B2	1/2007	Minich et al.

US D618,181 S

Page 4

7,182,642	B2	2/2007	Ngo et al.	JP	06-236788	8/1994
7,204,699	B2	4/2007	Stoner	JP	07-114958	5/1995
D542,736	S	5/2007	Riku	JP	07169523	7/1995
7,220,141	B2	5/2007	Daily et al.	JP	08096918	4/1996
7,258,562	B2	8/2007	Daily et al.	JP	0 812 5379	5/1996
D550,158	S *	9/2007	Victor D13/146	JP	9199215	7/1997
7,273,382	B2	9/2007	Igarashi et al.	JP	2000-003743	1/2000
D554,591	S *	11/2007	Victor D13/154	JP	2000-003744	1/2000
7,303,427	B2	12/2007	Swain	JP	2000-003745	1/2000
7,335,043	B2	2/2008	Ngo et al.	JP	2000-003746	1/2000
7,384,289	B2	6/2008	Minich	JP	2000-228243	8/2000
7,402,064	B2	7/2008	Daily	JP	13135388	5/2001
7,425,145	B2	9/2008	Ngo et al.	JP	2003-217785	7/2003
7,452,249	B2	11/2008	Daily	KR	100517561	9/2005
7,458,839	B2	12/2008	Ngo	TW	576555	8/1990
7,476,108	B2	5/2009	Swain et al.	TW	546872	8/2003
7,541,135	B2	6/2009	Swain	WO	WO 97/43885	11/1997
2001/0003685	A1	6/2001	Aritani	WO	WO 97/44859	11/1997
2002/0106930	A1	8/2002	Pape et al.	WO	WO 98/15989	4/1998
2002/0142676	A1	10/2002	Hosaka et al.	WO	WO 00/16445	3/2000
2002/0159235	A1	10/2002	Miller et al.	WO	WO 01/29931	4/2001
2002/0193019	A1	12/2002	Blanchfield et al.	WO	WO 01/39332	5/2001
2003/0119378	A1	6/2003	Avery	WO	WO 2002/103847	12/2002
2003/0143894	A1	7/2003	Kline et al.	WO	WO 2005/065254	7/2005
2003/0219999	A1	11/2003	Minich et al.	WO	WO 2007/064632	6/2007
2003/0220021	A1	11/2003	Whiteman, Jr. et al.	WO	WO 02008/117180	10/2008
2003/0236035	A1	12/2003	Kuroda et al.			
2004/0077224	A1 *	4/2004	Marchese 439/696			
2005/0112952	A1	5/2005	Wang et al.			
2006/0003620	A1	1/2006	Daily et al.			
2006/0128197	A1	6/2006	McGowan et al.			
2006/0281354	A1	12/2006	Ngo et al.			
2007/0293084	A1	12/2007	Ngo			
2008/0248670	A1	10/2008	Daily et al.			

FOREIGN PATENT DOCUMENTS

DE	102 26 279	C1	11/2003
EP	0 273 683	A2	7/1988
EP	0 321 257	B1	4/1993
EP	0 623 248	B1	11/1995
EP	0 789 422	A2	8/1997
EP	1 091 449	B1	9/2004
GB	1 162 705		8/1969
JP	05344728		12/1993
JP	6068943		3/1994

OTHER PUBLICATIONS

Finan, J.M., "Thermally Conductive Thermoplastics", LNP Engineering Plastics, Inc., Plastics Engineering 2000, www.4spe.org, 4 pages.

Metral 1000 Series, PCB Mounted Receptacle Assembly, FCI Web Site page, 2001, 1 page.

Ogando, J., "And now-An Injection-Molded Heat Exchanger", Sure, plastics are thermal insulators, but additive packages allow them to conduct heat instead, Global Design News, Nov. 1, 2000, 4 pages.

Power TwinBlade™ I/O Cable Connector RA-North-South, No. GS-20_072, Aug. 6, 2007, 11 pages.

Product Datasheets, 10 Bgit/s XENPAK 850 nm Transponder (TRP10GVP2045), Copyright 2005, MergeOptics GmbH, 13 pages.

Product Datasheets, Welcome to XENPAK.org., Copyright 2001, http://www.xenpak.org., 1 page.

Sherman, L.M., "Plastics that Conduct Heat", Plastics Technology Online, Jun. 2001, http://www.plasticstechnology.com, 4 pages.

* cited by examiner

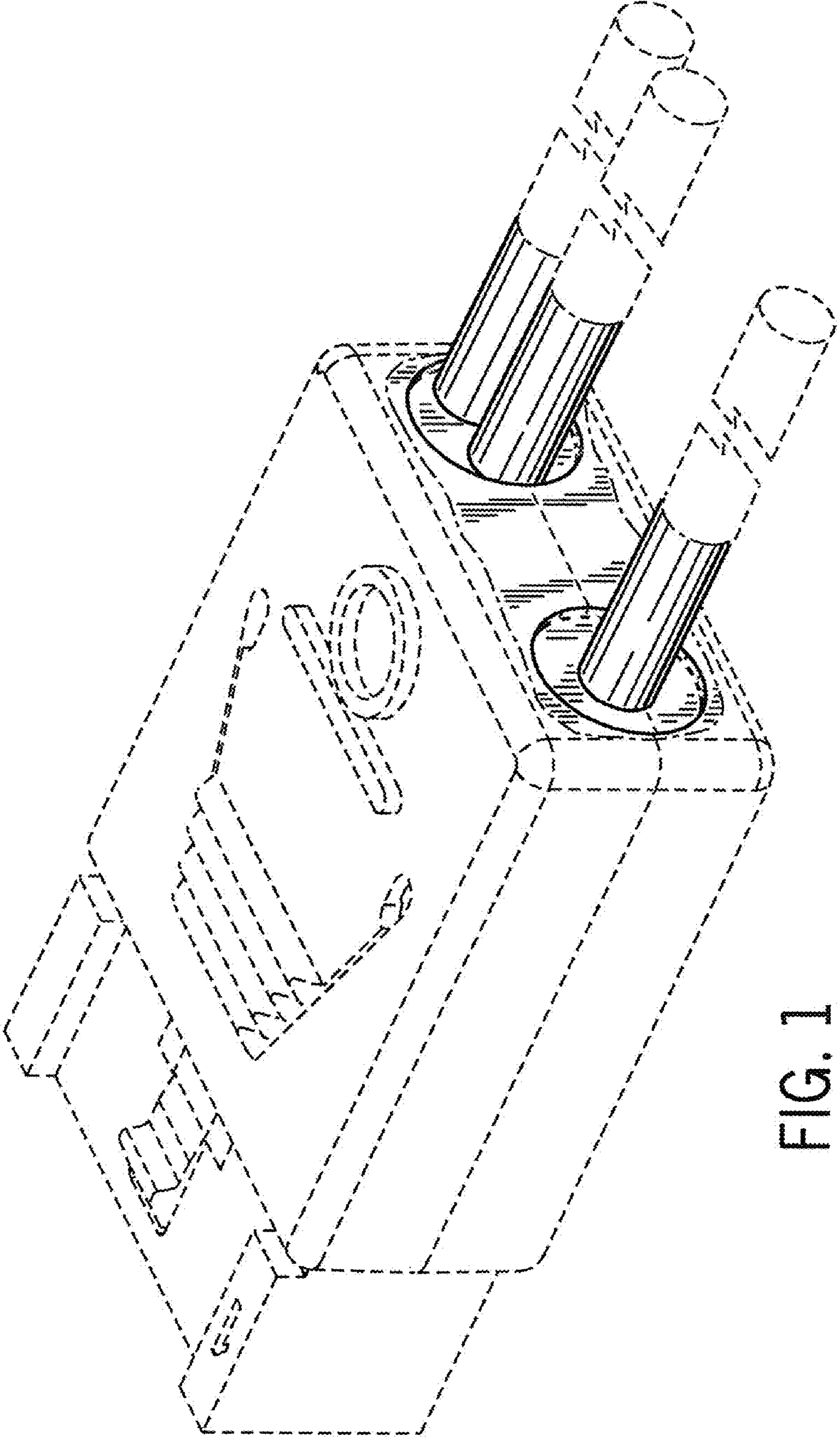

FIG. 1

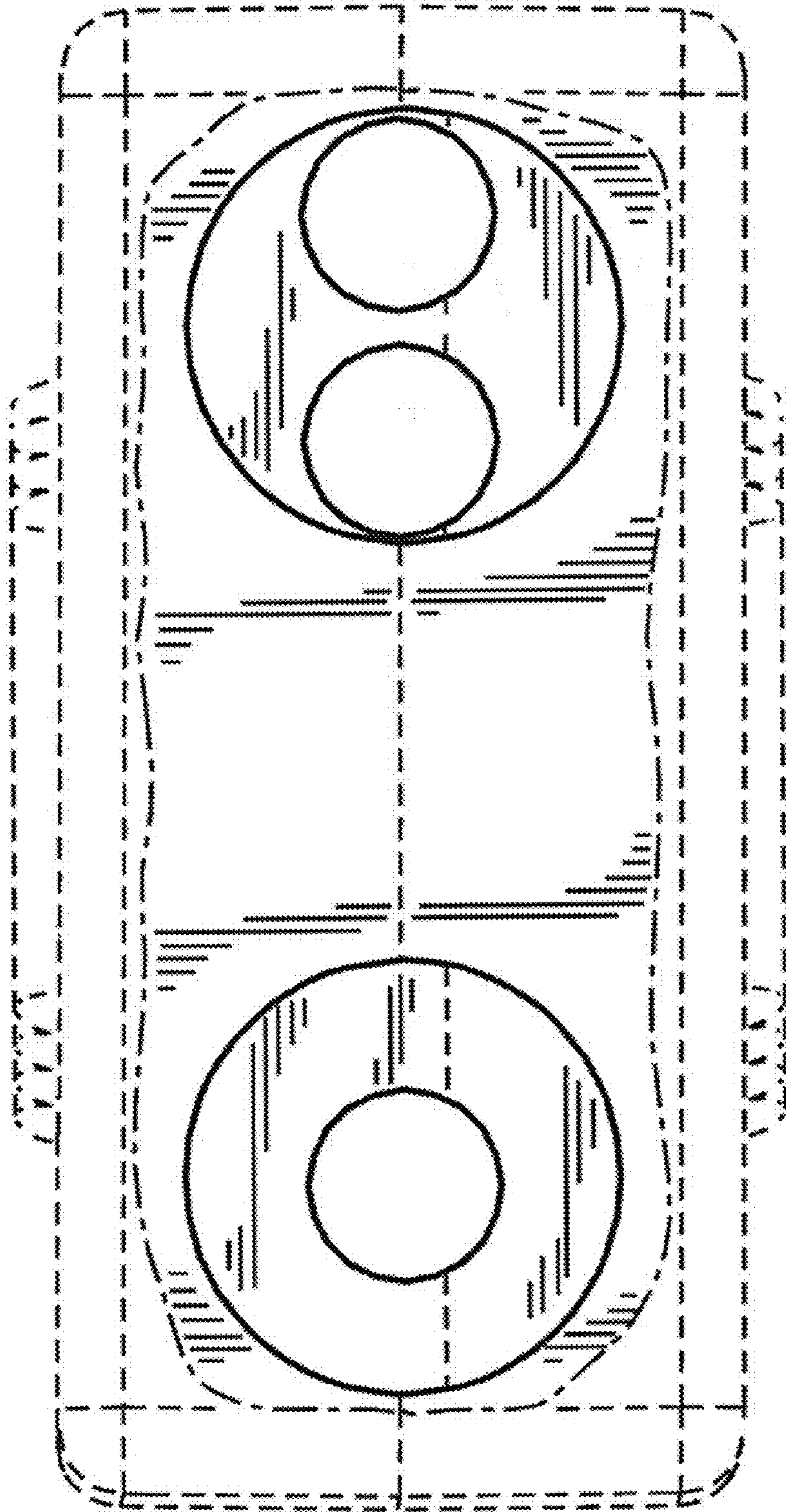

FIG. 2

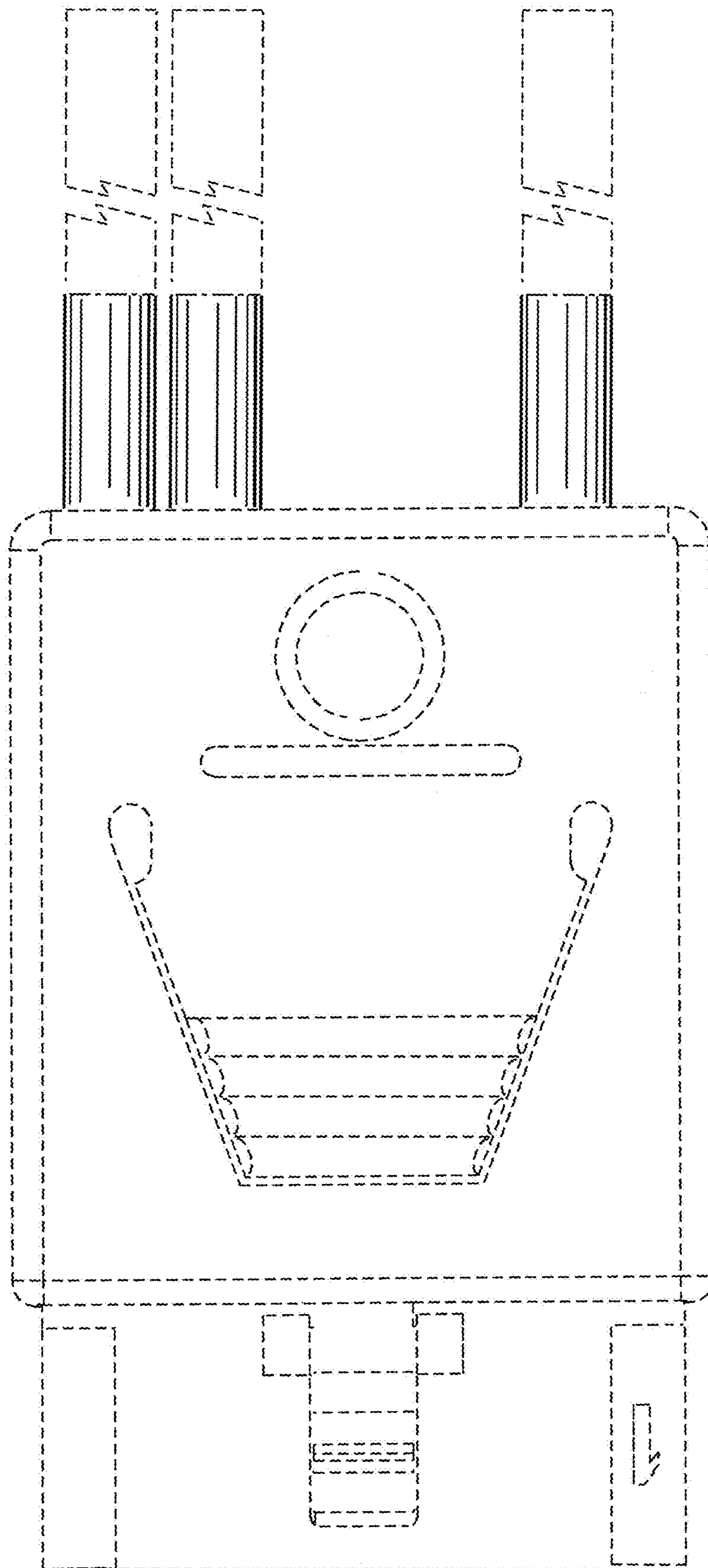

FIG. 3

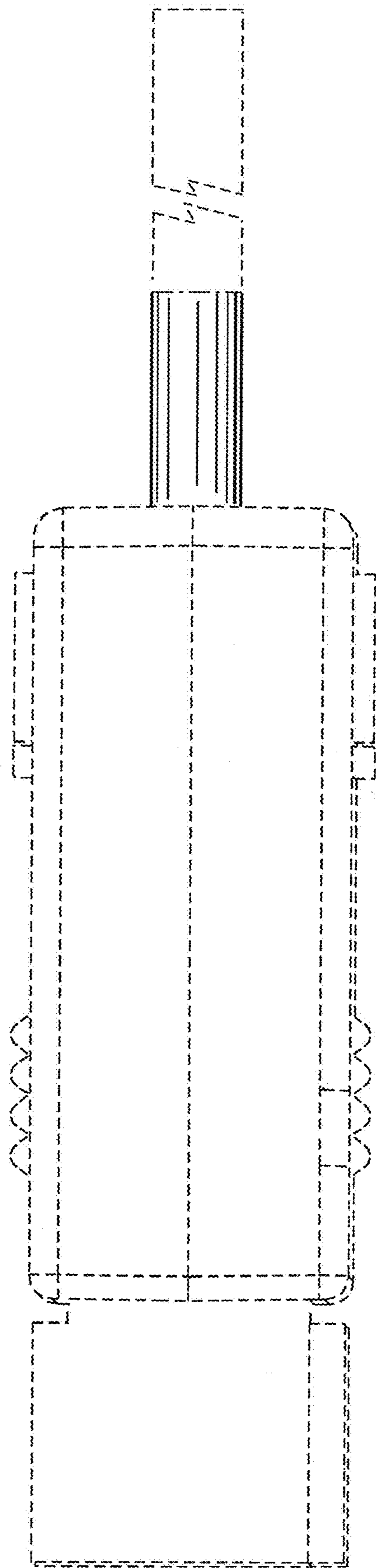

FIG. 4

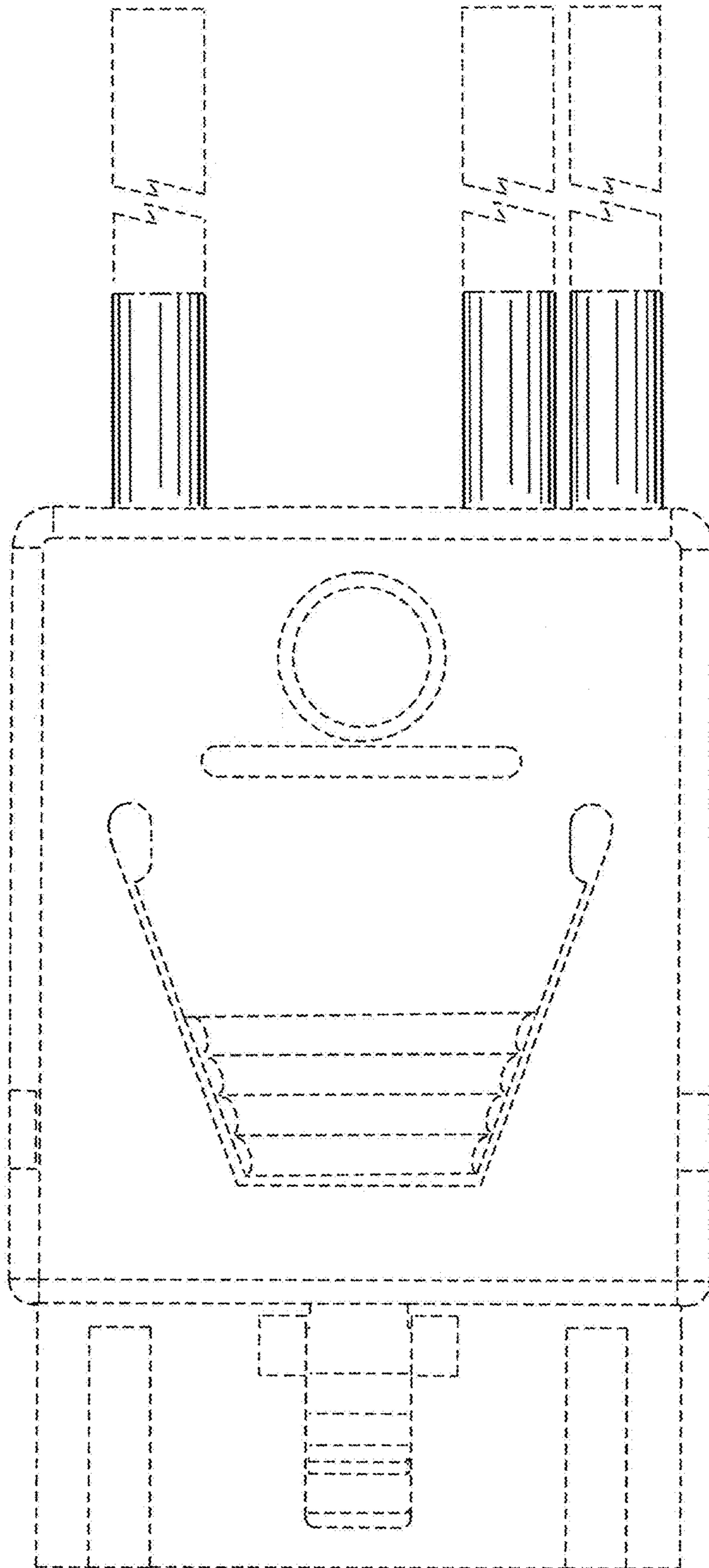

FIG. 5

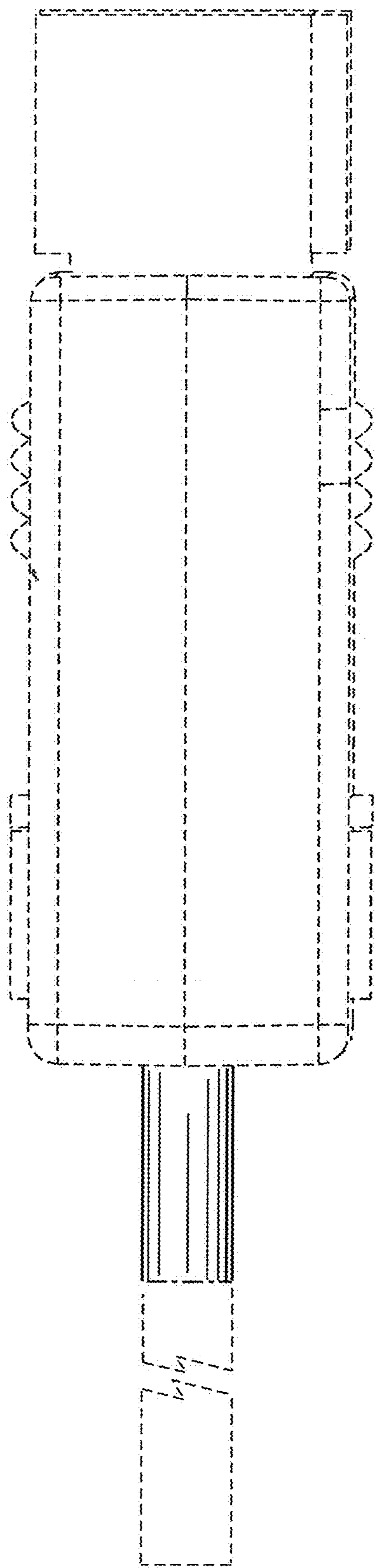

FIG. 6

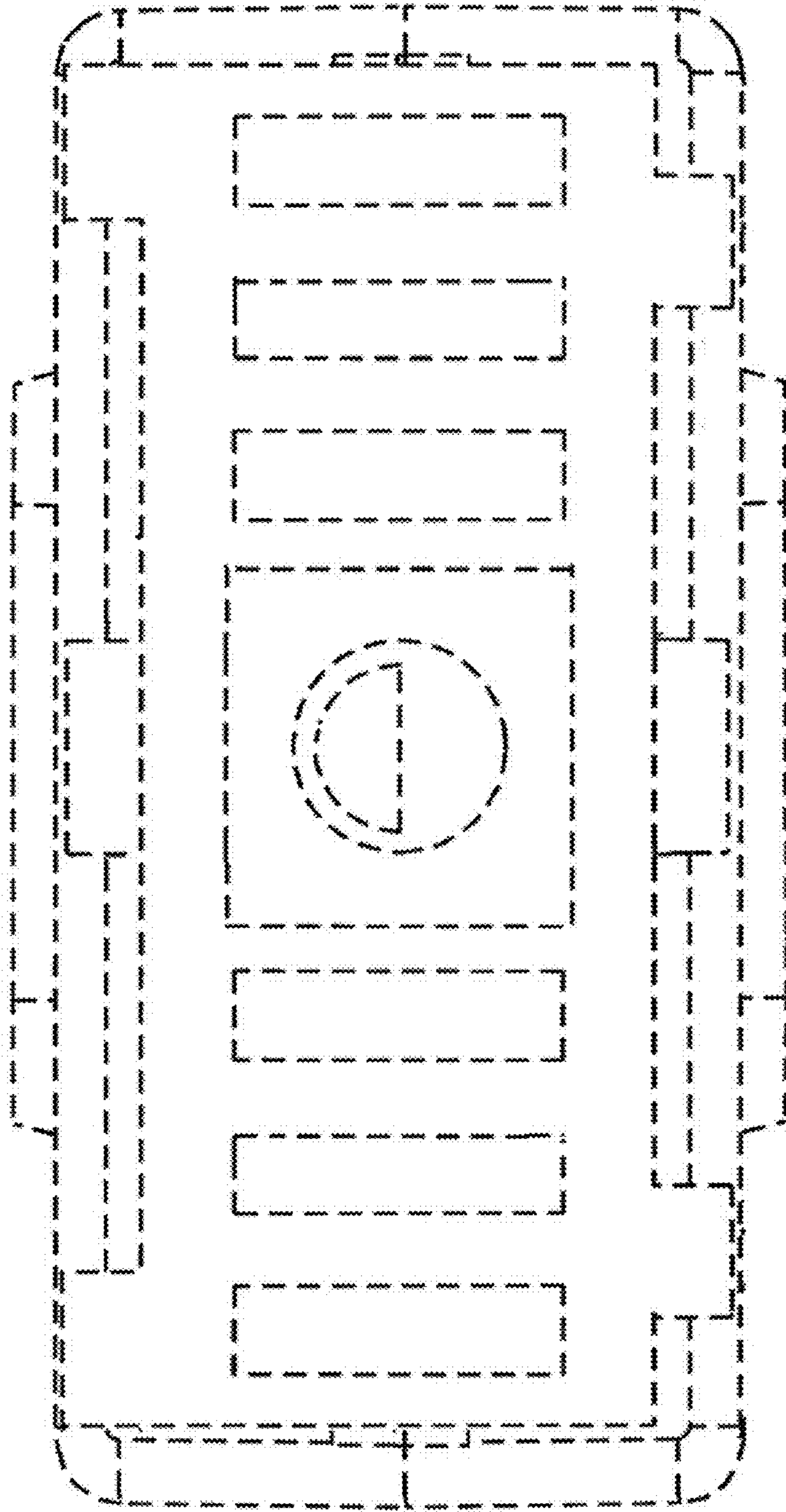

FIG. 7