



US00D618136S

(12) **United States Design Patent**
Ward

(10) **Patent No.:** **US D618,136 S**

(45) **Date of Patent:** **** Jun. 22, 2010**

(54) **SEAT BELT LOCK COVER**

(75) Inventor: **Craig Raymond Ward**, East Hills (AU)

(73) Assignee: **WWM Concepts Pty Ltd**, East Hills,
NSW (AU)

(**) Term: **14 Years**

(21) Appl. No.: **29/295,192**

(22) Filed: **Sep. 21, 2007**

(30) **Foreign Application Priority Data**

Mar. 21, 2007 (AU) 16998/2007

(51) **LOC (9) Cl.** **02-07**

(52) **U.S. Cl.** **D11/200**

(58) **Field of Classification Search** D11/1-2,
D11/200-201, 203-206, 210, 212, 214-219,
D11/222, 224, 226; 24/163 R, 169-171,
24/173, 177-179, 191, 194-195, 197, 200
See application file for complete search history.

(56) **References Cited**

U.S. PATENT DOCUMENTS

D30,301 S * 2/1899 Lipman D11/210

D49,930 S * 11/1916 Lighter D11/210
D70,026 S * 4/1926 Morse D11/216
D301,084 S * 5/1989 Mathews D2/639
D415,067 S * 10/1999 Tung D11/200
D565,461 S * 4/2008 Johnson et al. D11/216
D567,707 S * 4/2008 Yeates et al. D11/200

* cited by examiner

Primary Examiner—Ralf Seifert

(74) *Attorney, Agent, or Firm*—Knobbe, Martens, Olson &
Bear, LLP

(57) **CLAIM**

The ornamental design for a seat belt lock cover, as shown and described.

DESCRIPTION

FIG. 1 is a front perspective view of a seat belt lock cover of the present invention;

FIG. 2 is a rear perspective view of the seat belt lock cover of FIG. 1;

FIG. 3 is a side view of the seat belt lock cover of FIG. 1;

FIG. 4 is a top view of the seat belt lock cover of FIG. 1; and,

FIG. 5 is a bottom view of the seat belt lock cover of FIG. 1.

1 Claim, 3 Drawing Sheets

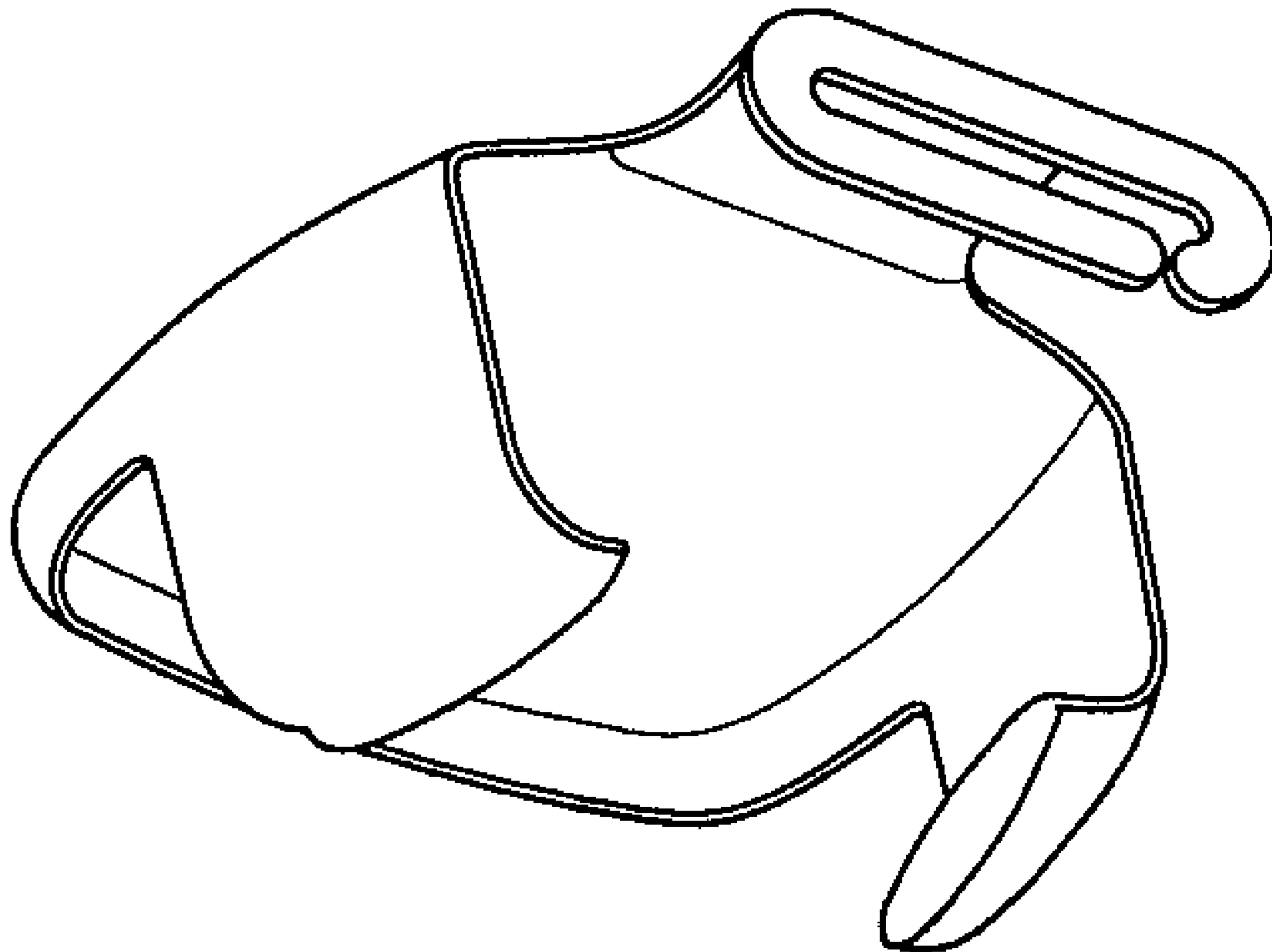

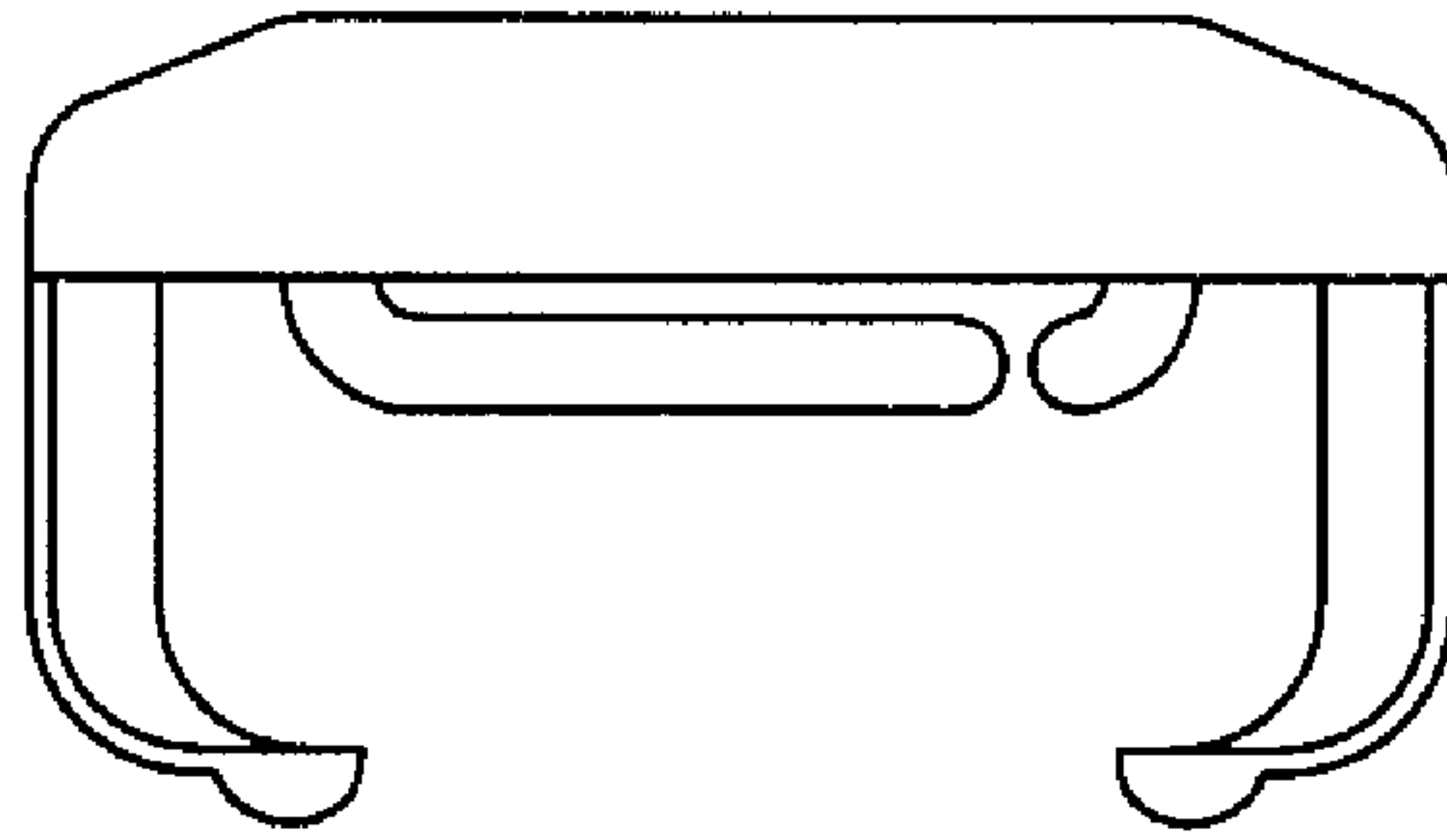

FIG. 1

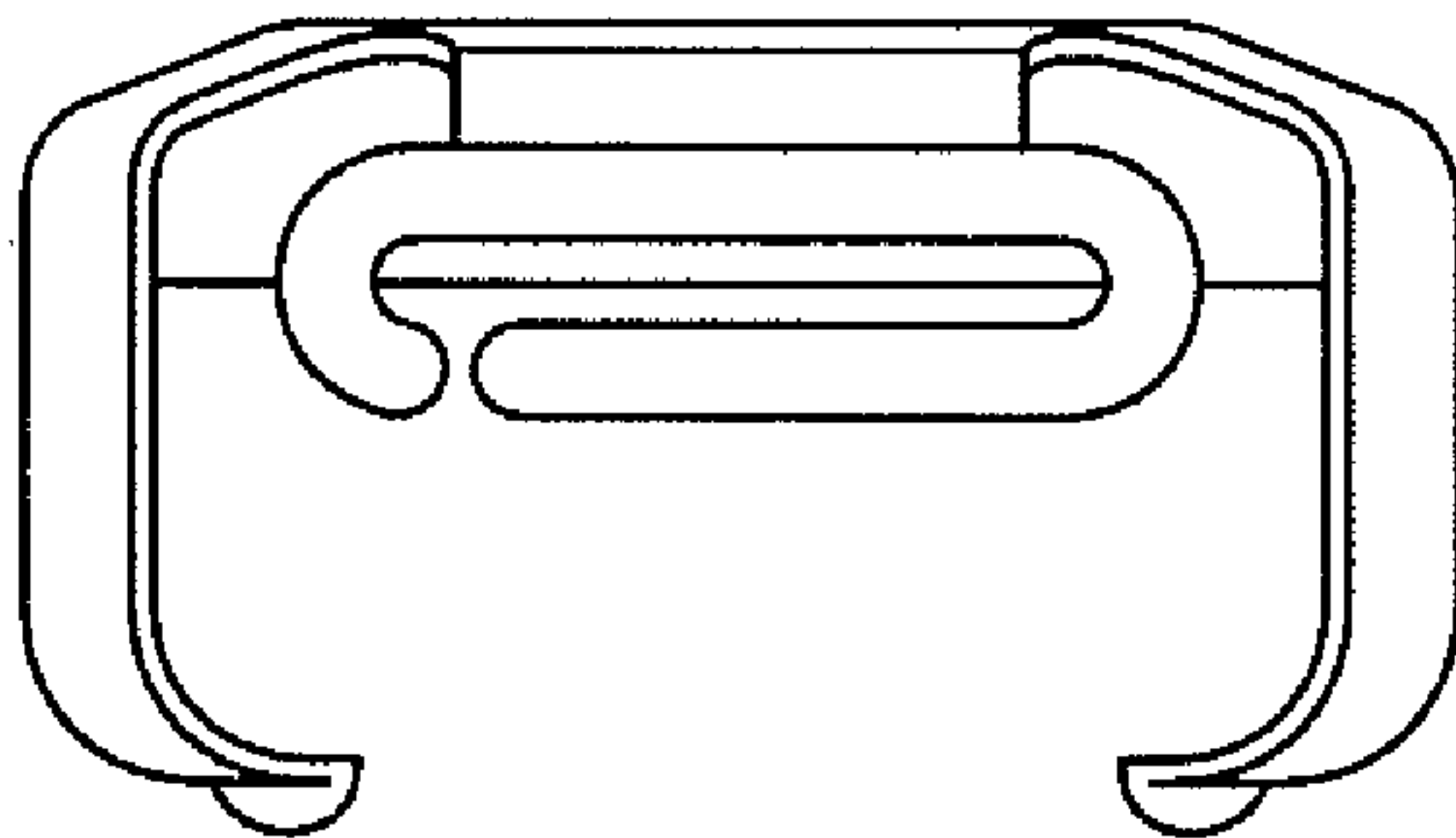

FIG. 2

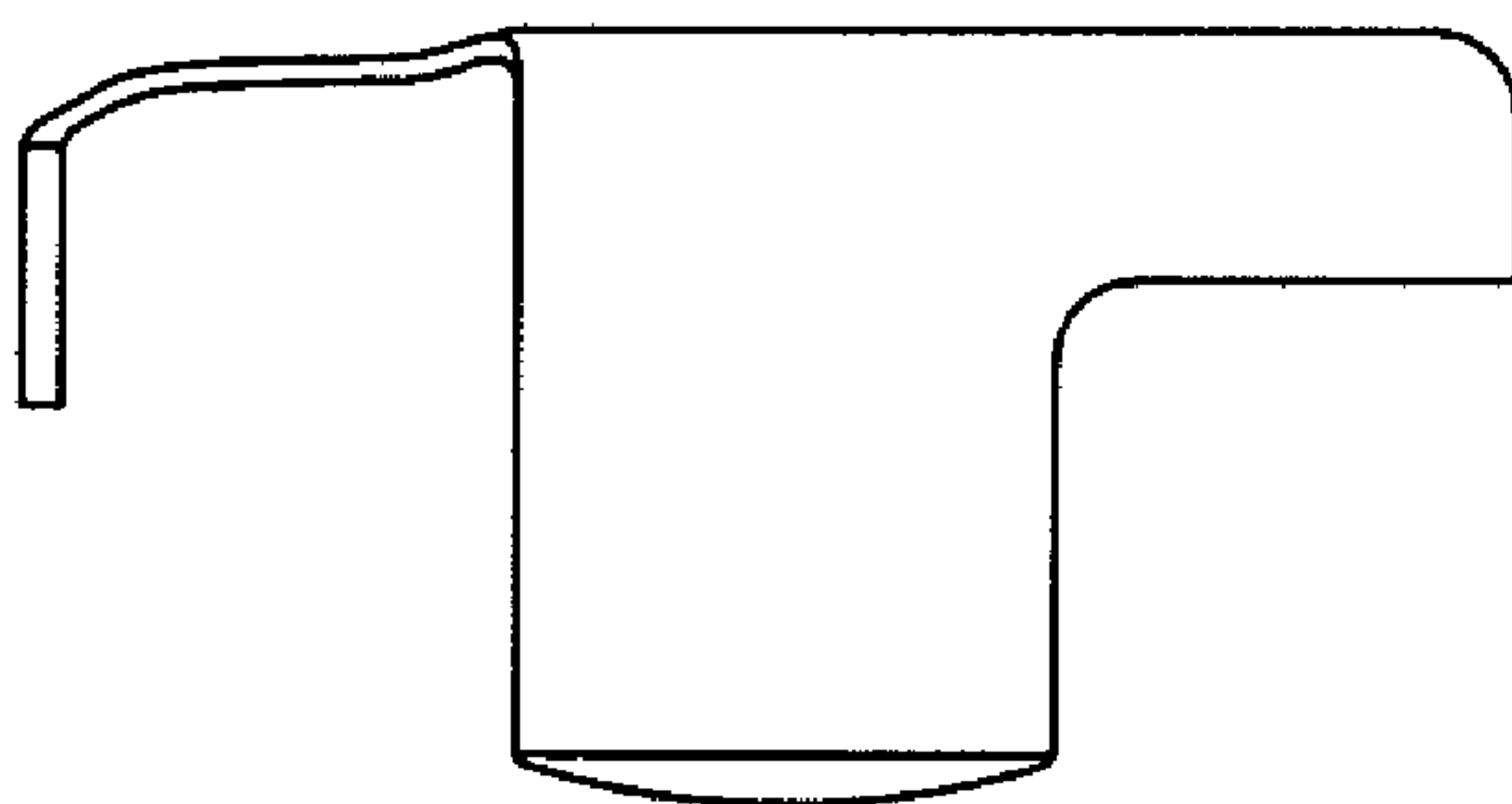

FIG. 3

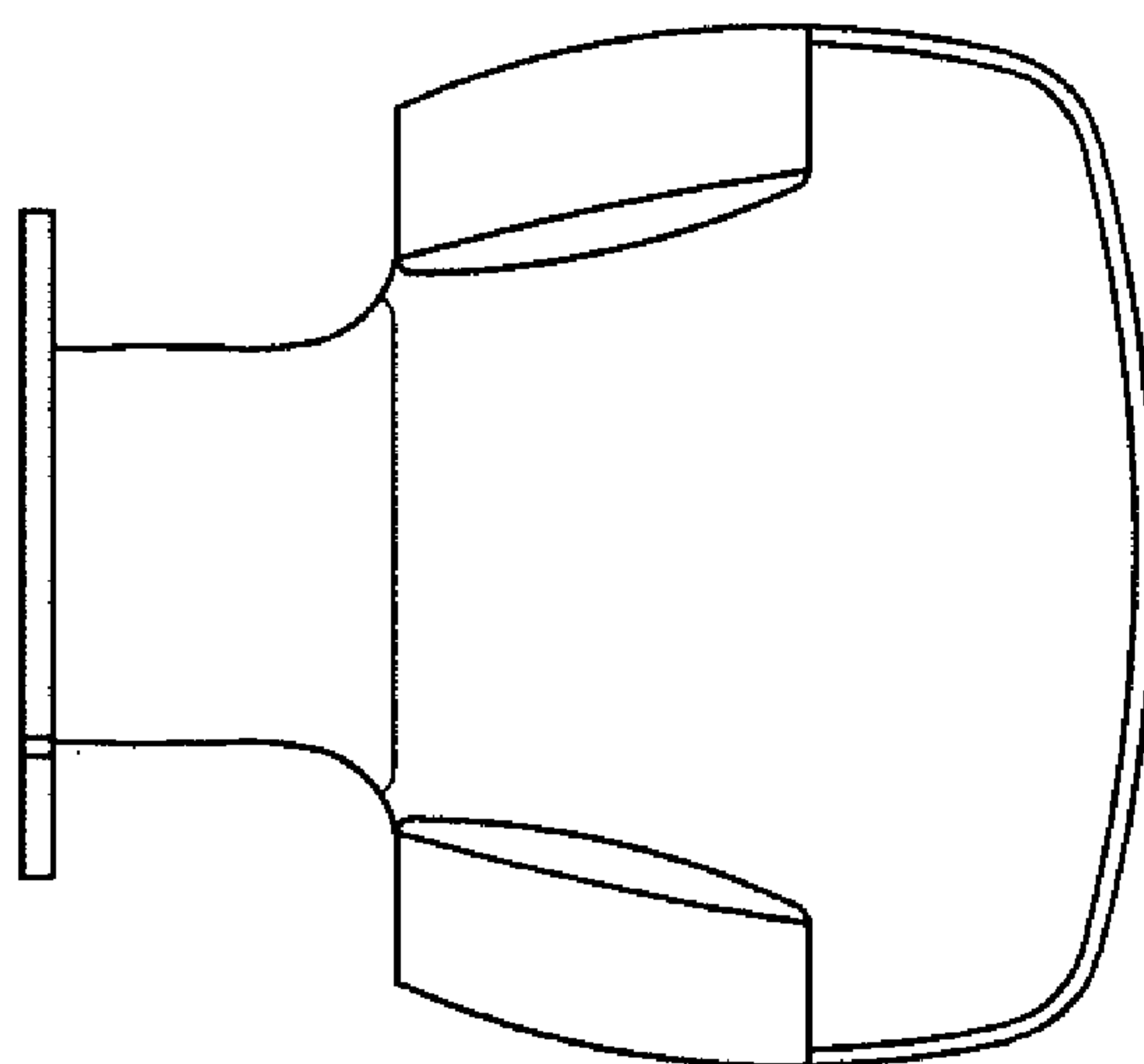

FIG. 4

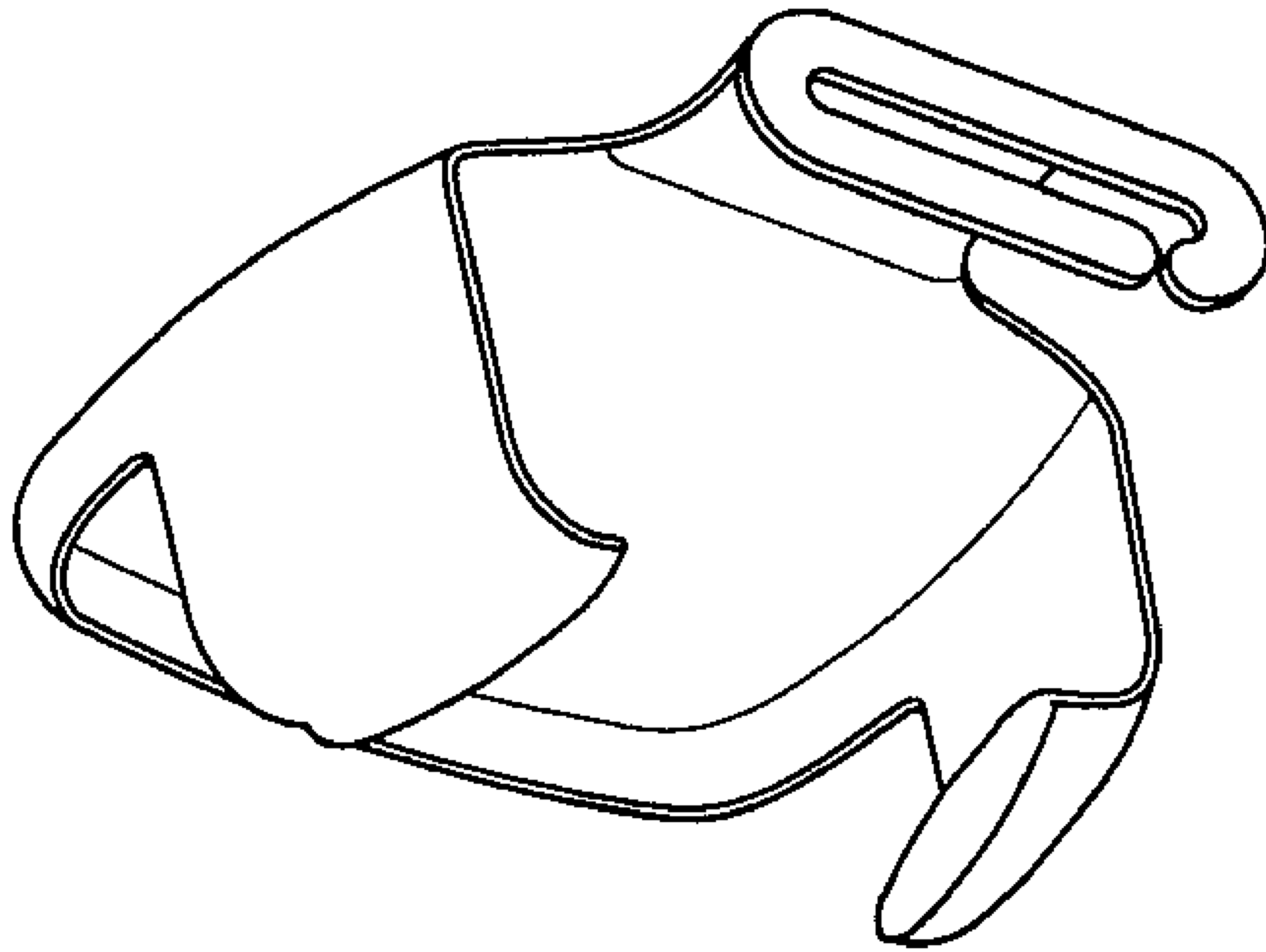

FIG. 5