



US00D618079S

(12) **United States Design Patent**
Blythe et al.

(10) **Patent No.:** **US D618,079 S**
(45) **Date of Patent:** **** Jun. 22, 2010**

(54) **ROTARY TOOL**

(75) Inventors: **Daniel Blythe**, Buffalo Grove, IL (US);
Brian Benes, Libertyville, IL (US);
Michael Landt, Chicago, IL (US);
Adam Erwin, Chicago, IL (US);
Kristina Petrović, Chicago, IL (US)

(73) Assignee: **Robert Bosch GmbH**, Stuttgart (DE)

(**) Term: **14 Years**

(21) Appl. No.: **29/346,901**

(22) Filed: **Nov. 9, 2009**

(51) **LOC (9) Cl.** **08-01**

(52) **U.S. Cl.** **D8/61**

(58) **Field of Classification Search** D8/61,
D8/62, 67, 69; 81/57, 57.11, 57.14, 57.26,
81/429, 464, 469; 173/2, 170, 176, 181
See application file for complete search history.

(56) **References Cited**

U.S. PATENT DOCUMENTS

D308,622 S *	6/1990	Fushiya et al.	D8/61
5,298,821 A	3/1994	Michel	
D374,159 S	10/1996	Chiang	
D378,727 S	4/1997	Kikuchi	
D391,820 S *	3/1998	Bunyea	D8/61
D410,829 S	6/1999	Heun	
D414,668 S	10/1999	Duennes et al.	
D423,897 S *	5/2000	Cooper	D8/61
D424,613 S *	5/2000	Chiang	D18/57
D427,038 S *	6/2000	Lin	D8/61
D427,040 S	6/2000	Heun	
D433,905 S	11/2000	Cooper	
D437,758 S	2/2001	Heun	
D446,431 S *	8/2001	Lui	D8/61
D446,432 S *	8/2001	Heun	D8/61
D459,176 S *	6/2002	Duennes	D8/61
D469,671 S	2/2003	Prell et al.	
D477,202 S	7/2003	Duennes	

D477,510 S	7/2003	Duennes	
D477,758 S *	7/2003	Chunn et al.	D8/64
D491,031 S *	6/2004	Davis et al.	D8/61
D507,730 S *	7/2005	Oles et al.	D8/61
D509,719 S *	9/2005	Chu	D8/61
D510,848 S	10/2005	Singh et al.	
D529,354 S	10/2006	Davis et al.	
D556,000 S	11/2007	Singh et al.	
D577,974 S *	10/2008	Miller	D8/70

* cited by examiner

Primary Examiner—Cathron C Brooks

Assistant Examiner—Austin Murphy

(74) *Attorney, Agent, or Firm*—Maginot, Moore & Beck

(57) **CLAIM**

The ornamental design for a rotary tool, as shown and described.

DESCRIPTION

FIG. 1 is a perspective view of a rotary tool showing our new design;

FIG. 2 is a right side elevational view showing the design for the rotary tool of FIG. 1;

FIG. 3 is a left side elevational view showing the design for the rotary tool of FIG. 1;

FIG. 4 is a top elevational view showing the design for the rotary tool of FIG. 1;

FIG. 5 is a bottom elevational view showing the design for the rotary tool of FIG. 1;

FIG. 6 is a front elevational view showing the design for the rotary tool of FIG. 1; and,

FIG. 7 is a rear elevational view showing the design for the rotary tool of FIG. 1.

The broken line showing of portions of the rotary tool is included for illustrative purposes only and forms no part of the claimed design.

1 Claim, 6 Drawing Sheets

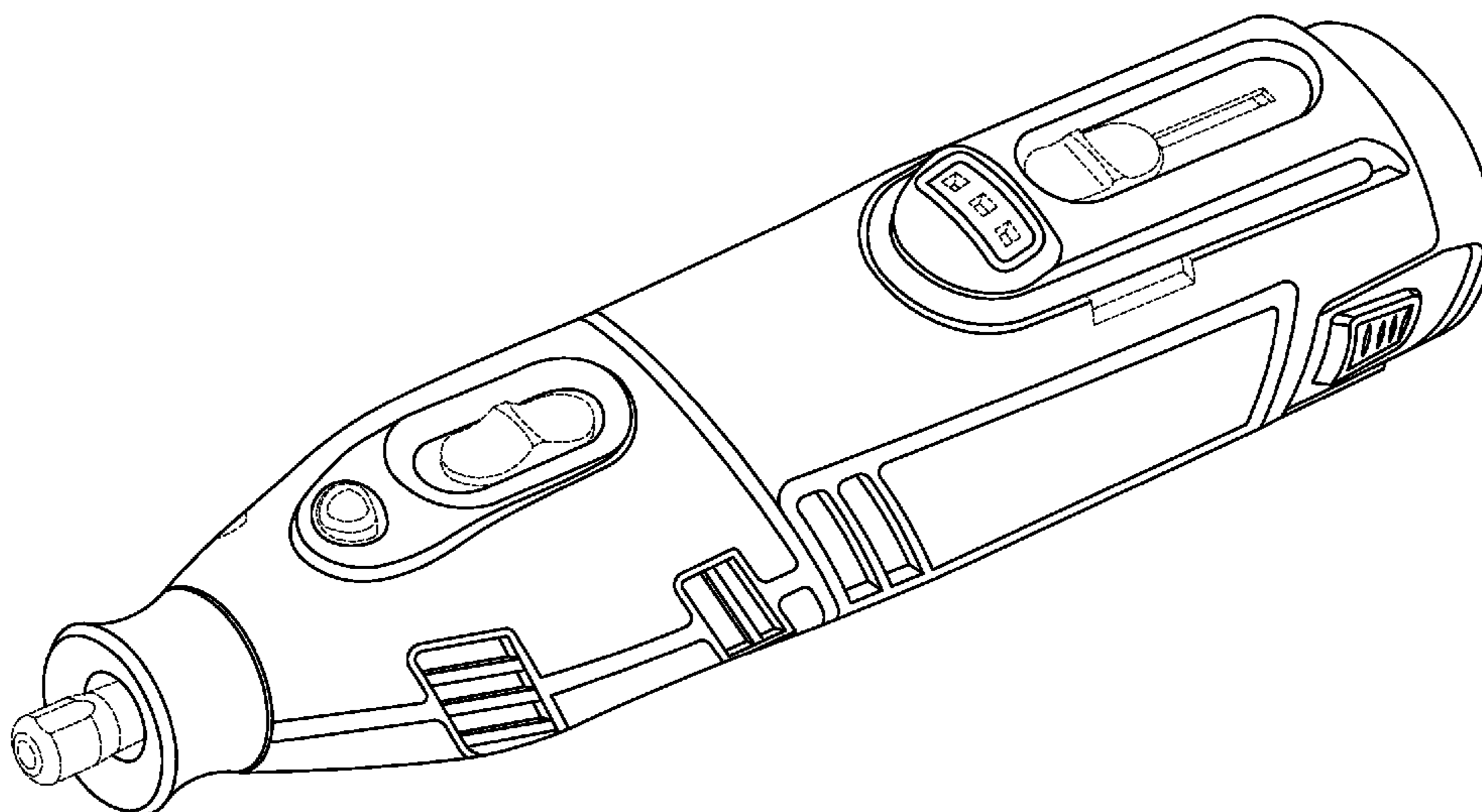

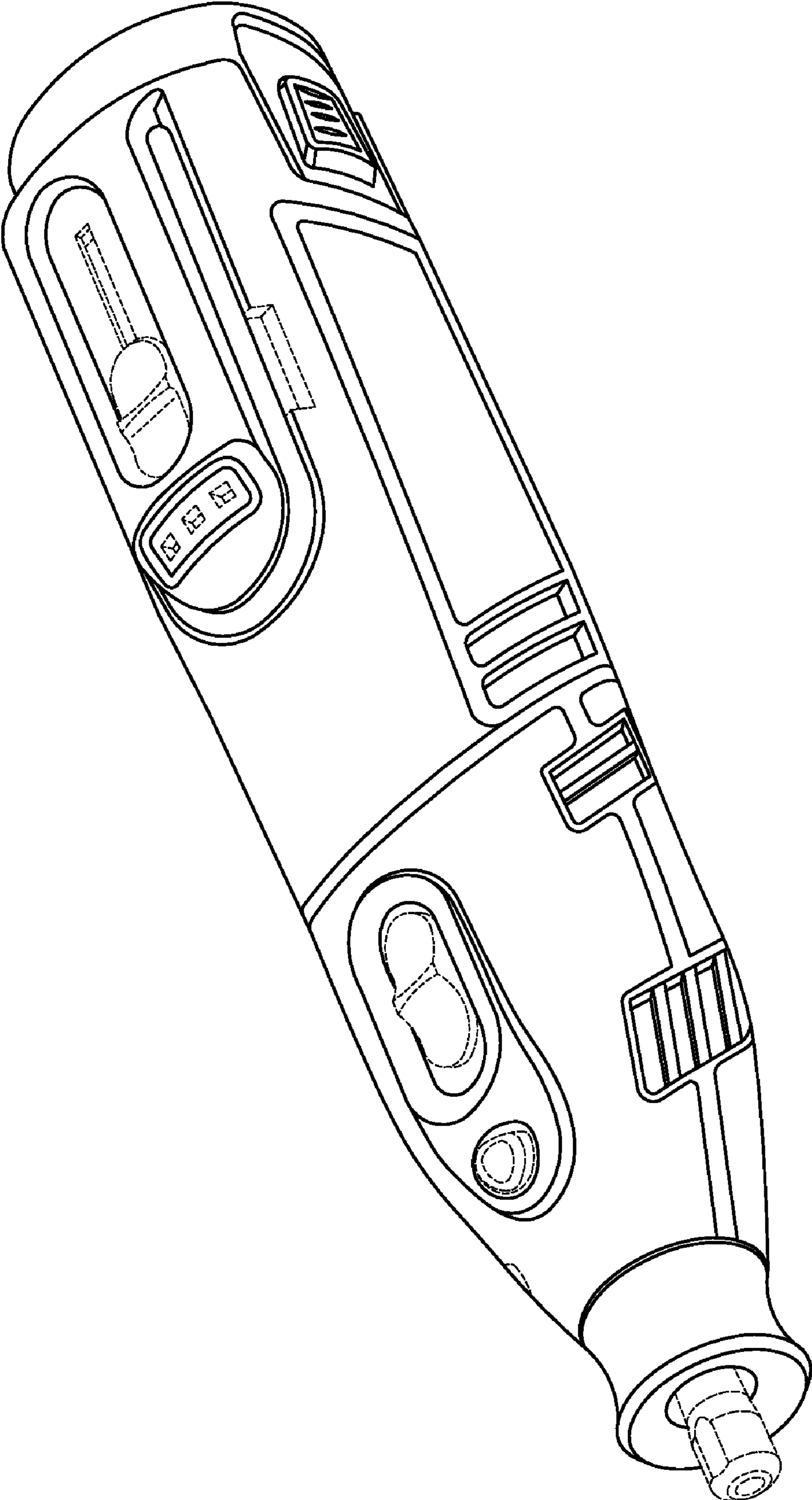

Fig. 1

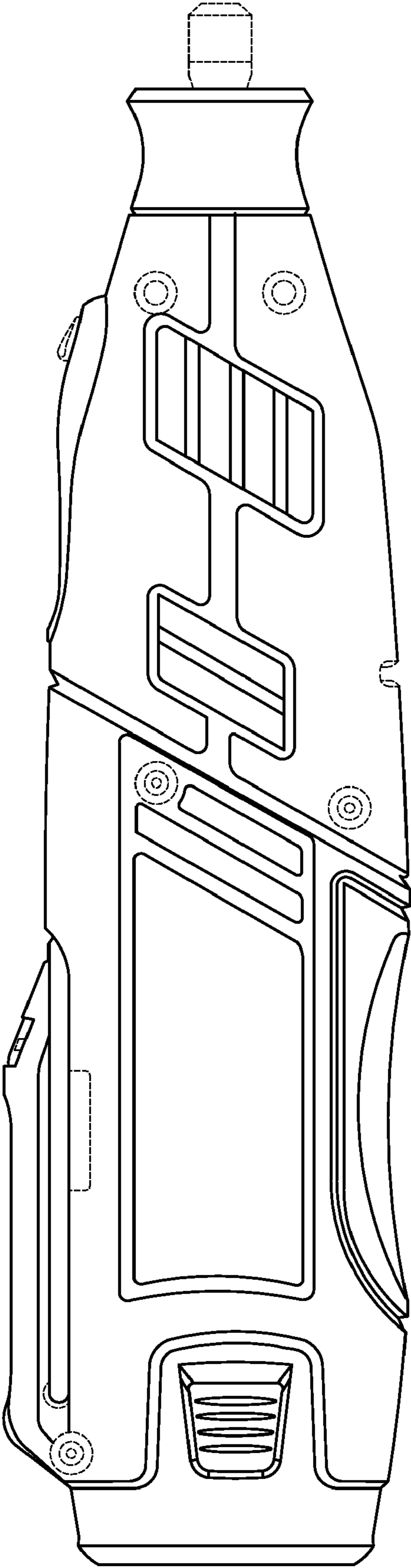

Fig. 2

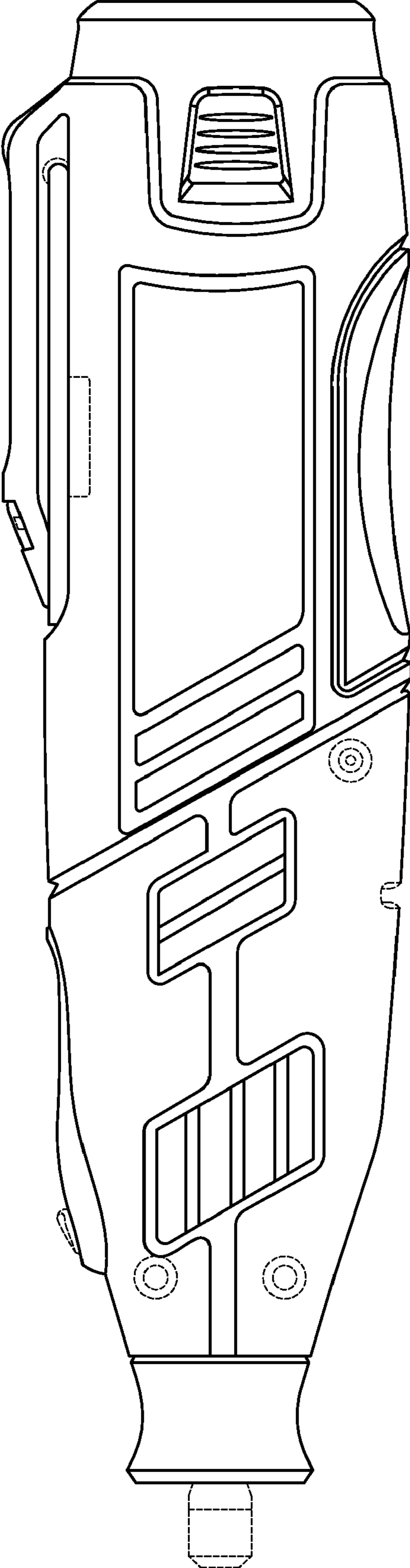

Fig. 3

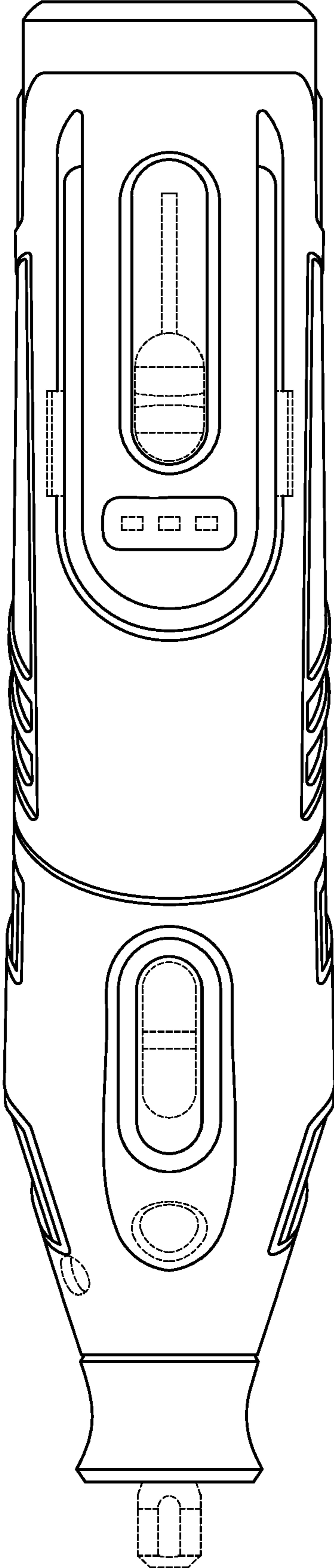

Fig. 4

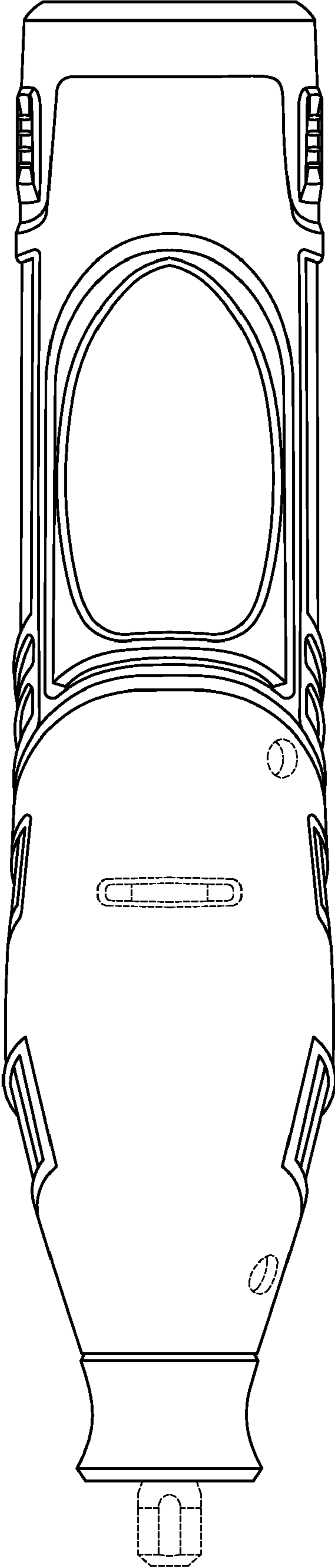

Fig. 5

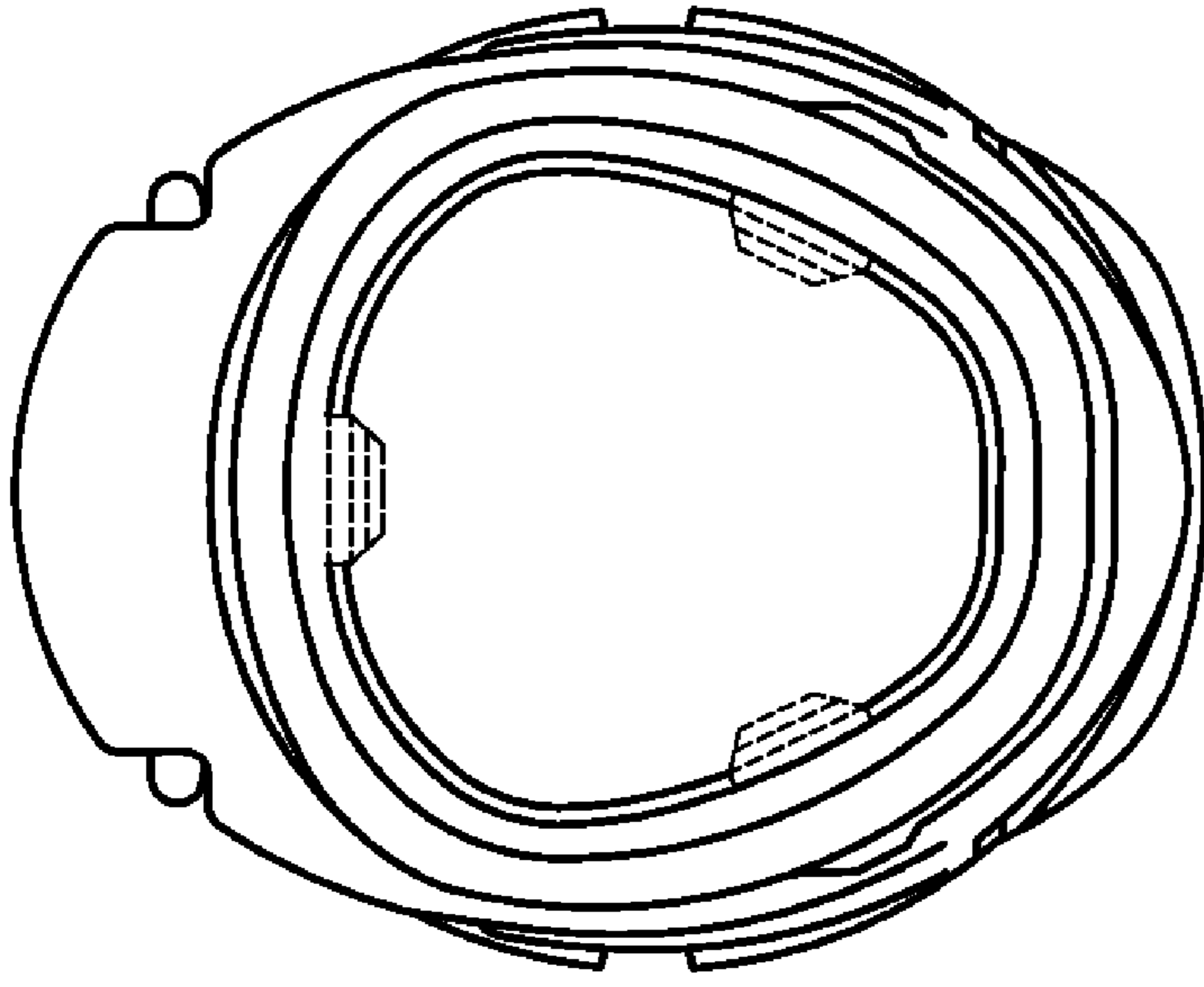

Fig. 6

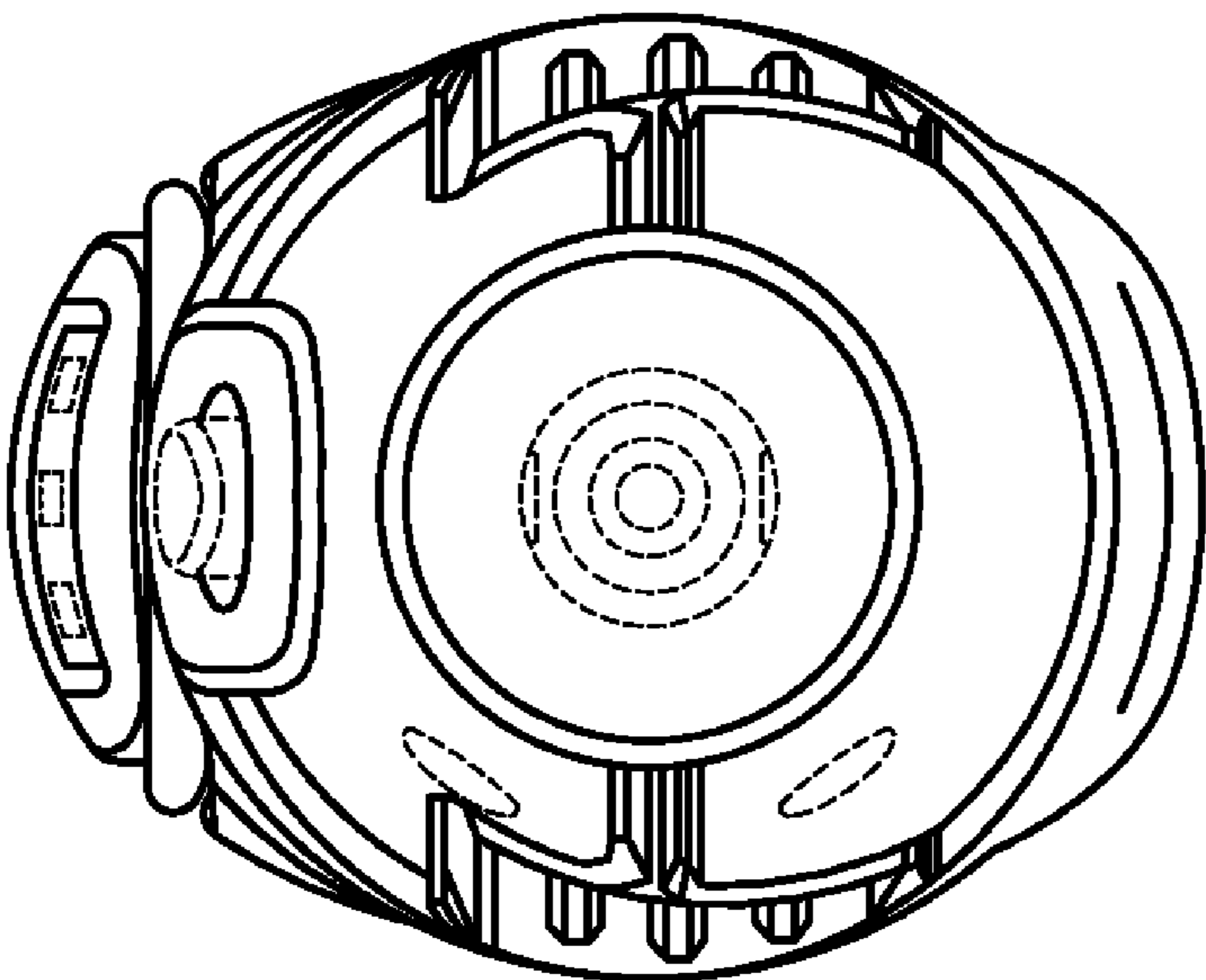

Fig. 7