



US00D617893S

(12) **United States Design Patent**
Bierman et al.

(10) **Patent No.:** **US D617,893 S**
(45) **Date of Patent:** **** *Jun. 15, 2010**

(54) **ACCESS DEVICE**

(75) Inventors: **Steven F. Bierman**, Del Mar, CA (US);
Richard A. Pluth, San Diego, CA (US)

(73) Assignee: **Access Scientific, Inc.**, San Diego, CA
(US)

(*) Notice: This patent is subject to a terminal disclaimer.

(**) Term: **14 Years**

(21) Appl. No.: **29/343,774**

(22) Filed: **Sep. 18, 2009**

Related U.S. Application Data

(63) Continuation of application No. 29/305,172, filed on
Mar. 14, 2008, now Pat. No. Des. 601,242.

(51) **LOC (9) Cl.** **12-11**

(52) **U.S. Cl.** **D24/112**

(58) **Field of Classification Search** D24/112-114,
D24/108, 133, 186, 130; 606/181, 185; 604/264,
604/162, 232, 187, 160
See application file for complete search history.

(56) **References Cited**

U.S. PATENT DOCUMENTS

3,565,074 A 2/1971 Foti et al.
3,995,628 A 12/1976 Gula et al.

(Continued)

FOREIGN PATENT DOCUMENTS

EP 0139091 7/1984
EP 0502714 11/1995
EP 0730880 9/1996
KR 20050027359 3/2005
WO WO02/36179 5/2002

OTHER PUBLICATIONS

A photograph of various access devices.

(Continued)

Primary Examiner—T. Chase Nelson
Assistant Examiner—David G Muller

(74) *Attorney, Agent, or Firm*—Knobbe, Martens, Olson &
Bear LLP

(57) **CLAIM**

The ornamental design for an access device, as shown and
described.

DESCRIPTION

FIG. 1 is a front side perspective view of an access device
configured in accordance with a preferred embodiment of the
present invention;

FIG. 2 is a top view of the access device shown in FIG. 1;

FIG. 3 is a first side view of the access device shown in FIG.
1, the other side being a mirror image of the first side;

FIG. 4 is a bottom view of the access device shown in FIG. 1;

FIG. 5 is a first end view of the access device shown in FIG.
1;

FIG. 6 is a second end view of the access device shown in FIG.
1;

FIG. 7 is a front side perspective view of an access device
configured in accordance with another preferred embodiment
of the present invention;

FIG. 8 is a top view of the access device shown in FIG. 7;

FIG. 9 is a first side view of the access device shown in FIG.
7, the other side being a mirror image of the first side;

FIG. 10 is a bottom view of the access device shown in FIG.
7;

FIG. 11 is a first end view of the access device shown in FIG.
7; and,

FIG. 12 is a second end view of the access device shown in
FIG. 7.

The features shown in broken lines in FIG. 1 depict environ-
mental subject matter only and form no part of the claimed
design.

1 Claim, 4 Drawing Sheets

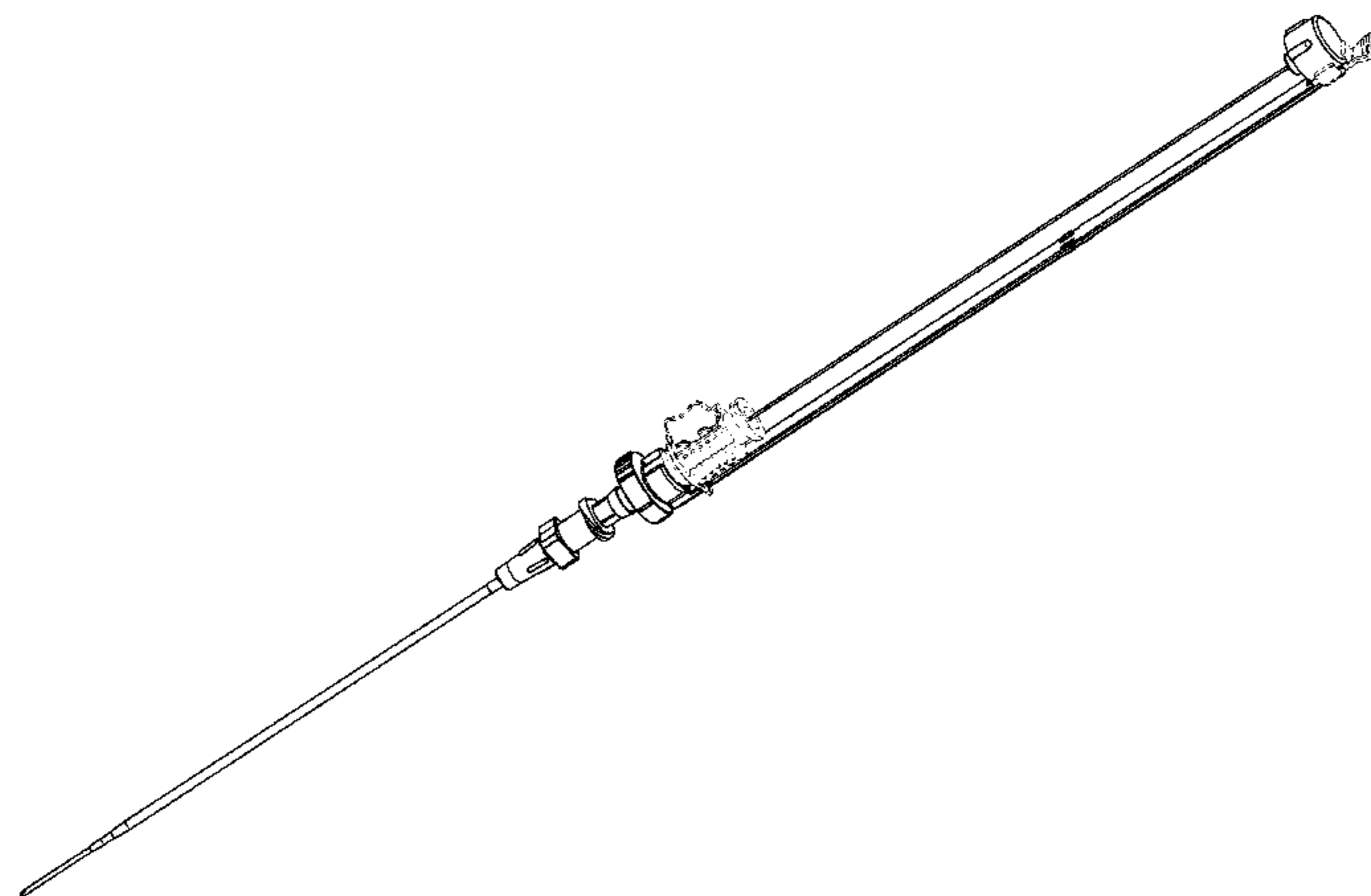

US D617,893 S

Page 2

U.S. PATENT DOCUMENTS

4,068,659 A	1/1978	Moorehead		5,919,160 A	7/1999	Sanfilippo
4,205,675 A	6/1980	Vaillancourt		5,935,110 A	8/1999	Brimhall
D264,133 S *	4/1982	Genese	D24/112	6,027,480 A	2/2000	Davis et al.
4,411,655 A	10/1983	Schreck		6,046,143 A	4/2000	Khan et al.
4,417,886 A	11/1983	Frankhouser et al.		6,080,141 A	6/2000	Castro et al.
4,525,157 A	6/1985	Vaillancourt		6,120,494 A	9/2000	Jonkman
4,581,019 A	4/1986	Curelaru et al.		6,146,401 A *	11/2000	Yoon et al. 604/264
D283,921 S *	5/1986	Dyak	D24/114	6,159,179 A	12/2000	Simonson
4,629,450 A	12/1986	Suzuki et al.		6,179,813 B1	1/2001	Ballow et al.
4,655,750 A	4/1987	Vaillancourt		6,217,556 B1 *	4/2001	Ellingson et al. 604/264
4,661,300 A	4/1987	Daugherty		D445,495 S *	7/2001	Schaefer et al. D24/108
4,772,264 A	9/1988	Cragg		6,273,871 B1	8/2001	Davis et al.
4,791,937 A	12/1988	Wang		6,277,100 B1	8/2001	Raulerson
4,850,975 A	7/1989	Furukawa		6,336,914 B1	1/2002	Gillespie, III
4,894,052 A	1/1990	Crawford		D460,179 S *	7/2002	Isoda et al. D24/130
4,944,728 A	7/1990	Carrell		6,436,070 B1	8/2002	Botich et al.
4,955,890 A	9/1990	Yamamoto et al.		6,461,362 B1	10/2002	Halseth et al.
4,961,729 A	10/1990	Vaillancourt		6,475,207 B1	11/2002	Maginot
4,978,334 A	12/1990	Toye et al.		6,488,662 B2	12/2002	Sirimanne
4,995,866 A	2/1991	Amplatz et al.		6,500,152 B1	12/2002	Illi
5,066,284 A	11/1991	Mersch et al.		6,524,277 B1	2/2003	Chang
5,098,392 A	3/1992	Fleischhacker et al.		6,607,511 B2	8/2003	Halseth et al.
5,108,374 A	4/1992	Lemieux		6,626,868 B1	9/2003	Prestidge et al.
5,114,401 A	5/1992	Stuart et al.		6,641,564 B1	11/2003	Kraus
5,158,544 A	10/1992	Weinstein		6,692,462 B2	2/2004	Mackenzie et al.
5,171,218 A	12/1992	Fonger et al.		6,692,482 B2	2/2004	Heller et al.
5,242,410 A	9/1993	Melker		6,695,816 B2	2/2004	Cassidy
5,242,427 A	9/1993	Bilweis		6,726,659 B1	4/2004	Stocking et al.
5,246,426 A	9/1993	Lewis et al.		6,808,520 B1	10/2004	Fourkas
5,250,038 A	10/1993	Melker et al.		6,836,687 B2	12/2004	Kelley
5,295,969 A	3/1994	Fischell		6,905,481 B2	6/2005	Sirimanne
5,295,970 A	3/1994	Clinton et al.		6,994,693 B2	2/2006	Tal
5,306,253 A	4/1994	Brimhall		7,001,396 B2	2/2006	Glazier et al.
5,312,355 A	5/1994	Lee		7,018,390 B2 *	3/2006	Turovskiy et al. 606/185
5,328,480 A	7/1994	Melker et al.		7,025,746 B2	4/2006	Tal
5,330,433 A	7/1994	Fonger et al.		D558,339 S *	12/2007	Christopher et al. D24/130
5,336,191 A	8/1994	Davis et al.		D579,554 S *	10/2008	Targell et al. D24/112
5,342,315 A	8/1994	Rowe et al.		2002/0072712 A1	6/2002	Nool et al.
5,366,441 A	11/1994	Crawford		2002/0087076 A1	7/2002	Meguro et al.
5,380,290 A	1/1995	Makower et al.		2003/0153874 A1	8/2003	Tal
5,391,178 A	2/1995	Yapor		2003/0216771 A1	11/2003	Osyypka et al.
5,512,052 A	4/1996	Jesch		2004/0092879 A1	5/2004	Kraus et al.
5,542,932 A	8/1996	Daugherty		2004/0171988 A1	9/2004	Moretti
5,589,120 A	12/1996	Khan et al.		2004/0193112 A1	9/2004	Glazier et al.
5,676,689 A	10/1997	Kensley et al.		2005/0075656 A1 *	4/2005	Beaupre 606/185
5,688,249 A	11/1997	Chang et al.		2006/0015071 A1	1/2006	Fitzgerald
5,690,619 A	11/1997	Erskine		2006/0129100 A1	6/2006	Tal
5,704,914 A	1/1998	Stocking et al.		2007/0282300 A1	12/2007	Attawia et al.
5,728,132 A	3/1998	Van Tassel et al.		2008/0262430 A1	10/2008	Anderson et al.
5,762,636 A *	6/1998	Rupp et al.	604/264	2008/0262431 A1	10/2008	Anderson et al.
D397,434 S *	8/1998	Pike	D24/112	2008/0294111 A1	11/2008	Tal et al.
5,795,339 A *	8/1998	Erskine	604/264	2009/0221961 A1	9/2009	Tal et al.
5,810,780 A	9/1998	Brimhall et al.				
5,820,596 A	10/1998	Rosen et al.				
5,827,202 A	10/1998	Miraki et al.				
5,830,190 A	11/1998	Howell				
5,833,662 A	11/1998	Stevens				
5,858,002 A	1/1999	Jesch				
5,885,217 A	3/1999	Gisselberg et al.				
5,885,283 A	3/1999	Liu				
5,904,657 A	5/1999	Unsworth et al.				

OTHER PUBLICATIONS

Arrow Trauma Products No. TRM-C 12/00 11M, Arrow International, dated 2000.
 Photos of a peripheral emergency infusion device Applicant believes to be produced by Arrow International Inc.
 Photos of a splittable catheter design.
 Photos of an infusion device Applicant believes to be produced by B. Braun Medical Inc.

* cited by examiner

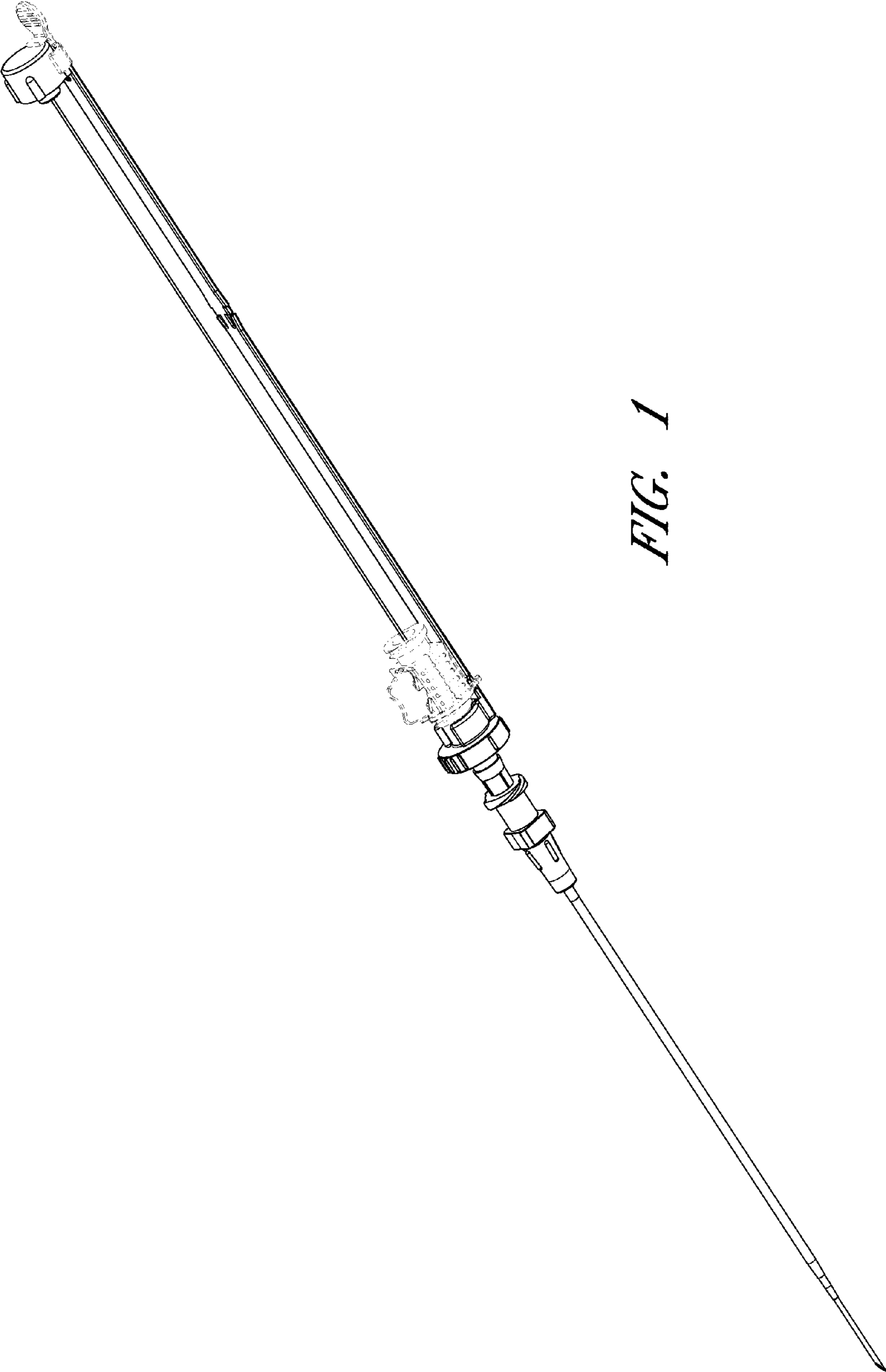

FIG. 1

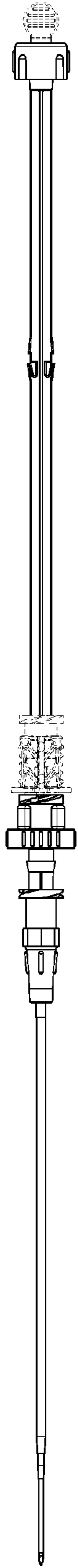

FIG. 2

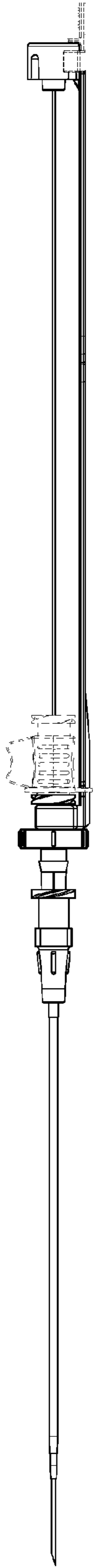

FIG. 3

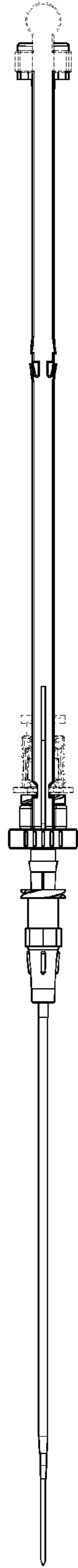

FIG. 4



FIG. 5

FIG. 6

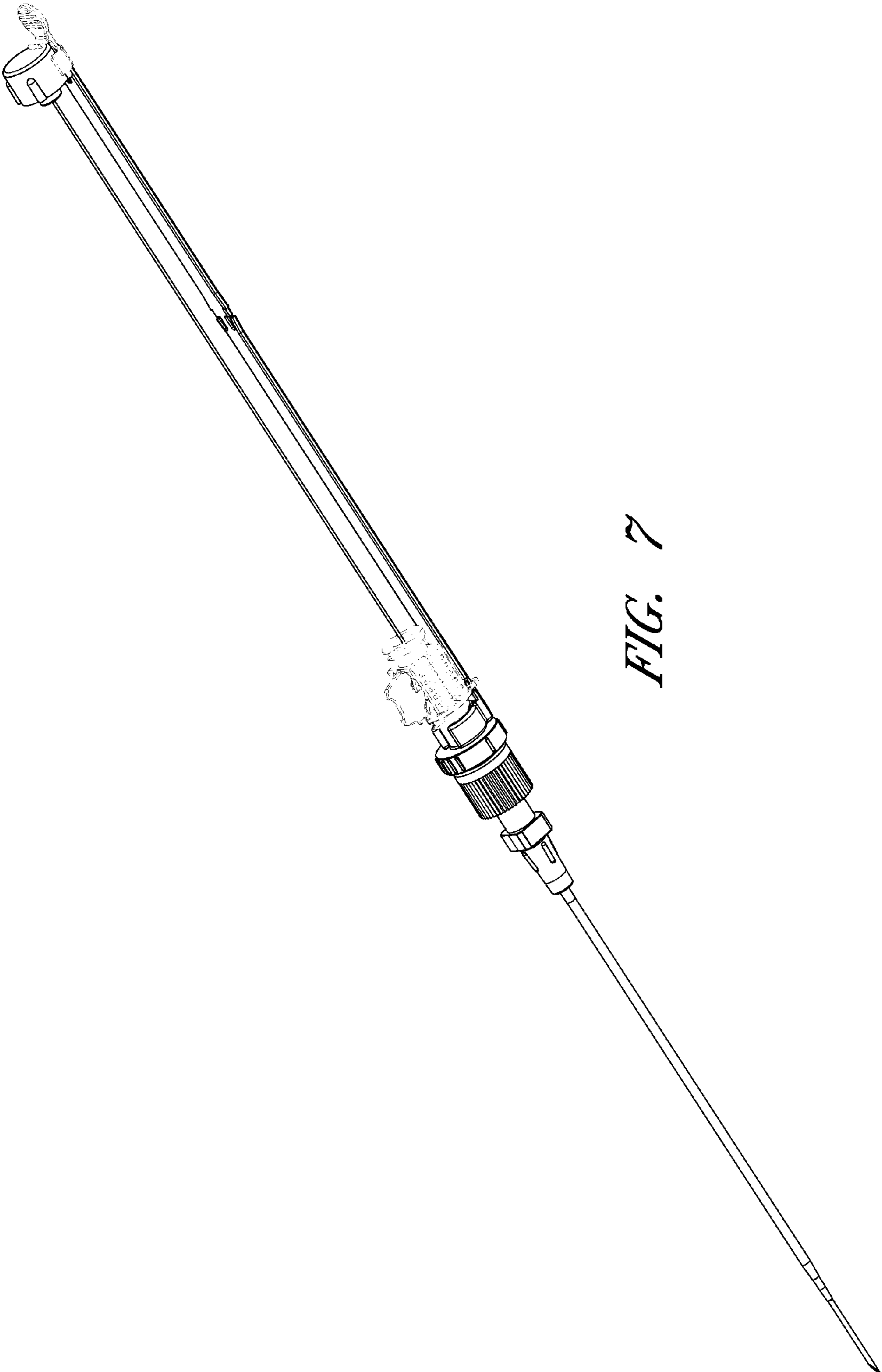

FIG. 7

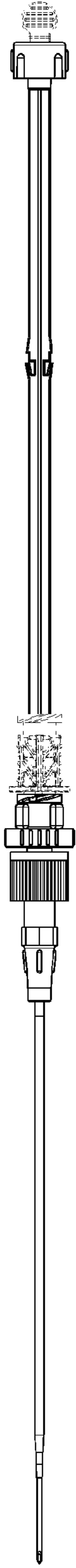

FIG. 8

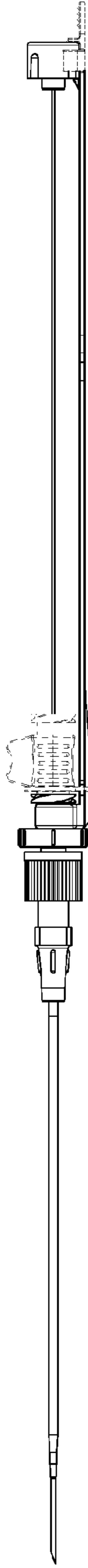

FIG. 9

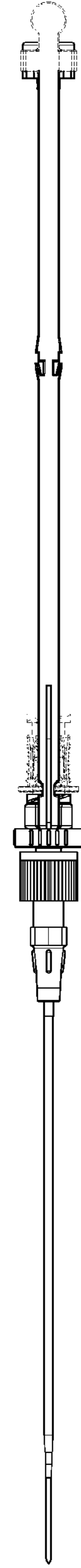

FIG. 10



FIG. 11

FIG. 12