



US00D617822S

(12) **United States Design Patent**
Kawabe et al.

(10) **Patent No.:** **US D617,822 S**
(45) **Date of Patent:** **** Jun. 15, 2010**

(54) **PROJECTOR**

(75) Inventors: **Genta Kawabe**, Matsumoto (JP); **Isao Sakamaki**, Matsumoto (JP); **Tsuyoshi Arai**, Matsumoto (JP); **Keisuke Sakagami**, Suwa (JP); **Sei Nakanishi**, Matsumoto (JP); **Yasushi Tateno**, Matsumoto (JP)

(73) Assignee: **Seiko Epson Corporation**, Tokyo (JP)

(**) Term: **14 Years**

(21) Appl. No.: **29/335,084**

(22) Filed: **Apr. 8, 2009**

(30) **Foreign Application Priority Data**

Dec. 4, 2008 (JP) 2008-031038

(51) **LOC (9) Cl.** **16-02**

(52) **U.S. Cl.** **D16/225; D16/230**

(58) **Field of Classification Search** D16/205, D16/208, 213, 221, 225, 230–232, 234–235; D21/514; 353/115, 119, 122; 352/34, 242–243
See application file for complete search history.

(56) **References Cited**

U.S. PATENT DOCUMENTS

D204,032 S * 3/1966 Herbst et al. D16/234
3,344,710 A * 10/1967 Bersudsky D16/225
4,969,733 A * 11/1990 Jewison 353/119
D321,527 S * 11/1991 Kurozumi et al. D16/234

D332,473 S * 1/1993 Chan D21/514
D341,136 S * 11/1993 Shimizu et al. D16/221
D343,850 S * 2/1994 Saeki et al. D16/234
D371,564 S * 7/1996 Sunada et al. D16/231
D421,269 S * 2/2000 Murakami D16/231
D498,488 S * 11/2004 Oota et al. D16/225
2005/0041221 A1 * 2/2005 Buroni 353/119

* cited by examiner

Primary Examiner—Ian Simmons

Assistant Examiner—Wan Laymon

(74) *Attorney, Agent, or Firm*—Oliff & Berridge, PLC.

(57) **CLAIM**

The ornamental design for a projector, as shown and described.

DESCRIPTION

FIG. 1 is a front perspective view of a projector;

FIG. 2 is a bottom perspective view thereof;

FIG. 3 is a front view thereof;

FIG. 4 is a rear view thereof;

FIG. 5 is a left-side view thereof;

FIG. 6 is a right-side view thereof;

FIG. 7 is a top view thereof; and,

FIG. 8 is a bottom view thereof.

The broken lines depict environmental subject matter only and form no part of the claimed design.

1 Claim, 8 Drawing Sheets

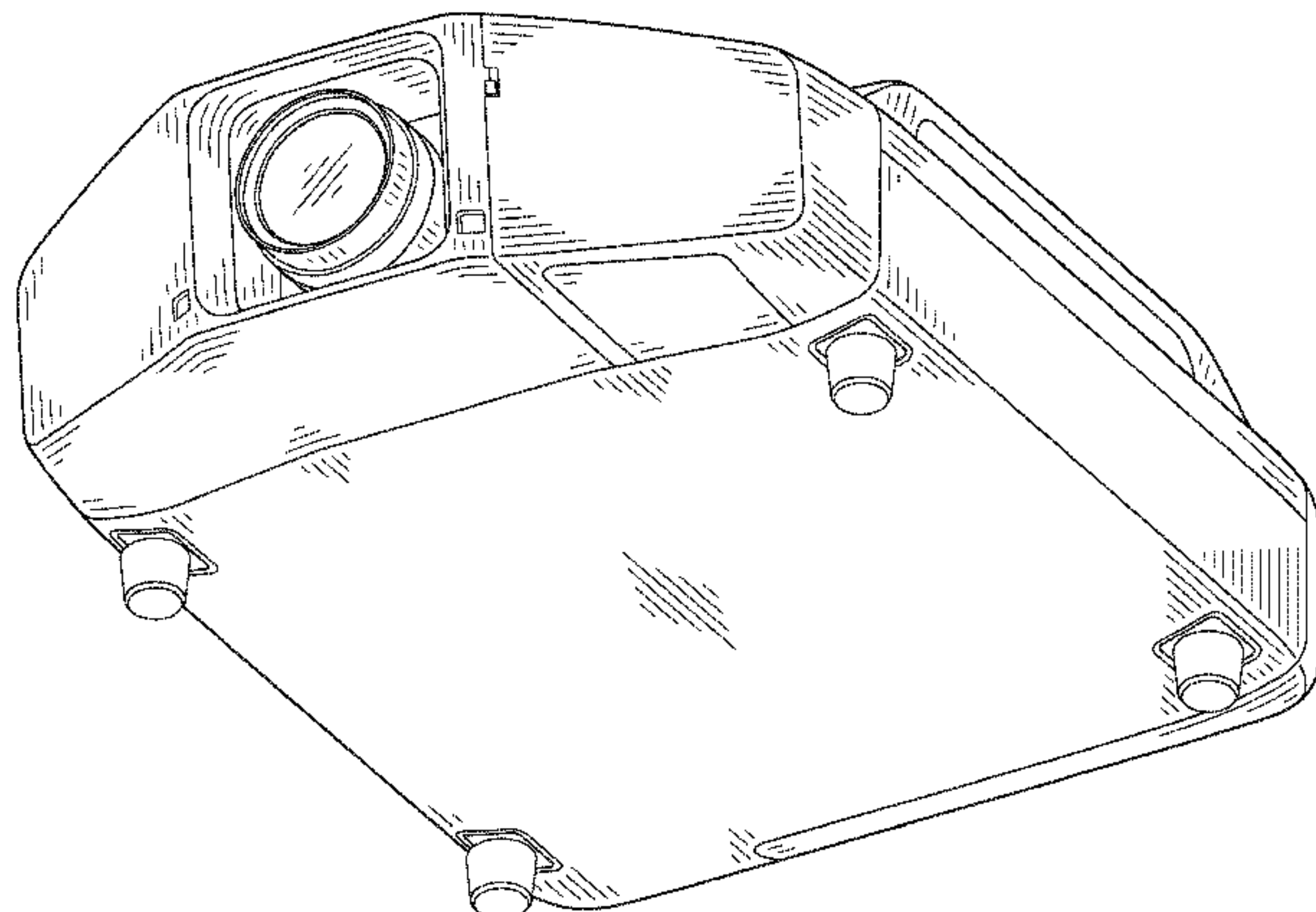
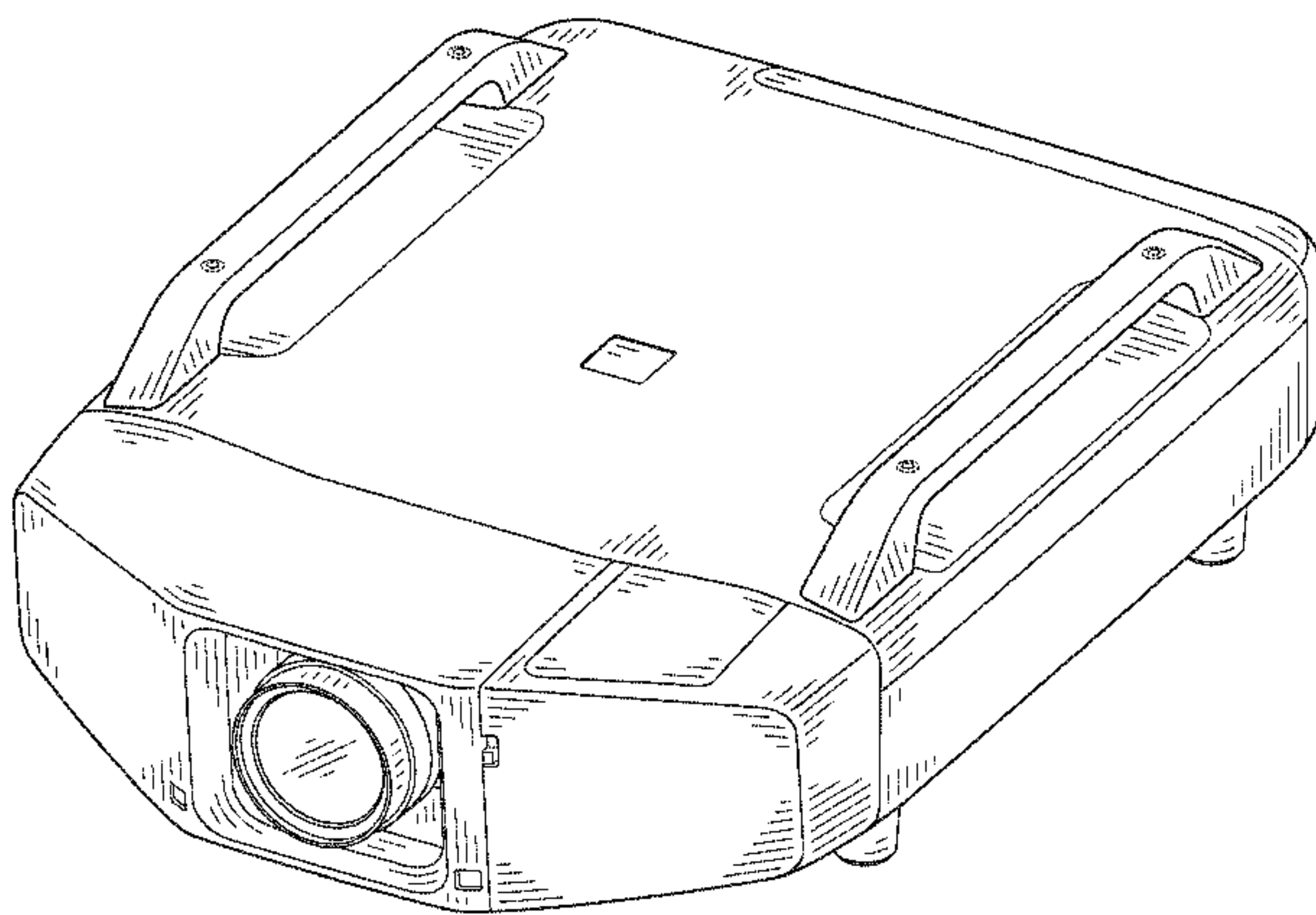

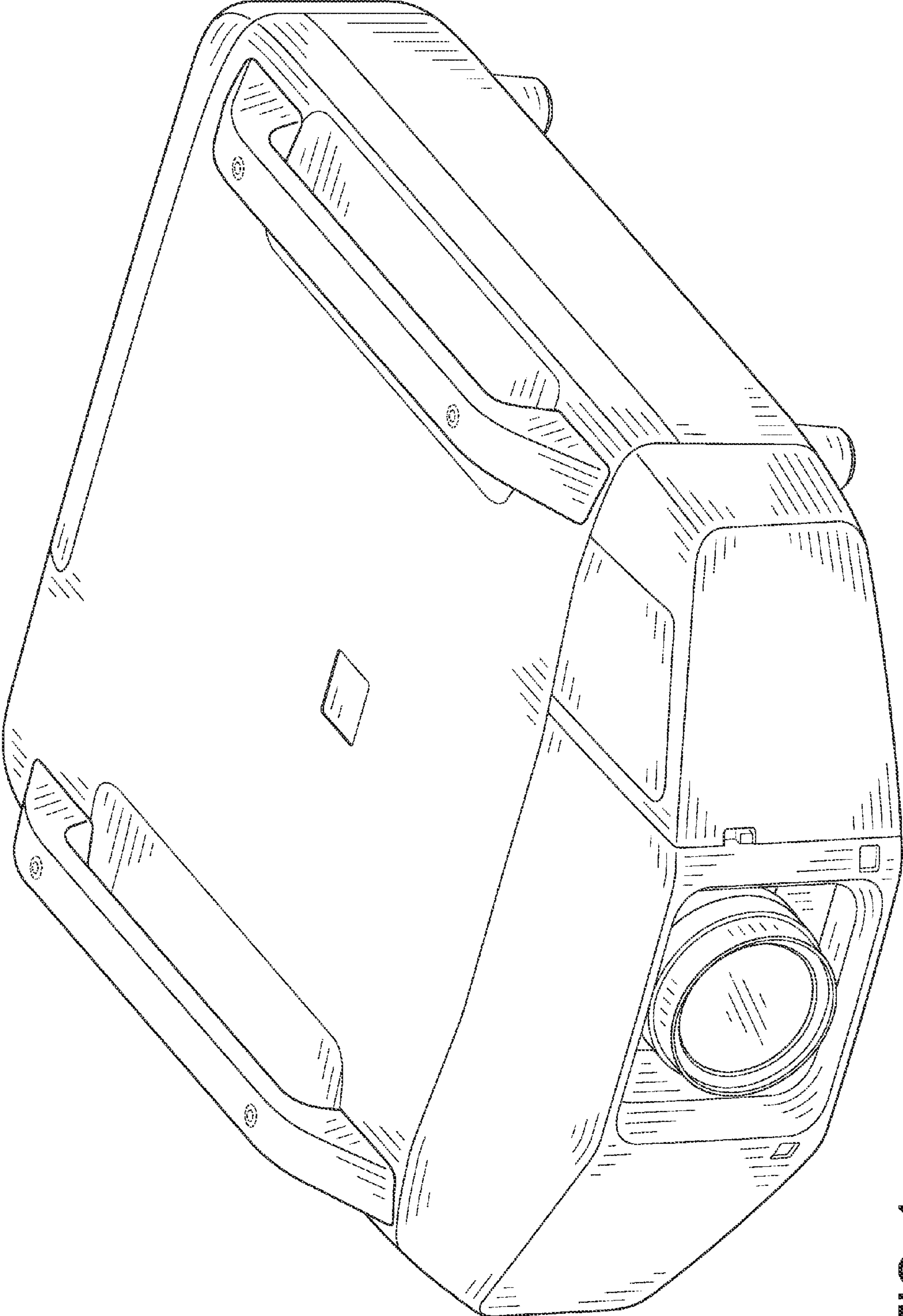

FIG. 1

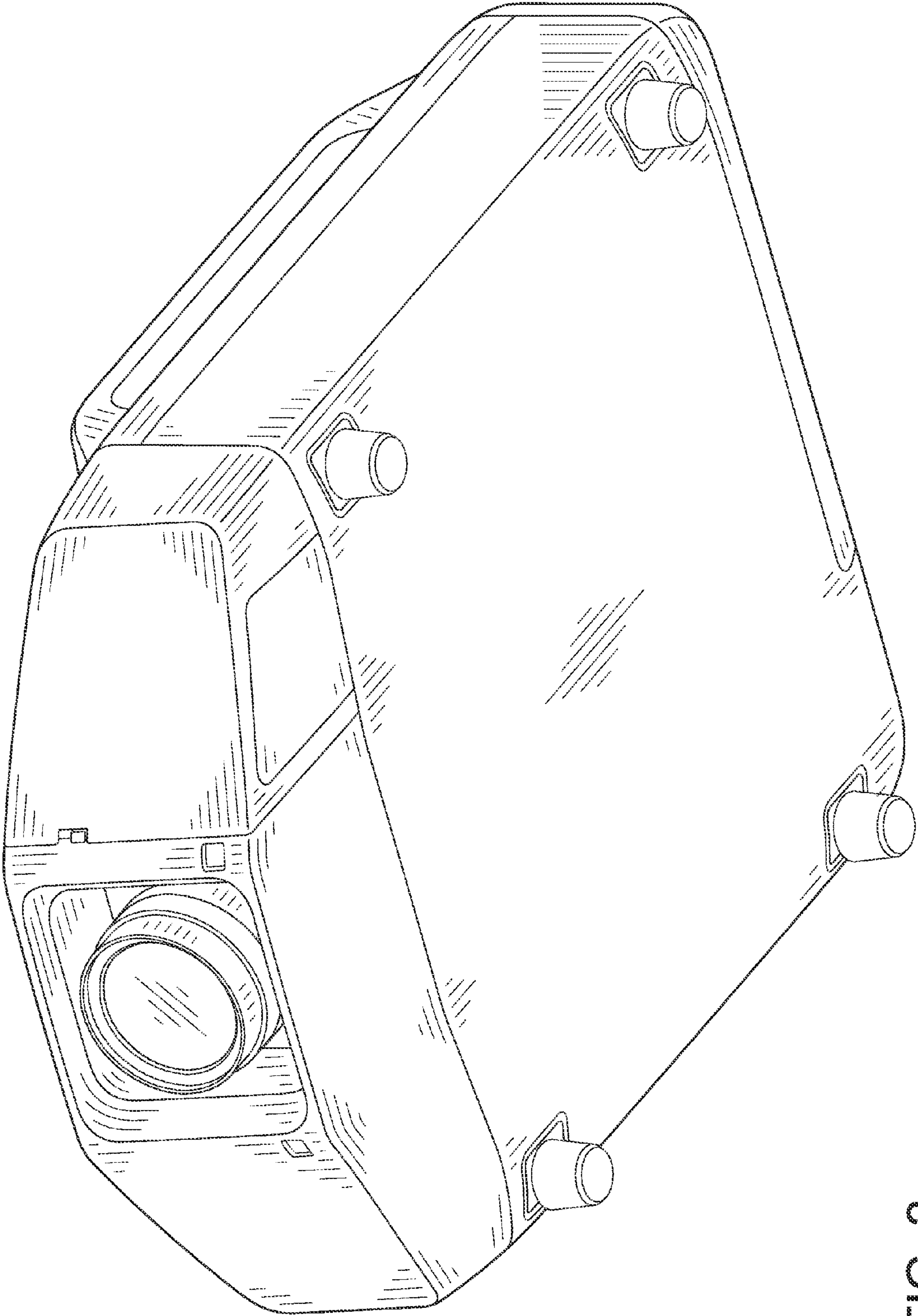

FIG. 2

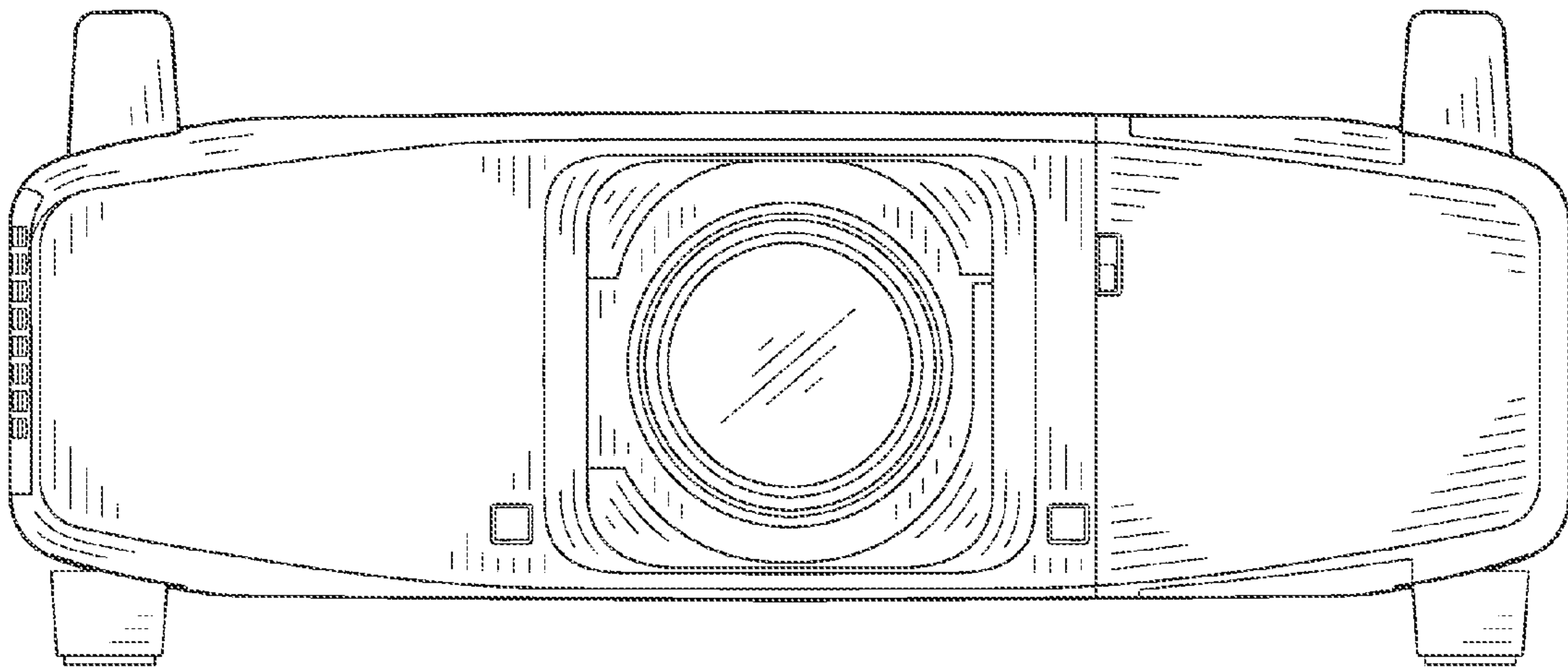

FIG. 3

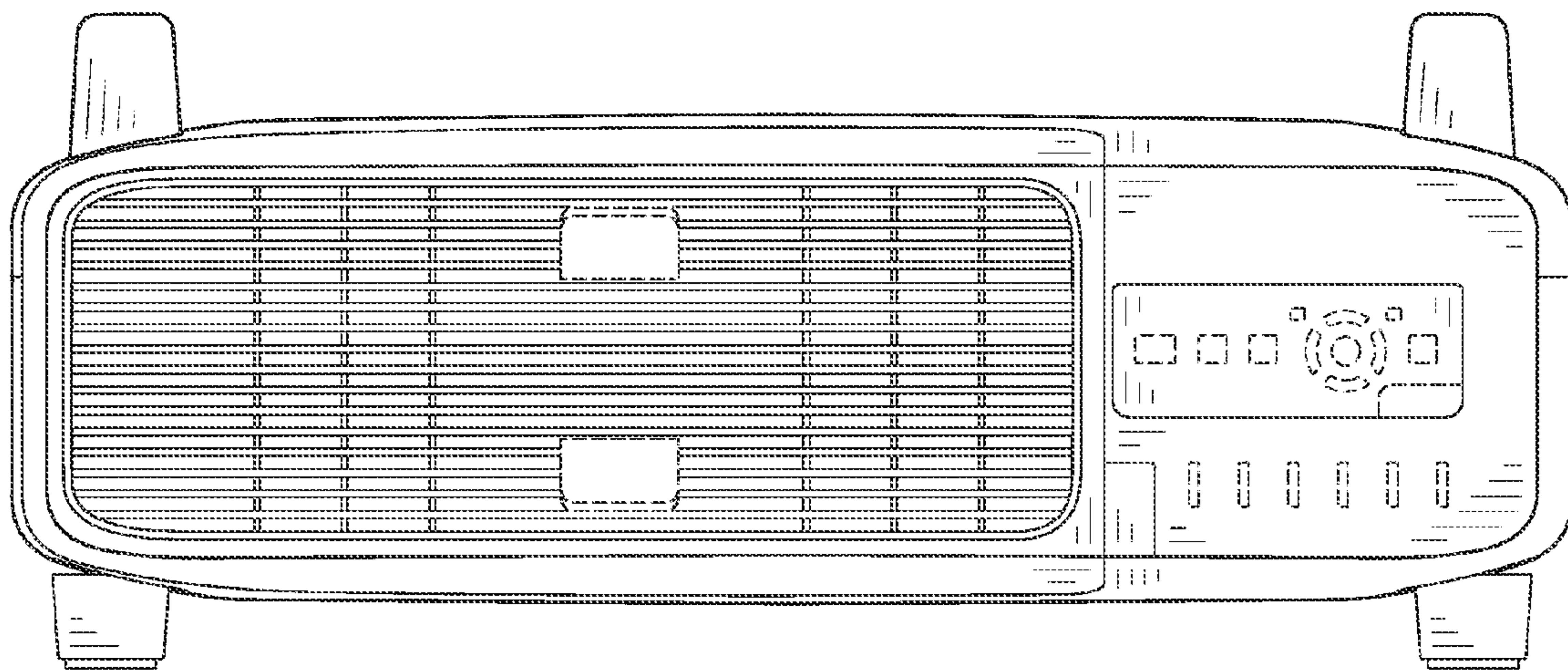

FIG. 4

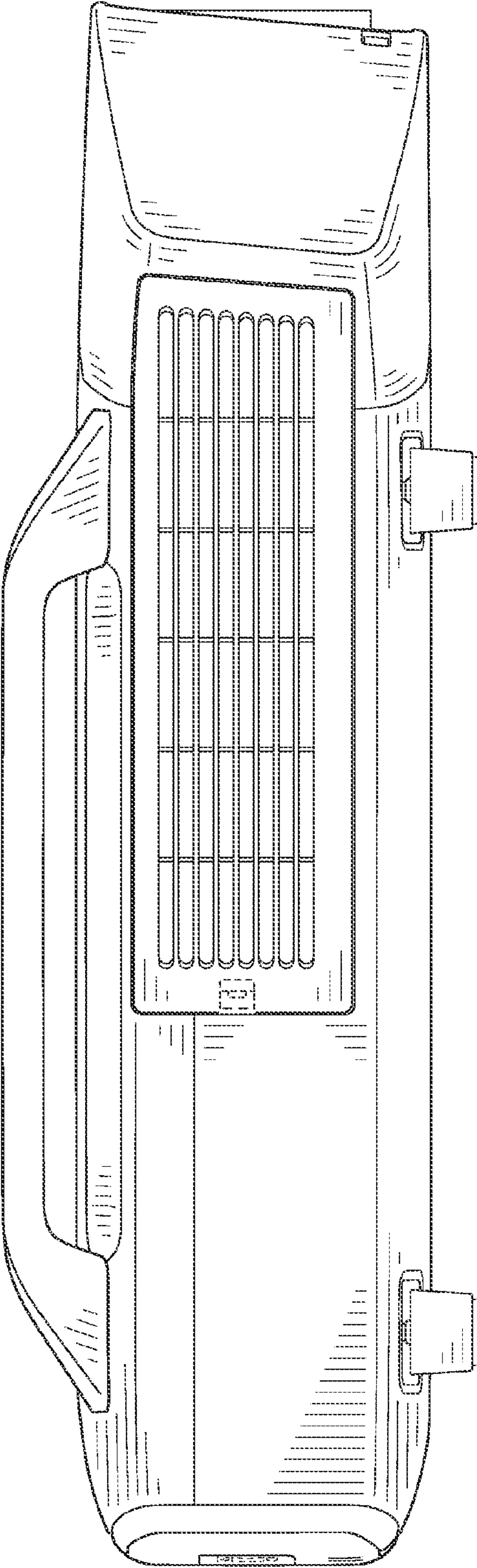

FIG. 5

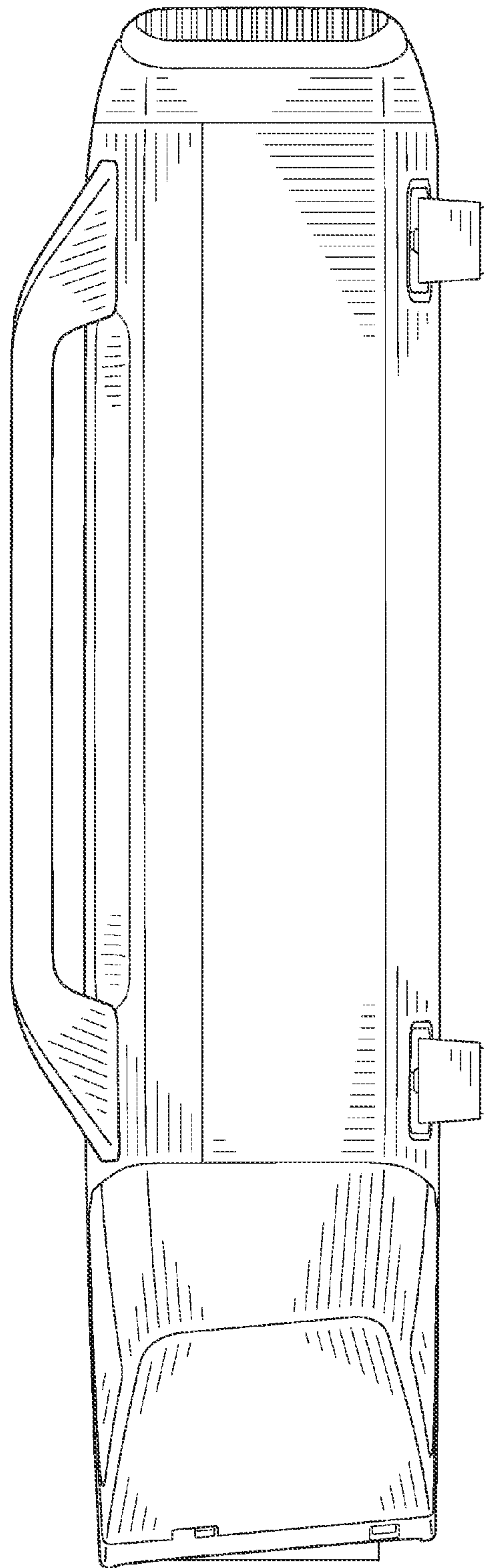

FIG. 6

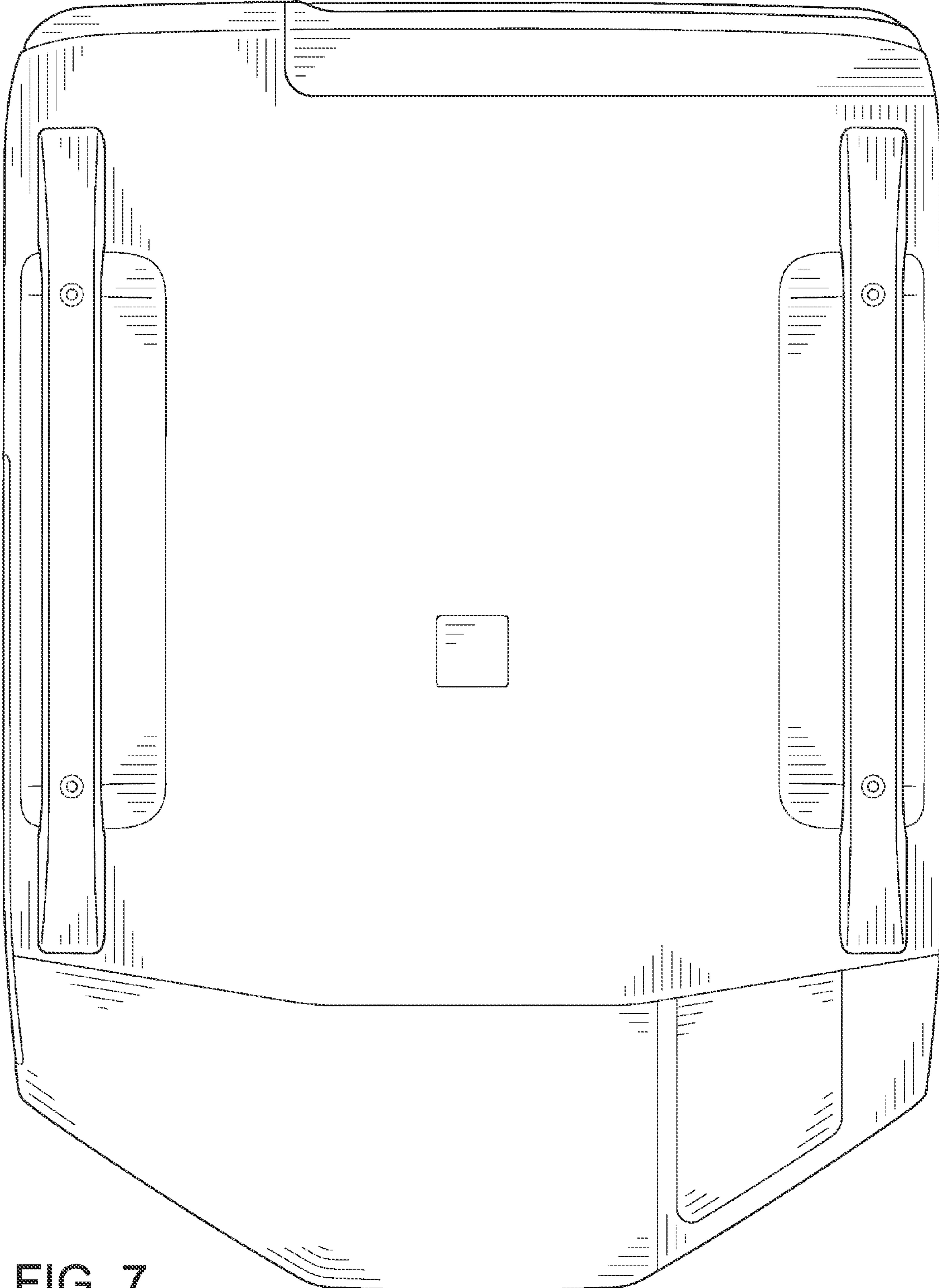

FIG. 7

FIG. 8

