



US00D617729S

(12) **United States Design Patent**
McGrath

(10) **Patent No.:** **US D617,729 S**
(45) **Date of Patent:** **** Jun. 15, 2010**

(54) **VALVE STEM CAP**

D491,519 S * 6/2004 Thieme D12/607

(76) Inventor: **Andrew H. McGrath**, 1281 Franquette Ave., Suite A, Concord, CA (US) 94520

* cited by examiner

(**) Term: **14 Years**

Primary Examiner—Stacia Cadmus

(74) *Attorney, Agent, or Firm*—Charles L. Thoeming

(21) Appl. No.: **29/356,956**

(57) **CLAIM**

(22) Filed: **Mar. 4, 2010**

The ornamental design for a valve stem cap, as shown and described.

(51) **LOC (9) Cl.** **12-15**

(52) **U.S. Cl.** **D12/607**

(58) **Field of Classification Search** D12/606–607;
D8/310; D9/300, 450, 445–446, 453; 152/427–429;
280/159, 847; D23/260; 74/558.5; 137/232;
139/89.1–89.4

See application file for complete search history.

DESCRIPTION

FIG. 1 is a perspective view from above of a valve stem cap in a pneumatic tire environment showing my new design.

FIG. 2 is a perspective view from below of a valve stem cap showing my new design.

FIG. 3 is a top view of the valve stem cap of FIG. 2.

FIG. 4 is a front/side view of the valve stem cap of FIG. 2; a rear view of the valve stem cap of FIG. 2 is the mirror image of FIG. 4, and an opposite side view of the valve stem cap of FIG. 2 is the mirror image of FIG. 4; and,

FIG. 5 is a bottom view of the of the valve stem cap of FIG. 2.

The broken line showing of the tire valve stem is included for the purpose of illustrating environment and forms no part of the claimed design.

(56) **References Cited**

U.S. PATENT DOCUMENTS

- D53,172 S * 4/1919 Woodbury D12/607
- D201,606 S * 7/1965 McCord D12/607
- D216,353 S * 12/1969 Nelson D12/607
- D449,259 S * 10/2001 Sheu D12/607
- D449,805 S * 10/2001 Sheu D12/607
- D485,804 S * 1/2004 Lewis D12/607

1 Claim, 1 Drawing Sheet

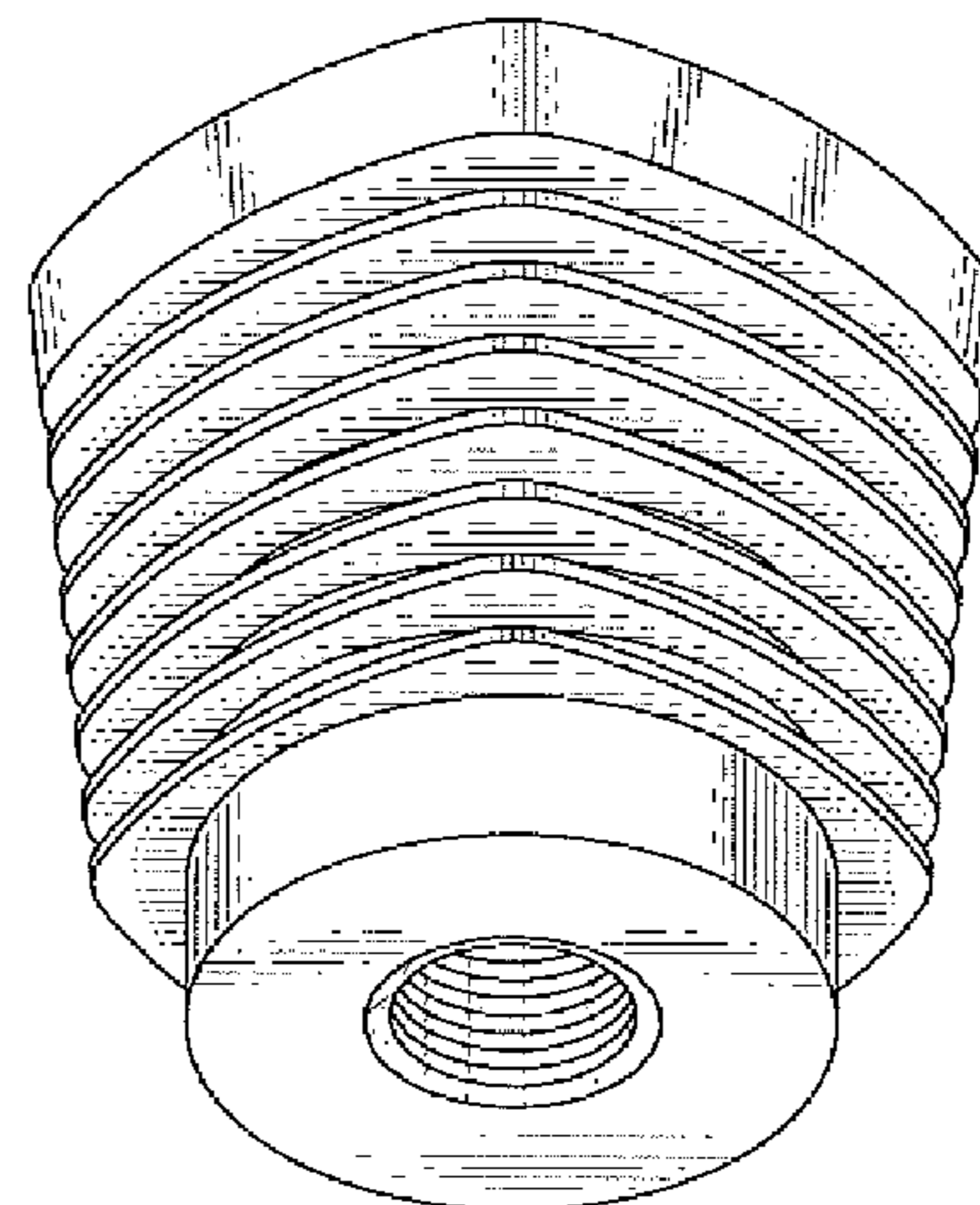
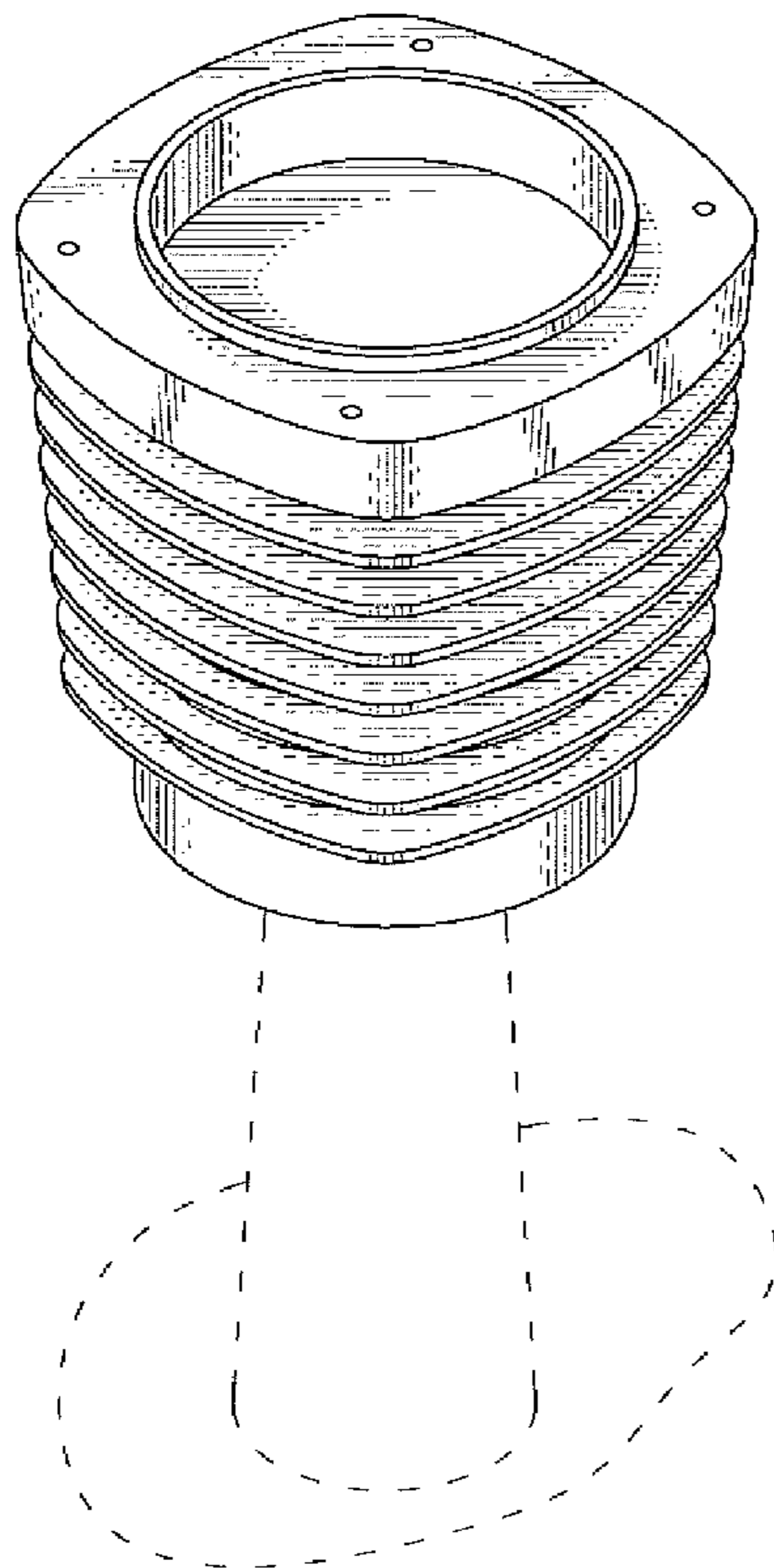

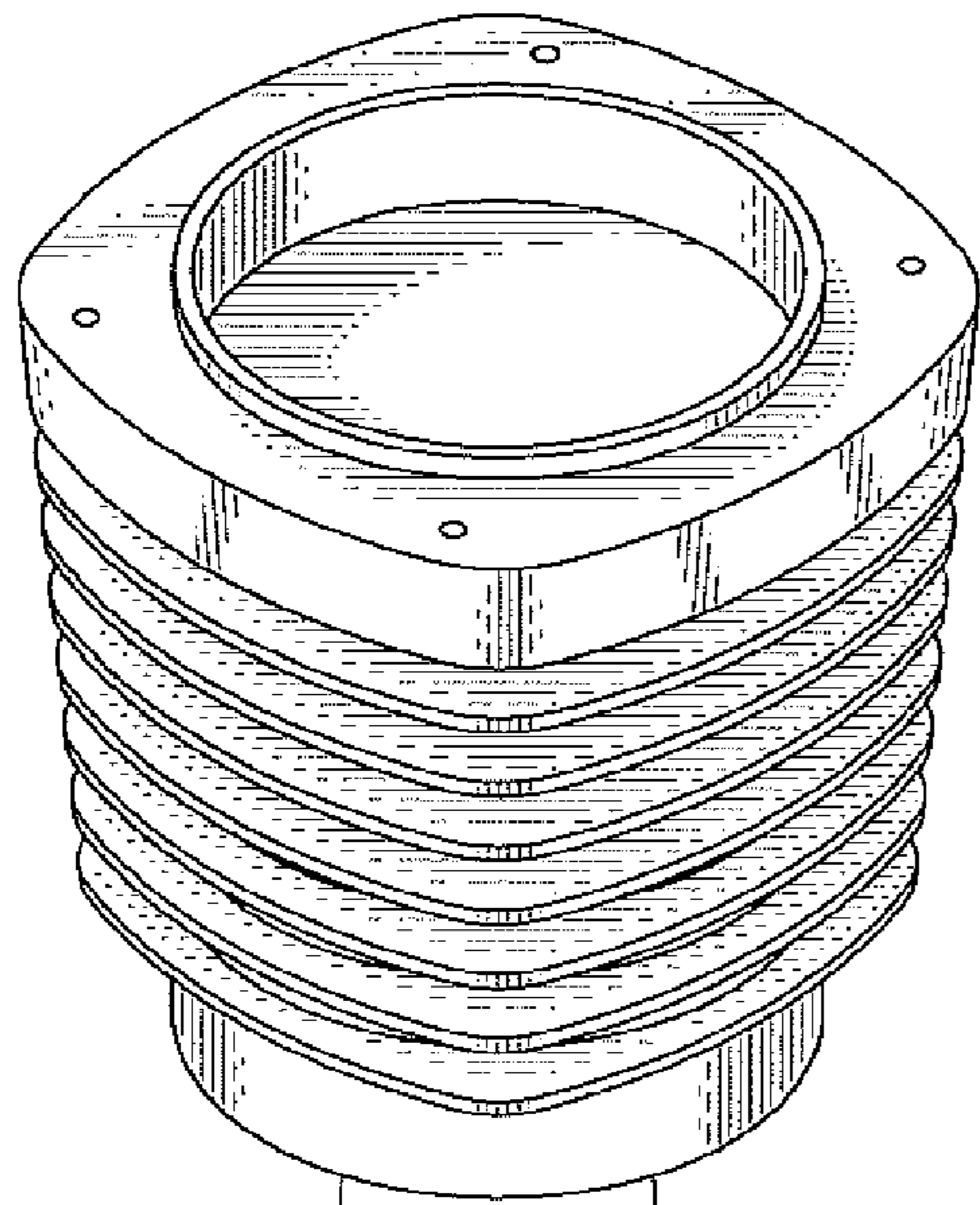

Fig. 1

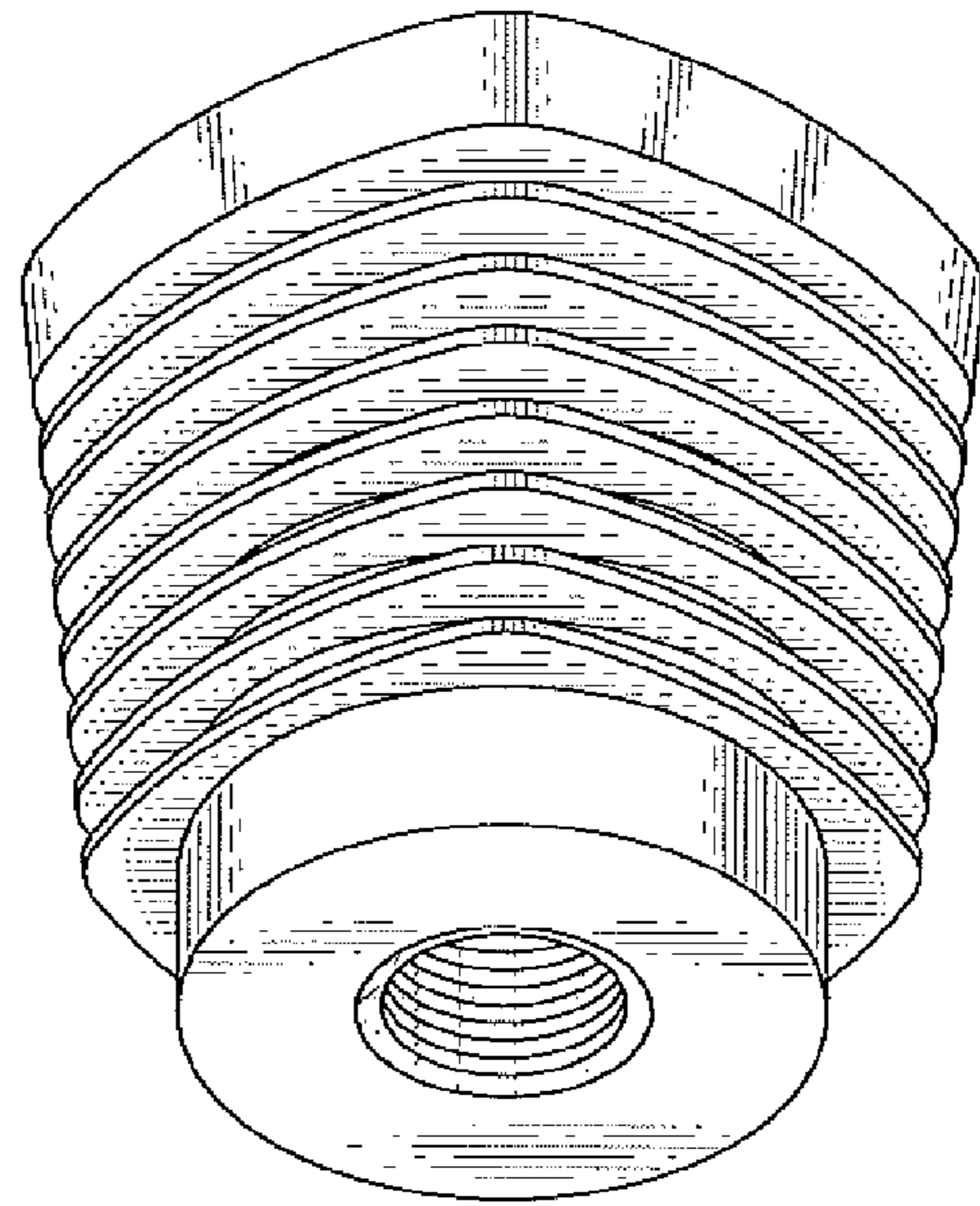

Fig. 2

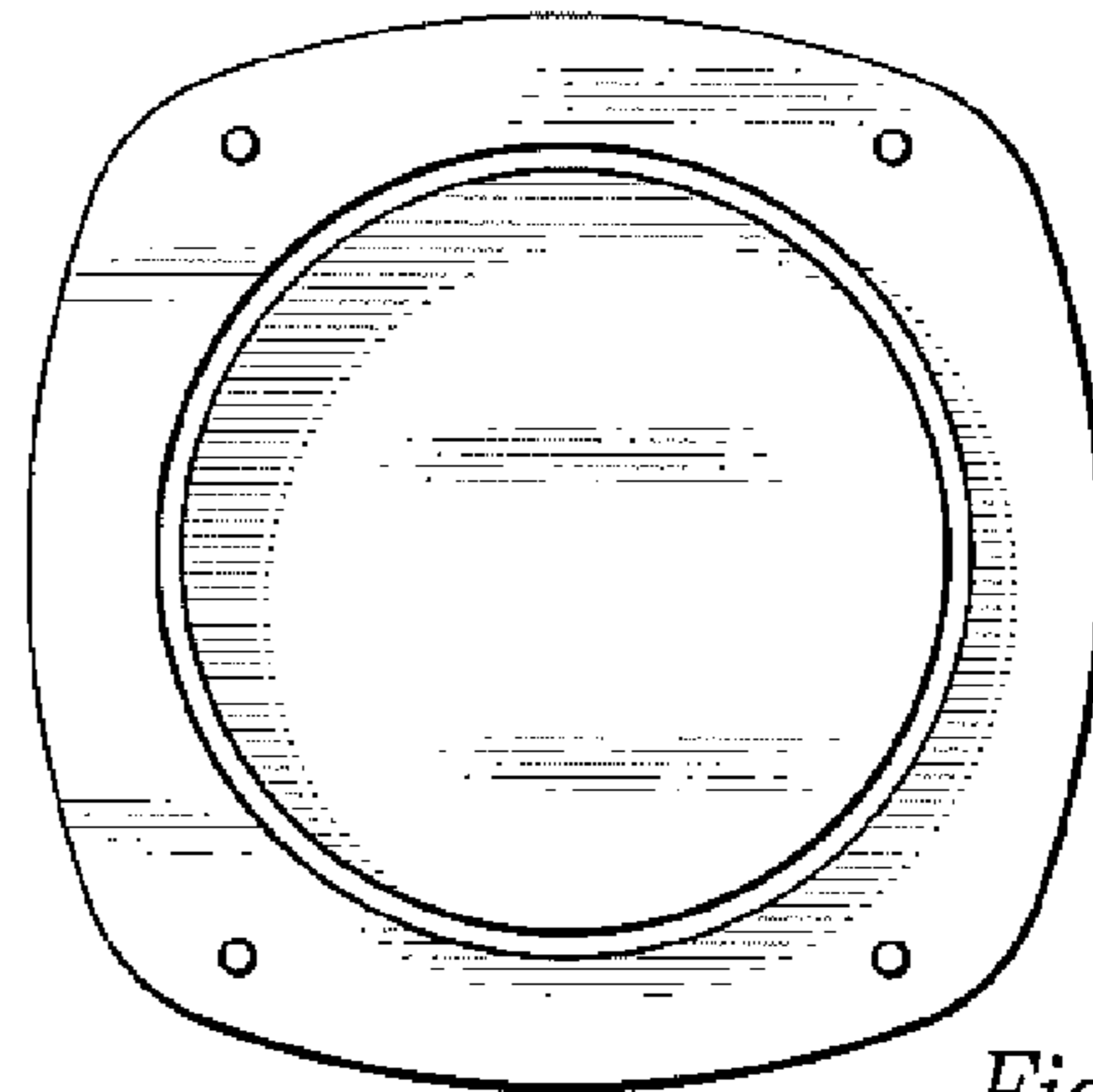
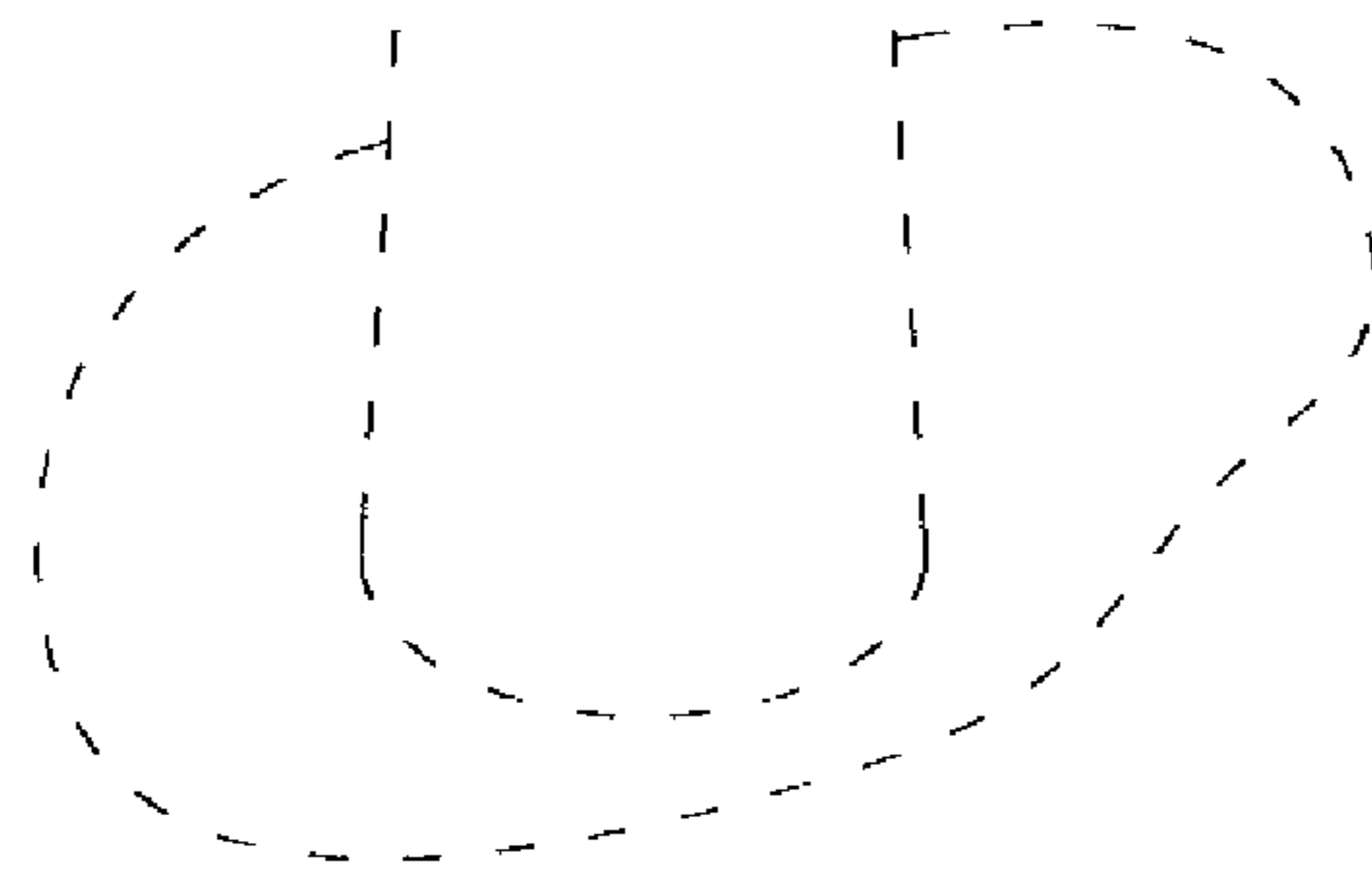

Fig. 3

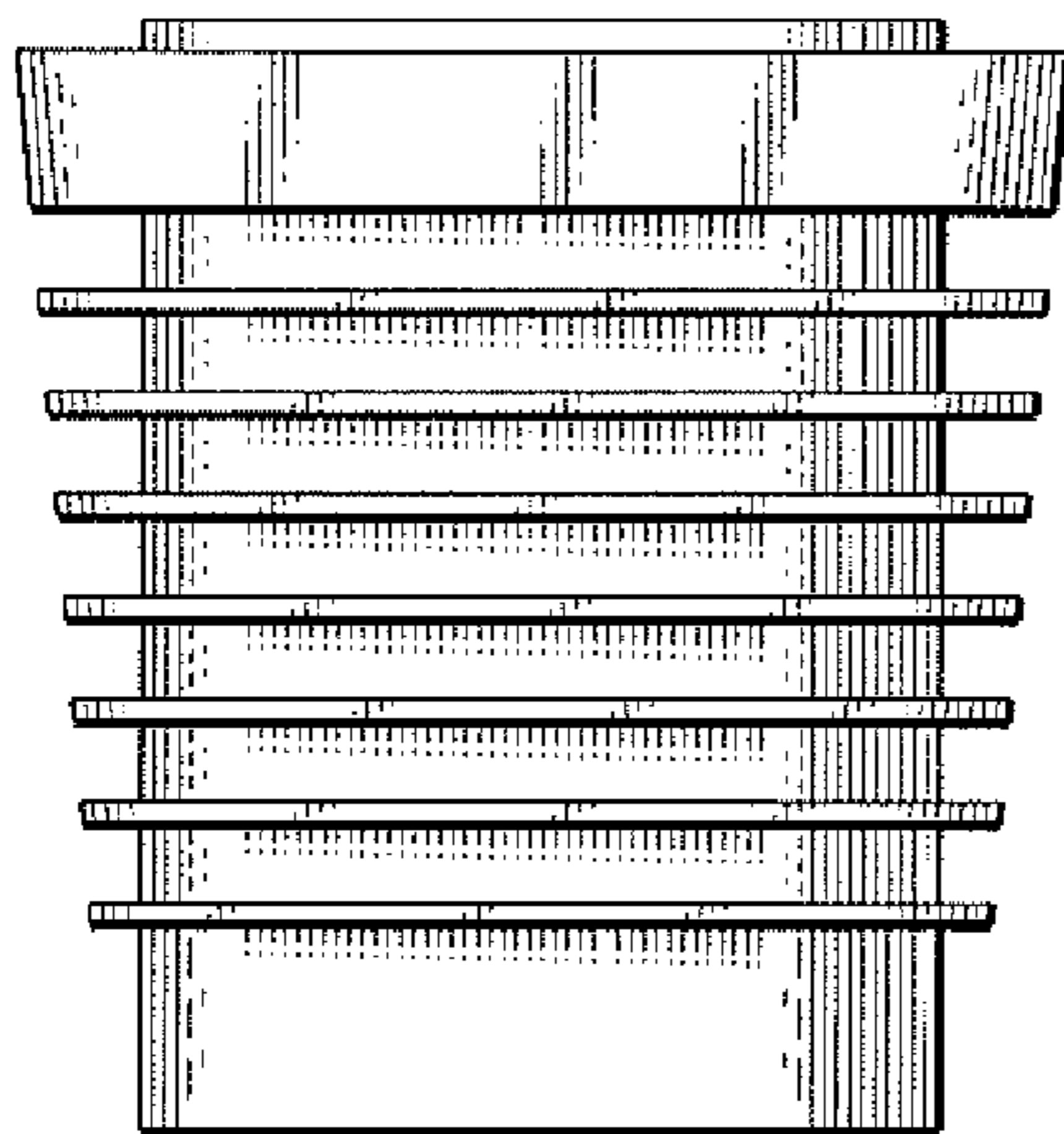

Fig. 4

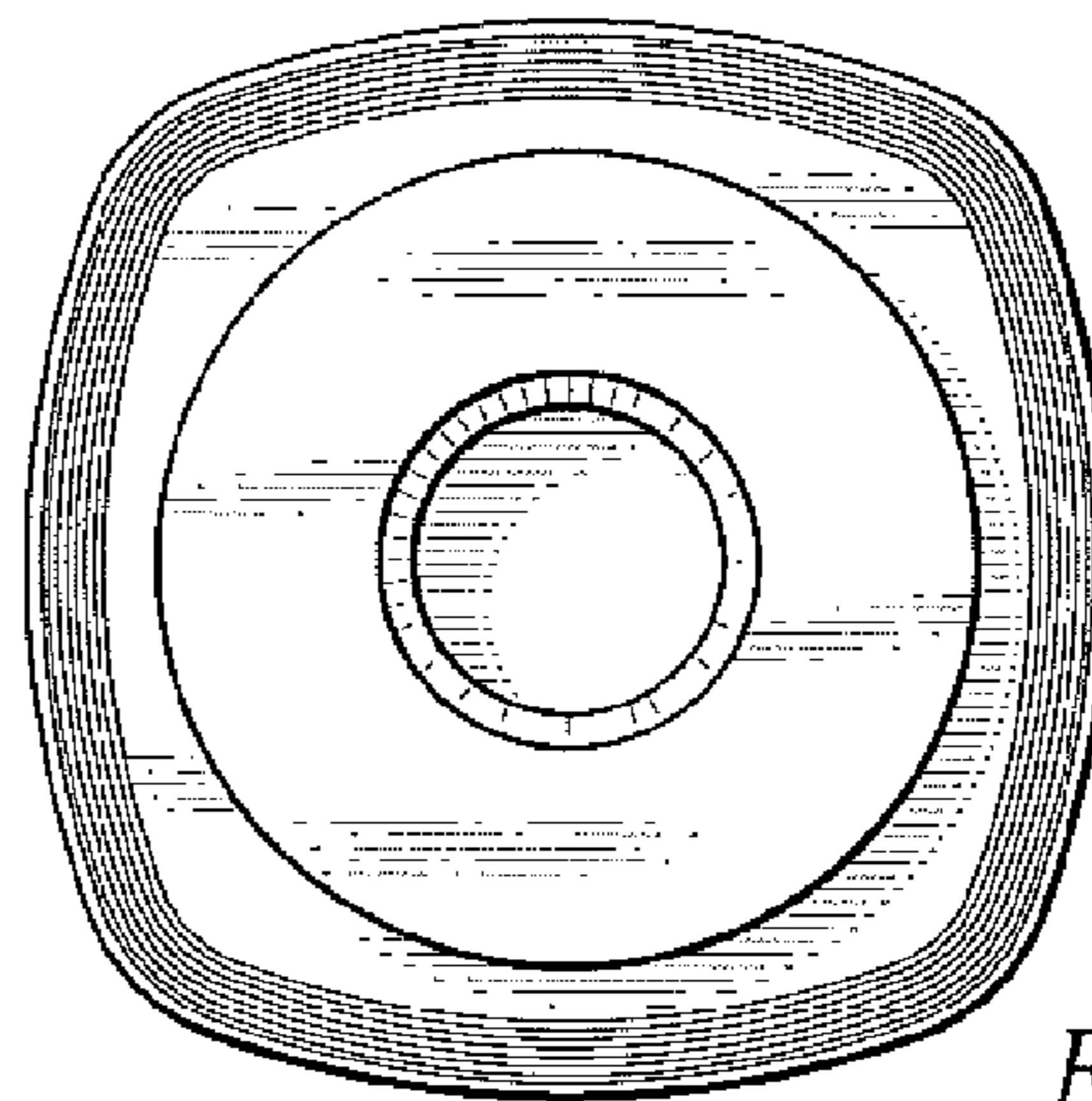

Fig. 5