



US00D617724S

(12) **United States Design Patent**
Saint-Jalmes et al.

(10) **Patent No.:** **US D617,724 S**
(45) **Date of Patent:** **** Jun. 15, 2010**

(54) **AIRCRAFT**

(75) Inventors: **Bruno Saint-Jalmes**, Toulouse (FR);
Jason Zaneboni, Blagnac (FR);
Bernard Rumeau, Cornebarrieu (FR)

(73) Assignee: **Airbus SAS**, Blagnac Cedex (FR)

(**) Term: **14 Years**

(21) Appl. No.: **29/335,123**

(22) Filed: **Apr. 9, 2009**

(51) **LOC (9) Cl.** **12-07**

(52) **U.S. Cl.** **D12/343**

(58) **Field of Classification Search** D12/319,
D12/337, 340-343, 345; 244/12.1, 13, 15,
244/45 A, 45 R; D21/447, 448; 446/36
See application file for complete search history.

(56) **References Cited**

U.S. PATENT DOCUMENTS

D172,969 S *	9/1954	Johnson et al.	D12/341
D177,029 S *	3/1956	Frost et al.	D12/340
D229,353 S *	11/1973	Fellers et al.	D10/80
D231,607 S *	5/1974	Rellis	D12/338
D370,456 S *	6/1996	Buchsel et al.	D12/340
D516,007 S *	2/2006	Vigneron et al.	D12/319
D530,658 S *	10/2006	Vigneron et al.	D12/319
D541,207 S *	4/2007	Seidel	D12/343
D582,832 S *	12/2008	Dornier	D12/337

OTHER PUBLICATIONS

Q400 NextGen, Bombardier [online], 1997-2008, [retrieved on Aug. 4, 2009]. Retrieved from the Internet: <URL: <http://www.q400.com/q400/en/home.jsp>>.

Turbo Prop Airliner Production List; J Roach, A.B. Eastwood [online], [retrieved on Aug. 4, 2009]. Retrieved from the Internet: <URL: <http://www.tahts.com/books/turbo.htm>>.

ATR Pictures Media Gallery, ATR GIE [online], 2008 [retrieved on Aug. 4, 2009]. Retrieved from the Internet: <URL: <http://www.atr.fr/public/atr/html/media/pictures.php>>.

* cited by examiner

Primary Examiner—Cathron C. Brooks

Assistant Examiner—Maurice Stevens

(74) *Attorney, Agent, or Firm*—Osler, Hoskin & Harcourt LLP

(57) **CLAIM**

The ornamental design for an aircraft, as shown and described.

DESCRIPTION

FIG. 1 is a front, left perspective view showing an aircraft according to our design;

FIG. 2 is a left side elevation view thereof;

FIG. 3 is a right side elevation view thereof;

FIG. 4 is a top plan view thereof;

FIG. 5 is a bottom plan view thereof;

FIG. 6 is a front elevation view thereof;

FIG. 7 is a rear elevation view thereof;

FIG. 8 is a rear, left perspective view thereof; and,

FIG. 9 is a front, left perspective view of the aircraft of FIG. 1 shown with propellers in broken lines.

Throughout the Figures, broken lines showing environment or structure are for illustrative purposes only and form no part of the claimed design.

1 Claim, 9 Drawing Sheets

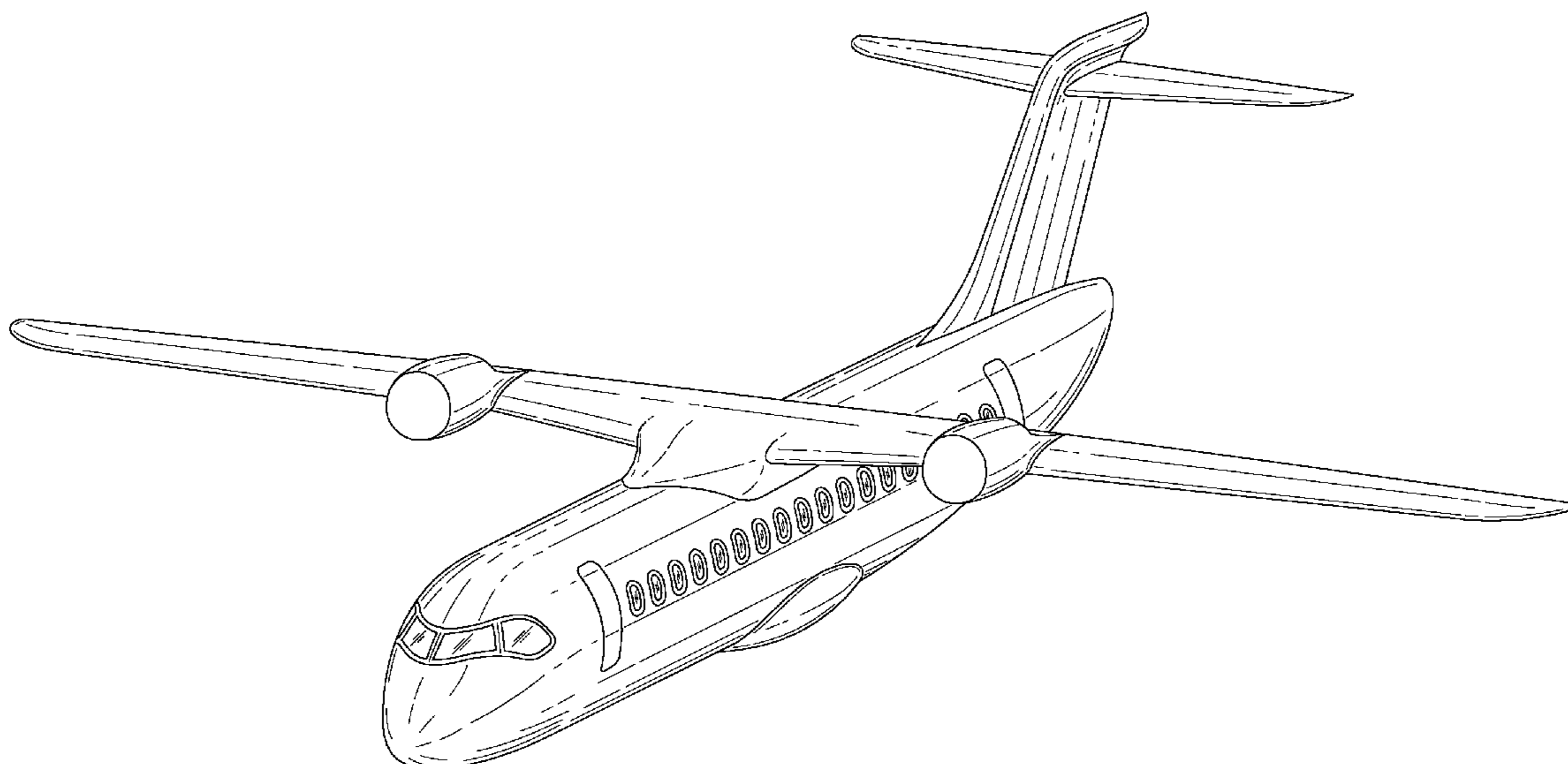

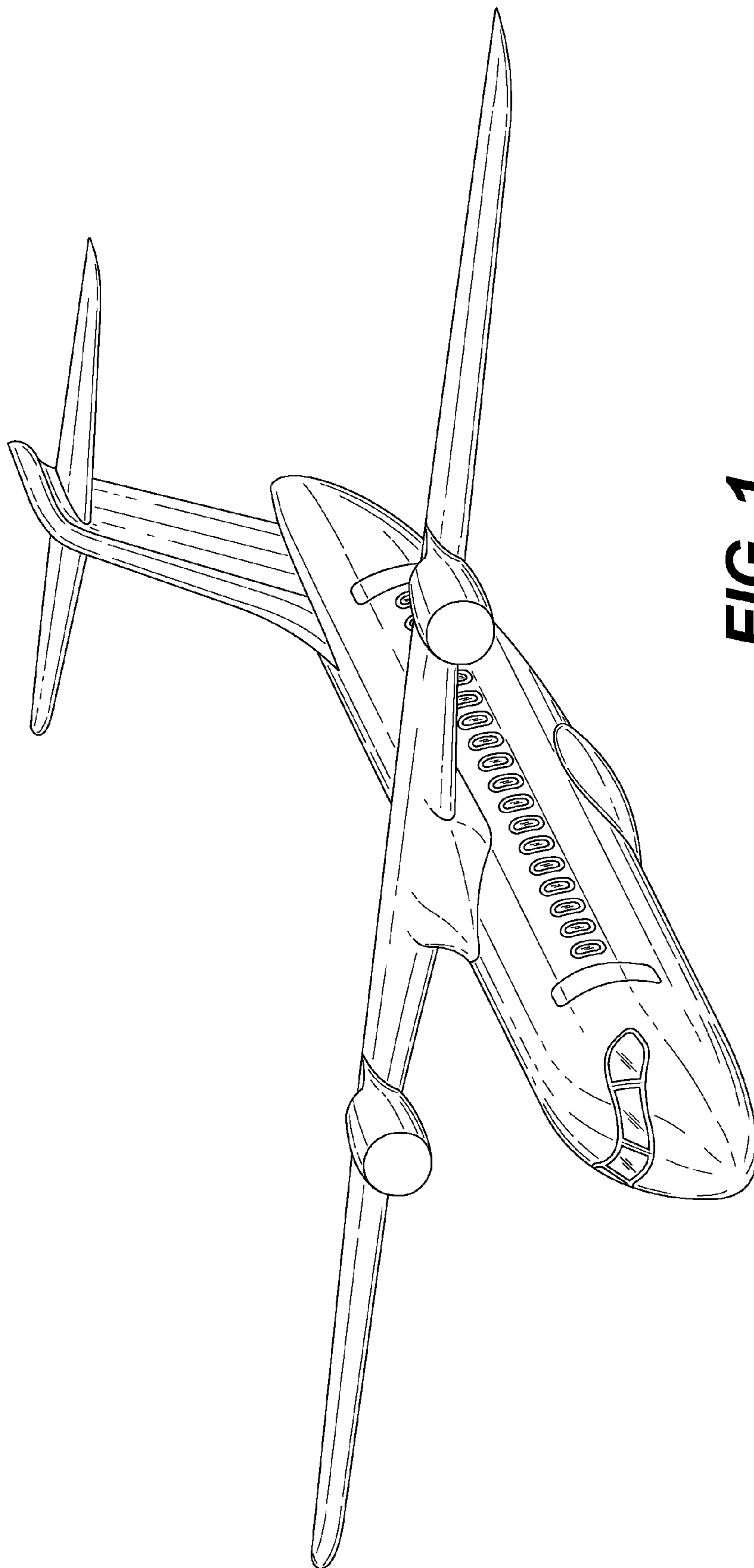

FIG. 1

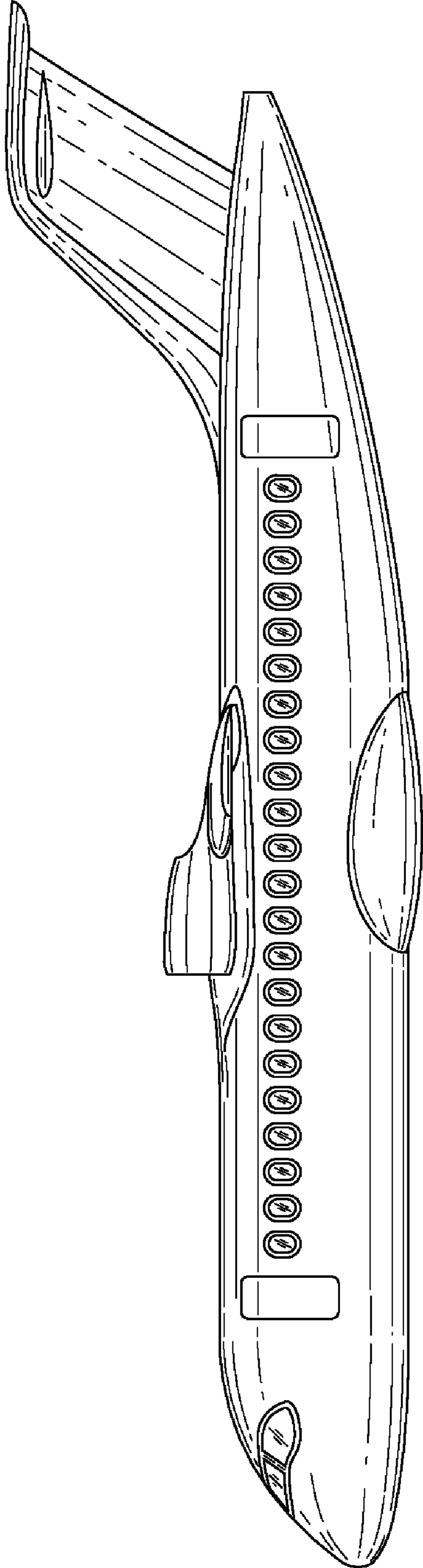

FIG. 2

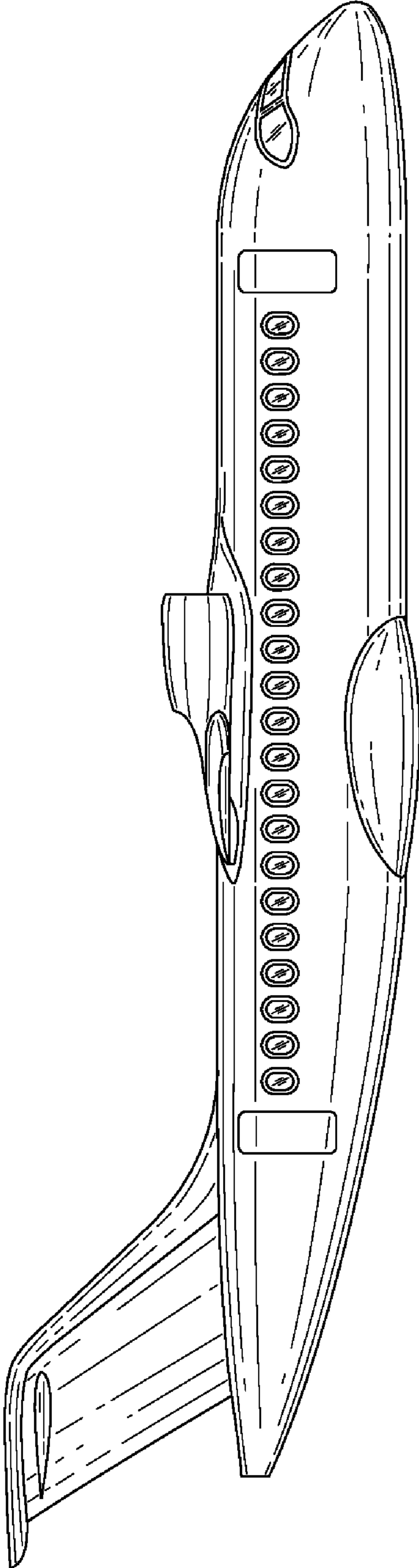

FIG. 3

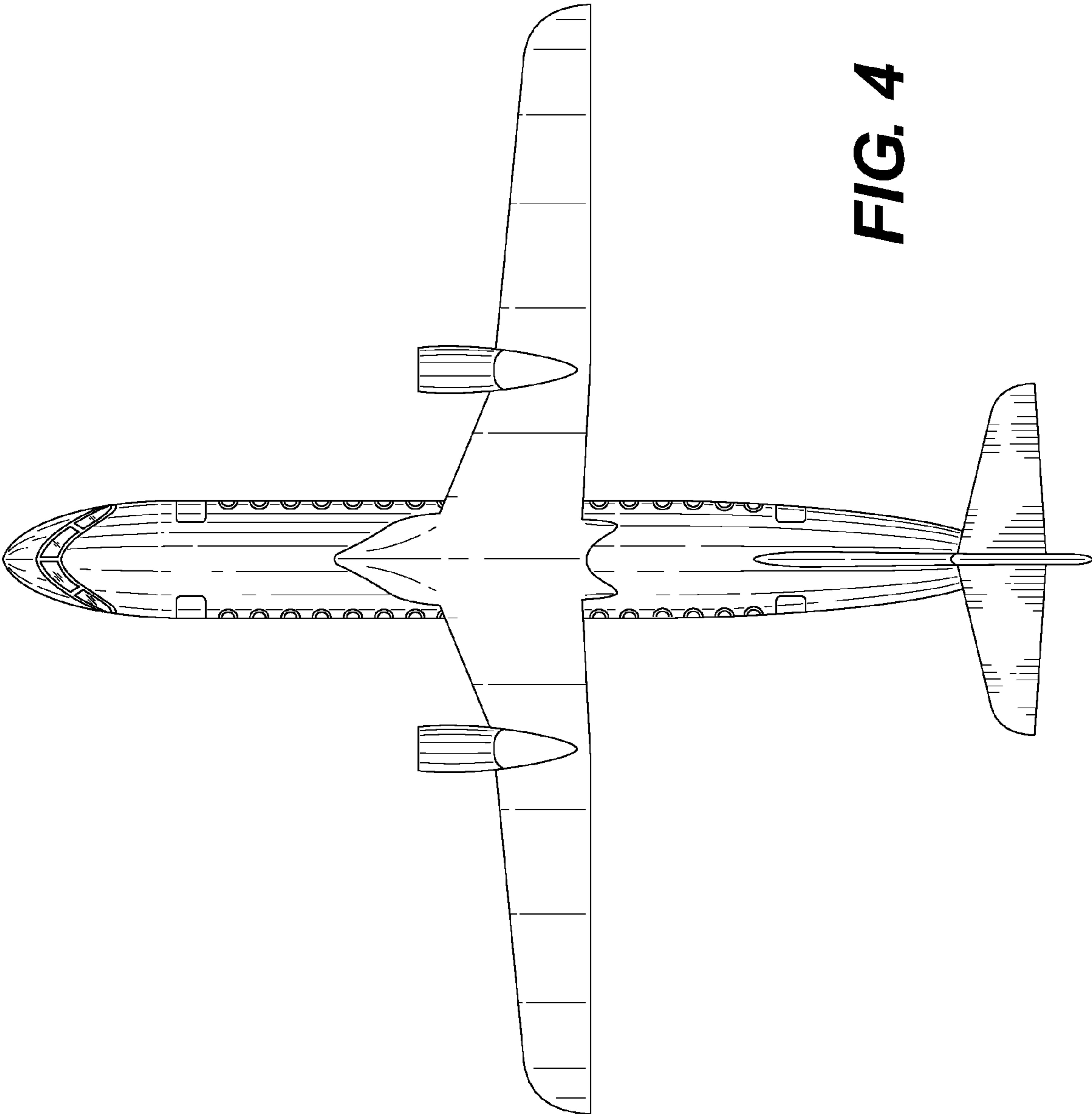

FIG. 4

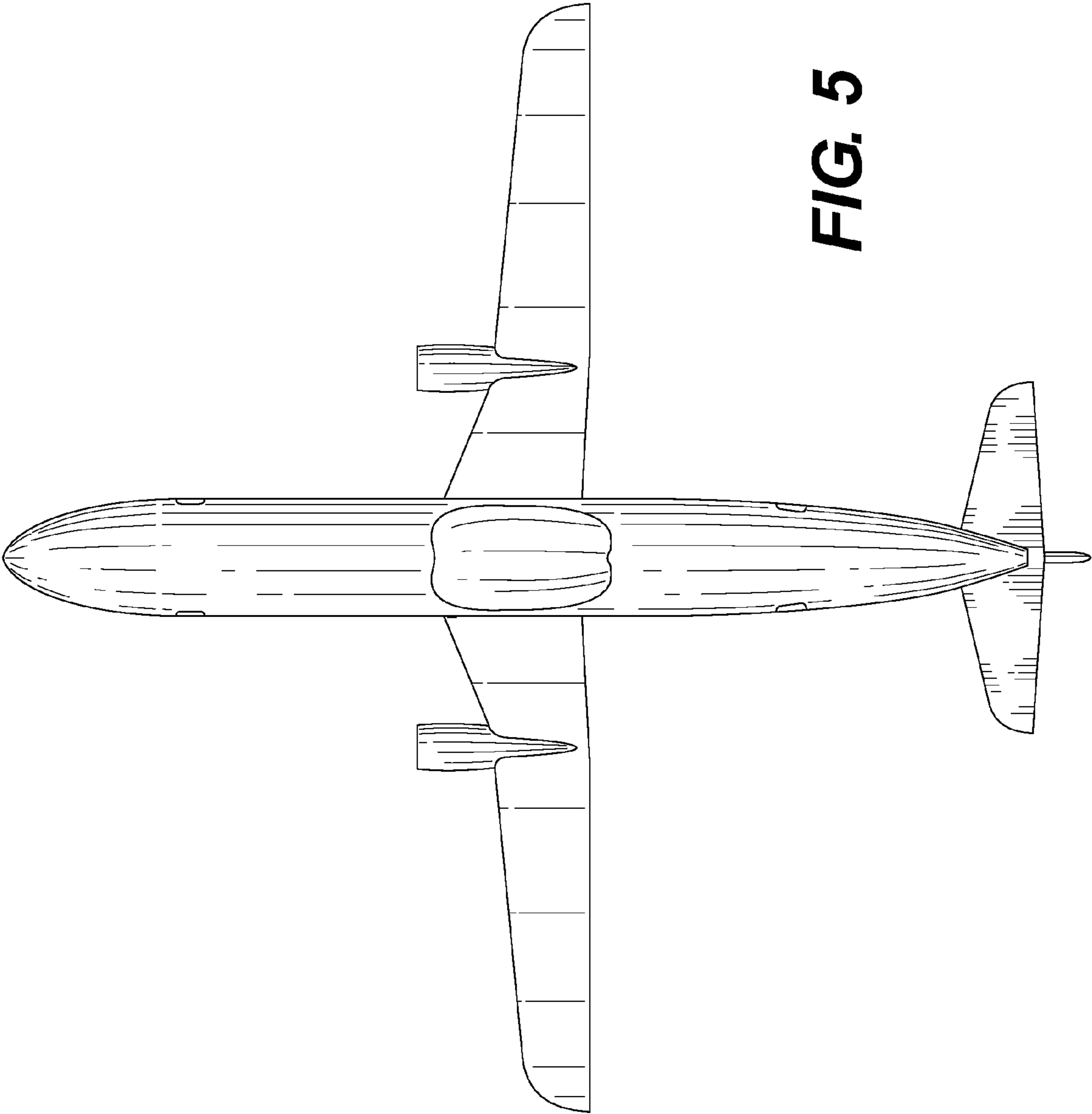

FIG. 5

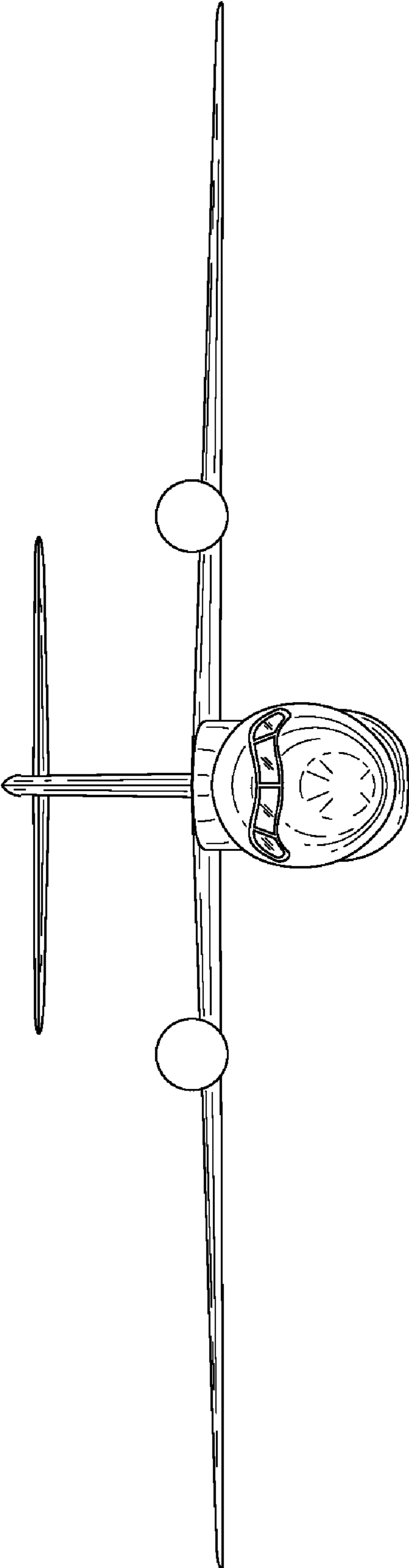

FIG. 6

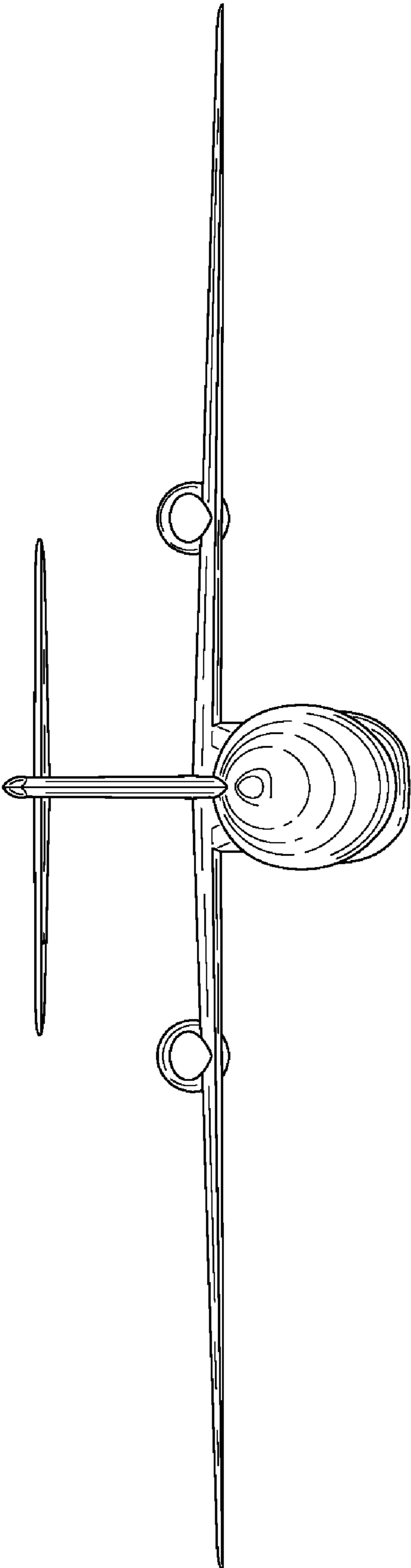

FIG. 7

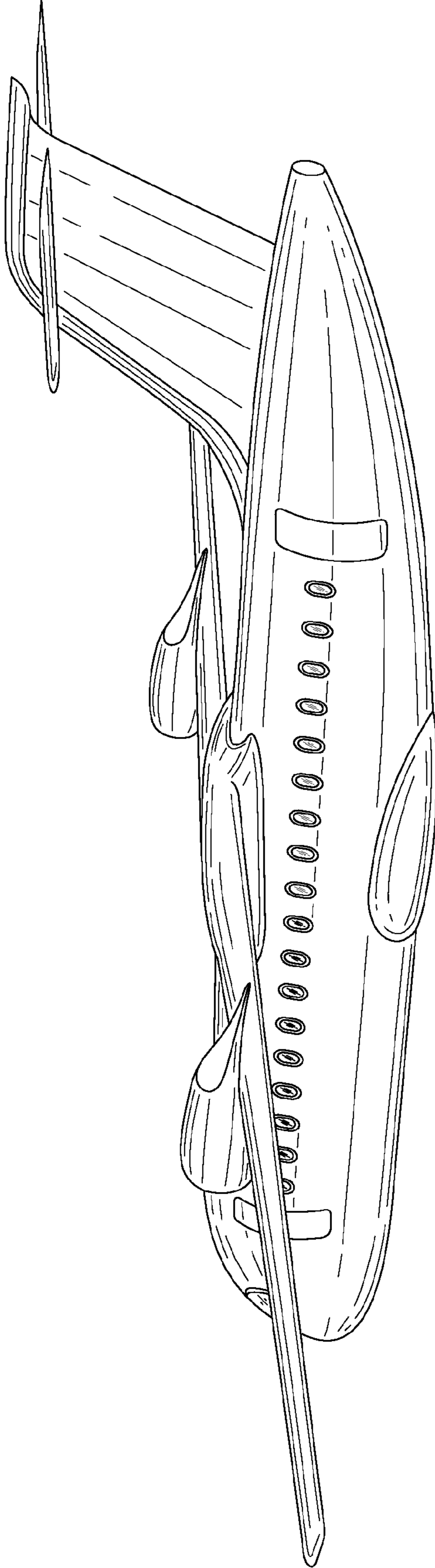

FIG. 8

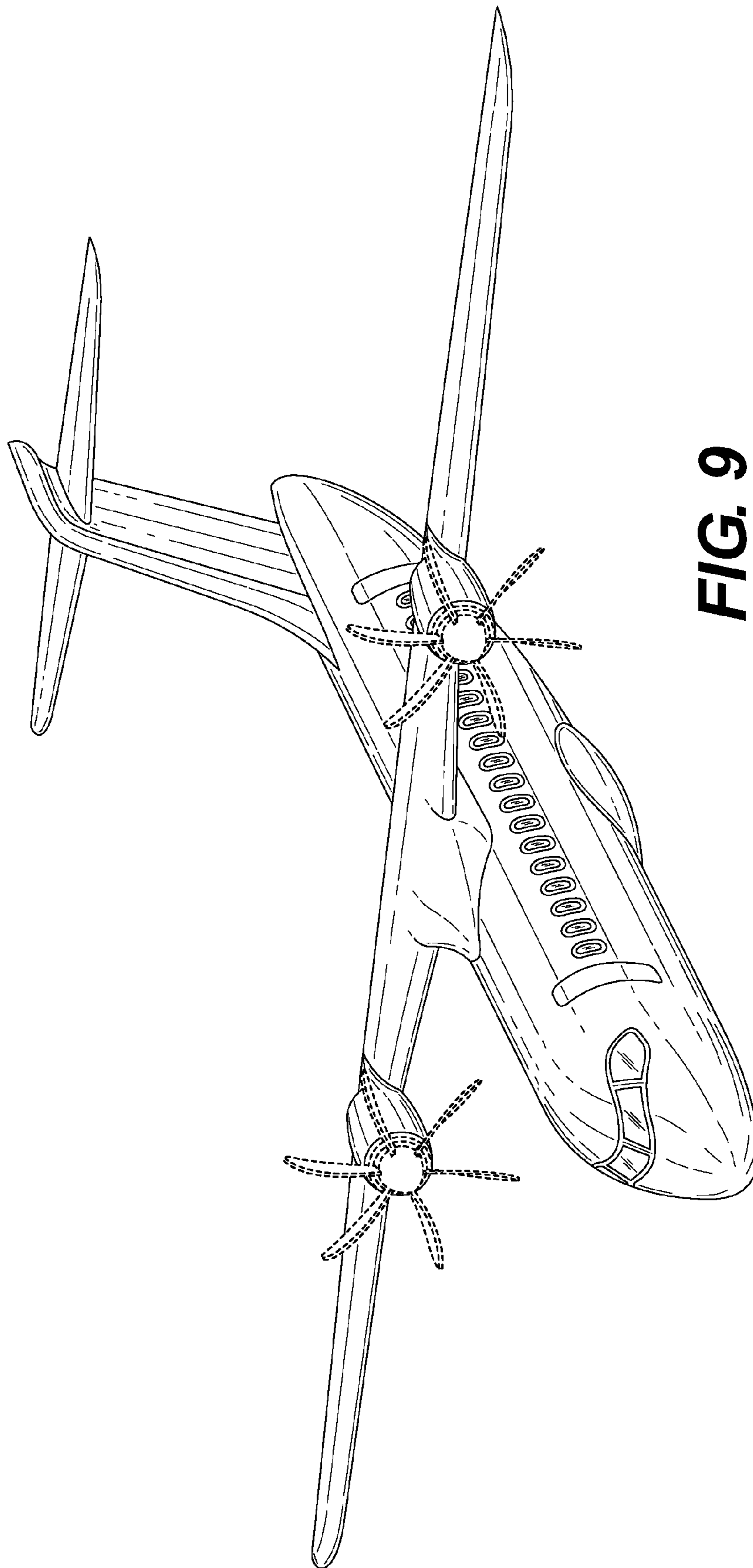

FIG. 9