



US00D617704S

(12) **United States Design Patent**
Bauer et al.

(10) **Patent No.:** **US D617,704 S**
(45) **Date of Patent:** **** Jun. 15, 2010**

(54) **FOOT FOR A SIDE MIRROR FOR A VEHICLE**

(75) Inventors: **Karlheinz Bauer**, Esslingen (DE);
Ulrich Baur, Stuttgart (DE);
Hans-Dieter Futschik, Gechingen (DE);
Steffen Koehl, Stuttgart (DE);
Karl-Heinz Naegele, Bondorf (DE)

(73) Assignee: **Daimler AG**, Stuttgart (DE)

(**) Term: **14 Years**

(21) Appl. No.: **29/311,362**

(22) Filed: **Mar. 3, 2009**

(30) **Foreign Application Priority Data**
Sep. 4, 2008 (DE) 402008004192

(51) **LOC (9) Cl.** **12-16**

(52) **U.S. Cl.** **D12/187**

(58) **Field of Classification Search** D12/187,
D12/188-189, 96; D6/300, 309; 359/838,
359/841, 843, 844, 868, 871, 604, 881, 514,
359/866; 248/479-483, 475.1

See application file for complete search history.

(56) **References Cited**

U.S. PATENT DOCUMENTS

D478,853	S *	8/2003	Boyer	D12/187
D575,707	S	8/2008	Futschik et al.		
D577,639	S *	9/2008	Choi et al.	D12/187
D578,047	S *	10/2008	Kaoud et al.	D12/187
D587,638	S *	3/2009	Futschik et al.	D12/187
D589,859	S *	4/2009	Golden et al.	D12/187
7,600,877	B2 *	10/2009	Behbehani	359/868
D603,774	S *	11/2009	Chen	D12/187
2002/0141085	A1 *	10/2002	Whitehead et al.	359/841
2004/0218272	A1 *	11/2004	Boddy	359/512
2005/0174645	A1 *	8/2005	Boddy et al.	359/599
2005/0254153	A1 *	11/2005	Kawanishi	359/879
2009/0086346	A1 *	4/2009	Henion	359/841
2009/0244744	A1 *	10/2009	Okamoto et al.	359/872

* cited by examiner

Primary Examiner—Caron Veynar
Assistant Examiner—Katrina A Kile
(74) *Attorney, Agent, or Firm*—Crowell & Moring LLP

(57) **CLAIM**

The ornamental design for a foot for a side mirror for a vehicle, as shown and described.

DESCRIPTION

This application contains subject matter related to the following co-pending U.S. patent applications:

U.S. patent application Ser. No. 29/309,073, filed Jun. 18, 2008;

U.S. patent application Ser. No. 29/309,775, filed Oct. 7, 2008; and

U.S. patent application Ser. No. 29/311,363, filed herewith and entitled "Side Mirror for a Vehicle".

FIG. 1 is a right perspective view of a first embodiment of a foot for a side mirror for a vehicle according to our novel design;

FIG. 2 is a left perspective view thereof;

FIG. 3 is a left side view thereof;

FIG. 4 is a right side view thereof;

FIG. 5 is a front view thereof;

FIG. 6 is a bottom view thereof; and

FIG. 7 is a top view thereof.

FIG. 8 is a right perspective view of a second embodiment of the foot for a side mirror for a vehicle according to our novel design;

FIG. 9 is a front view thereof;

FIG. 10 is a left side view thereof;

FIG. 11 is a right side view thereof;

FIG. 12 is a top view thereof; and

FIG. 13 is a bottom view thereof.

FIG. 14 is a left perspective view of a third embodiment of the foot for a side mirror for a vehicle according to our novel design;

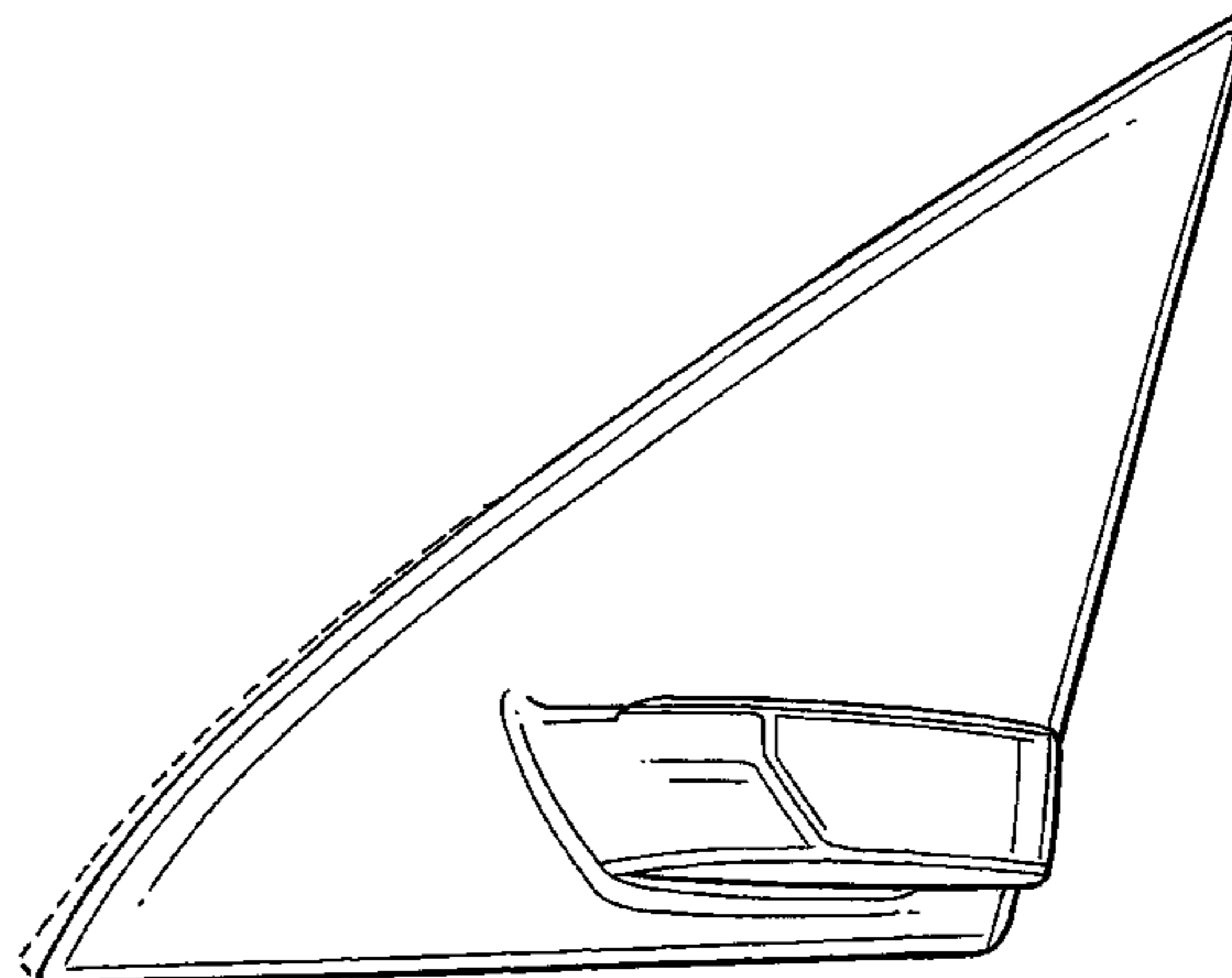
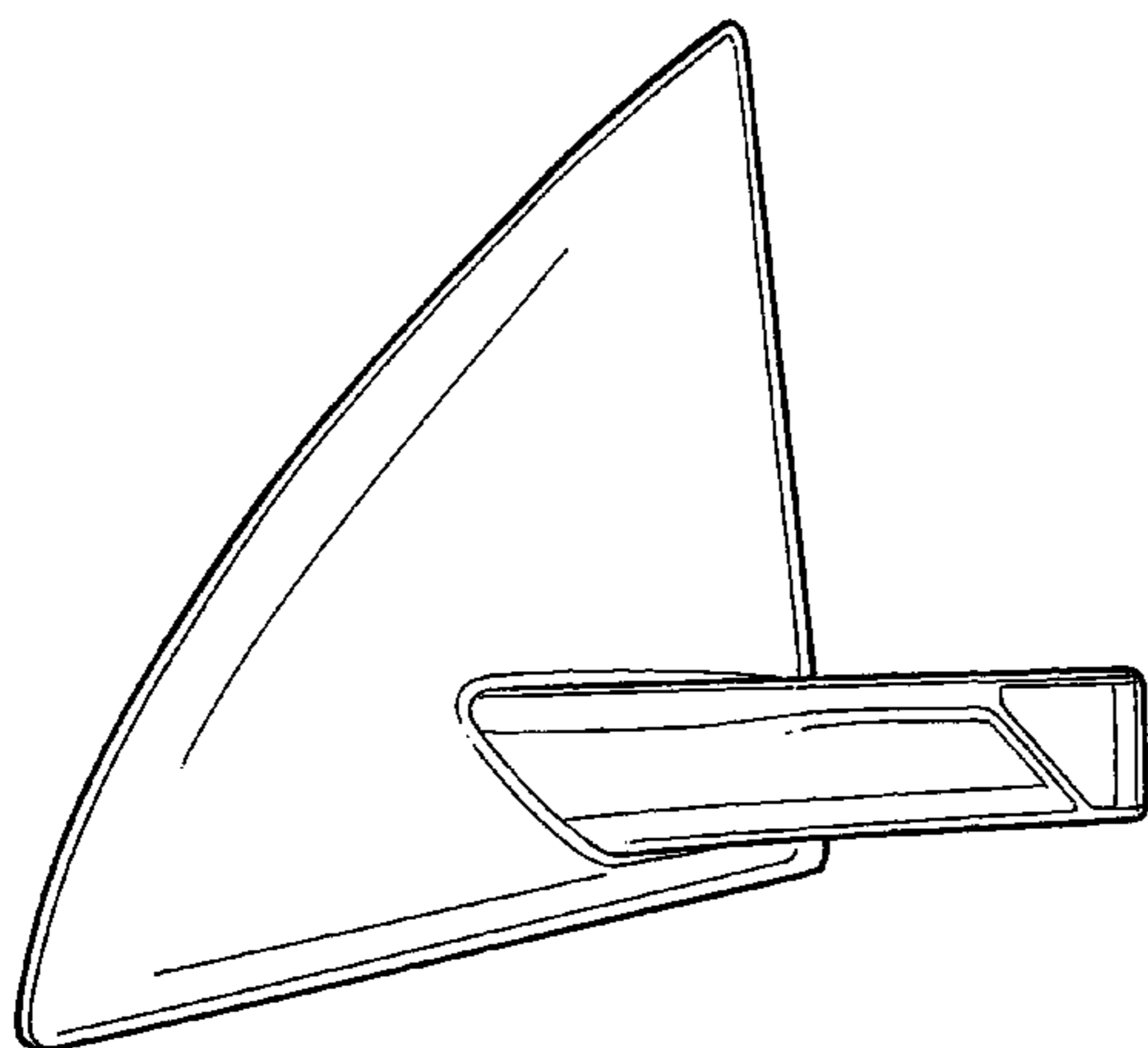

FIG. **15** is a right perspective view thereof;

FIG. **16** is a right side view thereof;

FIG. **17** is a left side view thereof;

FIG. **18** is a front view thereof;

FIG. **19** is a top view thereof; and

FIG. **20** is a bottom view thereof.

FIG. **21** is a left perspective view of a fourth embodiment of the foot for a side mirror for a vehicle according to our novel design;

FIG. **22** is a front view thereof;

FIG. **23** is a right side view thereof;

FIG. **24** is a left side view thereof;

FIG. **25** is a top view thereof; and,

FIG. **26** is a bottom view thereof.

The third embodiment is a mirror image of the side mirror for a vehicle as shown in FIGS. **1-6**. The fourth embodiment is a mirror image of the side mirror for a vehicle as shown in FIGS. **7-11**.

In the drawings, the broken lines show portions of a side mirror for a vehicle and form no part of the claimed design.

1 Claim, 14 Drawing Sheets

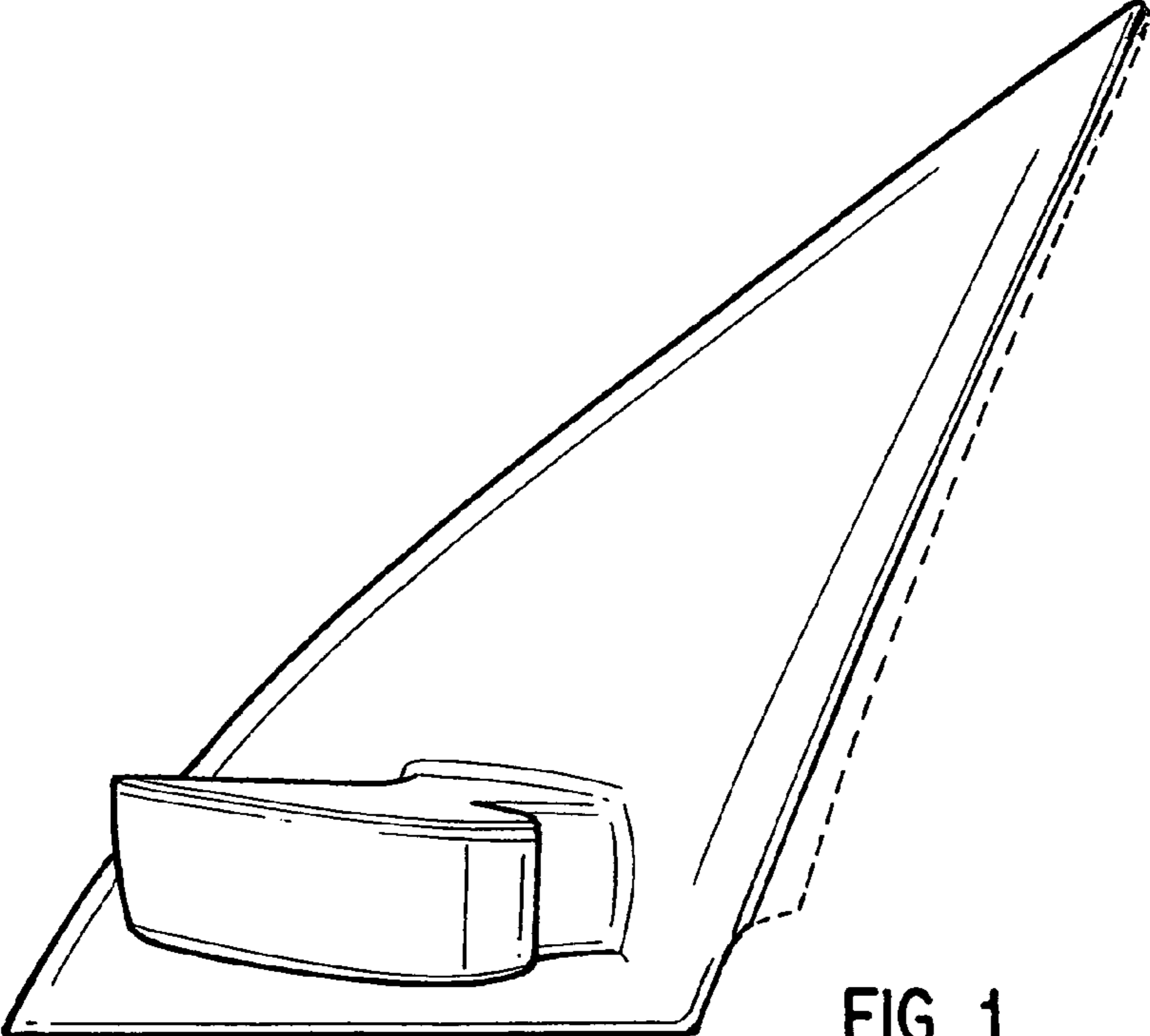

FIG. 1

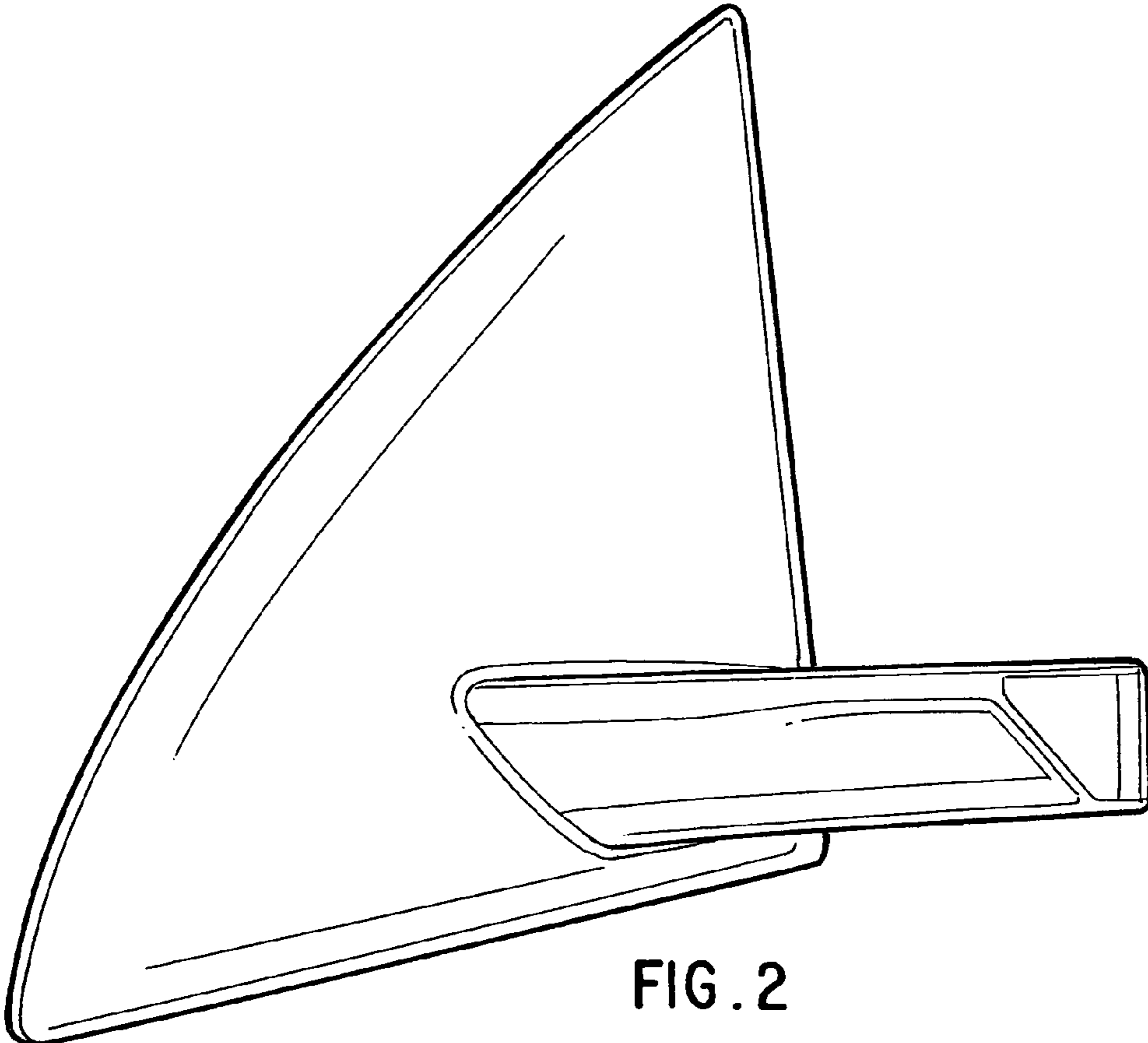

FIG. 2

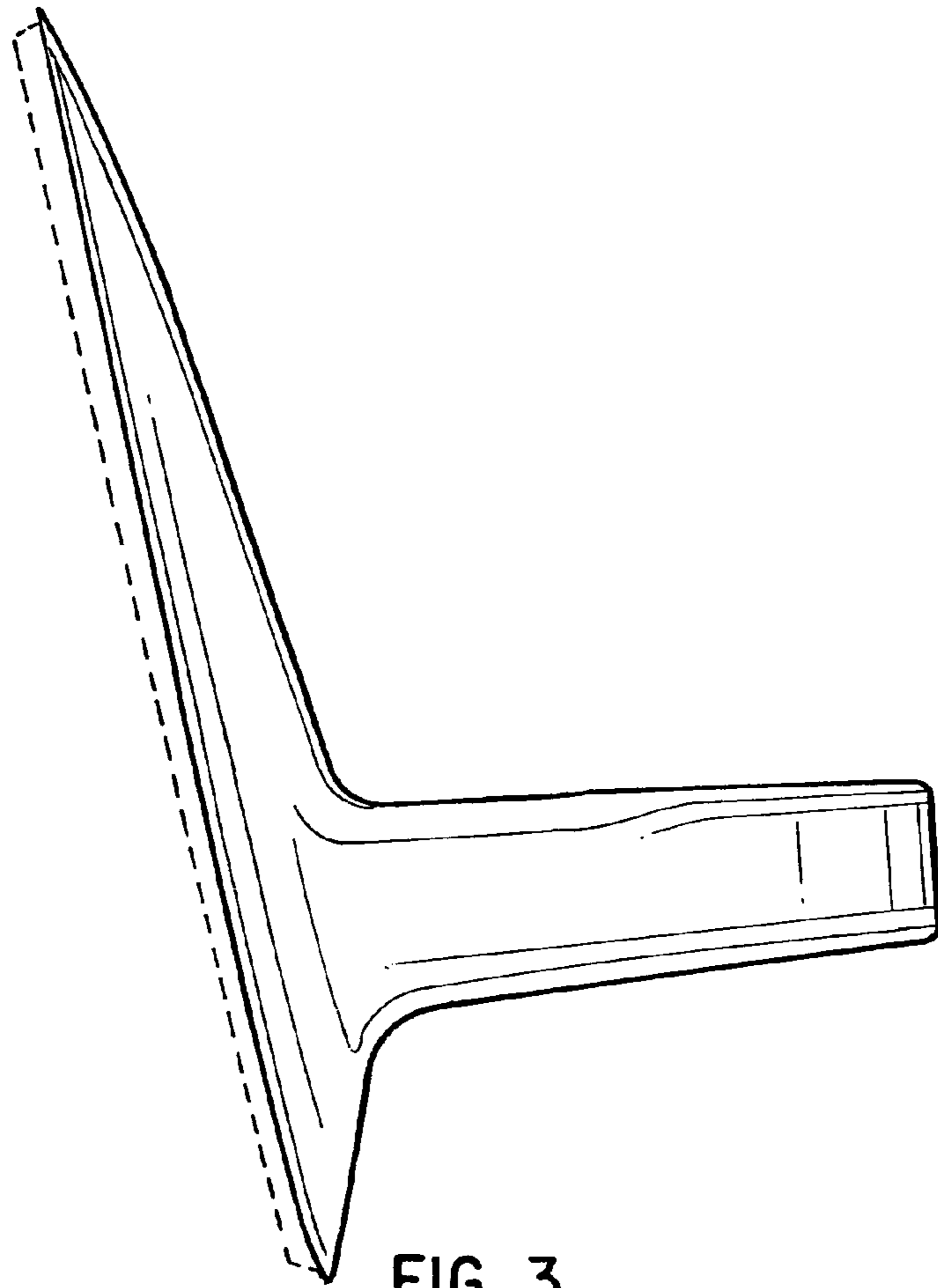

FIG. 3

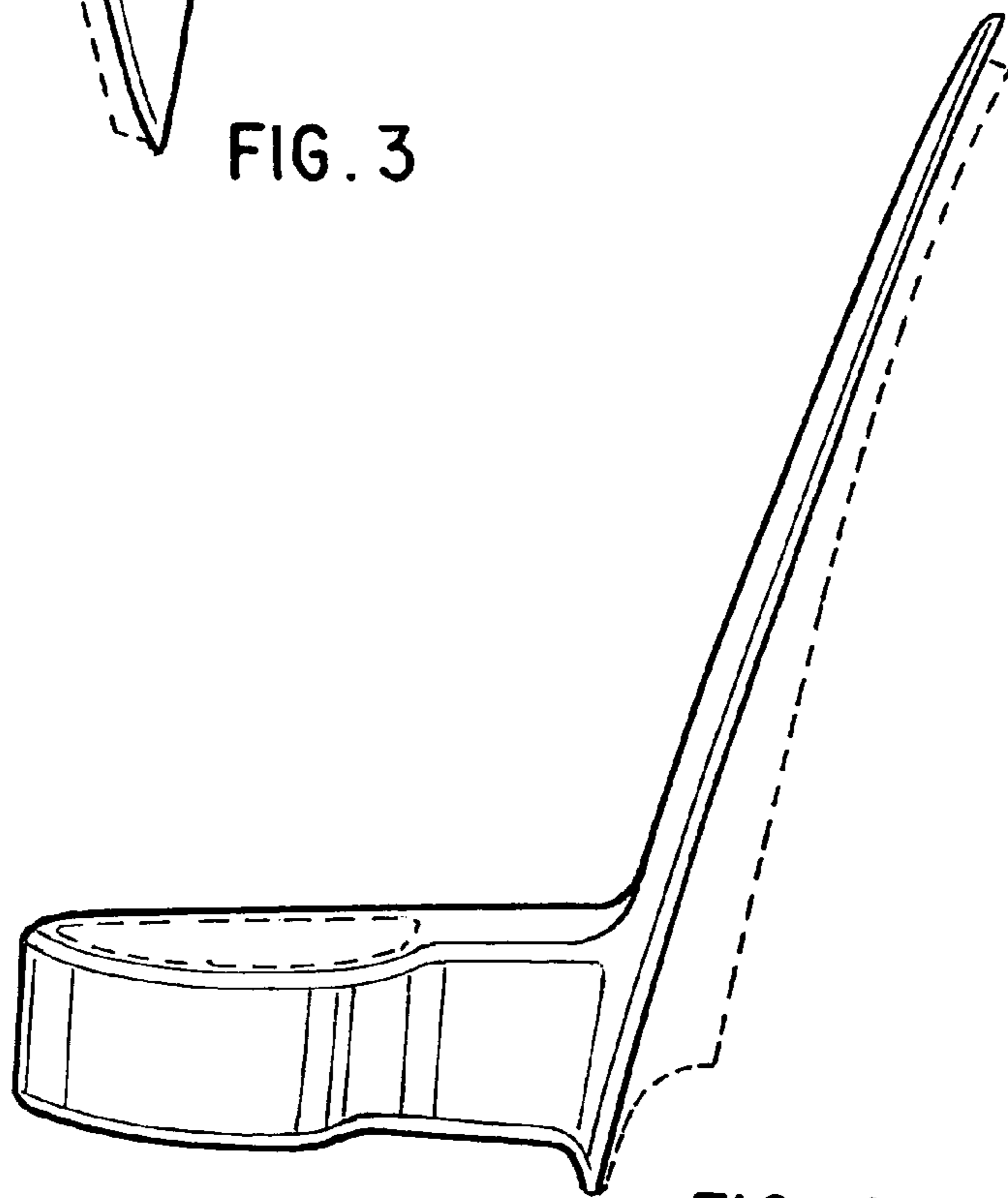

FIG. 4

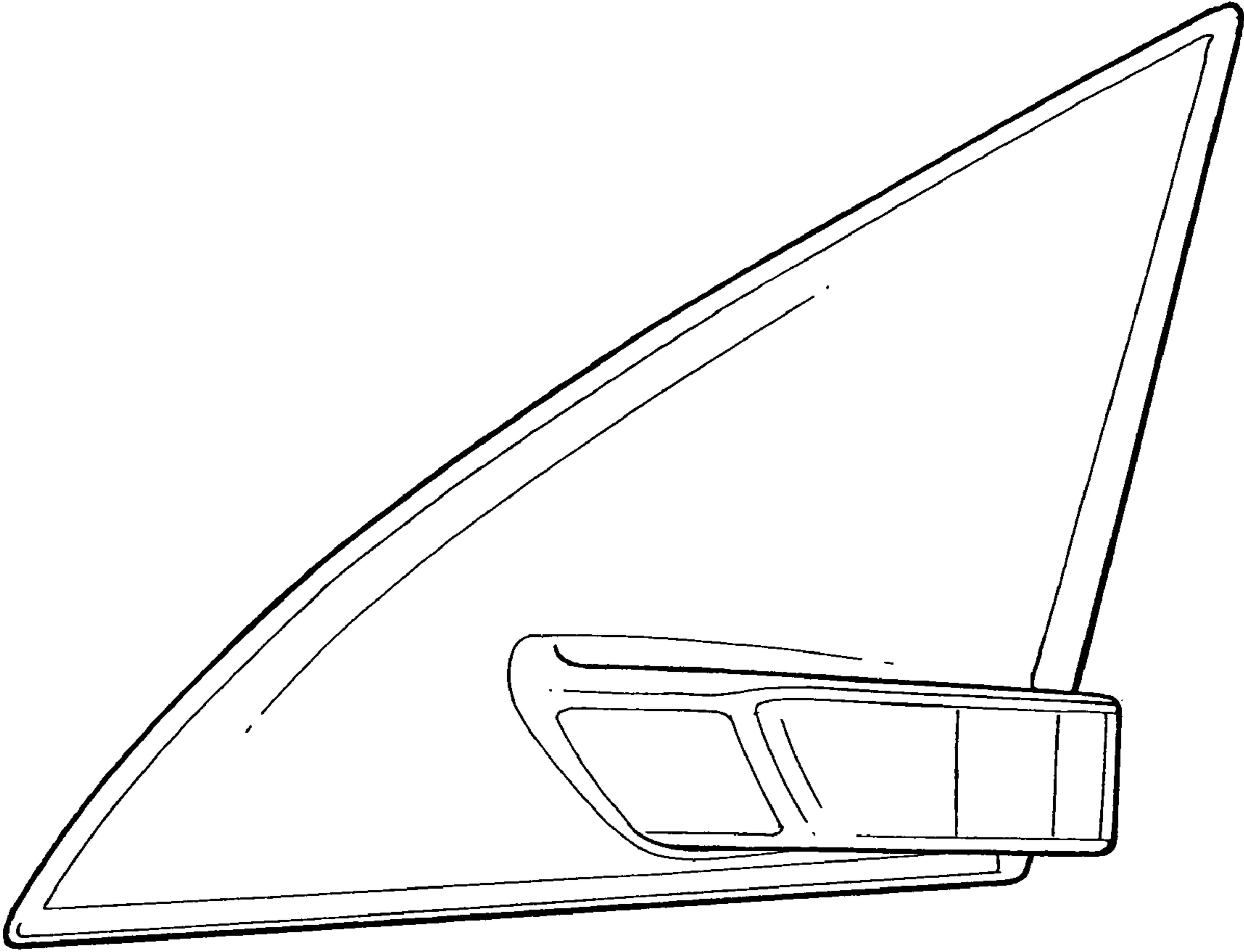

FIG. 5

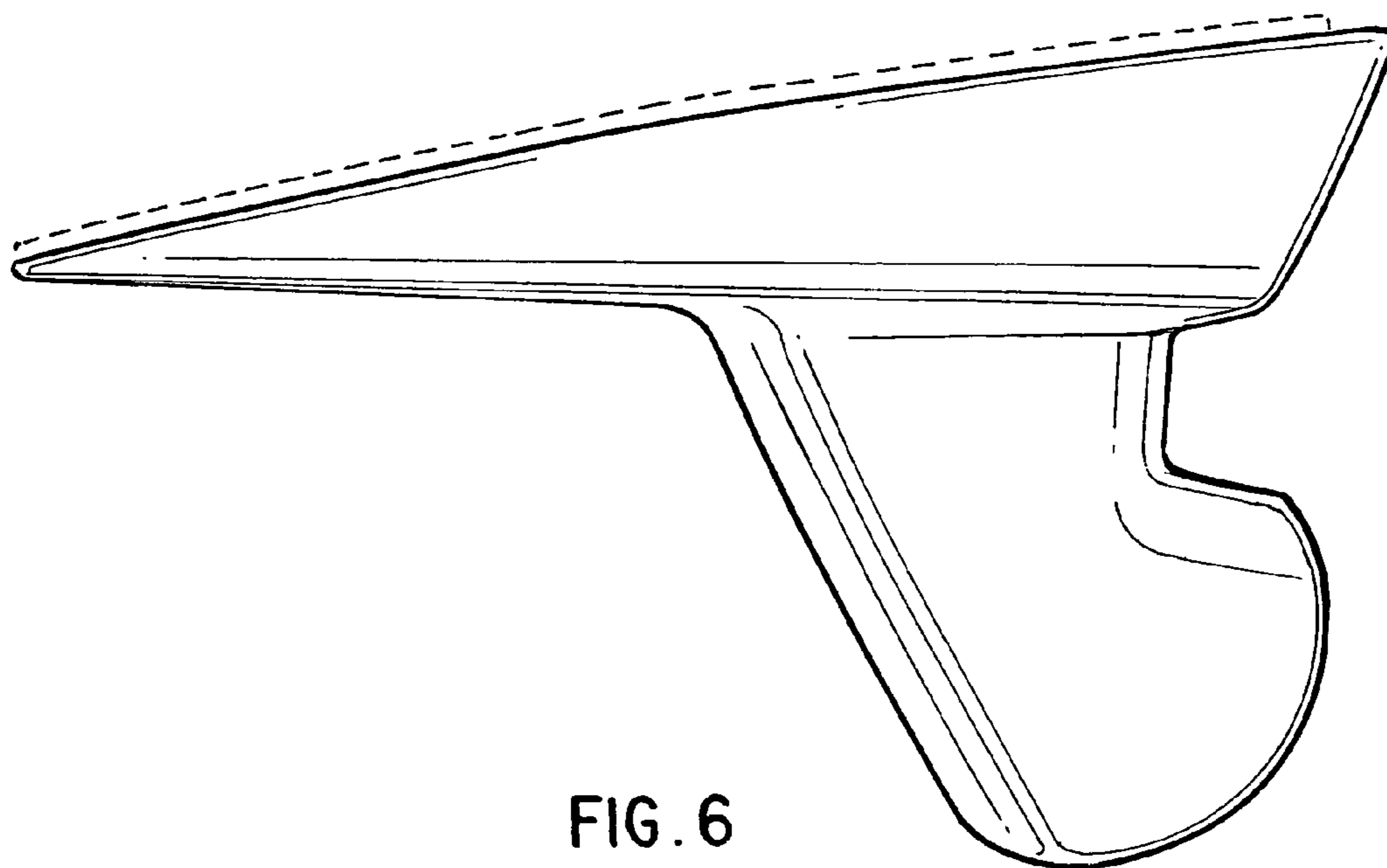

FIG. 6

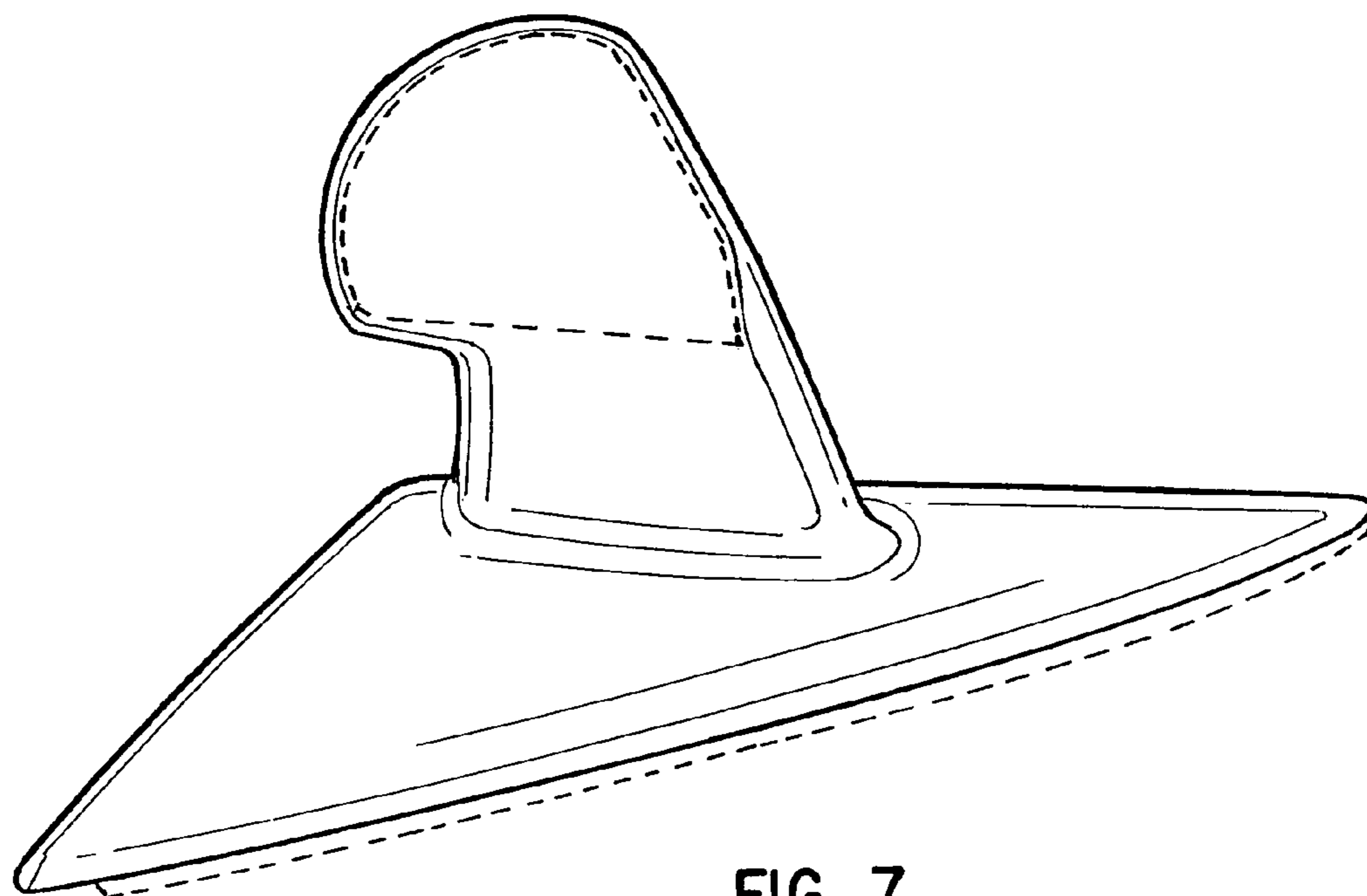

FIG. 7

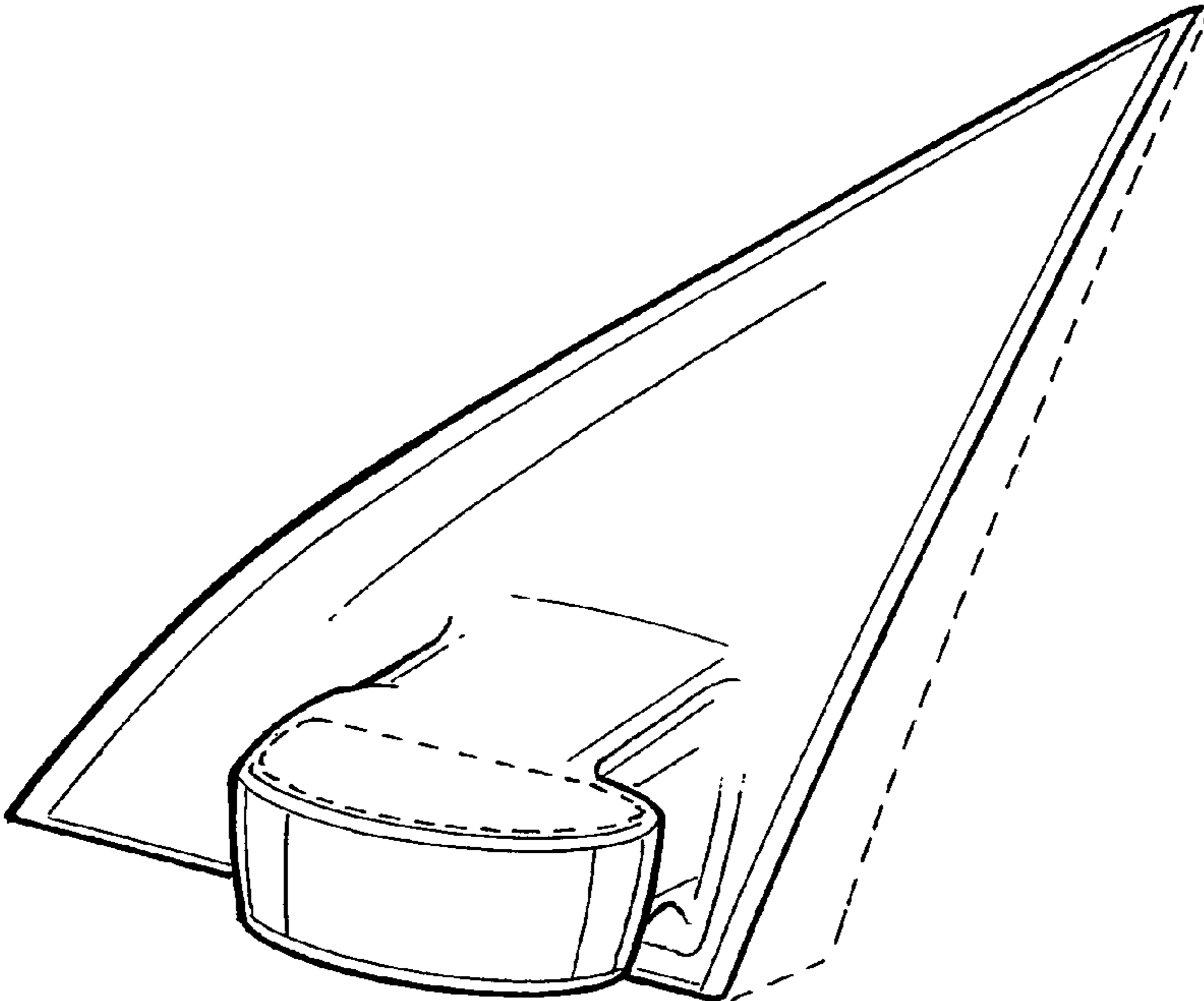

FIG. 8

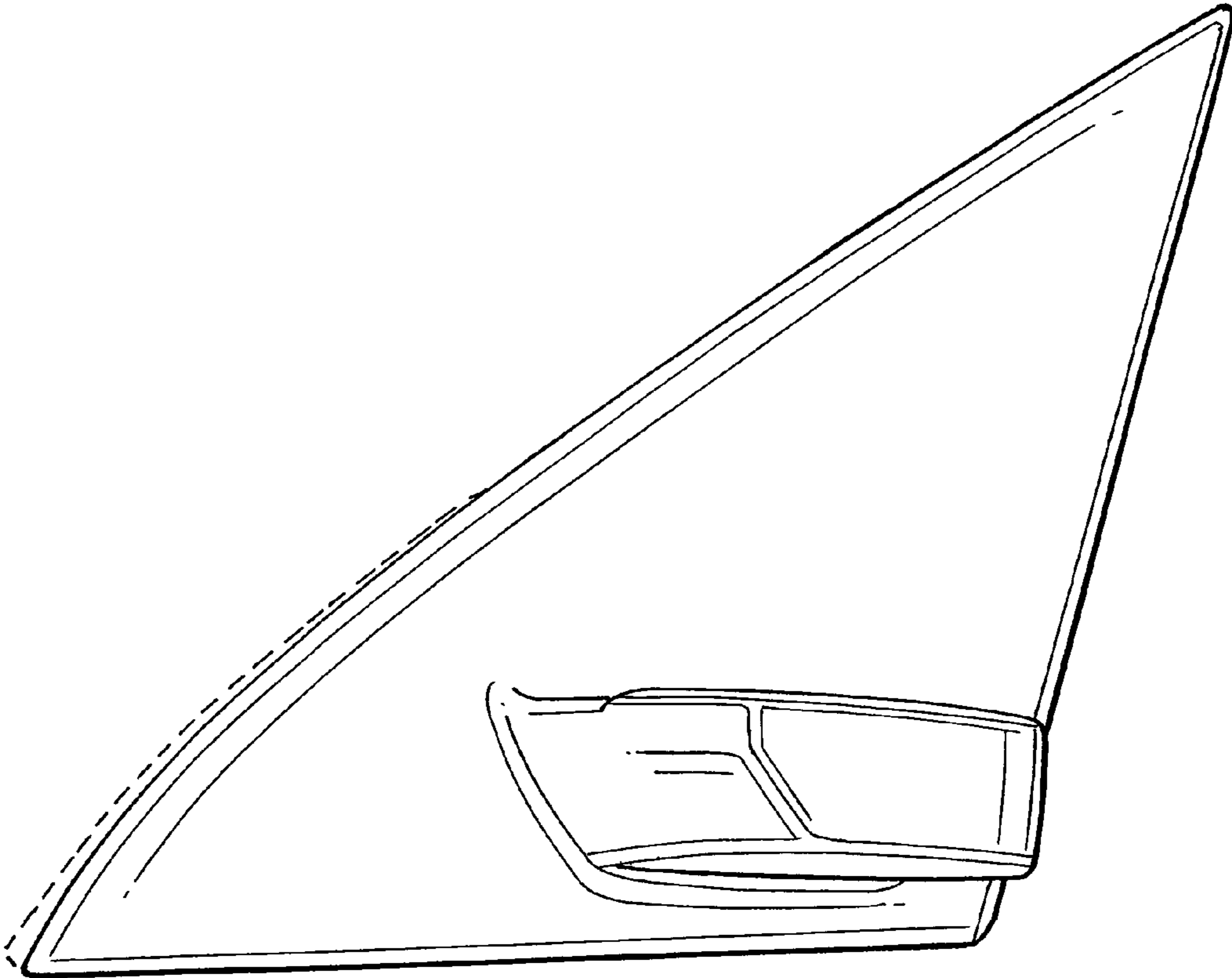

FIG. 9

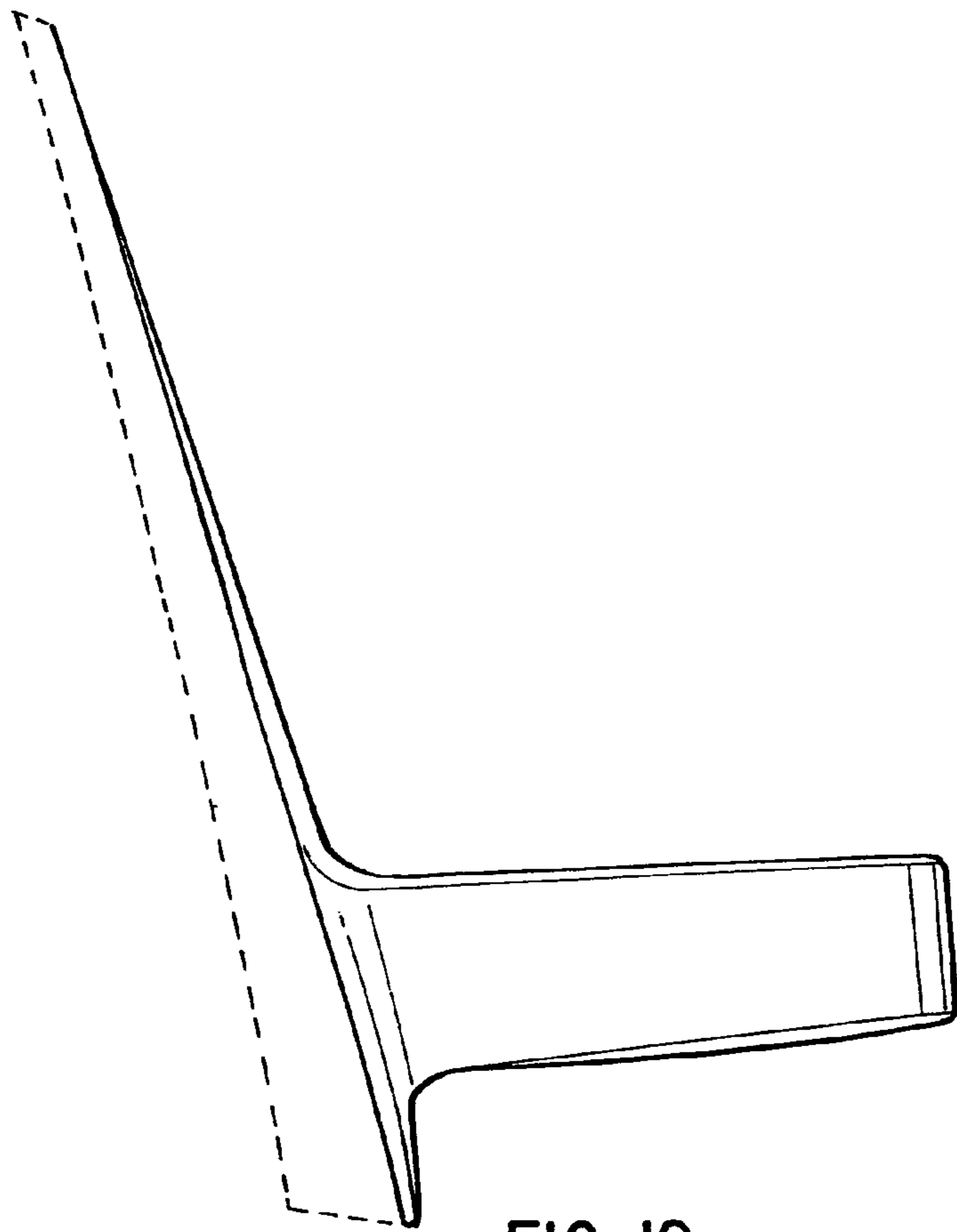

FIG. 10

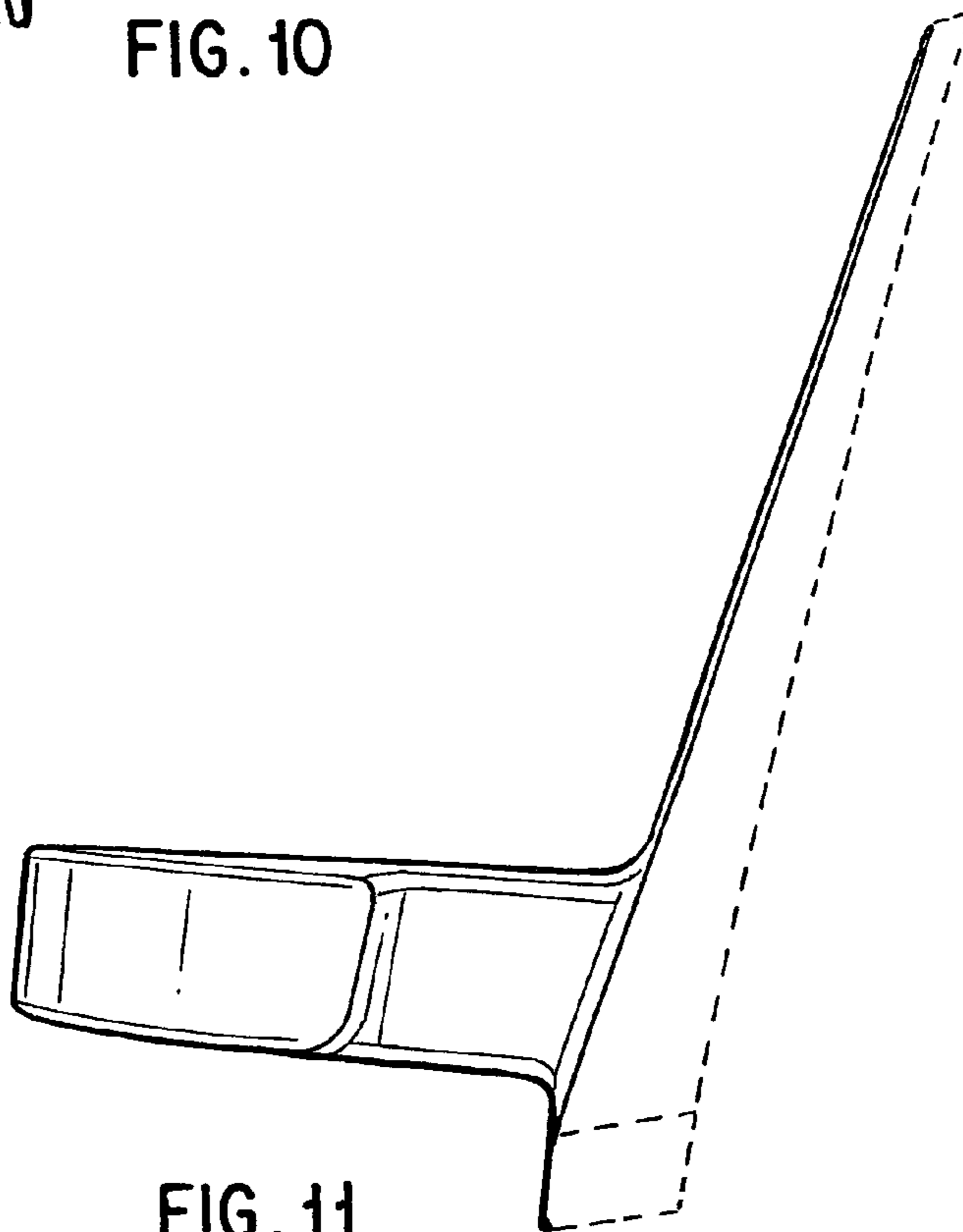

FIG. 11

FIG. 12

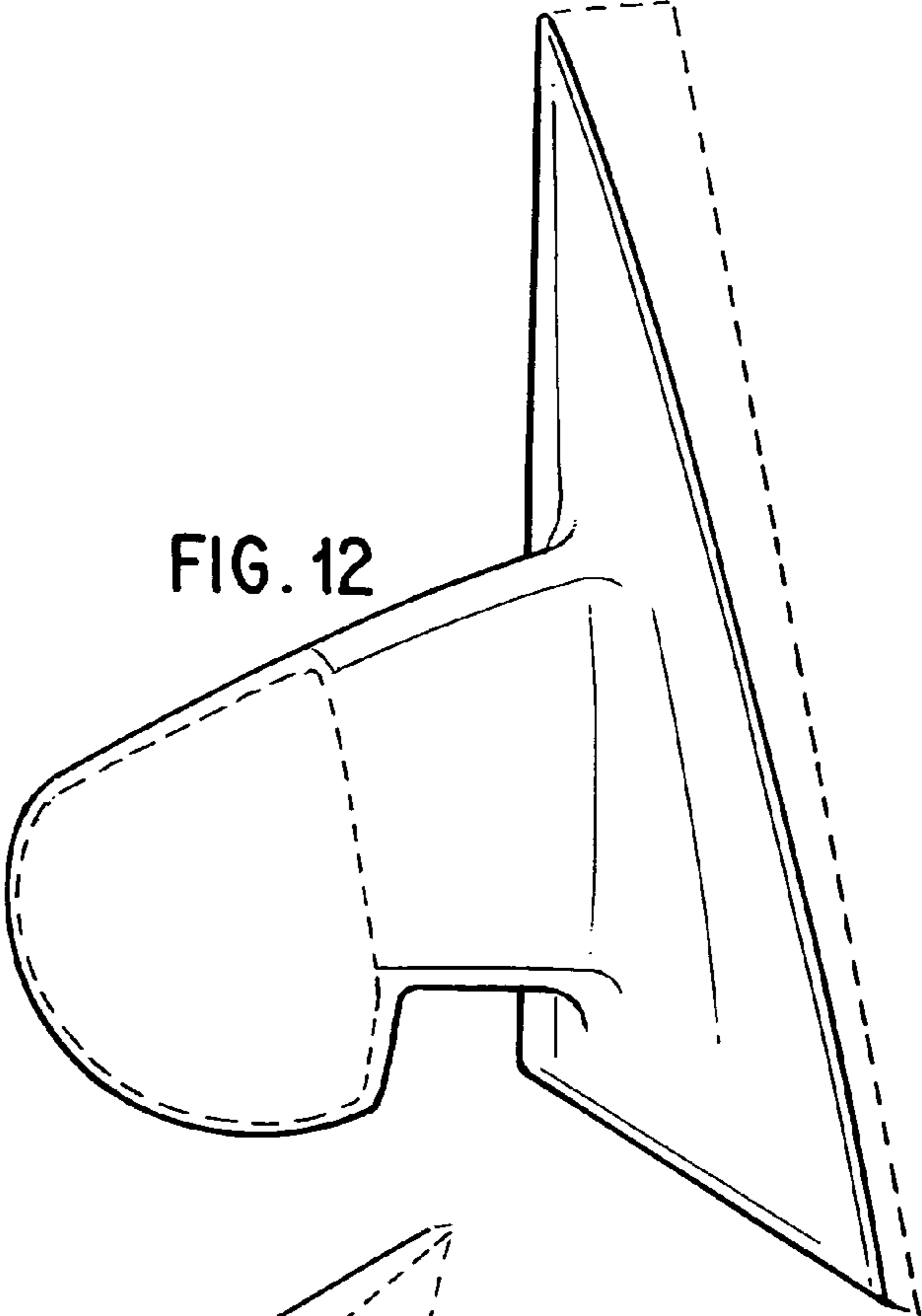
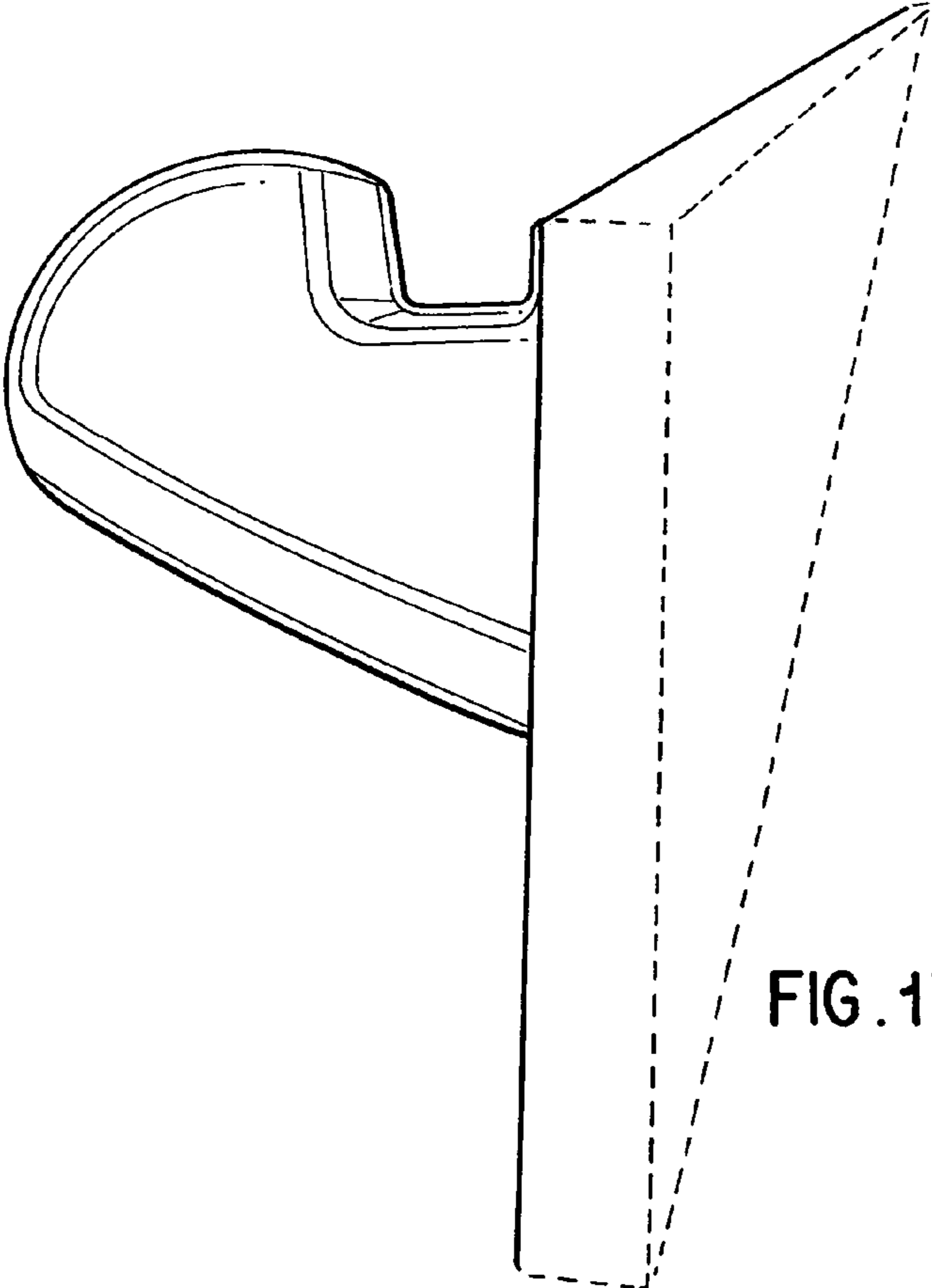

FIG. 13



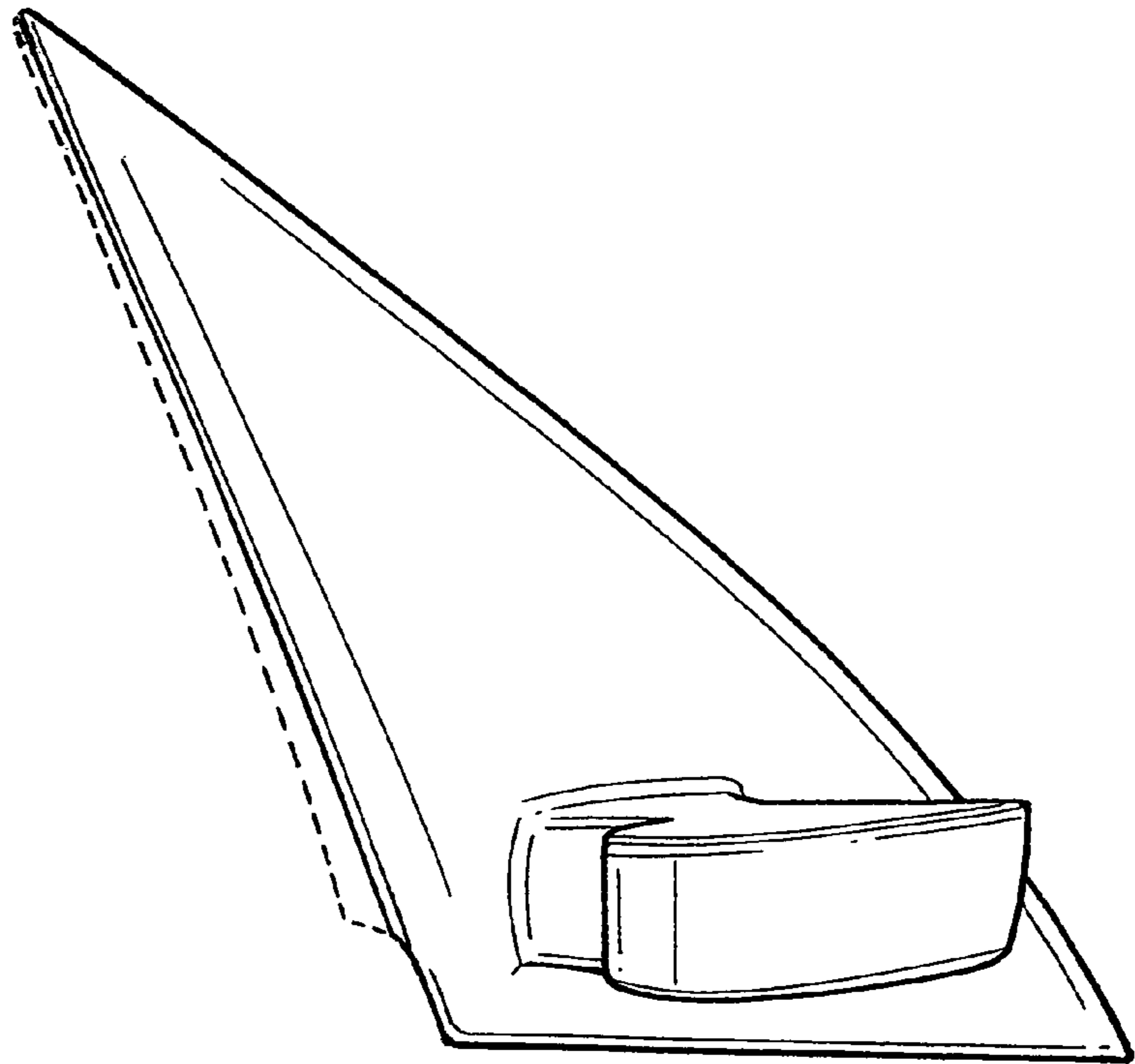

FIG. 14

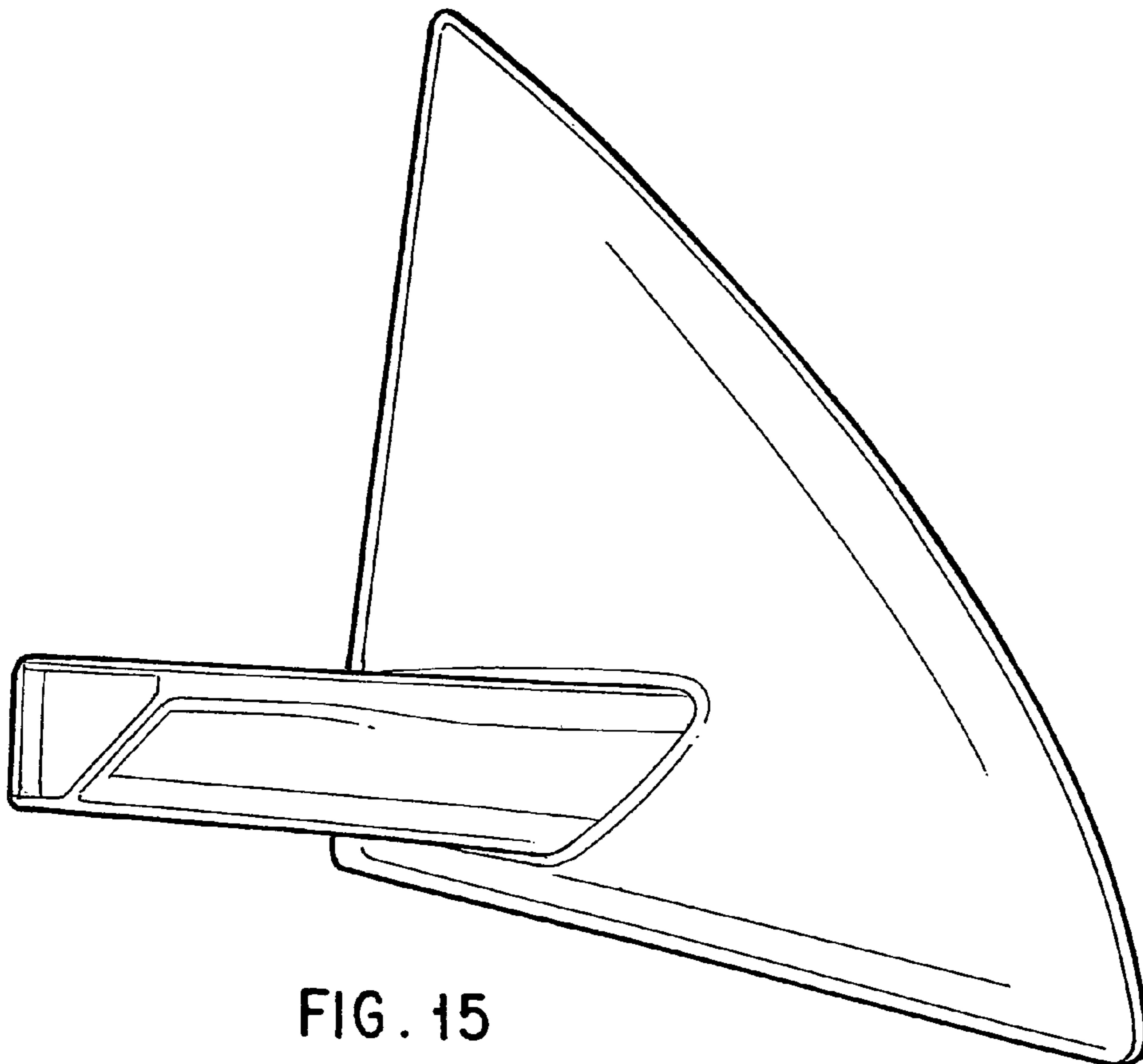

FIG. 15

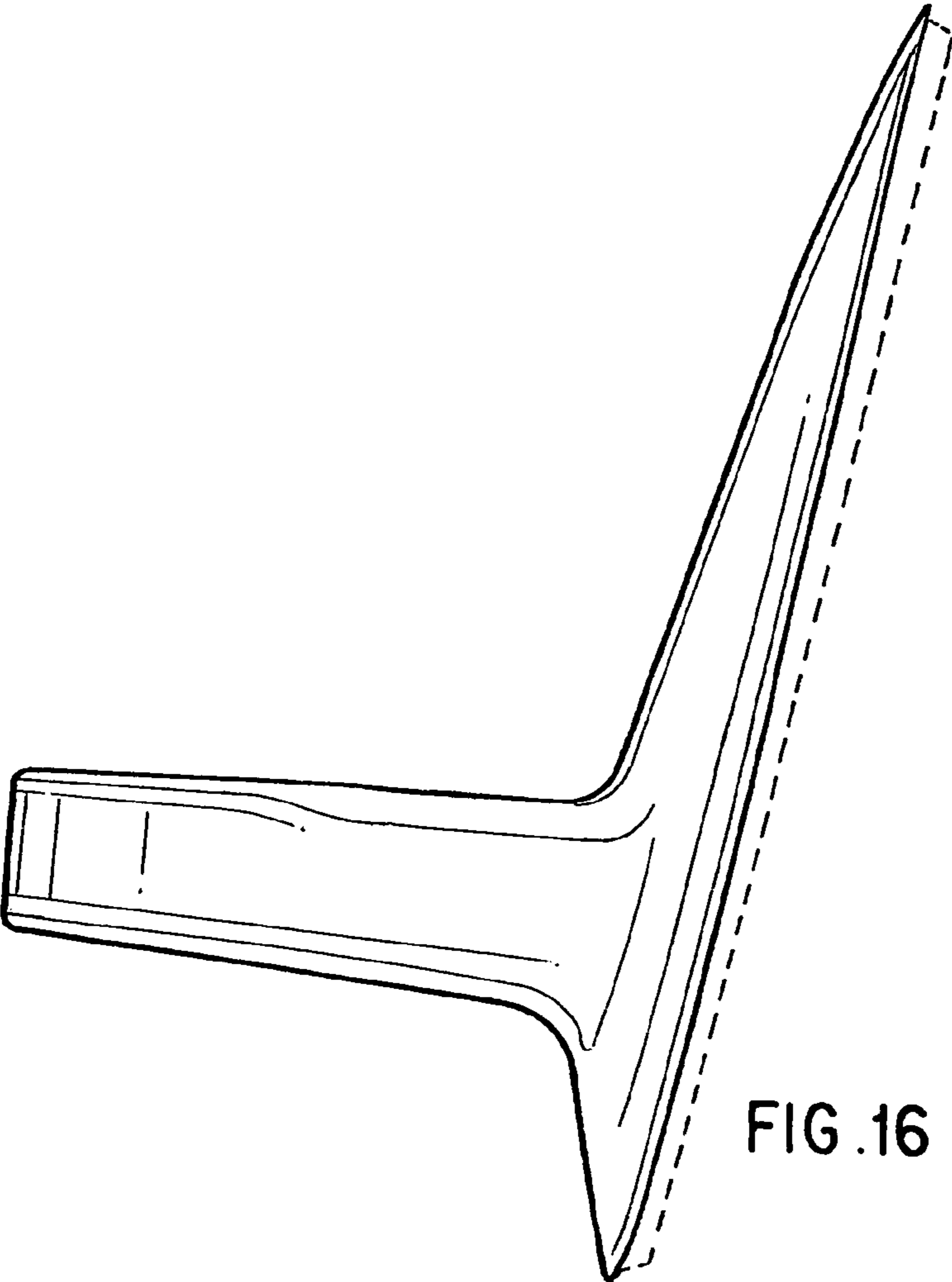

FIG. 16

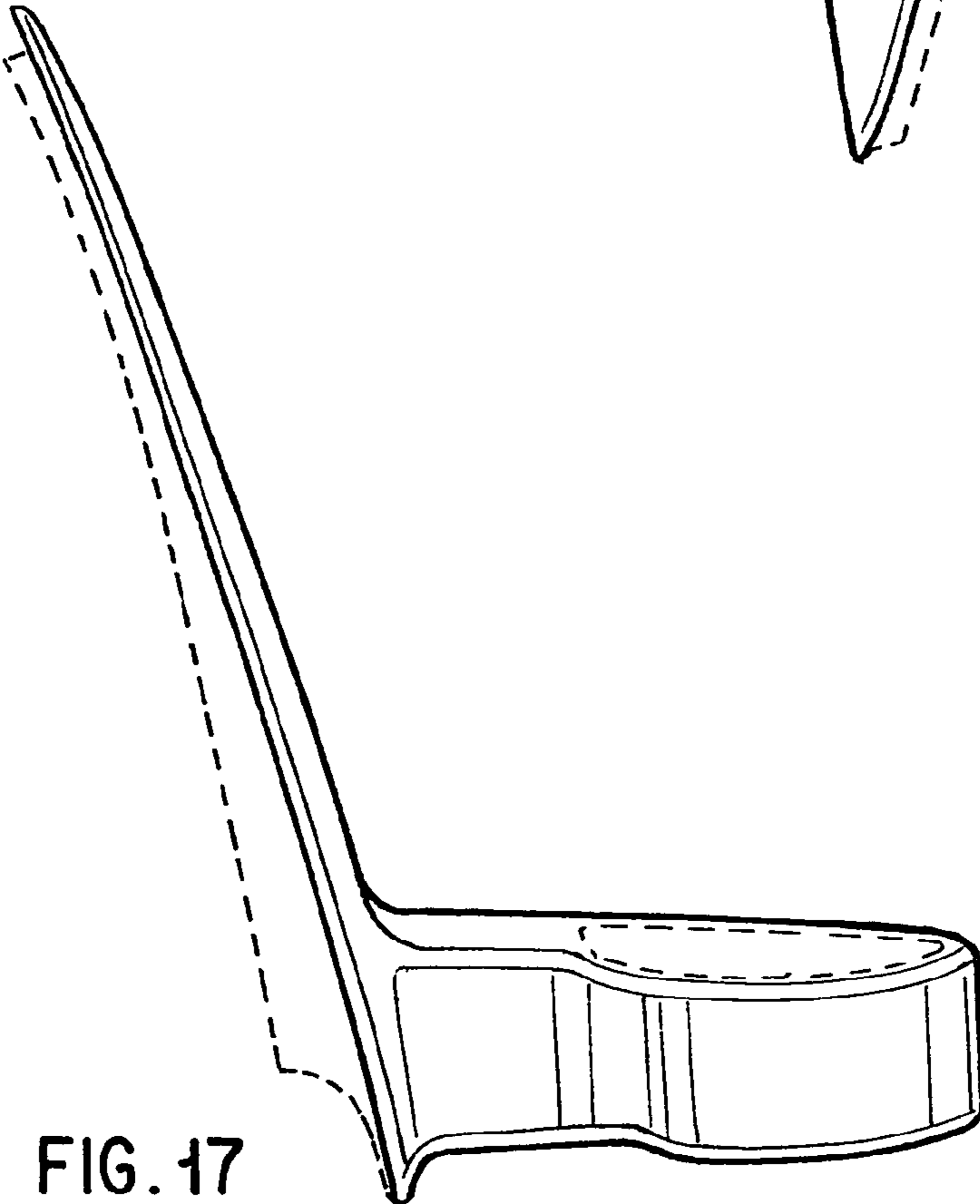

FIG. 17

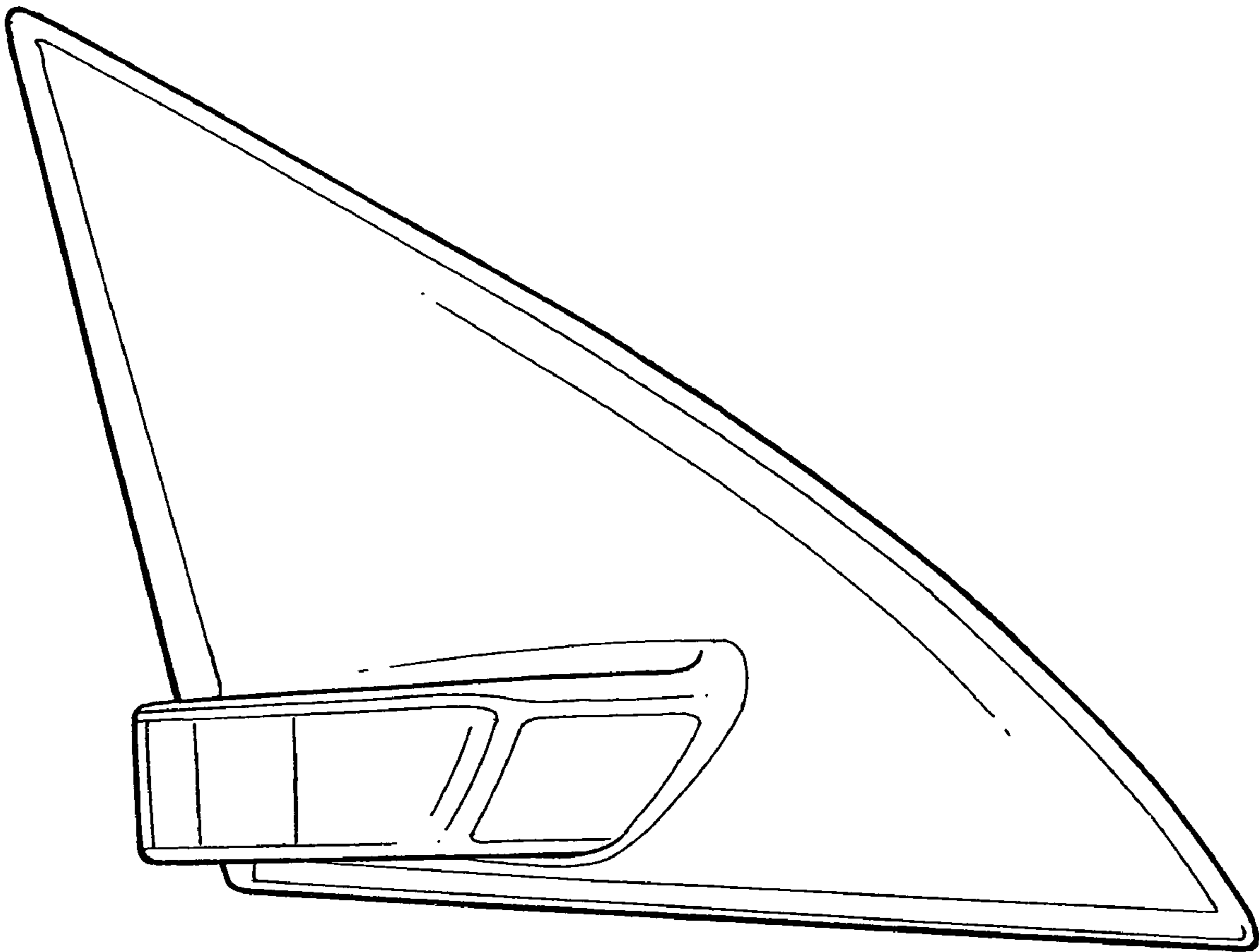

FIG. 18

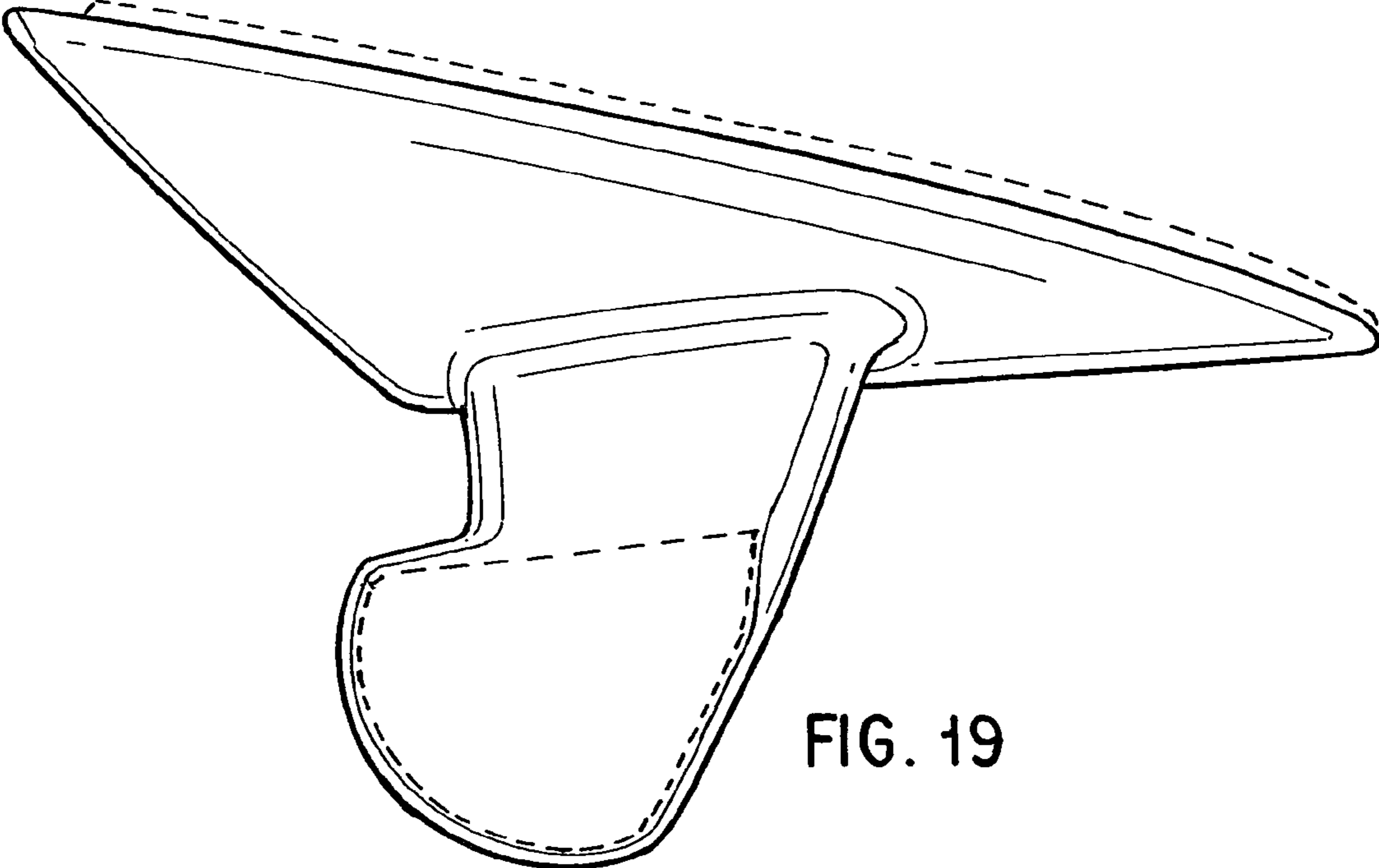

FIG. 19

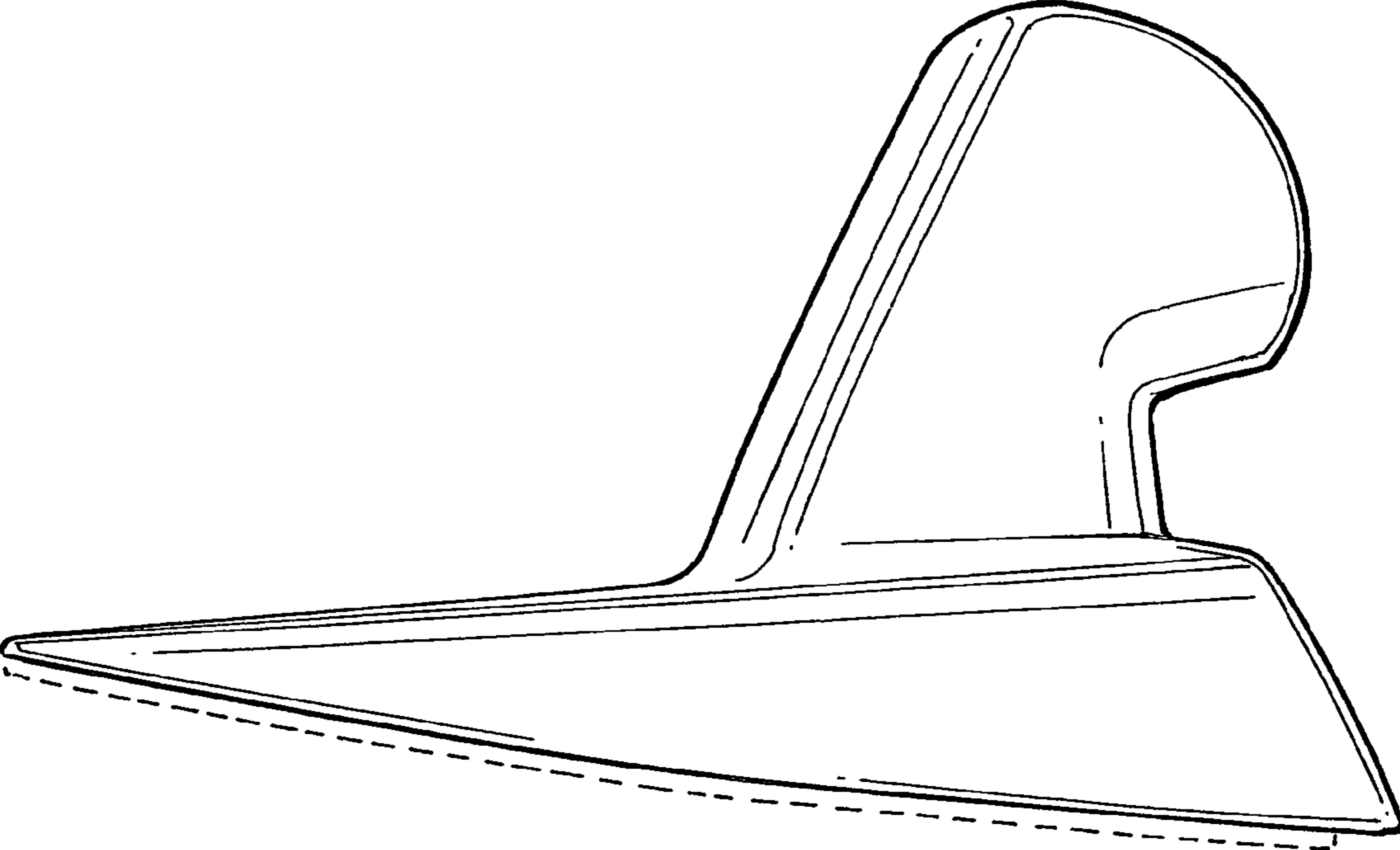

FIG. 20

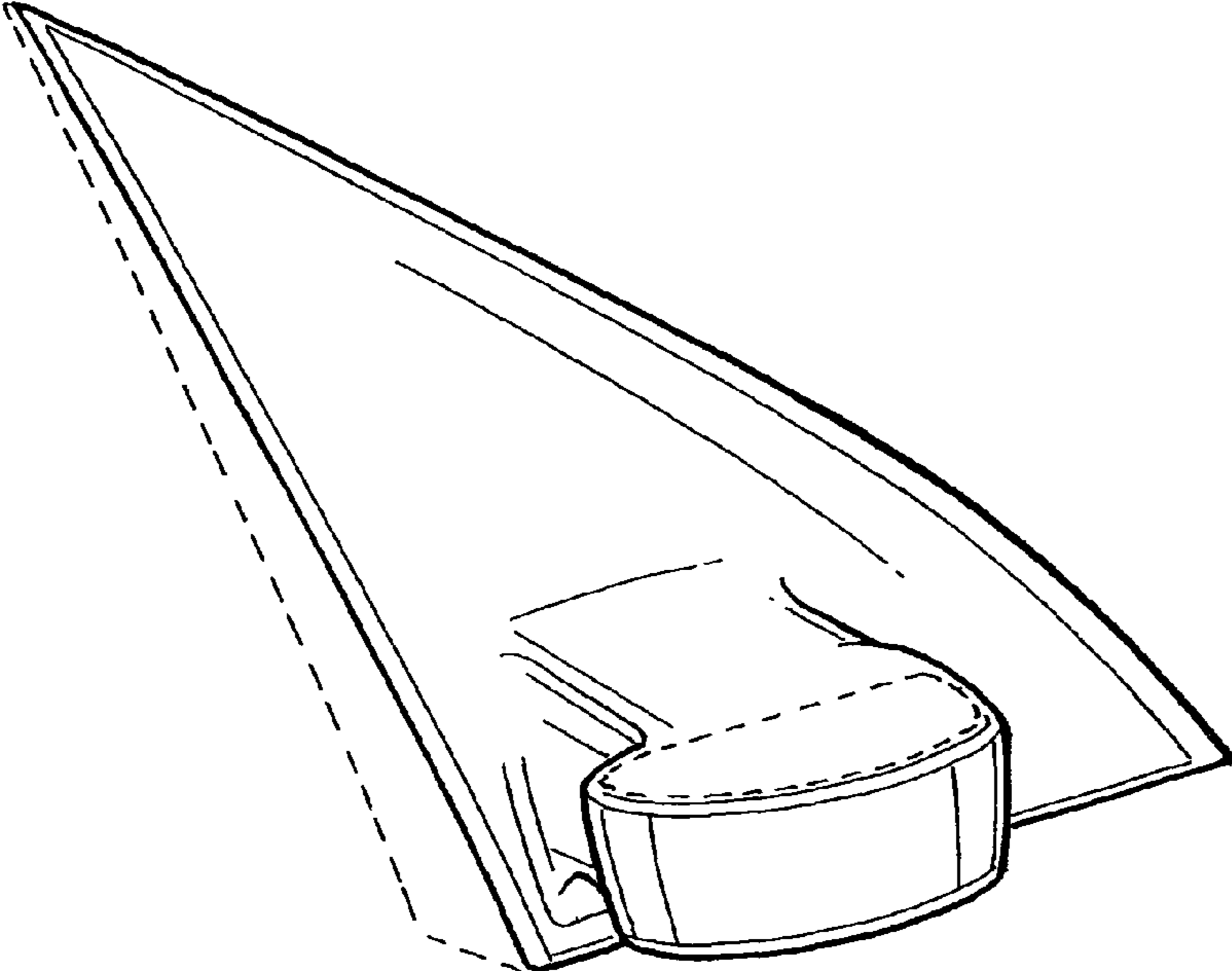

FIG. 21

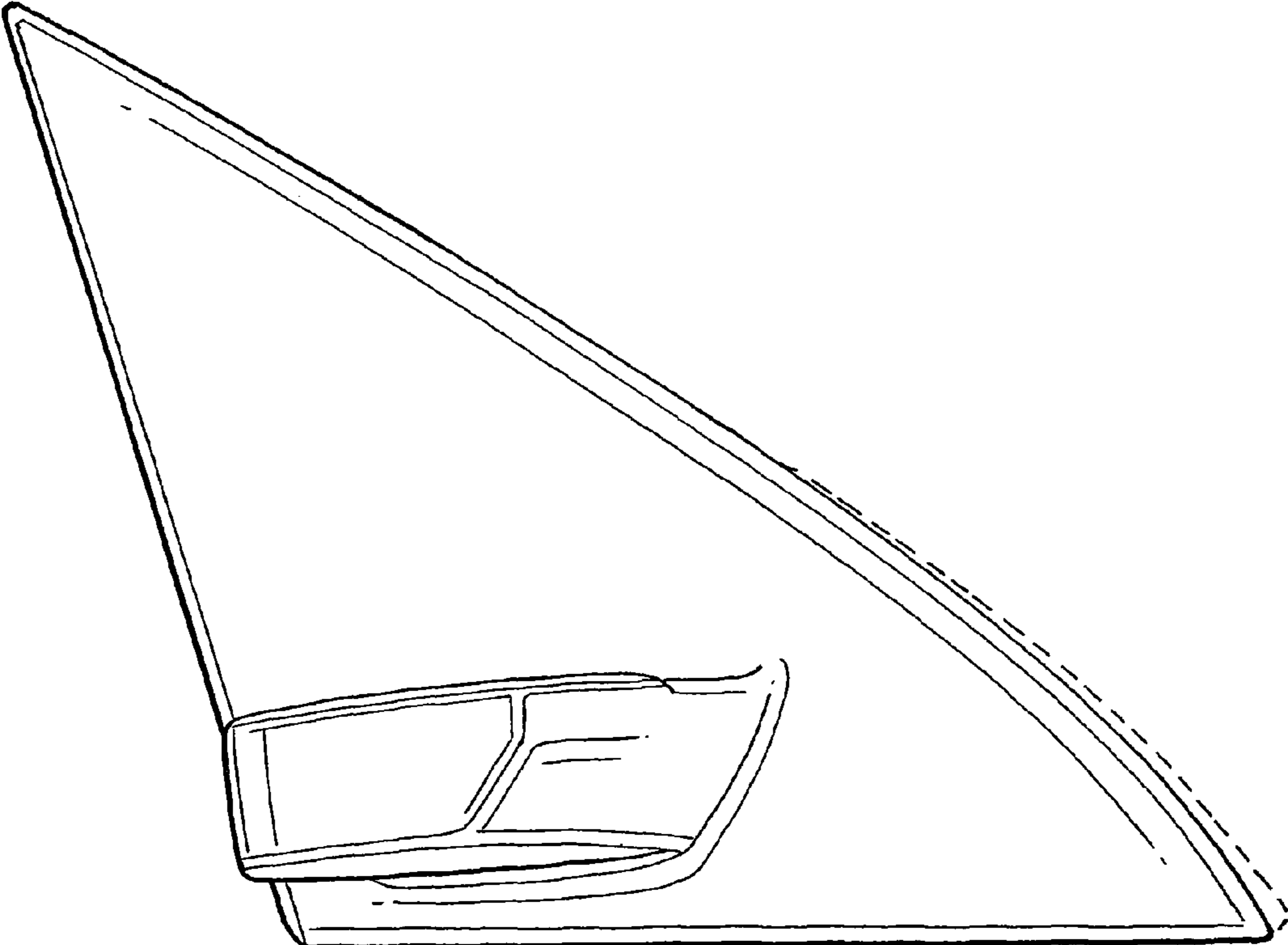

FIG. 22

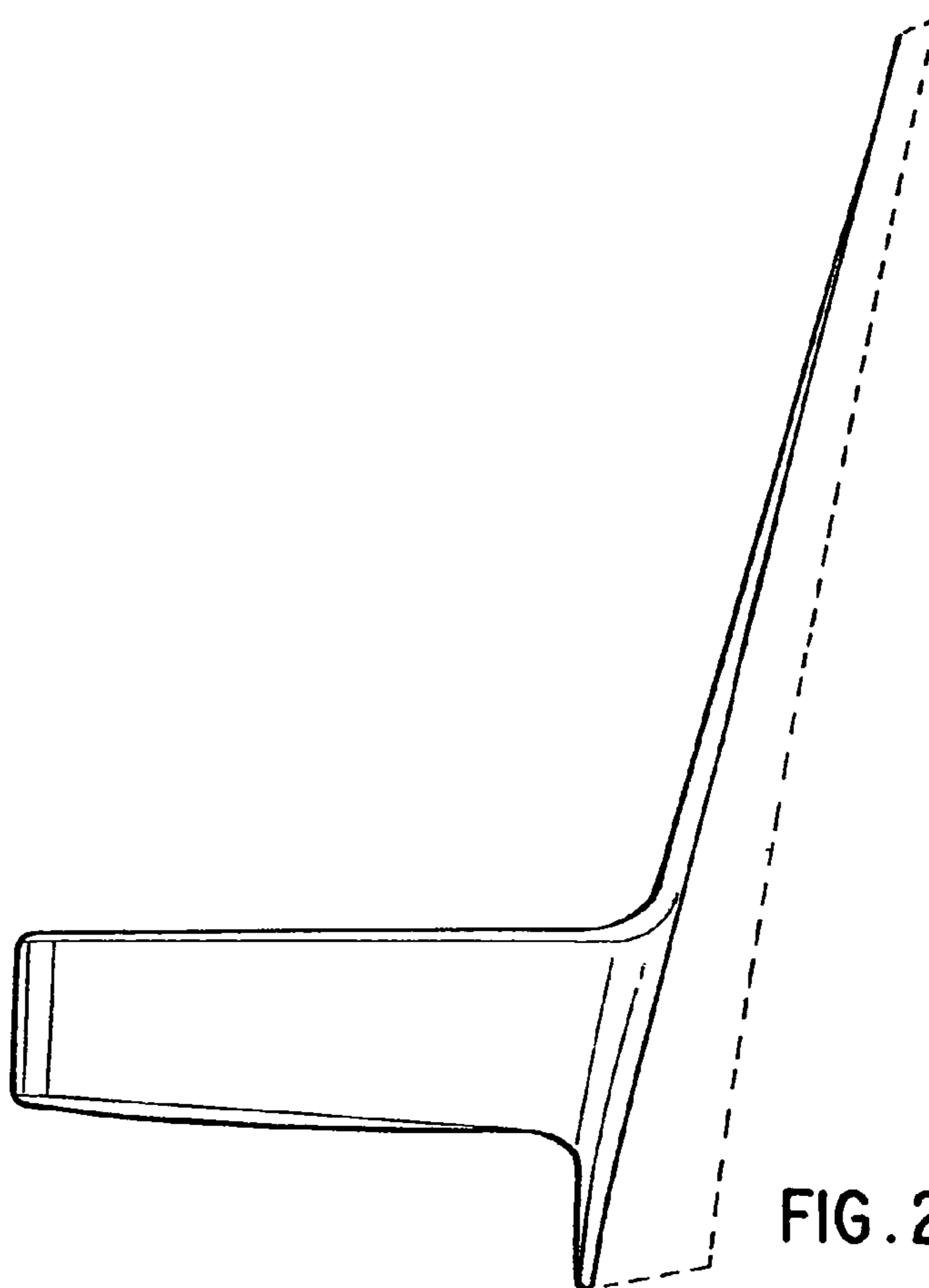

FIG. 23

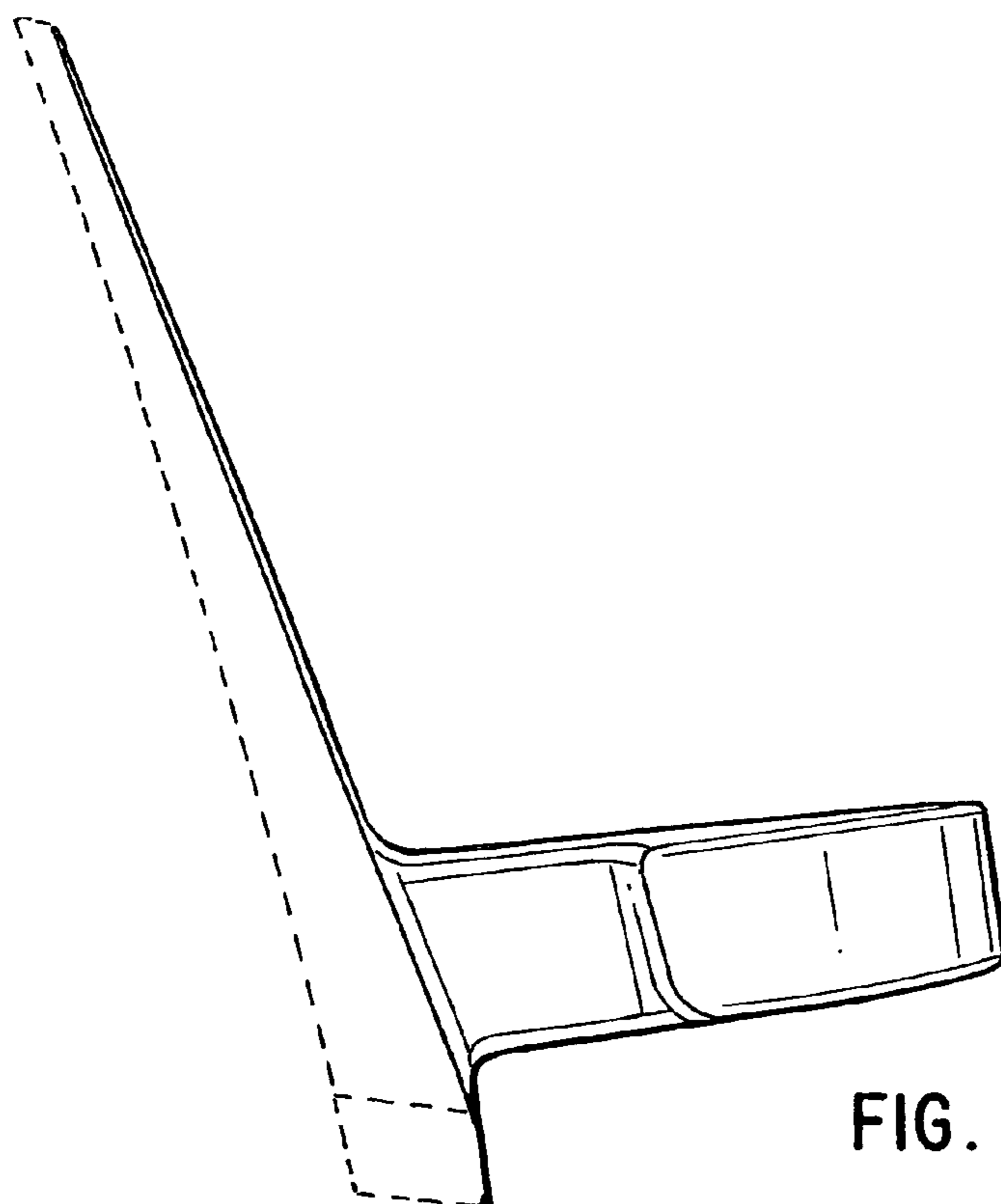

FIG. 24

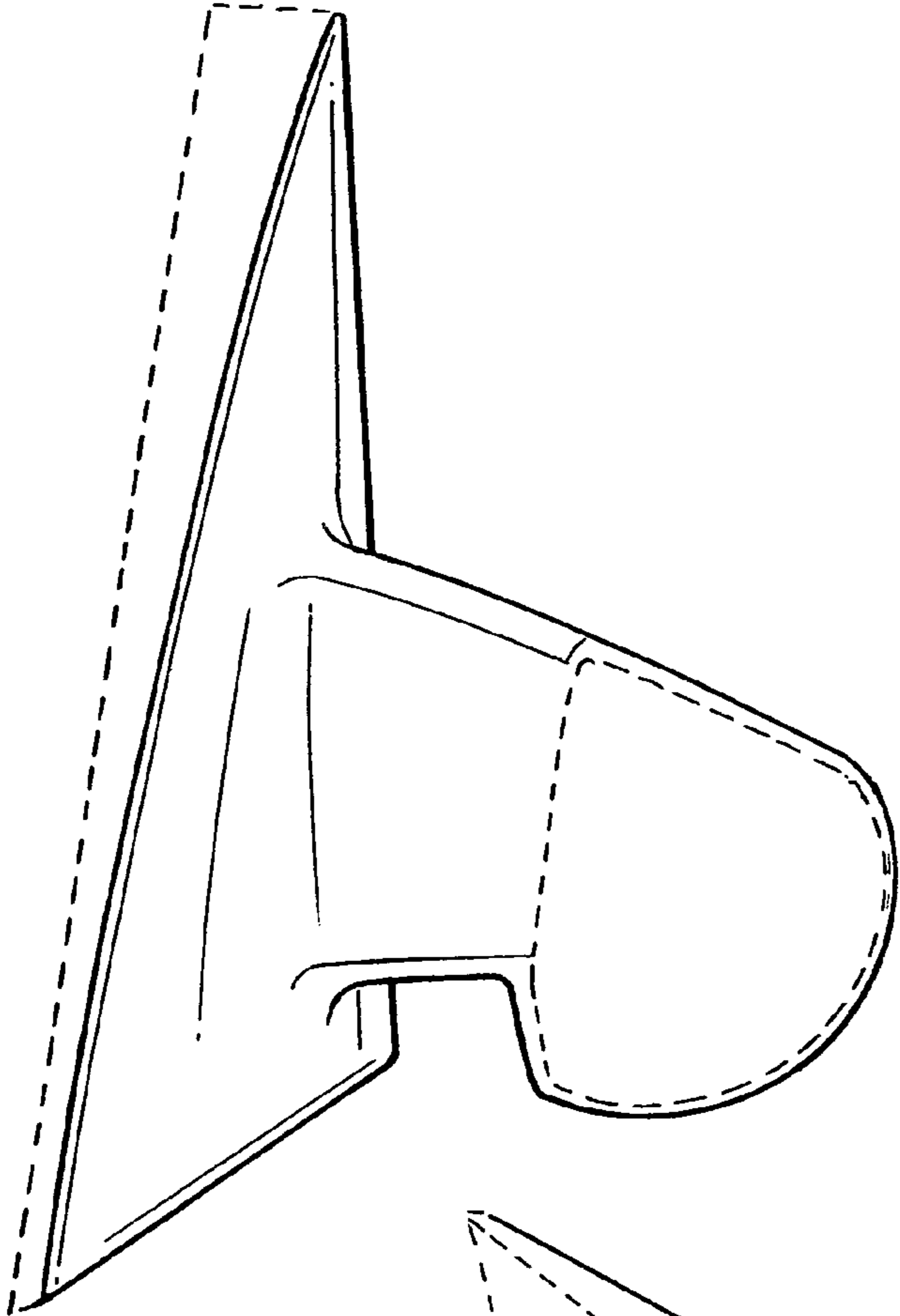

FIG. 25

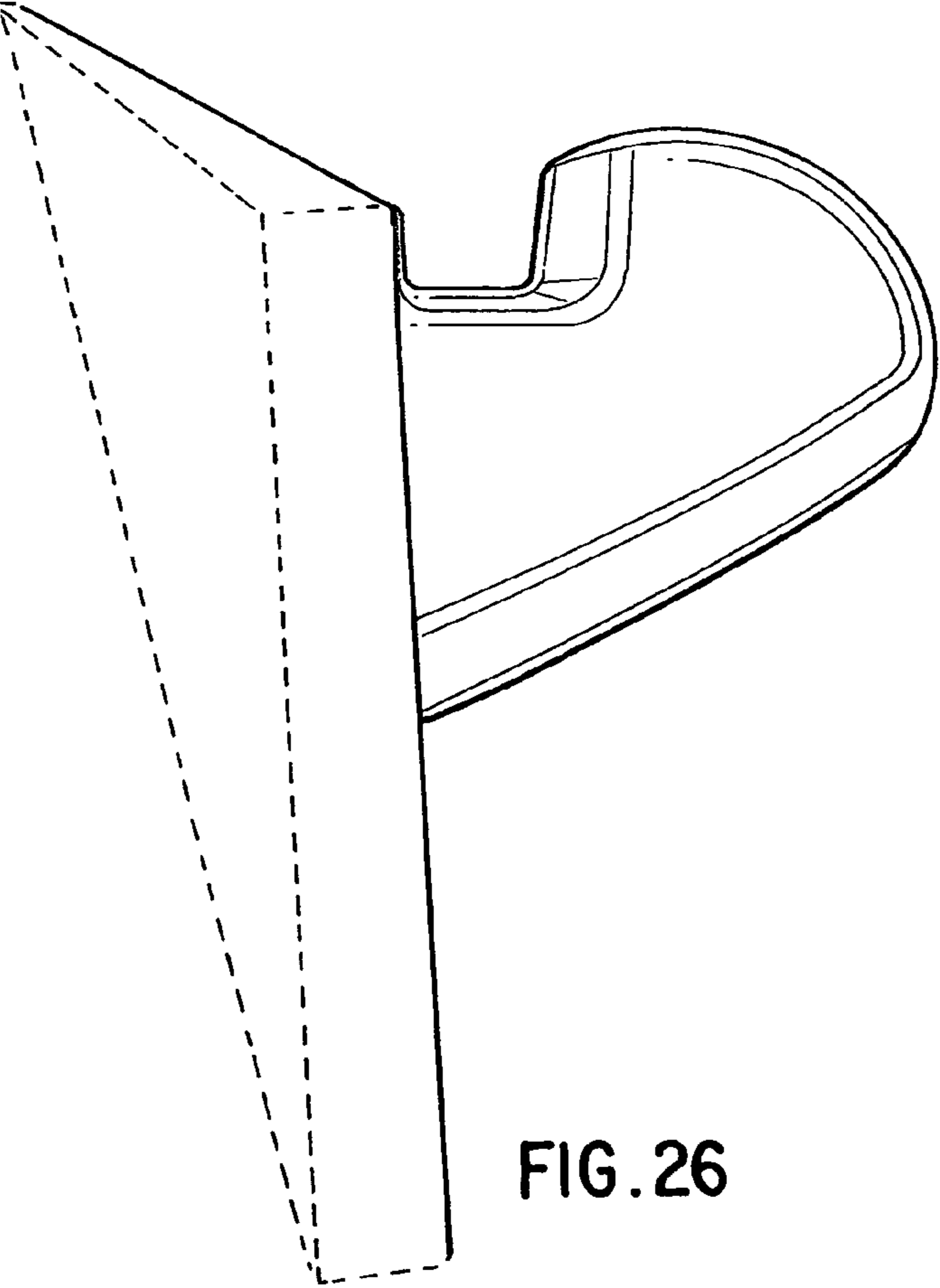

FIG. 26