



US00D617493S

(12) **United States Design Patent**  
**Engle et al.**

(10) **Patent No.:** **US D617,493 S**  
(45) **Date of Patent:** **\*\* Jun. 8, 2010**

(54) **FLOW-THROUGH LED CARRIER FOR LUMINAIRE**

(75) Inventors: **Joseph D. Engle**, Taylors, SC (US);  
**Jason E. Duckworth**, Simpsonville, SC (US);  
**Ezekial T. Hill, III**, Spartanburg, SC (US);  
**Jamey L. Butteris**, Simpsonville, SC (US)

(73) Assignee: **Hubbell Incorporated**, Orange, CT (US)

(\*\*) Term: **14 Years**

(21) Appl. No.: **29/347,155**

(22) Filed: **Oct. 6, 2009**

(51) **LOC (9) Cl.** ..... **26-99**

(52) **U.S. Cl.** ..... **D26/118**

(58) **Field of Classification Search** ..... D26/2,  
D26/142, 134, 129, 124, 118, 128, 113, 121,  
D26/125, 131, 130, 60, 61, 138, 93, 102,  
D26/103, 106, 107, 110, 147, 153, 149, 141,  
D26/145, 155, 24, 63, 120, 122, 123, 65,  
D26/88; D8/396; 362/294, 98, 641, 257,  
362/269, 270, 277, 279, 285, 341, 347, 350,  
362/351, 363, 395, 410

See application file for complete search history.

(56) **References Cited**

**U.S. PATENT DOCUMENTS**

4,587,601 A	5/1986	Collins
5,890,794 A	4/1999	Abtahi et al.
6,573,536 B1	6/2003	Dry
6,762,562 B2	7/2004	Leong
6,815,724 B2	11/2004	Dry
6,831,303 B2	12/2004	Dry
6,848,819 B1	2/2005	Arndt et al.

7,014,337 B2 *	3/2006	Chen	.....	362/240
7,097,337 B2	8/2006	Kim et al.		
7,210,832 B2	5/2007	Huang		
7,242,028 B2	7/2007	Dry		
7,288,796 B2	10/2007	Dry		
7,360,925 B2	4/2008	Coushaine		

(Continued)

*Primary Examiner*—Cathron C Brooks

*Assistant Examiner*—Kevin K Rudzinski

(74) *Attorney, Agent, or Firm*—Mark S. Bicks; Alfred N. Goodman; Alan I. Cantor

(57) **CLAIM**

The ornamental design for a flow-through LED carrier for luminaire, as shown and described.

**DESCRIPTION**

FIG. 1 is a perspective view of a luminaire incorporating a flow-through LED carrier in accordance with the invention;

FIG. 2 is a perspective view of a flow-through LED carrier for luminaire in accordance with the invention;

FIG. 3 is a front elevational view of the carrier of FIG. 2;

FIG. 4 is a rear elevational view of the carrier of FIG. 2;

FIG. 5 is a left side elevational view of the carrier of FIG. 2;

FIG. 6 is a right side elevational view of the carrier of FIG. 2;

FIG. 7 is a top plan view of the carrier of FIG. 2; and,

FIG. 8 is a bottom plan view of the carrier of FIG. 2.

The surface character of the interior portions of the carrier, seen in FIGS. 2, 7 and 8, is consistent throughout the full length of thereof. The broken lines are directed to environment, are for illustrative purposes only, and form no part of the claimed design or any embodiment thereof.

**1 Claim, 5 Drawing Sheets**

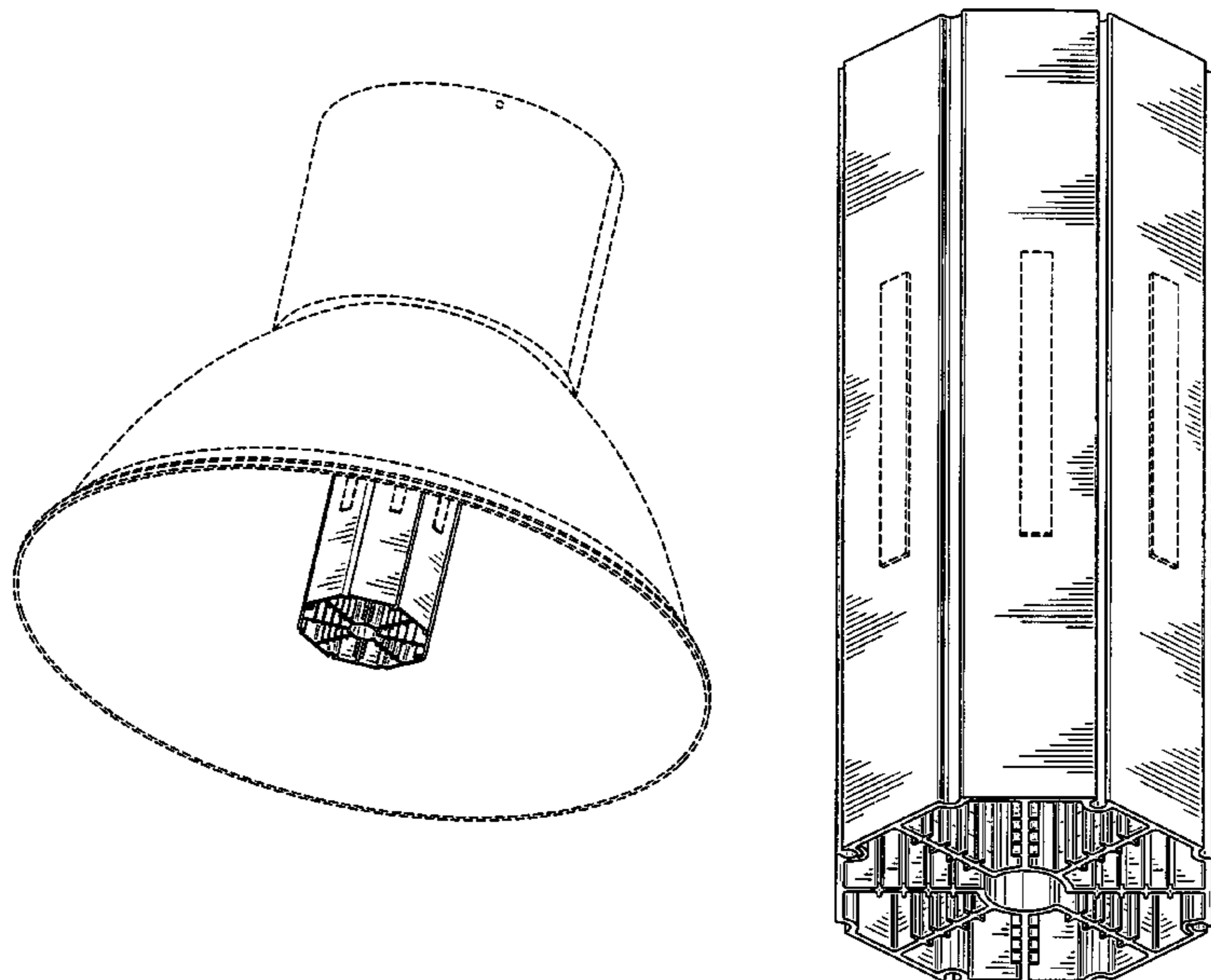

# US D617,493 S

Page 2

## U.S. PATENT DOCUMENTS

7,413,326	B2	8/2008	Tain et al.				
7,434,964	B1	10/2008	Zheng et al.				
7,494,249	B2 *	2/2009	Li .....	362/294			
7,513,653	B1 *	4/2009	Liu et al. ....	362/294			
7,568,817	B2 *	8/2009	Lee et al. ....	362/294			
7,637,636	B2 *	12/2009	Zheng et al. ....	362/294			
2004/0026721	A1	2/2004	Dry				
2004/0141326	A1	7/2004	Dry				
2005/0258439	A1	11/2005	Dry				
2005/0258440	A1	11/2005	Dry				
2005/0269581	A1	12/2005	Dry				
2007/0195527	A1	8/2007	Russell				
2007/0253202	A1 *	11/2007	Wu et al. ....	362/294			
2007/0279862	A1 *	12/2007	Li .....	361/692			
2008/0007954	A1 *	1/2008	Li .....	362/294			
2008/0130299	A1 *	6/2008	Dorogi .....	362/373			
2008/0158878	A1	7/2008	Van Laanen et al.				
2008/0285265	A1	11/2008	Boissevain				
2008/0316755	A1	12/2008	Zheng et al.				
2009/0040759	A1 *	2/2009	Zhang et al. ....	362/249			
2009/0073688	A1	3/2009	Patrick				
2009/0116233	A1 *	5/2009	Zheng et al. ....	362/234			
2009/0262530	A1	10/2009	Tickner et al.				

\* cited by examiner

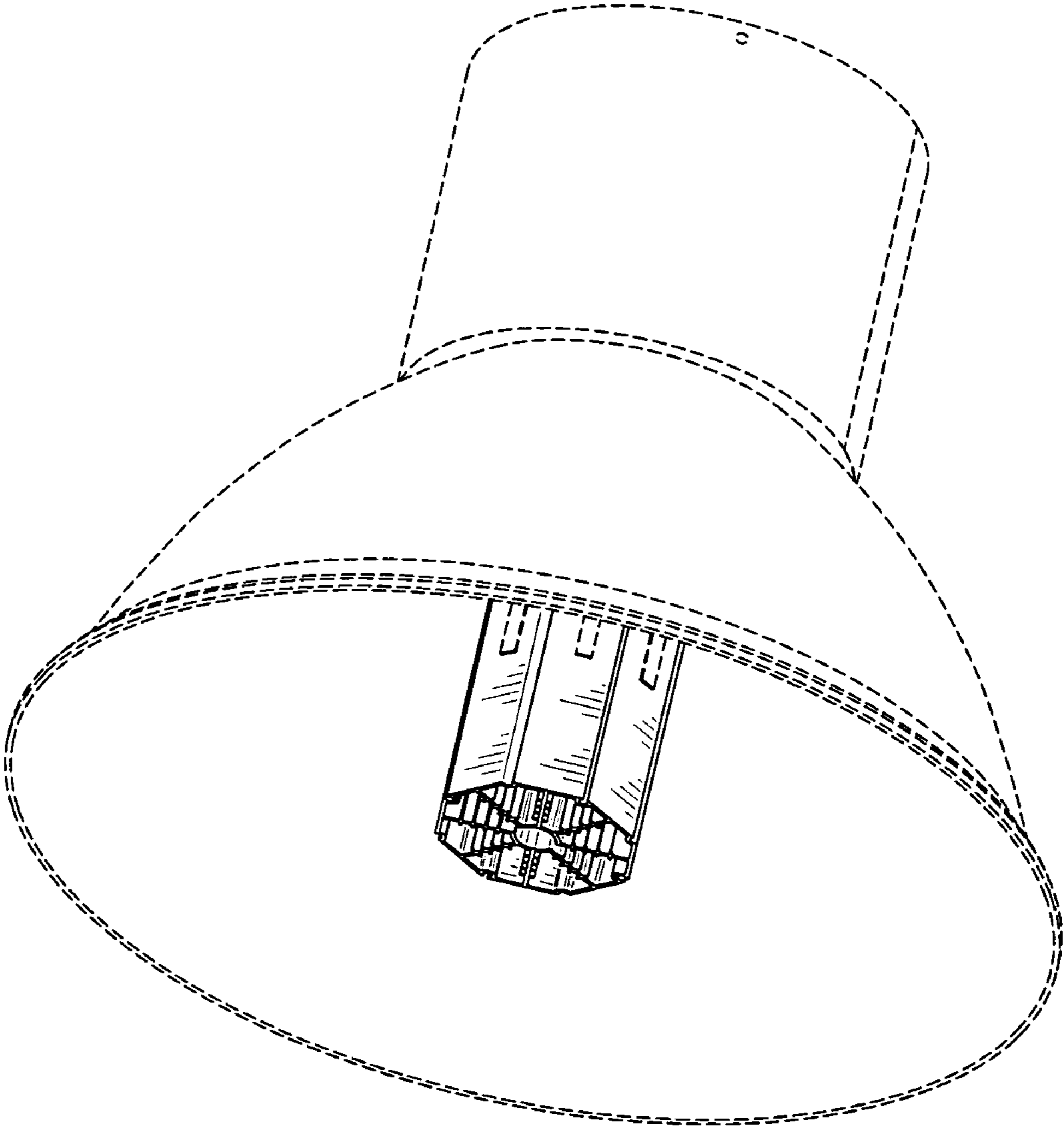

FIG. 1

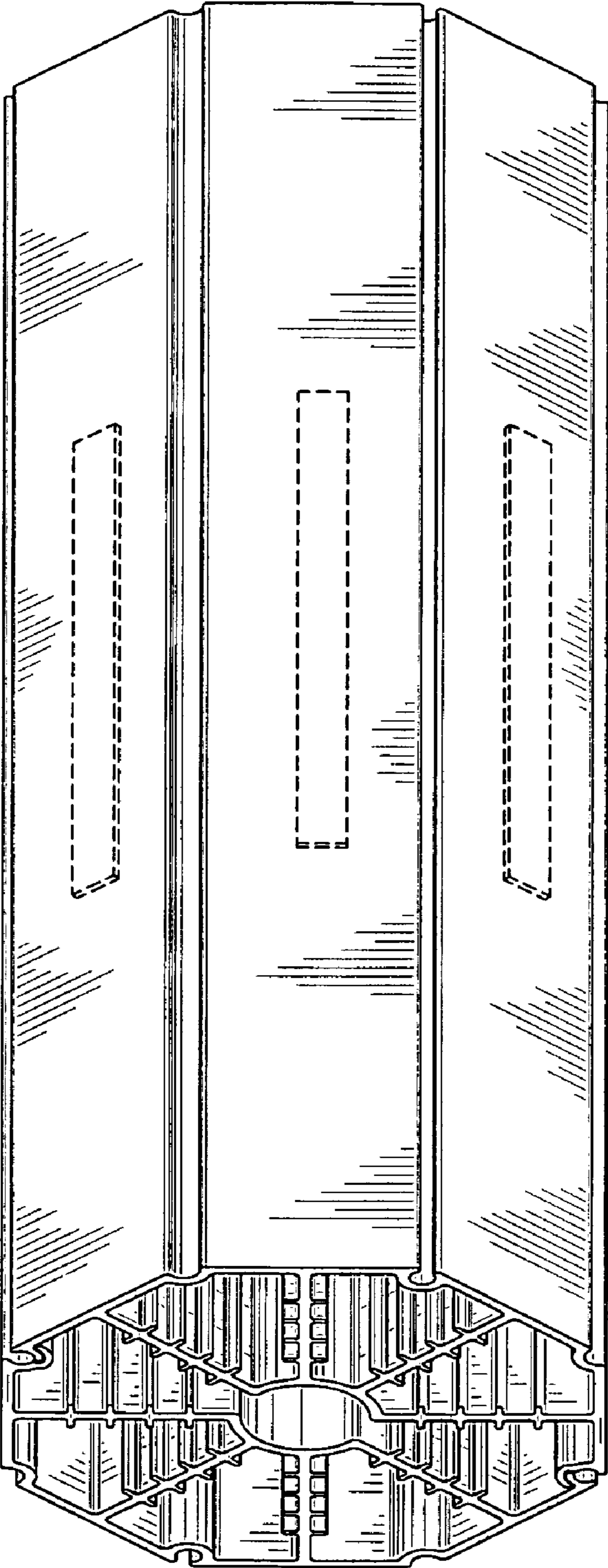

FIG. 2

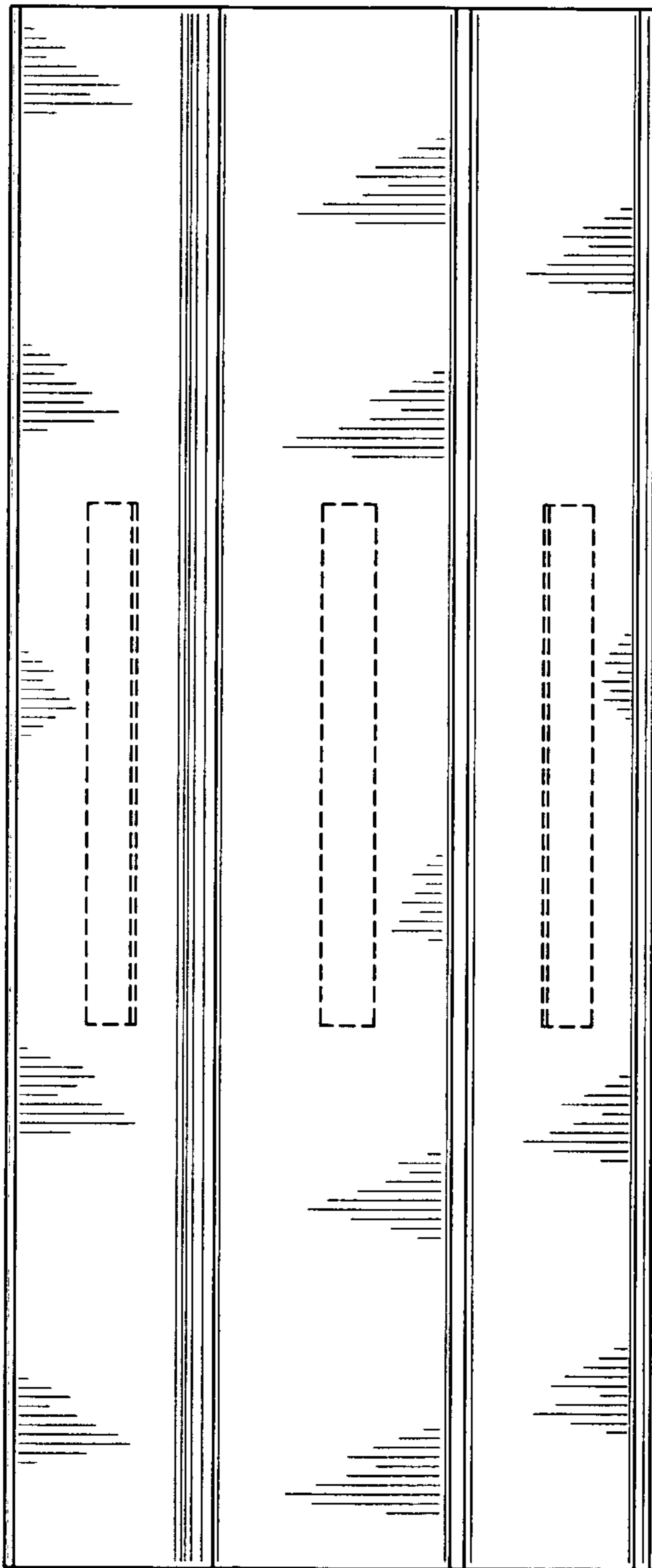

FIG. 3

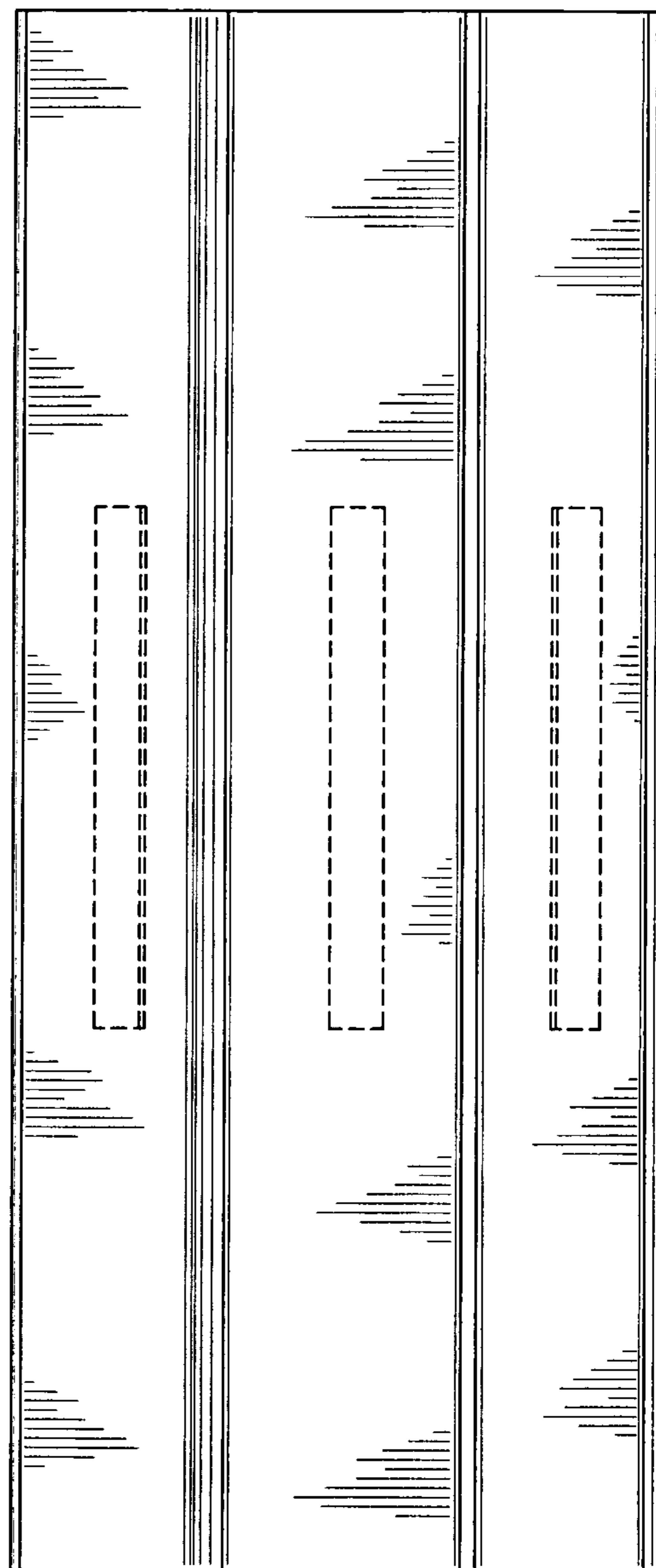

FIG. 4

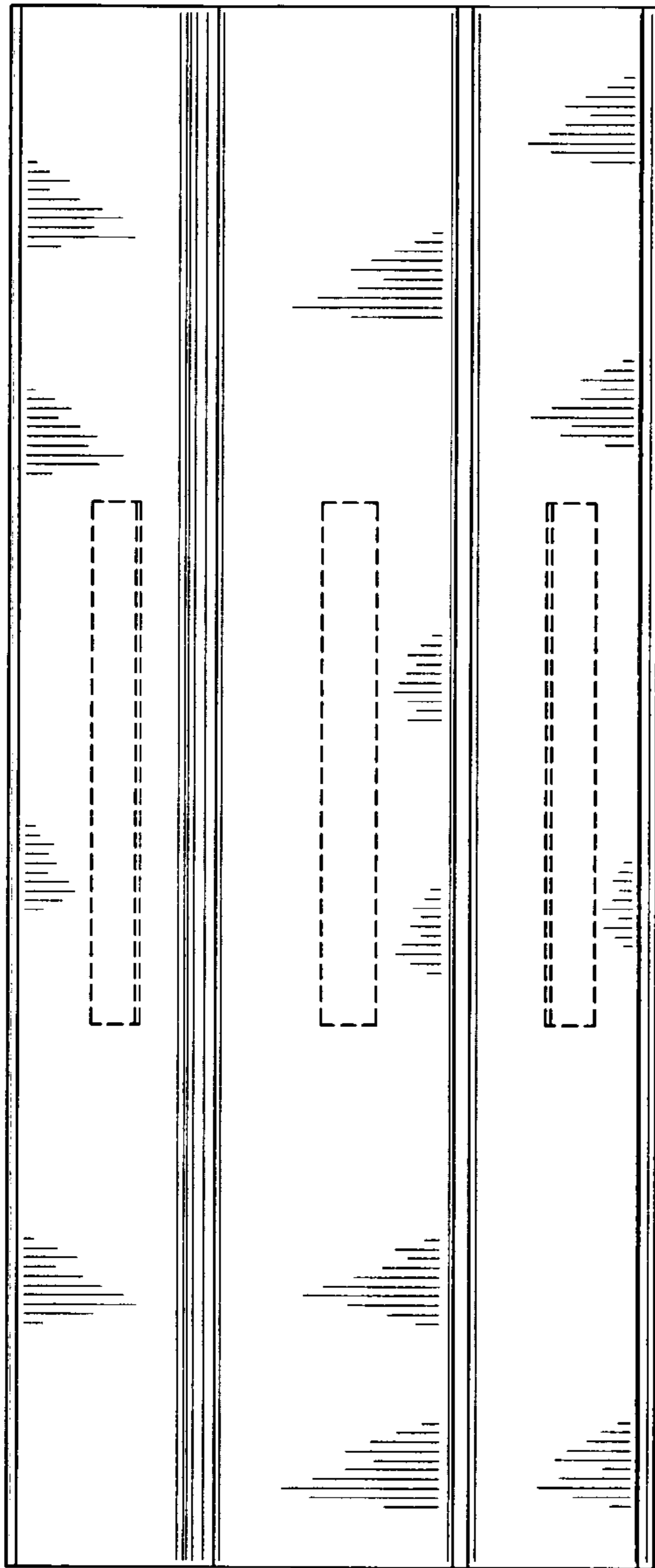

FIG. 5

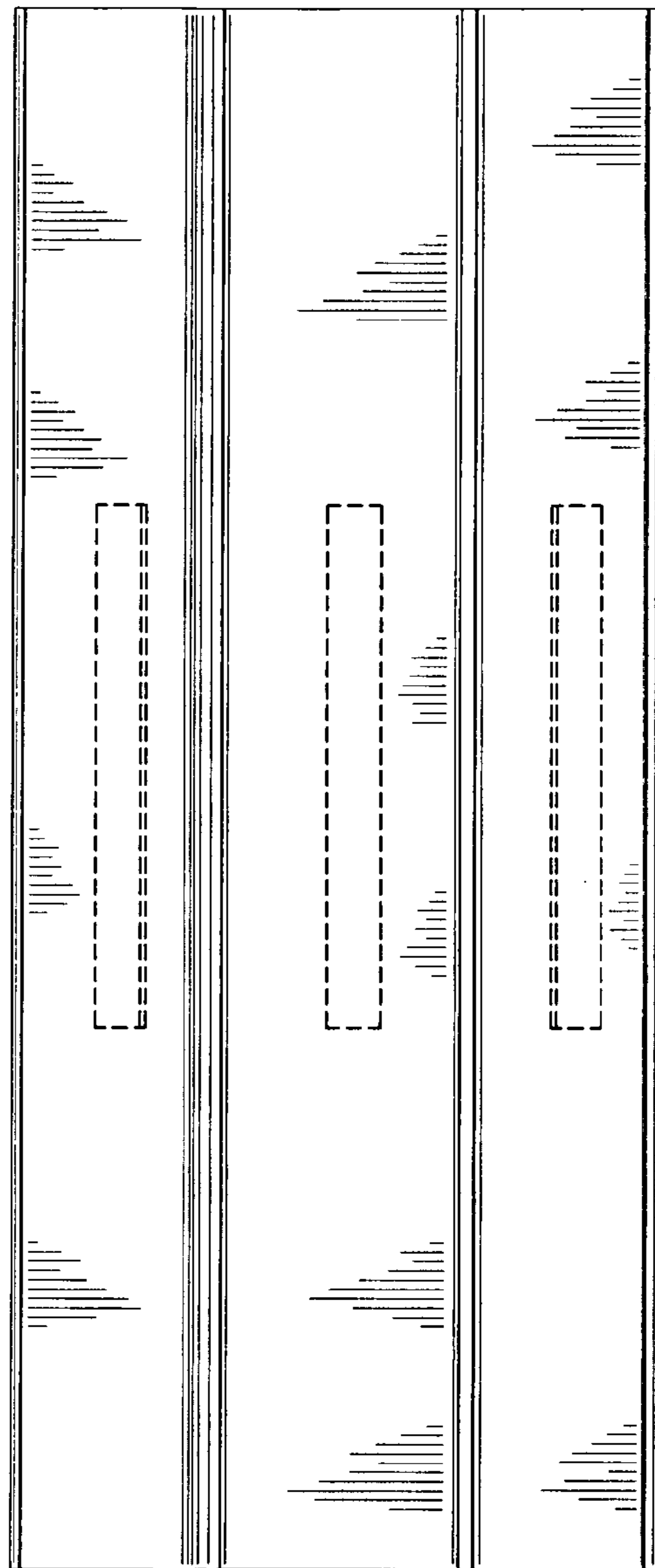

FIG. 6

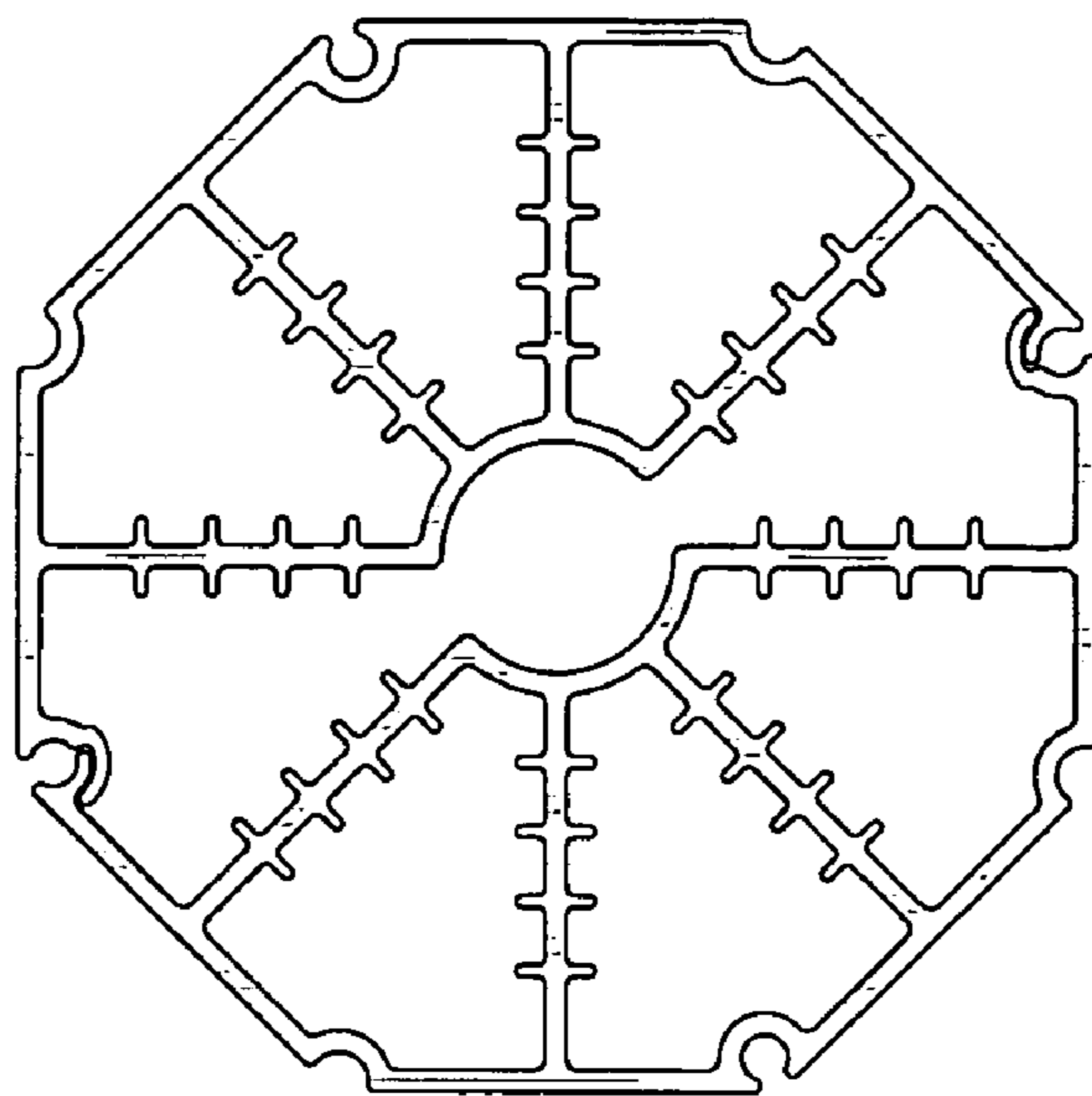

FIG. 7

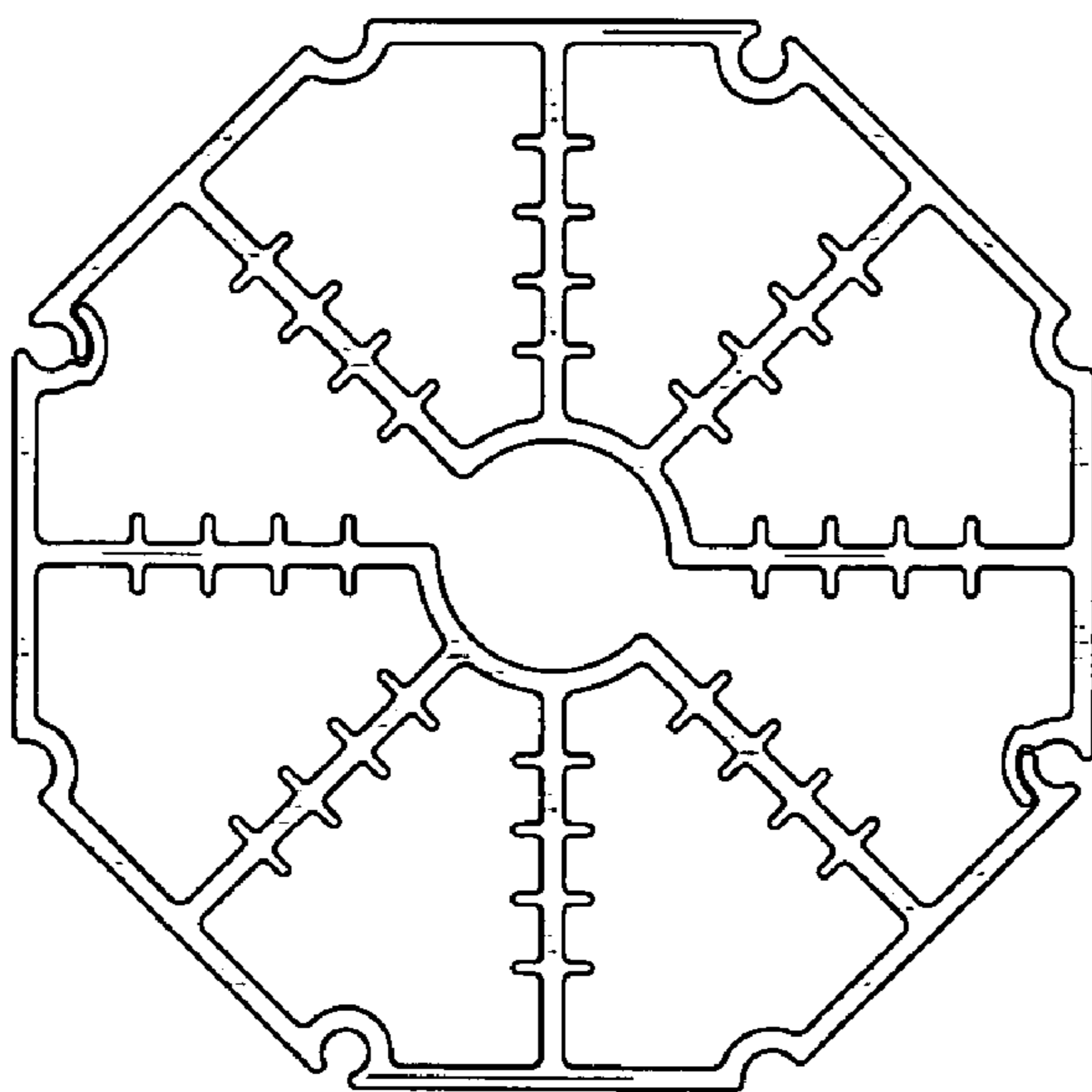

FIG. 8