



US00D617383S

(12) **United States Design Patent**  
**Yoon**

(10) **Patent No.:** **US D617,383 S**  
(45) **Date of Patent:** **\*\* Jun. 8, 2010**

(54) **DISPLAY STAND FOR WRITING TOOLS**

(75) Inventor: **Hyun-son Yoon**, Seoul (KR)

(73) Assignee: **Morris Corporation**, Incheon-shi (KR)

(\*\*) Term: **14 Years**

(21) Appl. No.: **29/338,818**

(22) Filed: **Jun. 18, 2009**

(51) **LOC (9) Cl.** ..... **19-06**

(52) **U.S. Cl.** ..... **D19/85**

(58) **Field of Classification Search** ..... D3/206,  
D3/310, 313; D7/606, 624.2, 625; D9/741,  
D9/747, 779; D19/75, 77-86, 90-95; D34/1;  
206/214, 224, 371, 457; 211/69.1-69.9,  
211/70

See application file for complete search history.

(56) **References Cited**

**U.S. PATENT DOCUMENTS**

226,645	A *	4/1880	Albaugh	.....	211/129.1
254,006	A *	2/1882	Hake	.....	47/41.11
2,496,758	A *	2/1950	Tingley	.....	47/41.13
D214,768	S *	7/1969	Hillis	.....	D19/23
D279,950	S *	8/1985	Wan	.....	D7/640
4,534,474	A *	8/1985	Ng	.....	211/70
4,819,794	A *	4/1989	Silverstein et al.	.....	206/225
D340,071	S *	10/1993	Sun	.....	D19/77
D367,408	S *	2/1996	Fordyce	.....	D7/703

D396,749	S *	8/1998	Ortiz	.....	D3/284
D418,947	S *	1/2000	Greiner	.....	D28/73
D433,066	S *	10/2000	Porter	.....	D19/90
D436,705	S *	1/2001	Dow et al.	.....	D34/5
D490,978	S *	6/2004	Breyer	.....	D3/313
6,942,109	B2 *	9/2005	Aros et al.	.....	211/58
D575,986	S *	9/2008	Cetera	.....	D7/501
D583,870	S *	12/2008	Allen et al.	.....	D19/85
2009/0218240	A1 *	9/2009	Allen et al.	.....	206/214

\* cited by examiner

*Primary Examiner*—Elizabeth A Albert

(74) *Attorney, Agent, or Firm*—Intellectual Property Law Group LLP; Juneko Jackson; Otto O. Lee

(57) **CLAIM**

The ornamental design for a display stand for writing tools, as shown and described.

**DESCRIPTION**

FIG. 1 is a top perspective view of a display stand for writing tools embodying my new design;

FIG. 2 is a bottom perspective view thereof;

FIG. 3 is a front elevational view thereof;

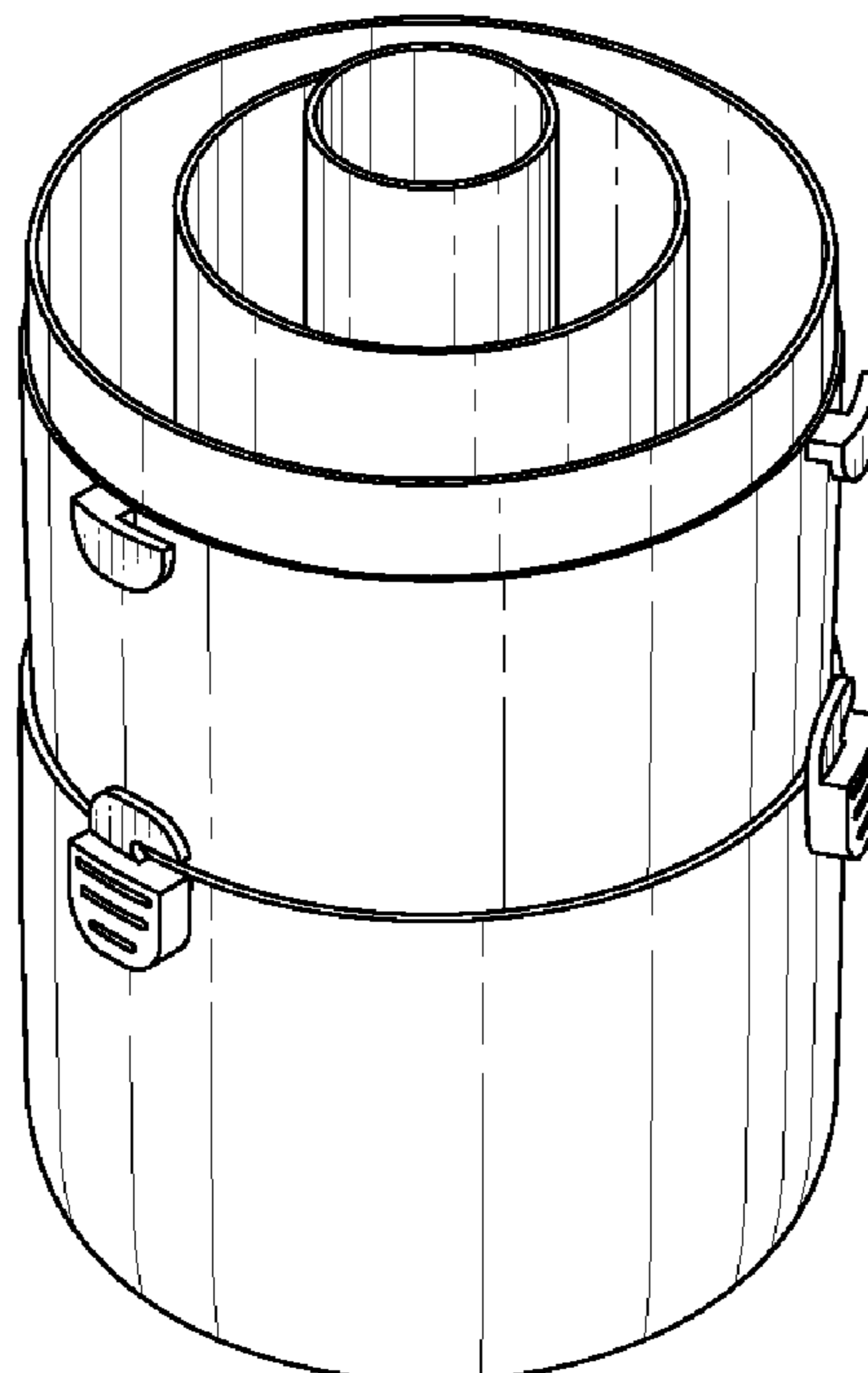
FIG. 4 is a rear elevational view thereof;

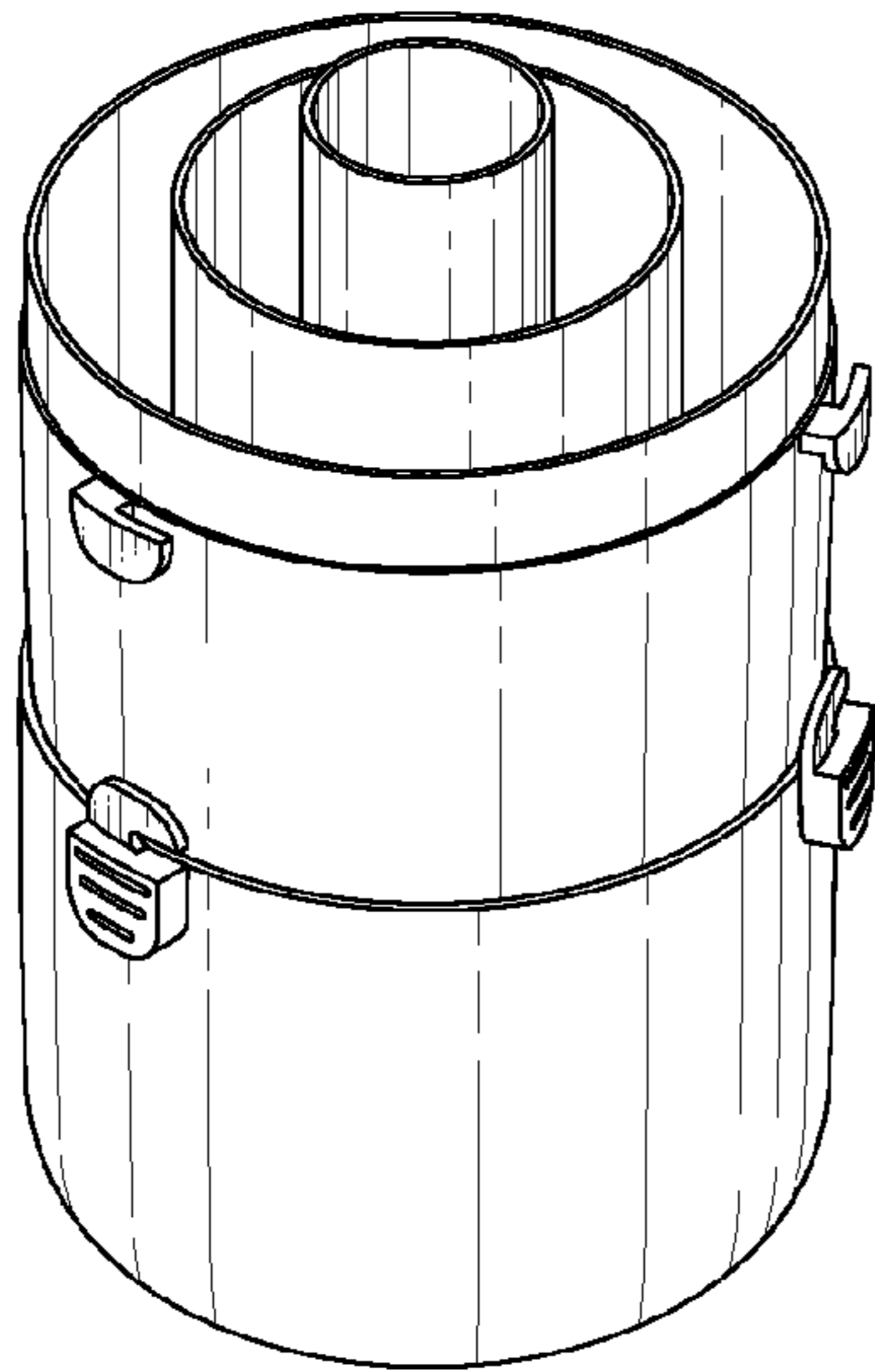
FIG. 5 is a left side elevational view thereof;

FIG. 6 is a right side elevational view thereof; and,

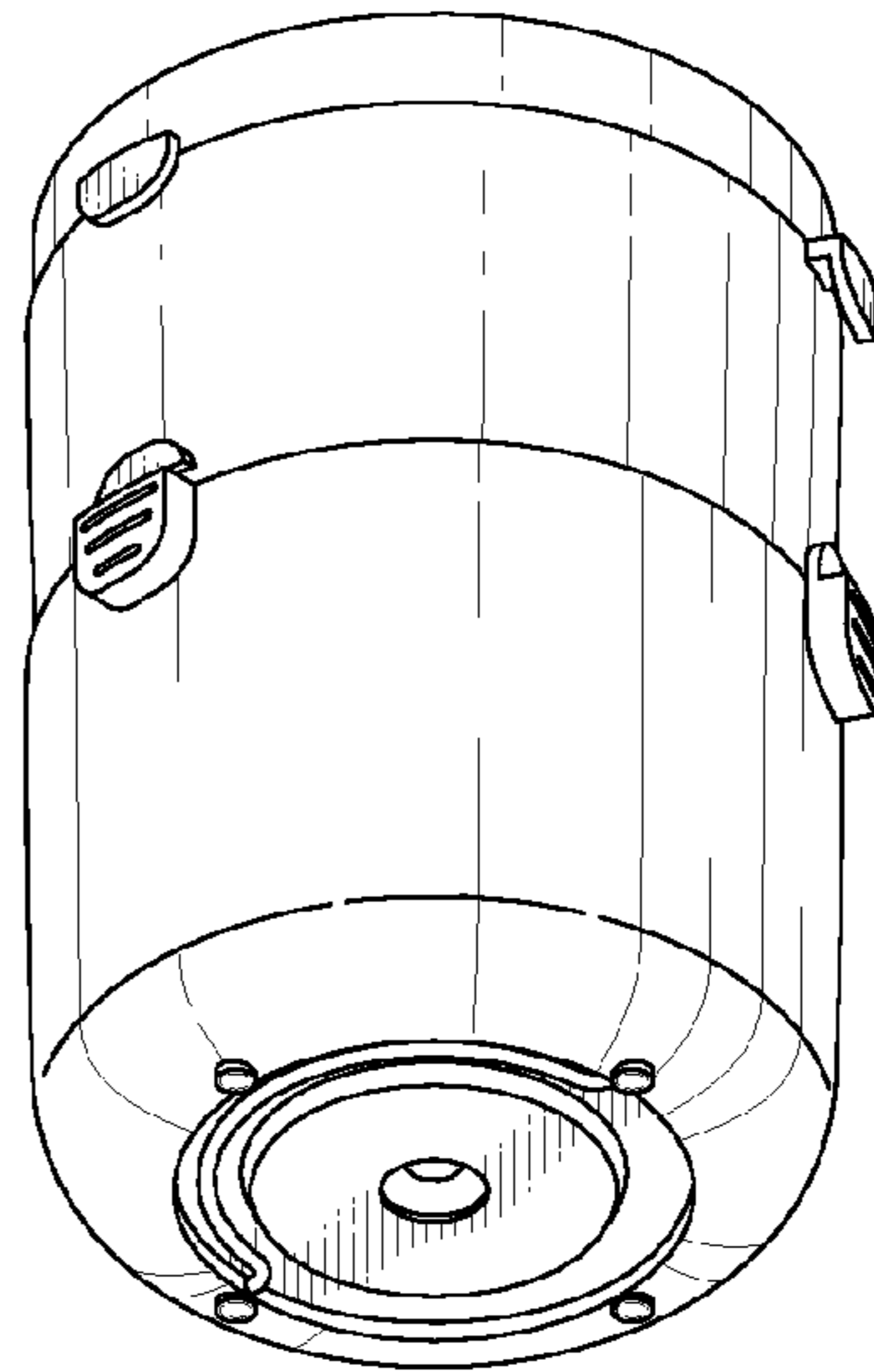
FIG. 7 is a bottom plan view thereof.

**1 Claim, 2 Drawing Sheets**

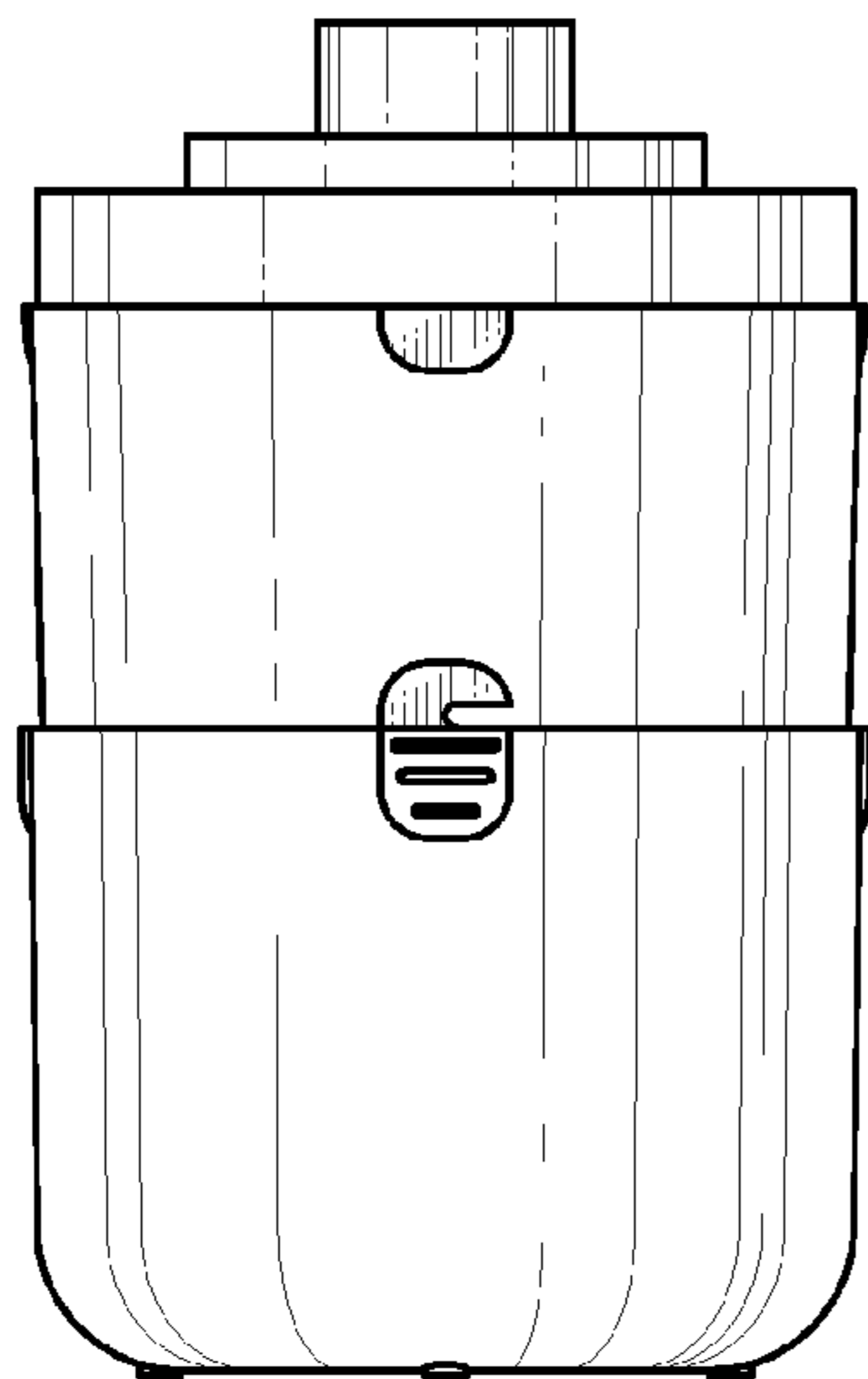




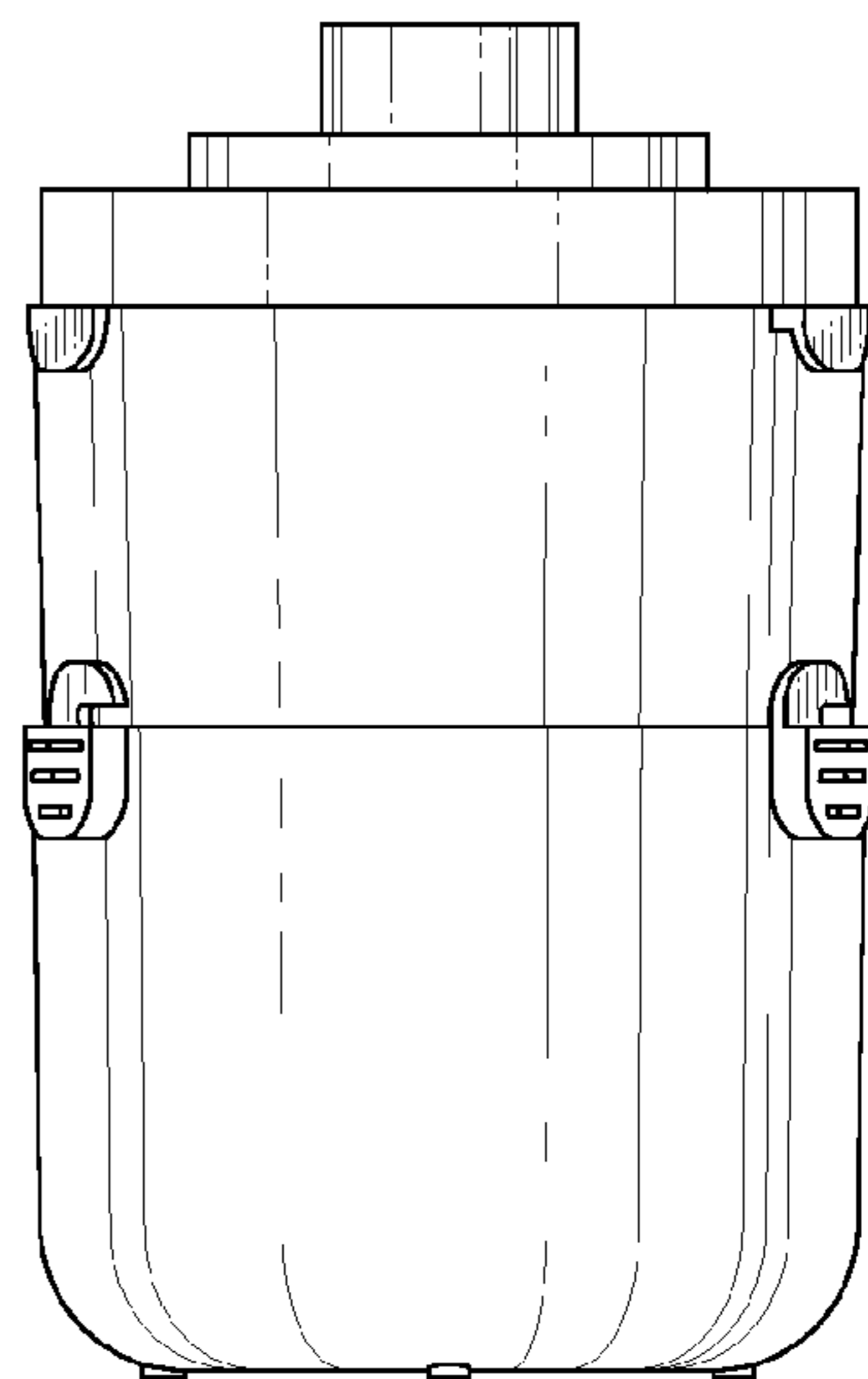
**FIG. 1**



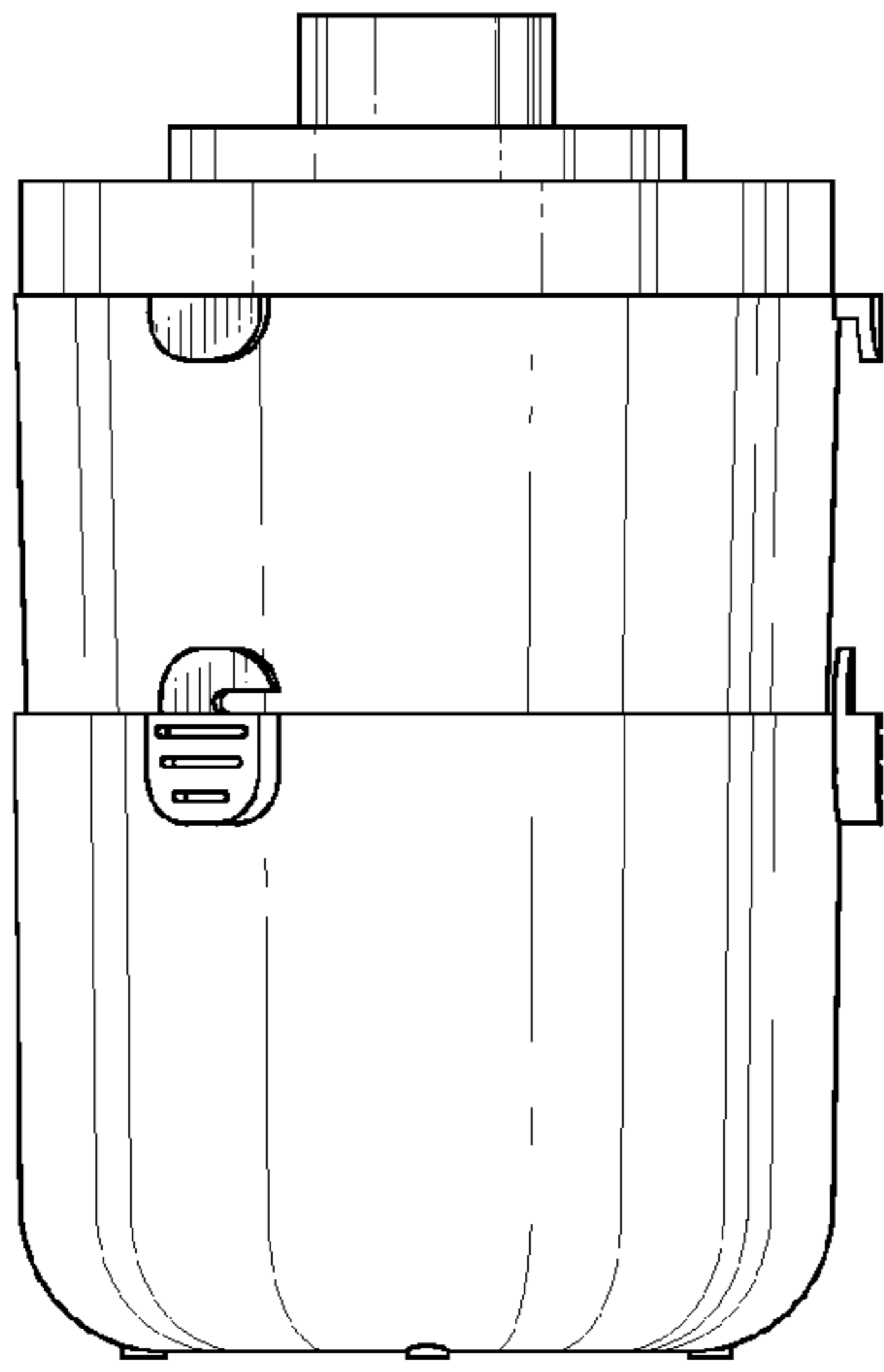
**FIG. 2**



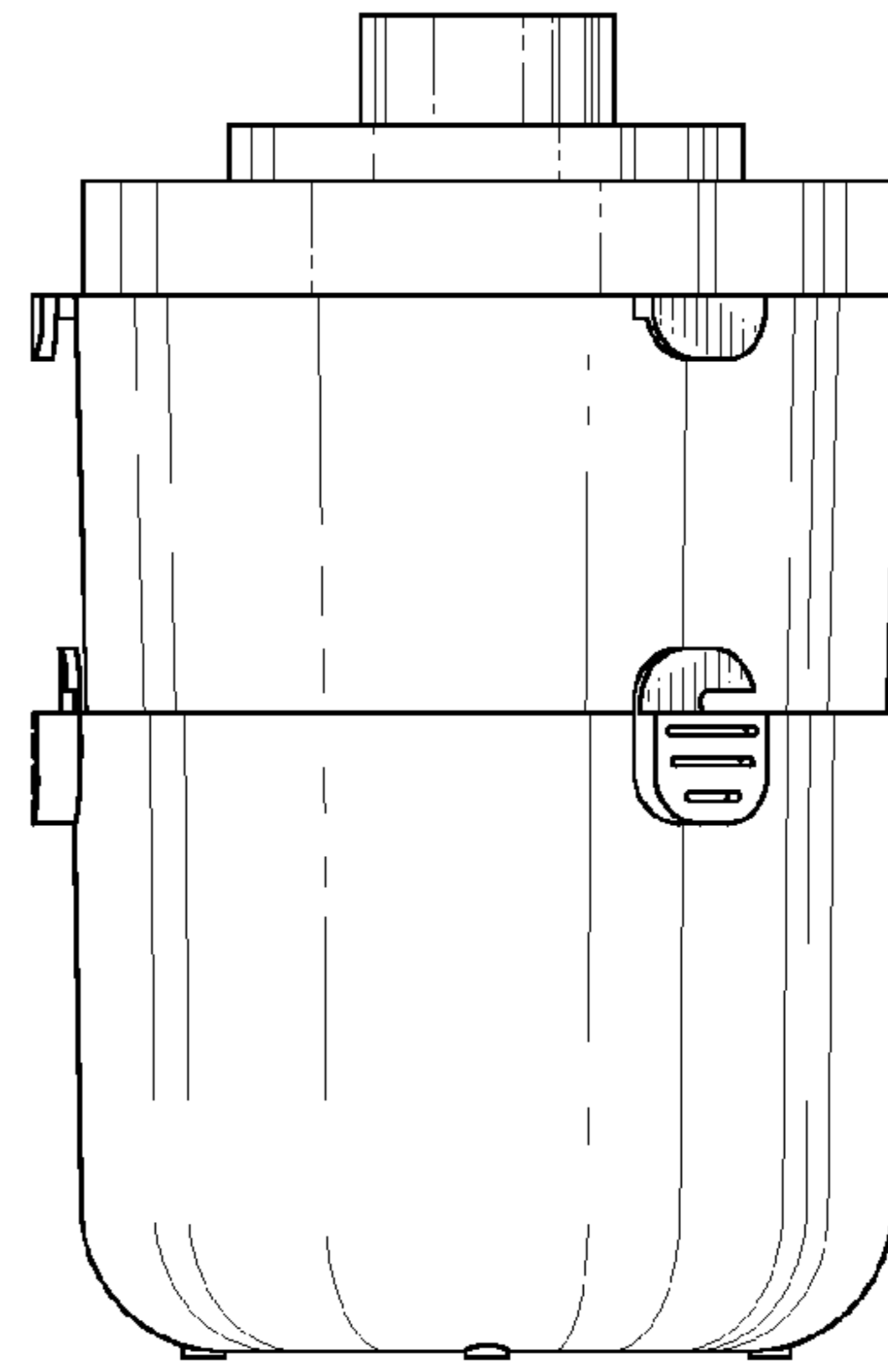
**FIG. 3**



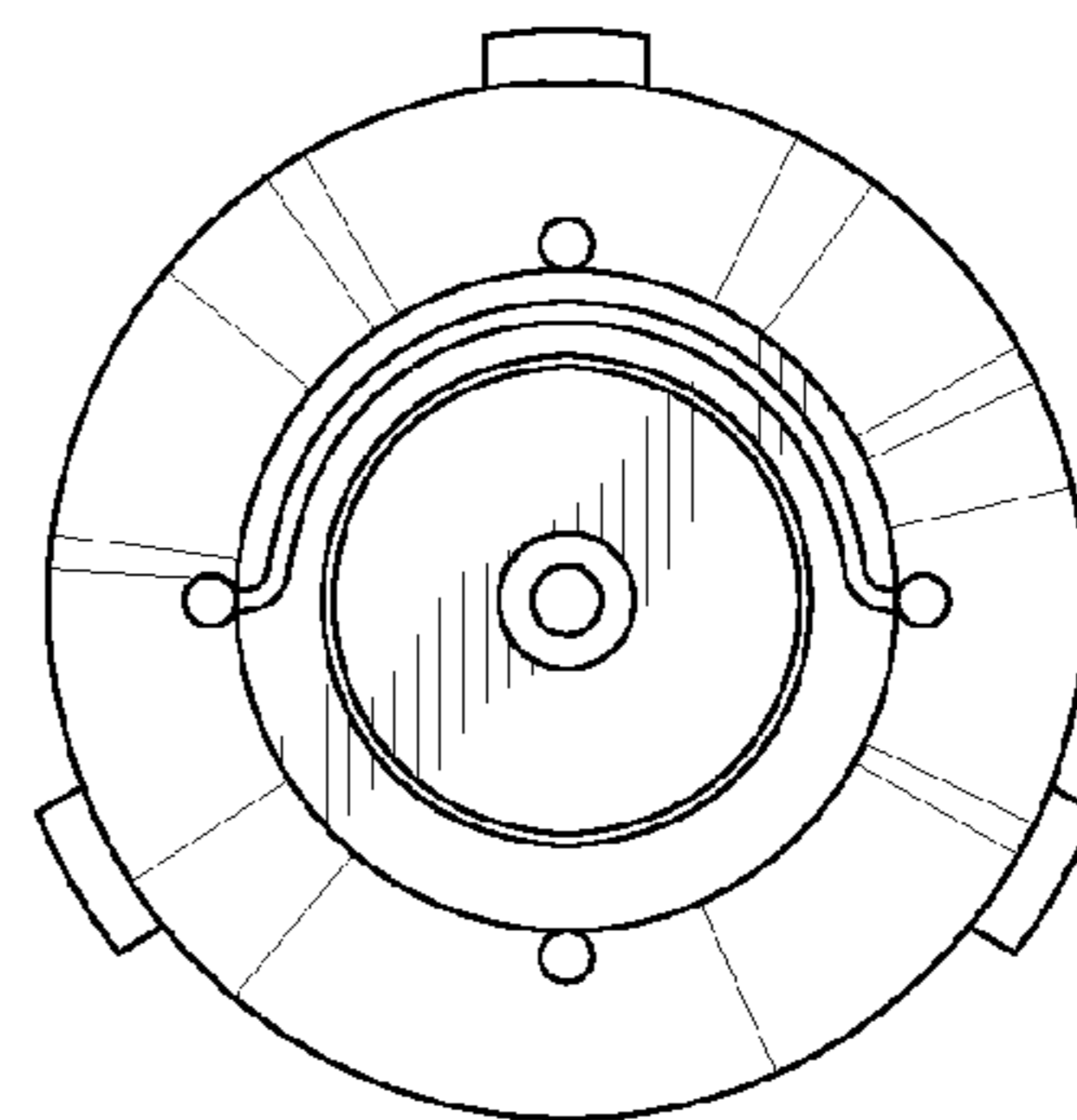
**FIG. 4**



**FIG. 5**



**FIG. 6**



**FIG. 7**