



US00D617270S

(12) **United States Design Patent**  
**Mai**

(10) **Patent No.:** **US D617,270 S**

(45) **Date of Patent:** **\*\* Jun. 8, 2010**

(54) **BATTERY CONNECTOR**

(75) Inventor: **Yuan Li Mai**, Tu-Cheng (TW)

(73) Assignee: **Cheng Uei Precision Industry Co., Ltd.**, Taipei Hsien (TW)

(\*\*) Term: **14 Years**

(21) Appl. No.: **29/311,590**

(22) Filed: **Apr. 24, 2009**

(51) **LOC (9) Cl.** ..... **13-03**

(52) **U.S. Cl.** ..... **D13/120**

(58) **Field of Classification Search** ..... D13/118-121,  
D13/133, 146-147, 184, 199; 439/83, 108,  
439/166, 500, 577, 630, 660, 680, 700, 773.1,  
439/862

See application file for complete search history.

(56) **References Cited**

U.S. PATENT DOCUMENTS

6,361,359	B1 *	3/2002	Du et al.	.....	439/500
D486,448	S *	2/2004	Watanabe et al.	.....	D13/120
D559,180	S *	1/2008	Lai et al.	.....	D13/120
D559,181	S *	1/2008	Yan	.....	D13/120
D561,100	S *	2/2008	Hsu et al.	.....	D13/120
D562,241	S *	2/2008	Hsu et al.	.....	D13/146

D562,251	S *	2/2008	Ma et al.	.....	D13/147
D563,322	S *	3/2008	Ma	.....	D13/146
D591,676	S *	5/2009	Hung	.....	D13/120
D593,490	S *	6/2009	Hung	.....	D13/120
D605,117	S *	12/2009	Mai et al.	.....	D13/120
D605,118	S *	12/2009	Mai et al.	.....	D13/120
2004/0161979	A1 *	8/2004	Kyowski et al.	.....	439/660

\* cited by examiner

*Primary Examiner*—Rosemary K Tarcza

(74) *Attorney, Agent, or Firm*—Rosenberg, Klein & Lee

(57) **CLAIM**

The ornamental design for a battery connector, as shown and described.

**DESCRIPTION**

FIG. 1 is a perspective view of a battery connector showing my new design;

FIG. 2 is a front elevational view thereof;

FIG. 3 is a rear elevational view thereof;

FIG. 4 is a left side elevational view thereof;

FIG. 5 is a right side elevational view thereof;

FIG. 6 is a top plan view thereof; and,

FIG. 7 is a bottom plan view thereof.

**1 Claim, 7 Drawing Sheets**

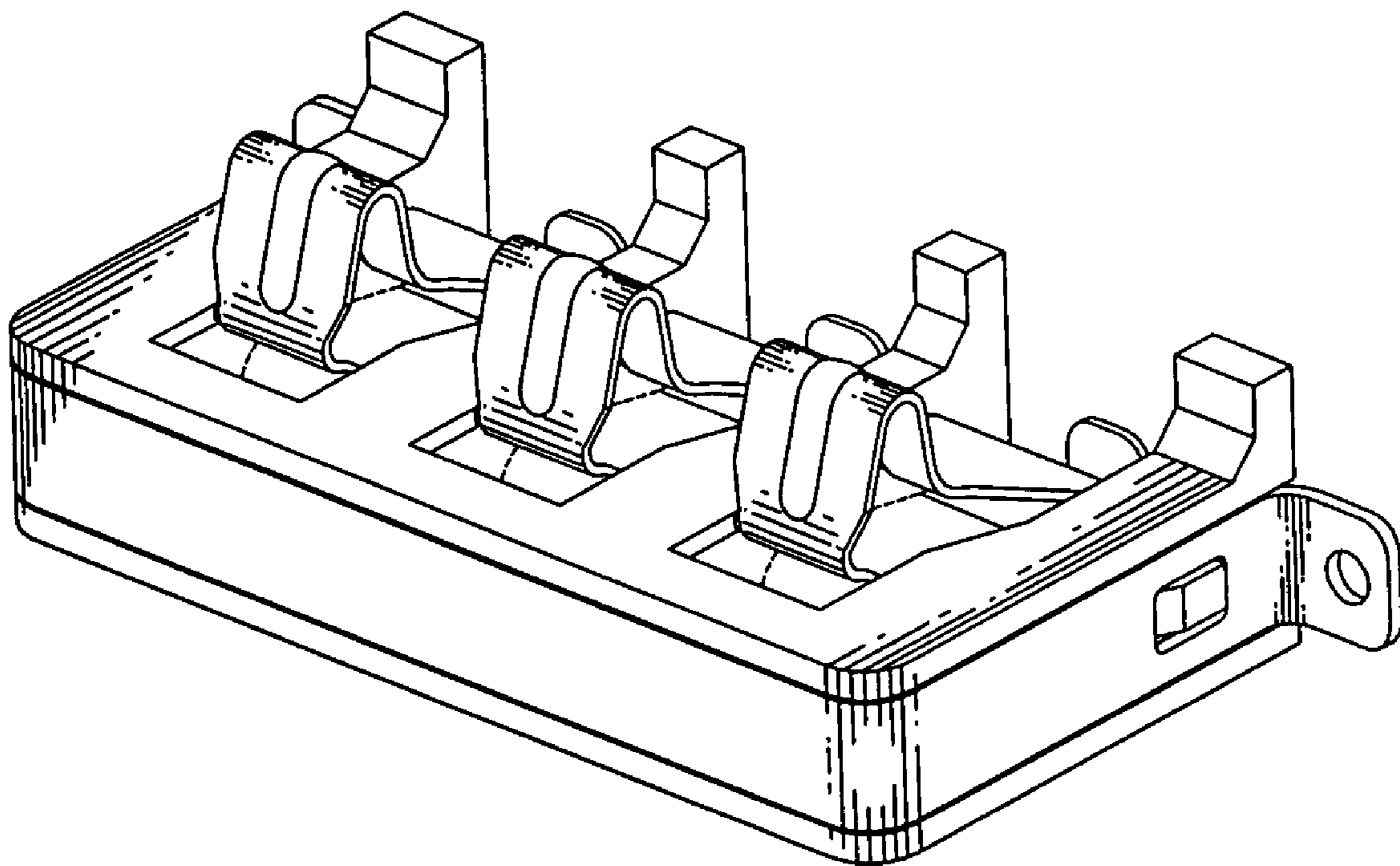

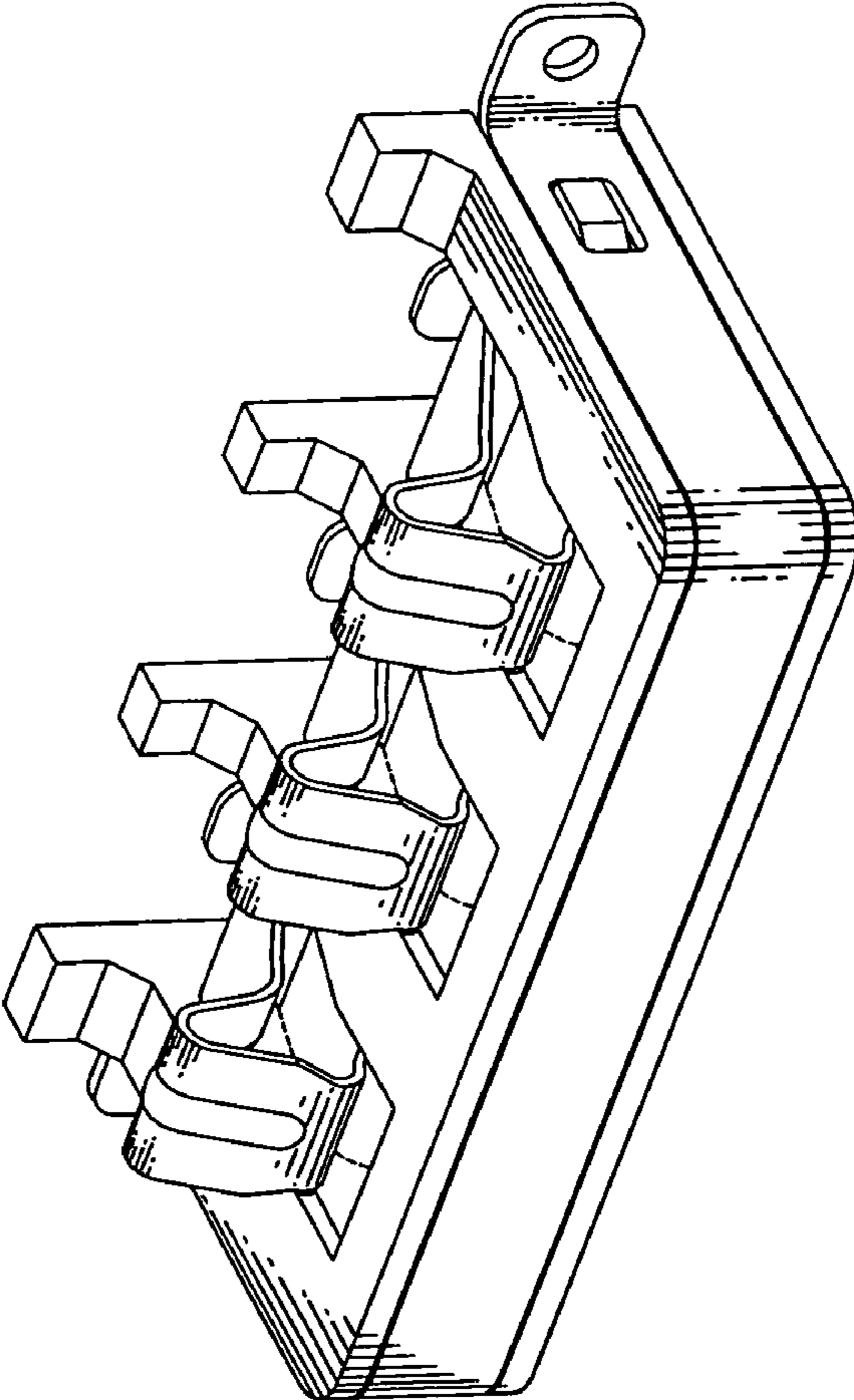

FIG. 1

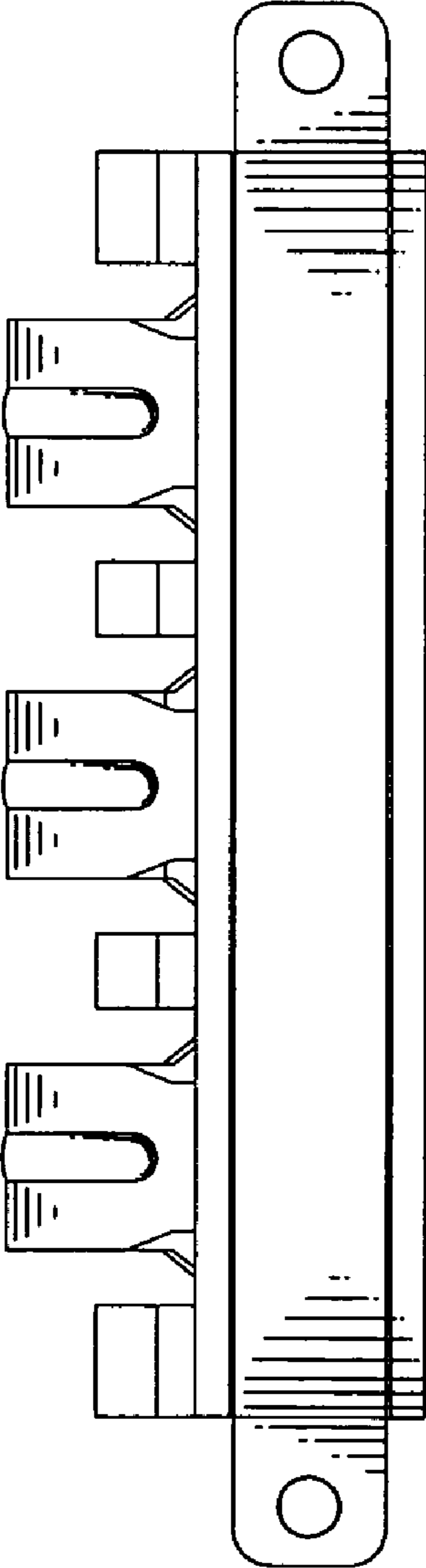

FIG. 2

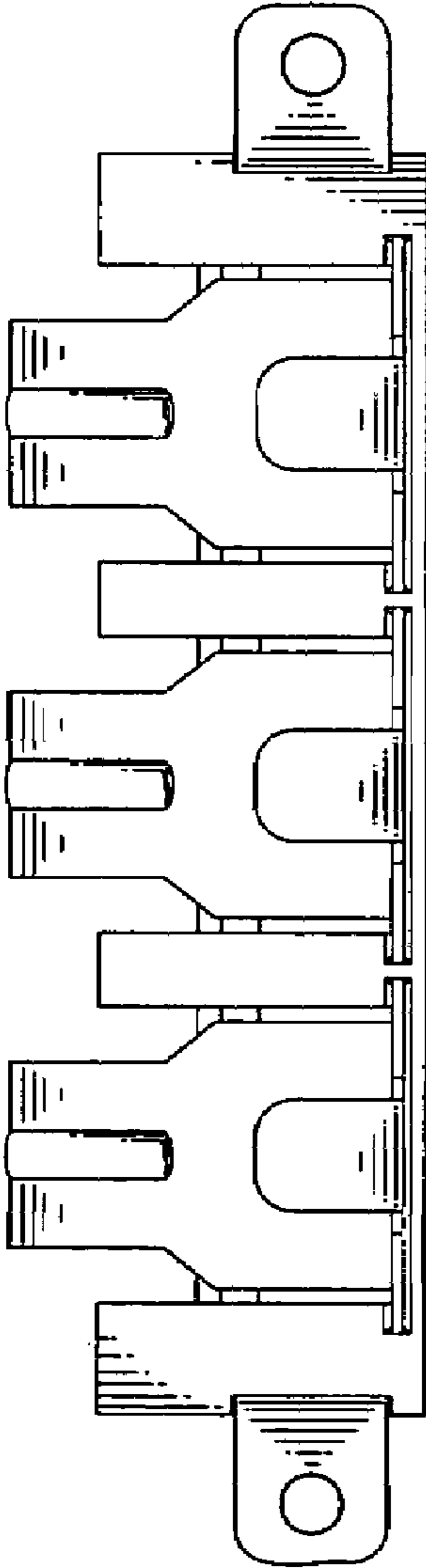

FIG. 3

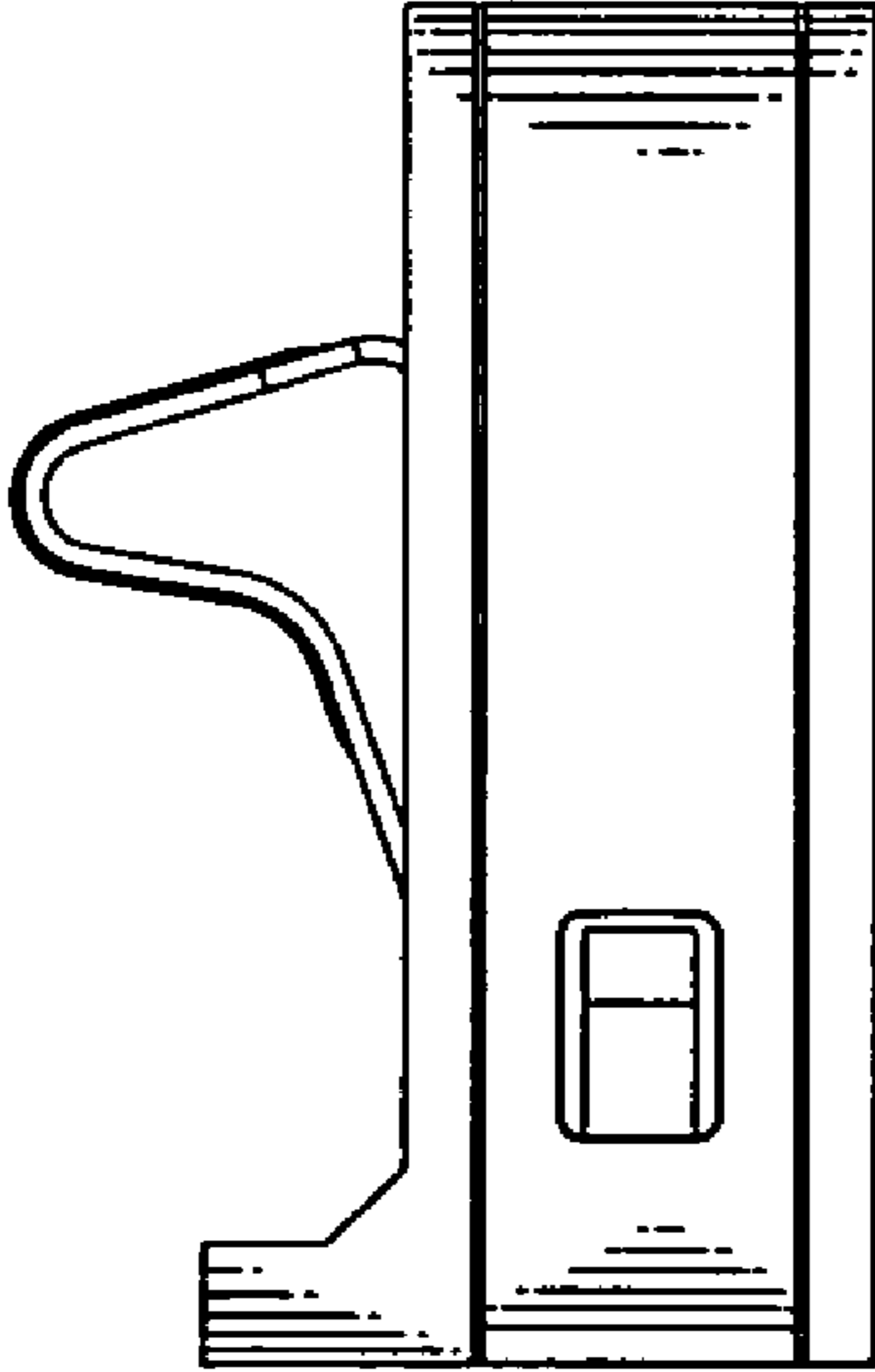

FIG. 4

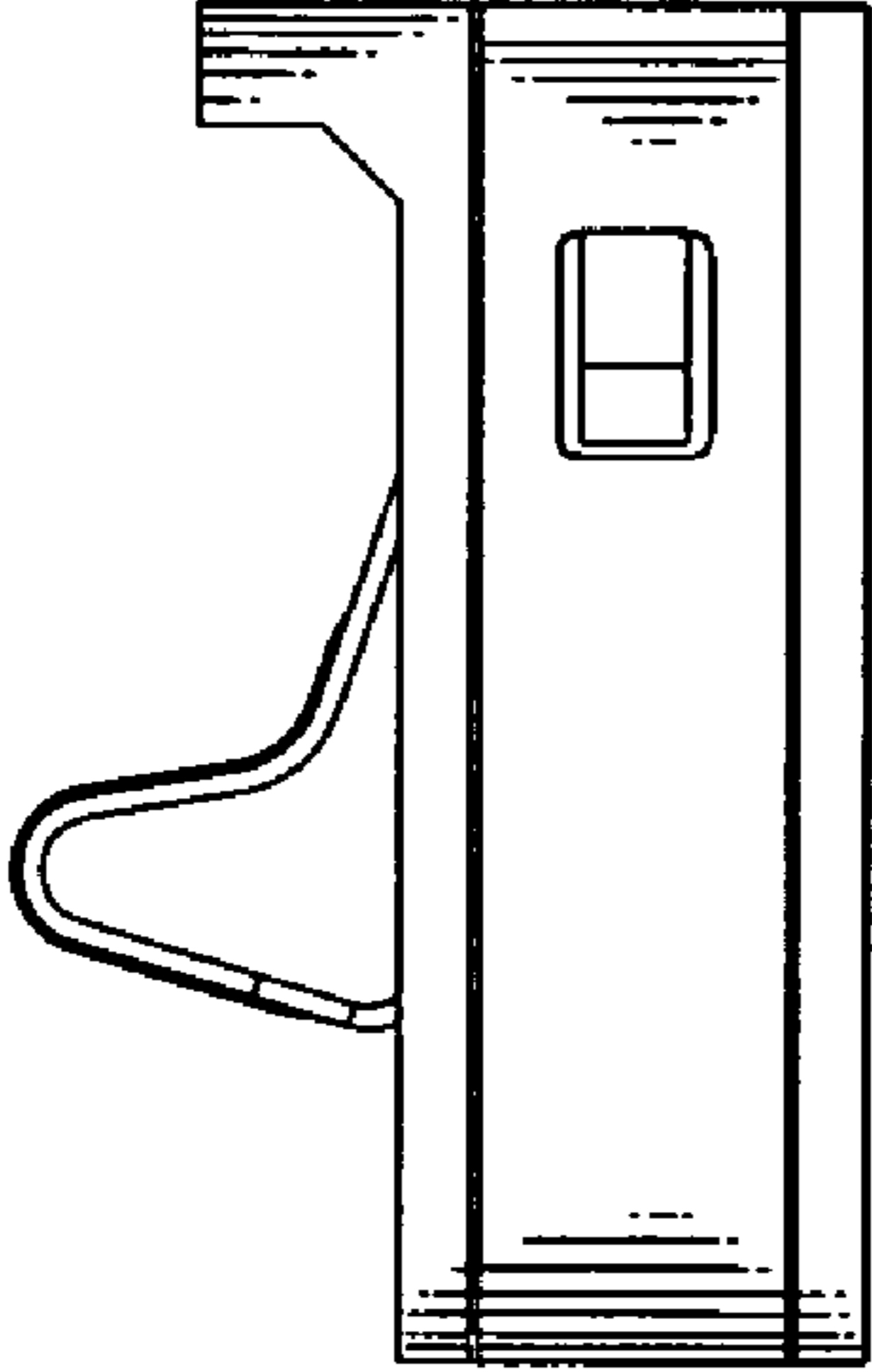

FIG. 5

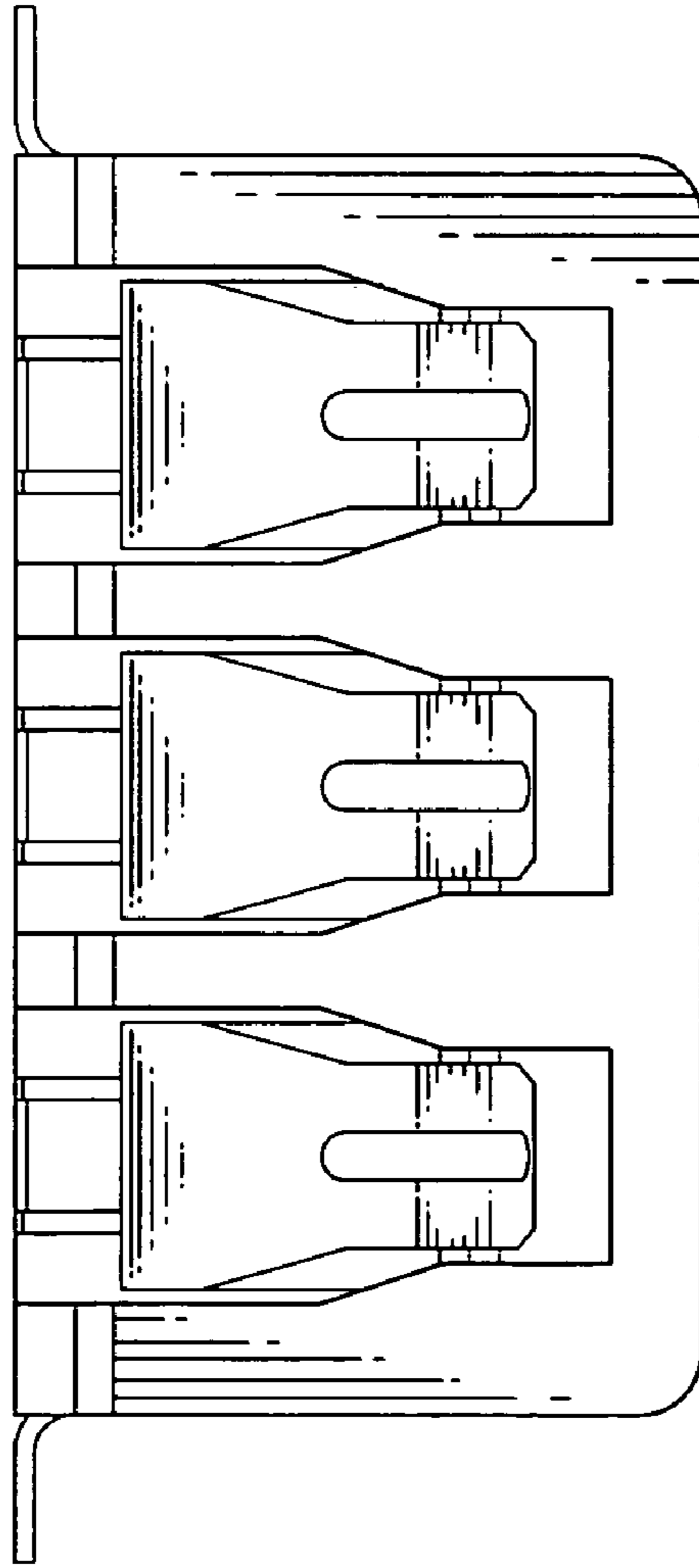

FIG. 6

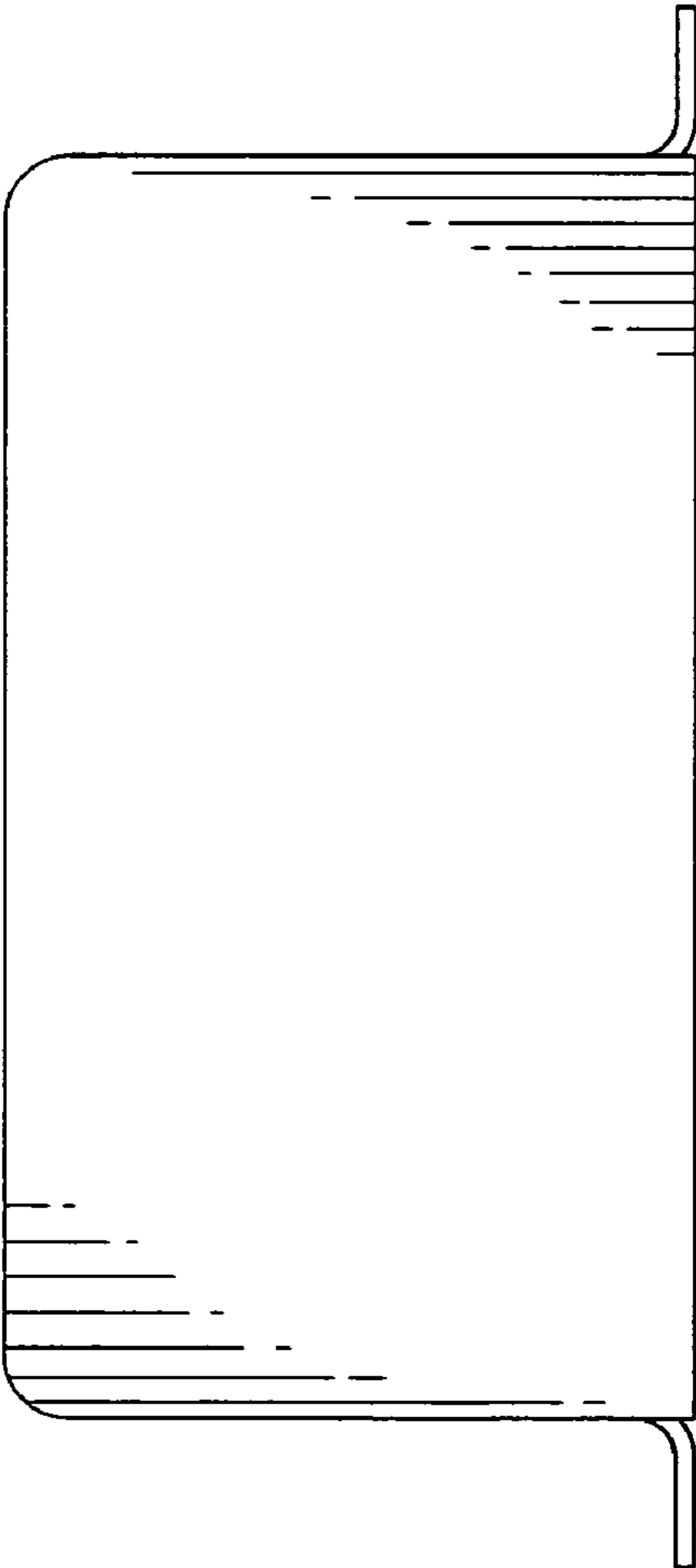

FIG. 7