



US00D616941S

(12) **United States Design Patent**  
**Bradfield**

(10) **Patent No.:** **US D616,941 S**

(45) **Date of Patent:** **\*\* Jun. 1, 2010**

(54) **TAPE DISPENSER**

(75) Inventor: **Richard M. Bradfield**, Easter Cape  
(ZA)

(73) Assignee: **Precision Laboratories, Inc.**,  
Cottonwood, AZ (US)

(\*\*) Term: **14 Years**

(21) Appl. No.: **29/353,893**

(22) Filed: **Jan. 15, 2010**

(51) **LOC (9) Cl.** ..... **08-05**

(52) **U.S. Cl.** ..... **D19/69**

(58) **Field of Classification Search** ..... D19/69,  
D19/70, 36, 68; 242/588.6, 588.2; 225/77,  
225/6, 56, 39, 26, 19, 11, 34; 206/411; 156/577,  
156/527, 523

See application file for complete search history.

(56) **References Cited**

**U.S. PATENT DOCUMENTS**

2,275,212	A *	3/1942	Valentine	.....	242/608.7
2,678,777	A *	5/1954	Donkin	.....	225/19
2,681,186	A *	6/1954	Slawik	.....	225/44
2,694,533	A *	11/1954	Zucker	.....	242/588.6
2,699,251	A *	1/1955	Rizza	.....	225/34
2,790,609	A *	4/1957	Hawthorne et al.	.....	225/26
D194,756	S *	3/1963	Norman	.....	D6/518
3,216,634	A *	11/1965	Lausa	.....	225/19
D289,862	S *	5/1987	Reisgies et al.	.....	D10/94
D291,843	S *	9/1987	Searle	.....	D3/302
D319,665	S *	9/1991	Kiyokane	.....	D19/69
D323,531	S *	1/1992	Fortune	.....	D19/69
D324,997	S *	3/1992	Jones	.....	D9/529

D340,625	S *	10/1993	Wang	.....	D7/629
D361,087	S *	8/1995	van Eijben et al.	.....	D19/69
D382,175	S *	8/1997	Green	.....	D7/538
5,698,067	A *	12/1997	Packard	.....	156/577
5,735,400	A *	4/1998	Packard	.....	206/408
D431,458	S *	10/2000	Bried et al.	.....	D3/203.2
D472,319	S *	3/2003	Oltmann	.....	D24/189
D484,795	S *	1/2004	Barnes et al.	.....	D9/414
D568,692	S *	5/2008	Lam	.....	D7/629
D586,675	S *	2/2009	Wagner et al.	.....	D10/72
D586,676	S *	2/2009	Wagner et al.	.....	D10/72
D590,444	S *	4/2009	Farnworth et al.	.....	D19/73
D592,249	S *	5/2009	Chang	.....	D19/69

\* cited by examiner

*Primary Examiner*—Cathron C Brooks

*Assistant Examiner*—Austin Murphy

(74) *Attorney, Agent, or Firm*—Ladas & Parry LLP

(57) **CLAIM**

The ornamental design for a tape dispenser, as shown and described.

**DESCRIPTION**

FIG. 1 is a front, left side quarter perspective view of a tape dispenser having the design;

FIG. 2 is a top plan view thereof;

FIG. 3 is a right side elevation view thereof;

FIG. 4 is a bottom plan view thereof;

FIG. 5 is a left side elevation view thereof;

FIG. 6 is a front elevation view thereof; and,

FIG. 7 is a rear elevation view thereof.

**1 Claim, 4 Drawing Sheets**

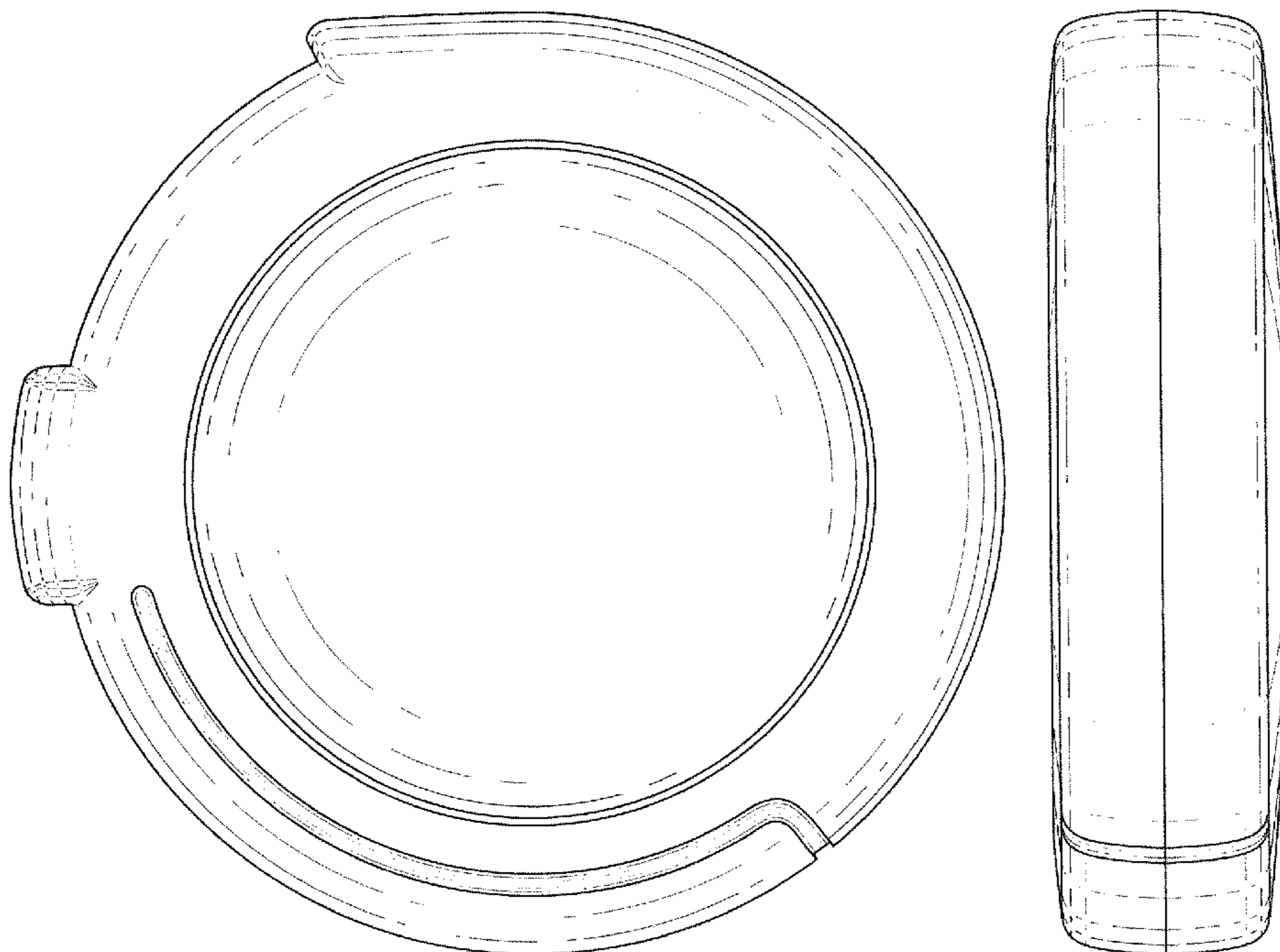

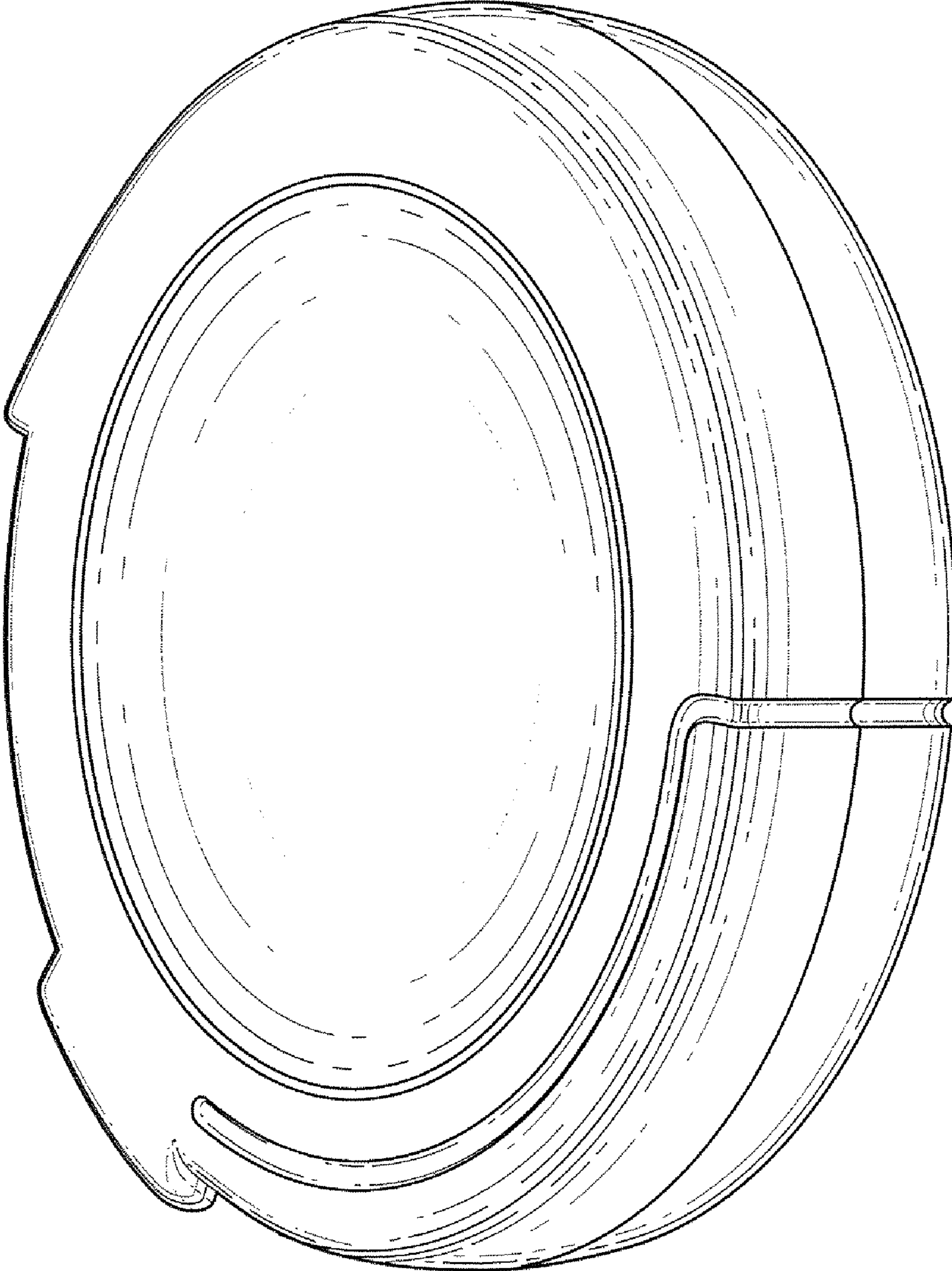

FIG. 1

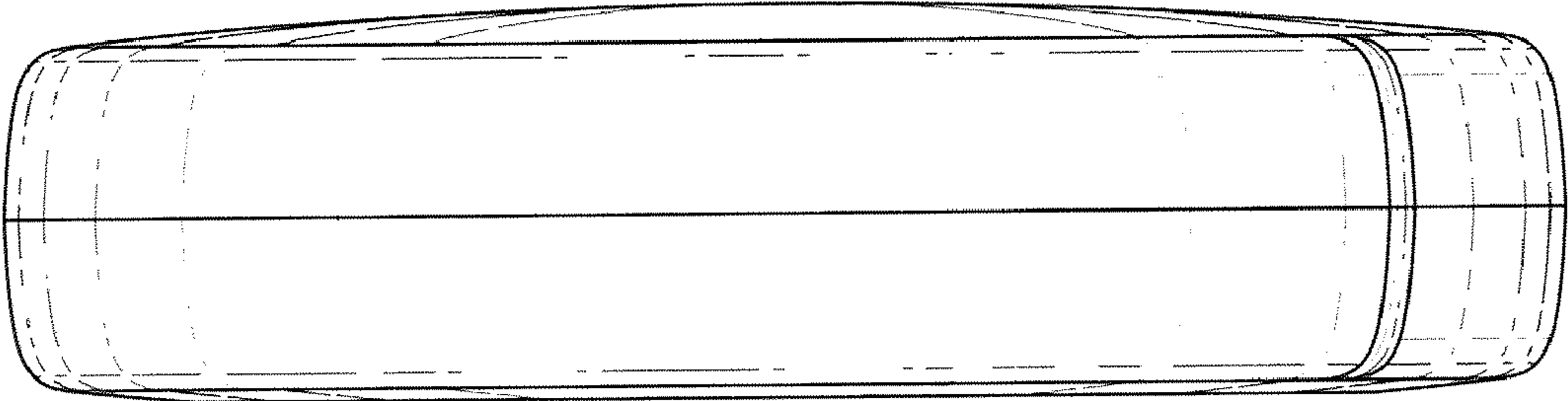

FIG. 3

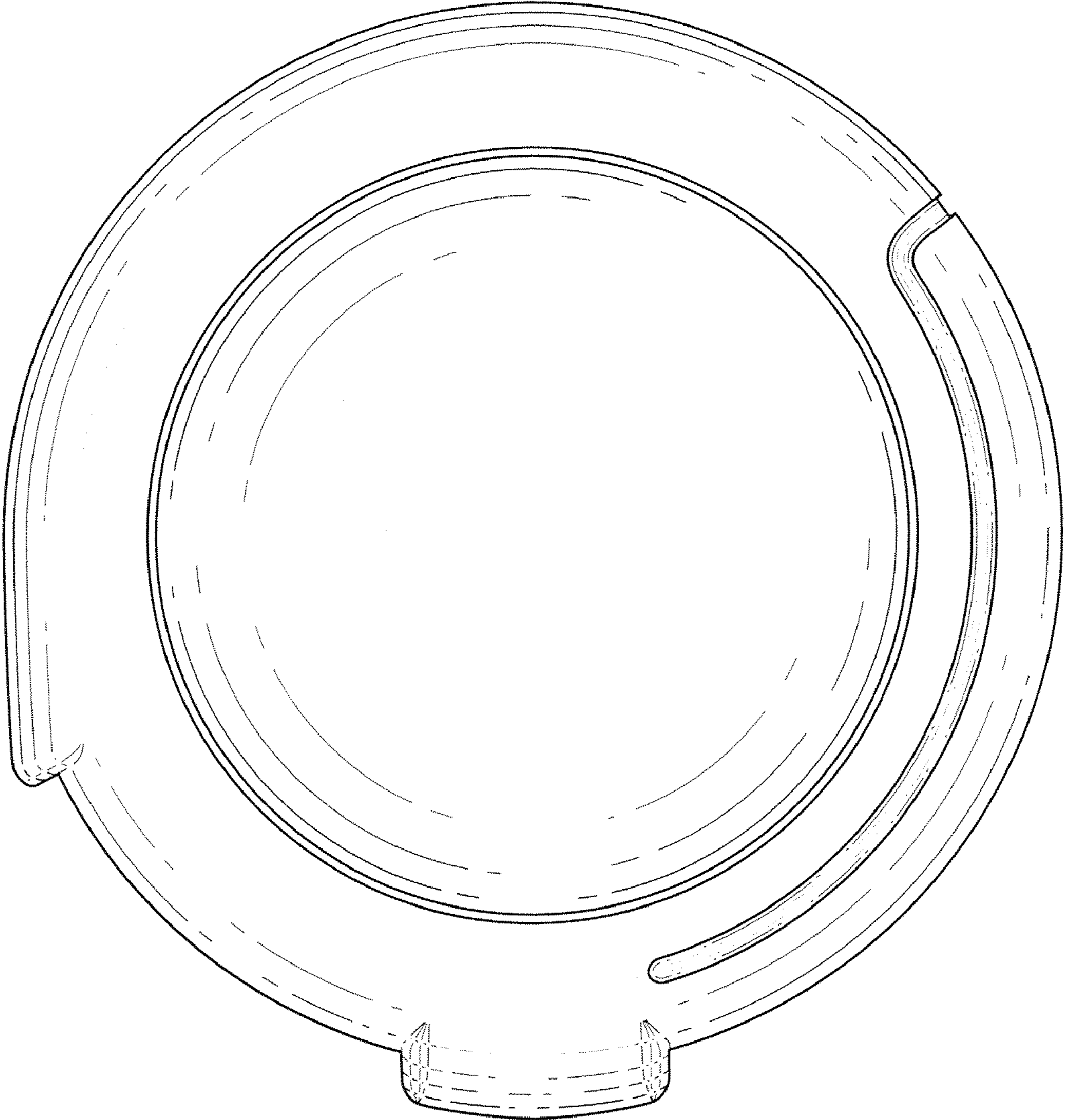

FIG. 2

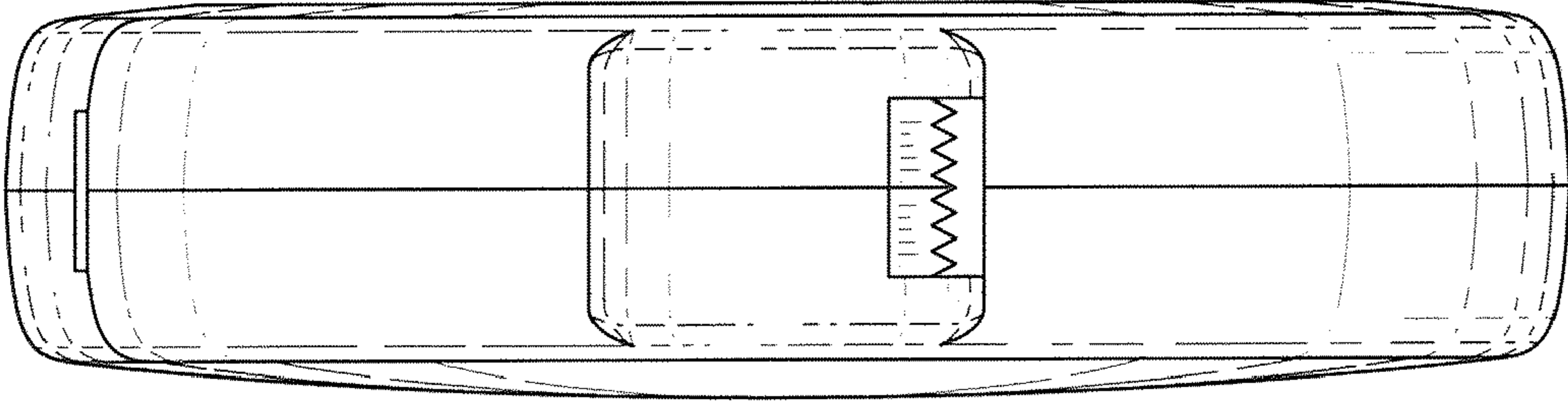

FIG. 5

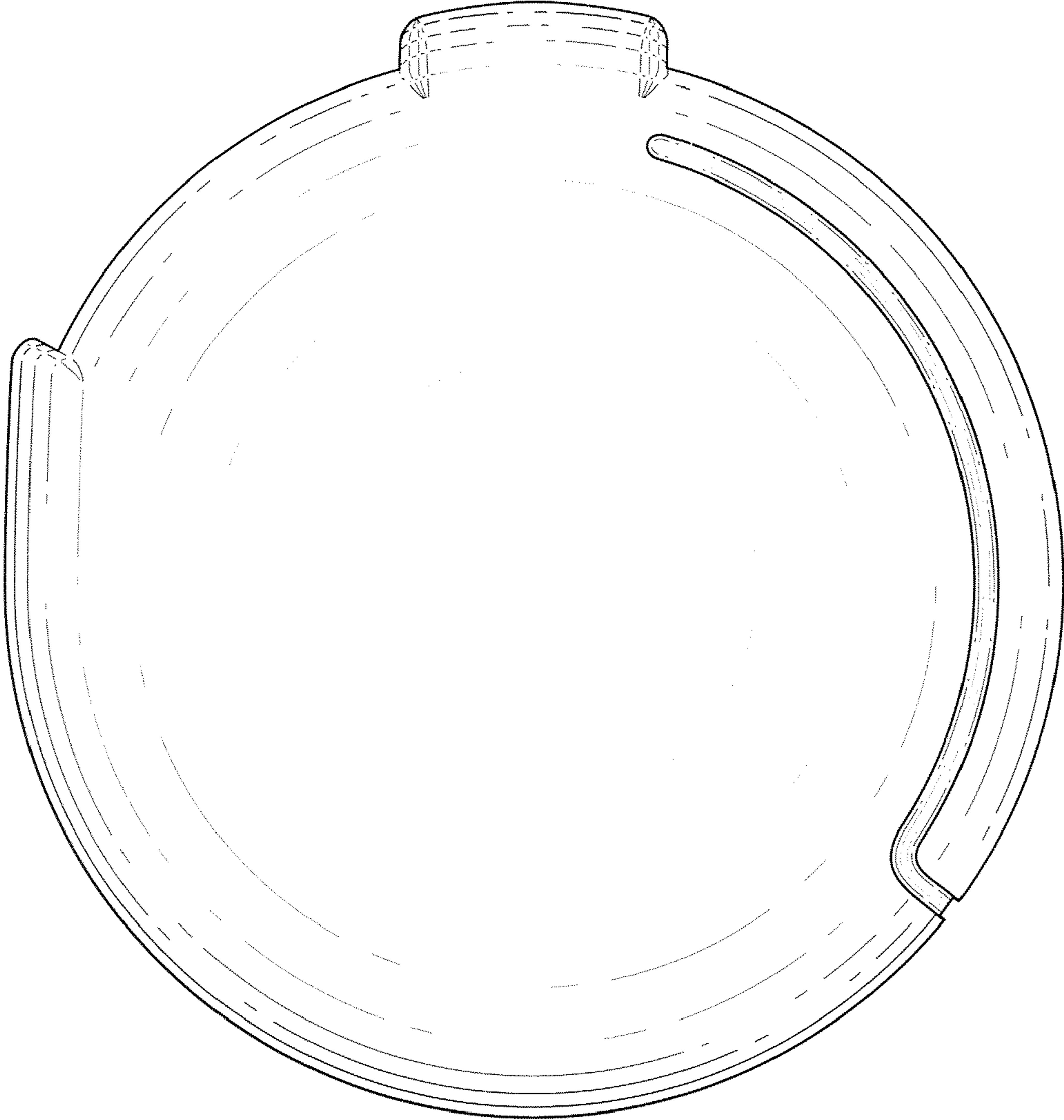

FIG. 4

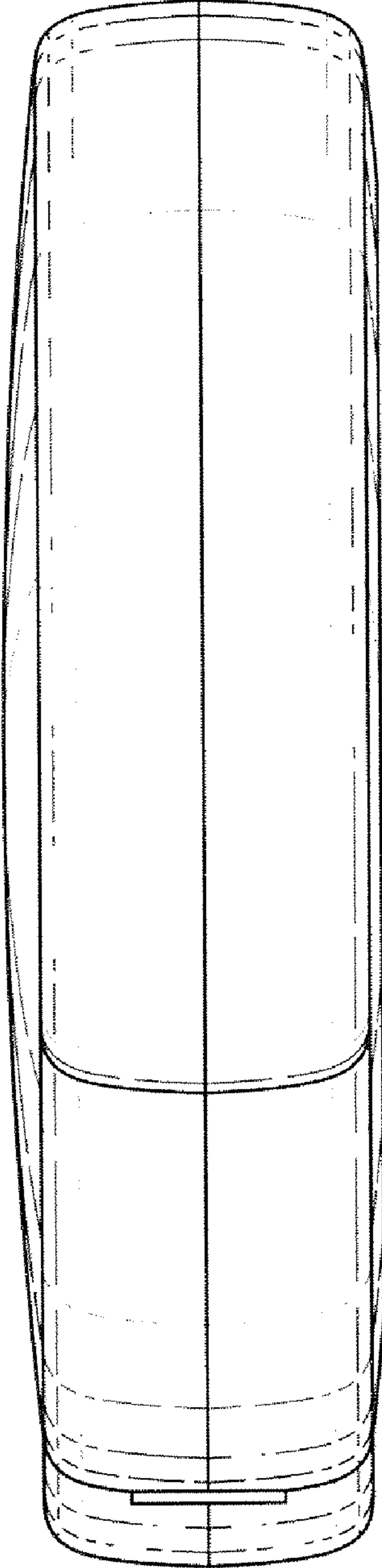

FIG. 6

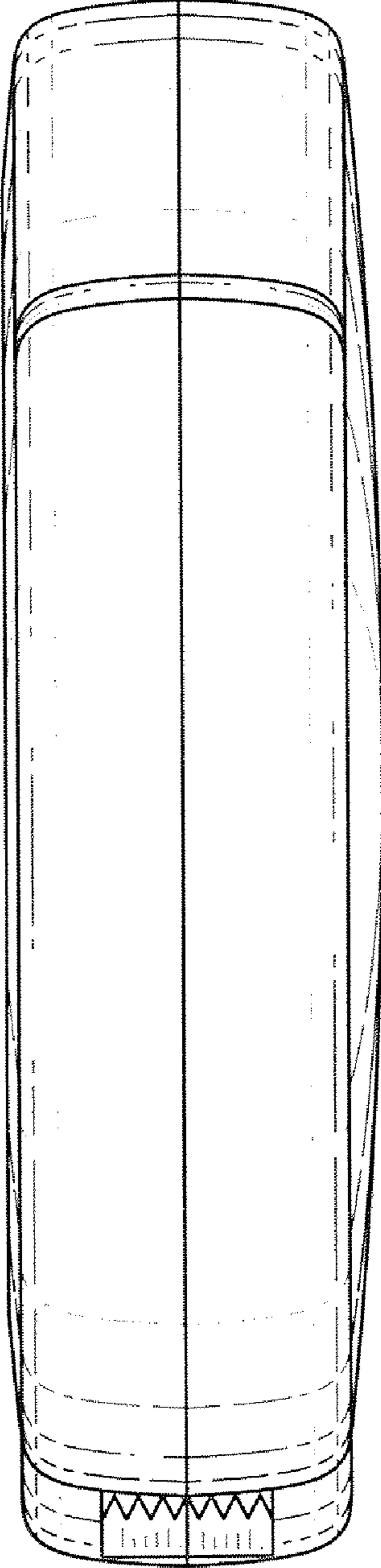

FIG. 7