



US00D616940S

(12) **United States Design Patent**
Gutierrez et al.

(10) **Patent No.:** **US D616,940 S**
(45) **Date of Patent:** **** Jun. 1, 2010**

(54) **TAPE DISPENSER**

(75) Inventors: **Carlos Gutierrez**, Cumberland, RI (US);
Viviana Guerriero, Braintree, MA (US);
Steven Cote, Uxbridge, MA (US)

(73) Assignee: **Tyco Healthcare Group LP**, Mansfield,
MA (US)

(**) Term: **14 Years**

(21) Appl. No.: **29/346,740**

(22) Filed: **Nov. 5, 2009**

(51) **LOC (9) Cl.** **08-02**

(52) **U.S. Cl.** **D19/69**

(58) **Field of Classification Search** D19/36,
D19/70, 69, 68; D13/133, 146; 242/588.6,
242/588.3, 588.2; 225/77, 6, 56, 69, 26,
225/25, 19, 11; 206/411; 156/577, 527,
156/523

See application file for complete search history.

(56) **References Cited**

U.S. PATENT DOCUMENTS

D273,875 S *	5/1984	Hill	D19/69
D308,891 S *	6/1990	Harris	D19/69
D372,050 S *	7/1996	Ho	D19/59
D415,528 S *	10/1999	Mandar	D19/69
D470,181 S *	2/2003	Jour	D19/69

D492,356 S *	6/2004	Milliorn et al.	D19/69
D540,872 S *	4/2007	Goolrick	D19/69

* cited by examiner

Primary Examiner—Cathron C Brooks

Assistant Examiner—Austin Murphy

(74) *Attorney, Agent, or Firm*—Elizabeth A. O'Brien, Esq.

(57) **CLAIM**

The ornamental design for a tape dispenser, as shown and described.

DESCRIPTION

FIG. 1 is a perspective view of a tape dispenser of the present disclosure;

FIG. 2 is a side elevational view of the tape dispenser of FIG. 1;

FIG. 3 is a top plan view of the tape dispenser of FIG. 1;

FIG. 4 is a front elevational view of the tape dispenser of FIG. 1; and

FIG. 5 is a rear elevational view of the tape dispenser of FIG. 1; and,

FIG. 6 is a bottom plan view of the tape dispenser of FIG. 1.

The broken lines shown in the drawings represent unclaimed portions of the tape dispenser and form no part thereof.

1 Claim, 3 Drawing Sheets

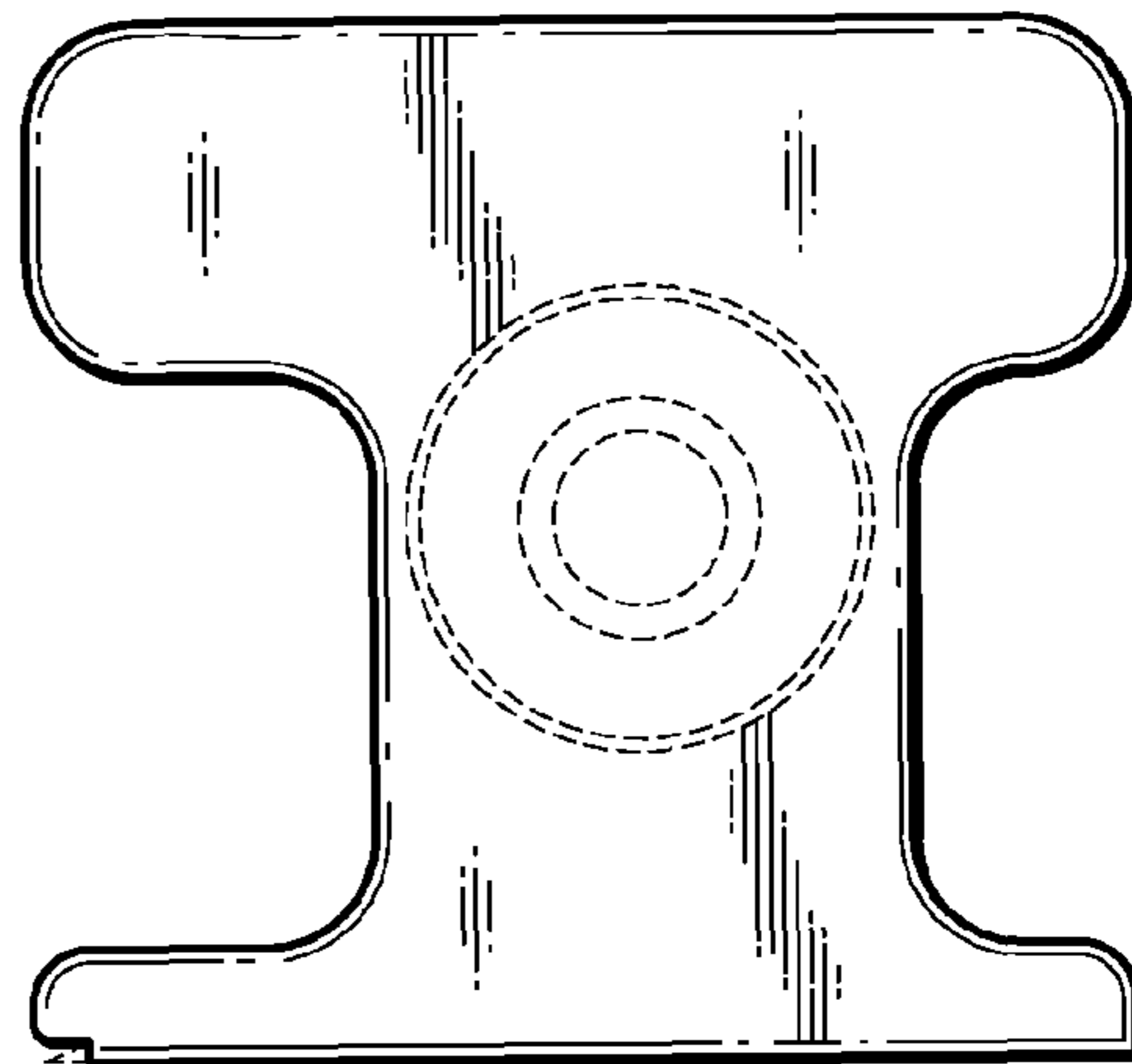
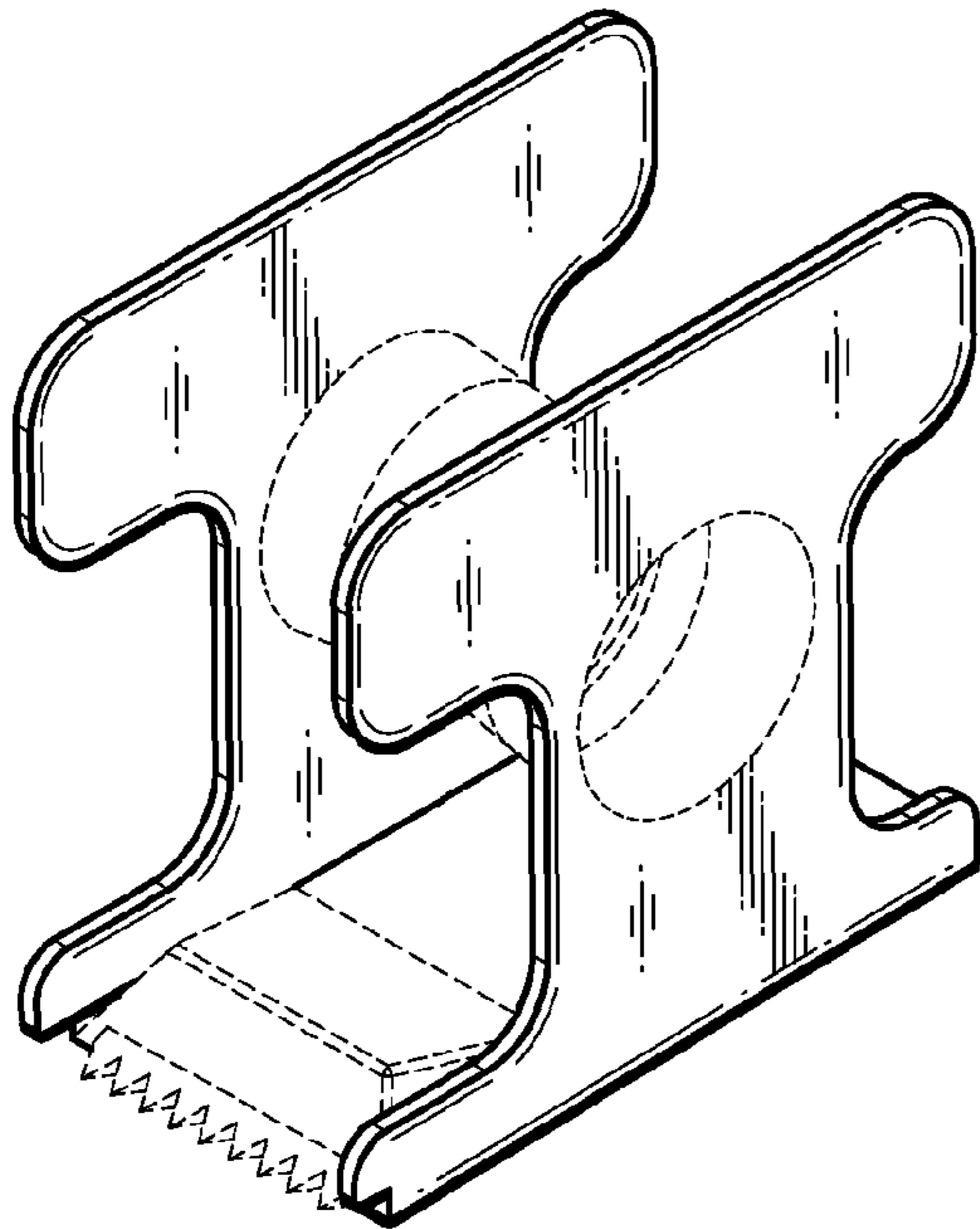

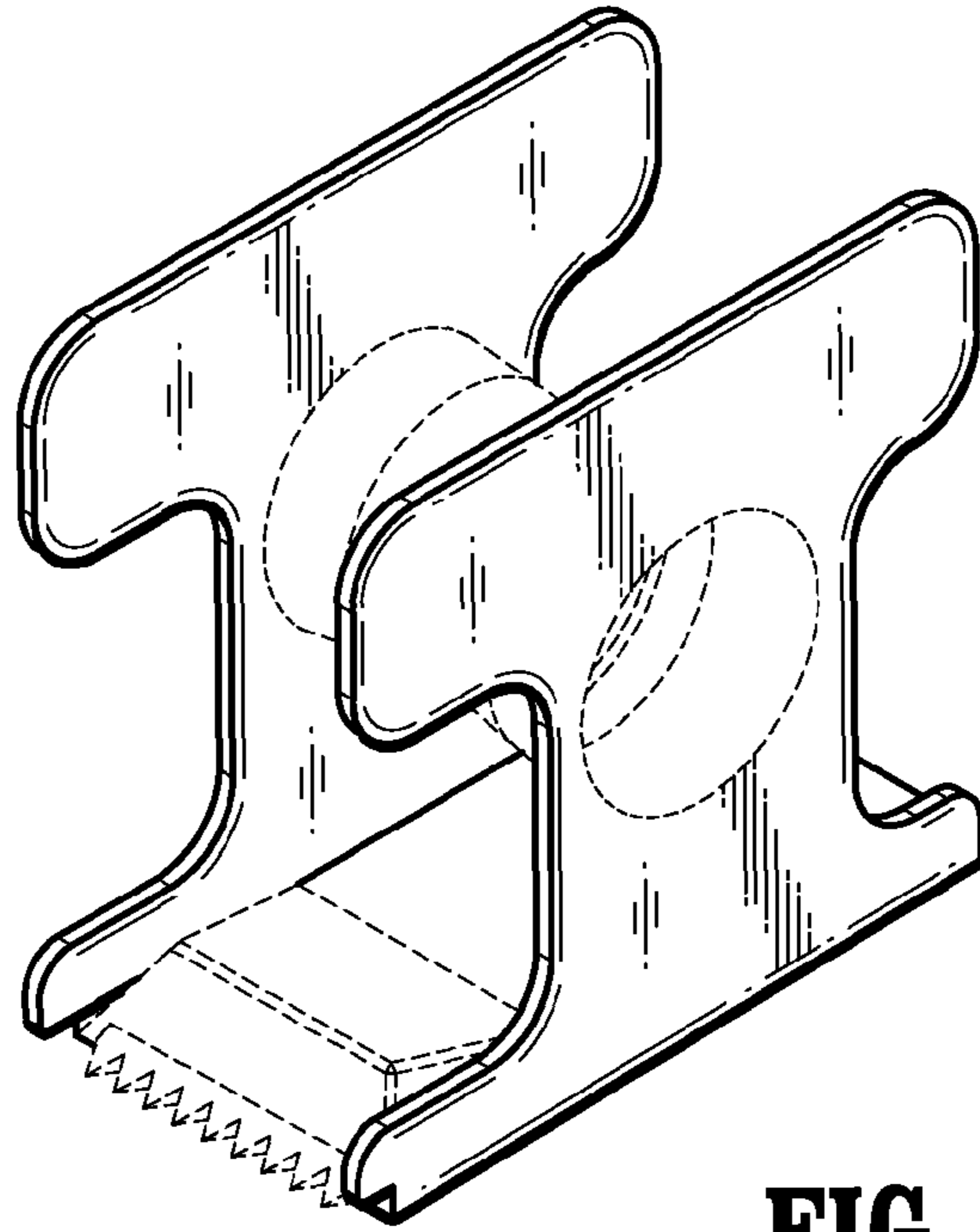

FIG. 1

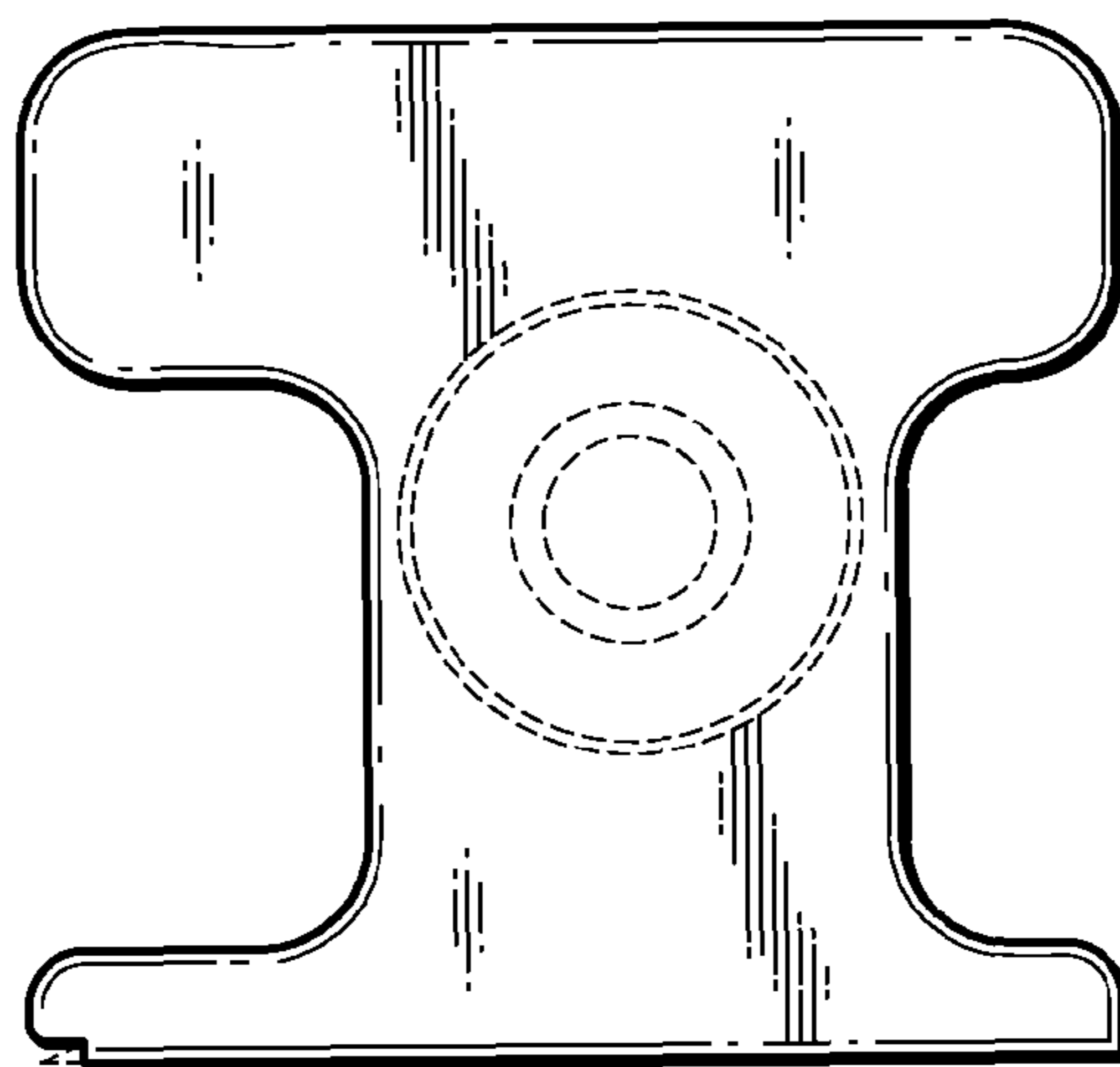

FIG. 2

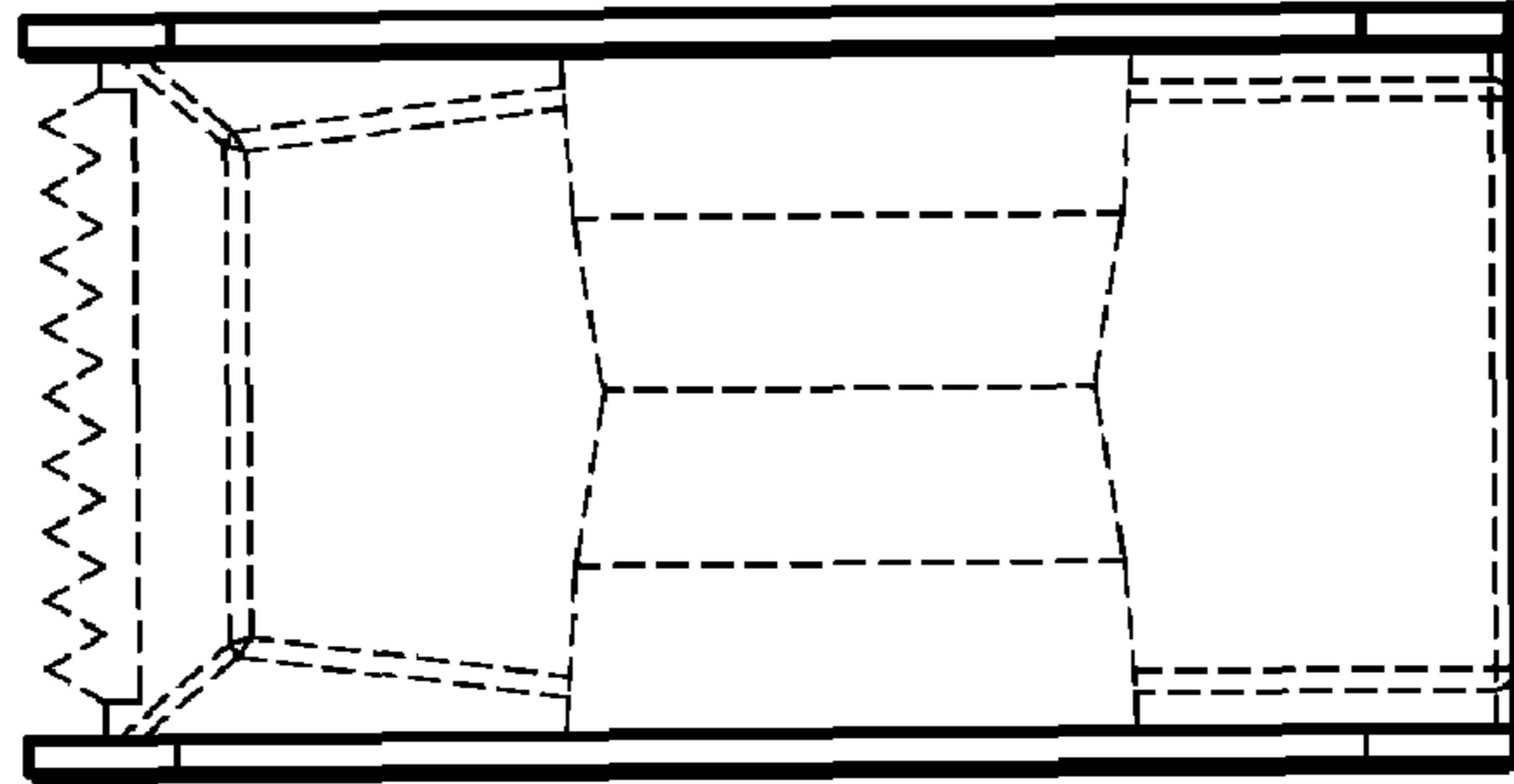

FIG. 3

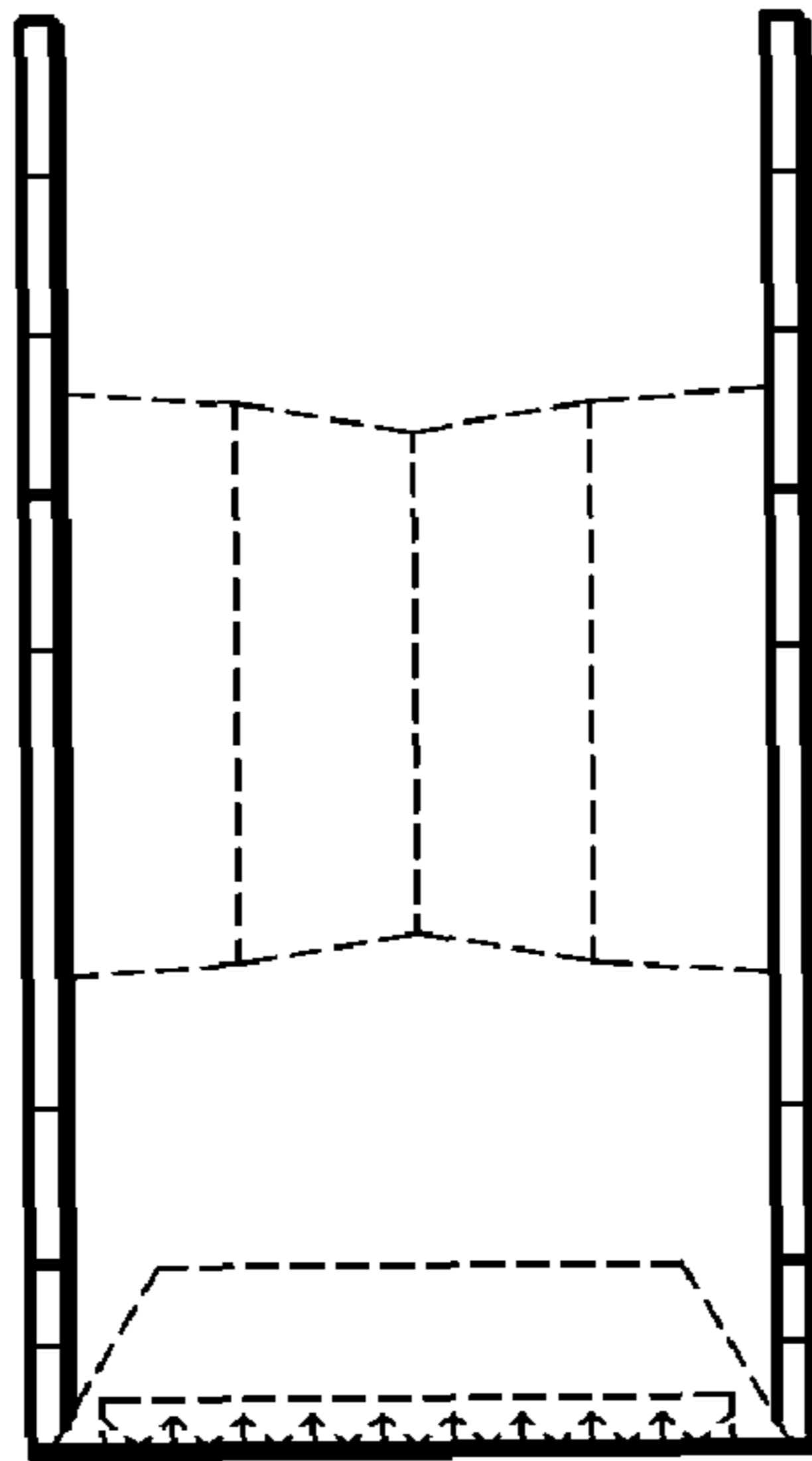

FIG. 4

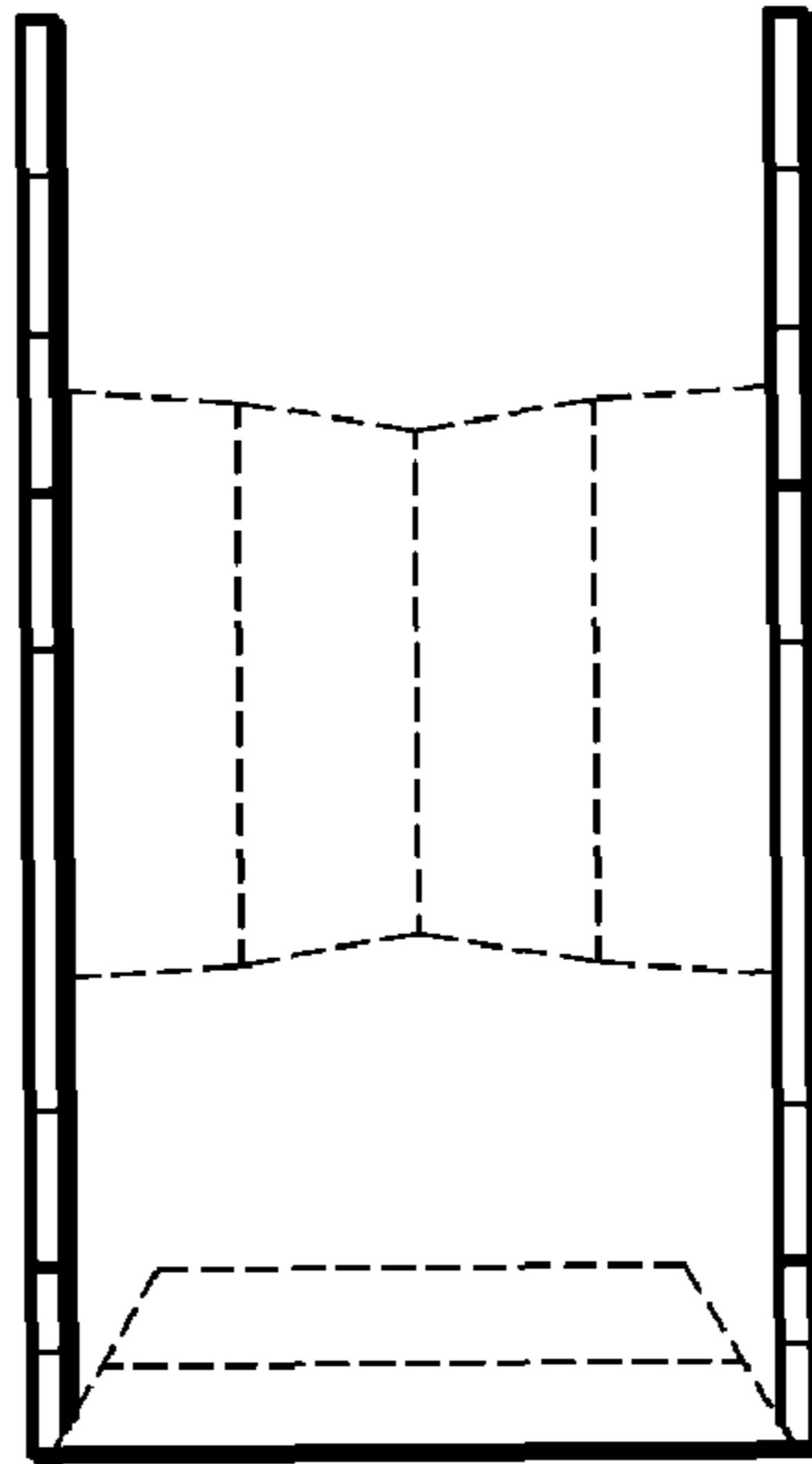

FIG. 5

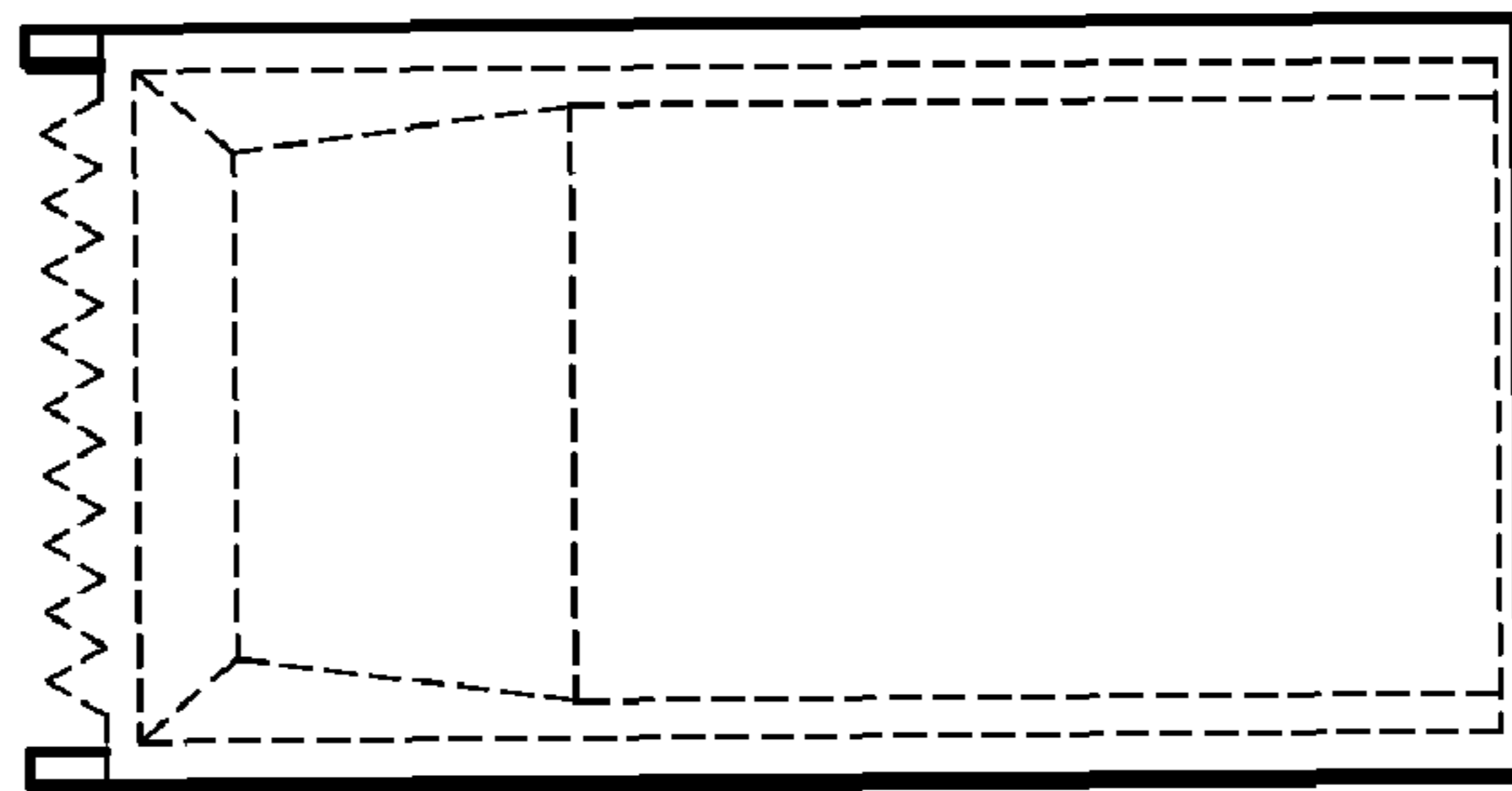

FIG. 6