



US00D616810S

(12) **United States Design Patent**
Scheuren et al.

(10) **Patent No.:** **US D616,810 S**
(45) **Date of Patent:** **** Jun. 1, 2010**

(54) **TIRE**

D593,938 S * 6/2009 Lee D12/588
D601,950 S * 10/2009 Pressley et al. D12/588
D603,788 S * 11/2009 Lundgren D12/602

(75) Inventors: **Daniel Scheuren**, Arlon (BE); **Herve Marcel Henri Beauguitte**, Colmar-Berg (LU); **Agnes Nathalie Iwana Ensich**, Arlon (BE)

* cited by examiner

Primary Examiner—Caron Veynar
Assistant Examiner—Katrina A Kile

(73) Assignee: **The Goodyear Tire & Rubber Company**, Akron, OH (US)

(74) *Attorney, Agent, or Firm*—Richard B. O’Planick

(**) Term: **14 Years**

(57) **CLAIM**

(21) Appl. No.: **29/325,809**

The ornamental design for a tire, as shown and described.

(22) Filed: **Oct. 7, 2008**

DESCRIPTION

(51) **LOC (9) Cl.** **12-15**

FIG. 1 is a perspective view of a tire showing our new design, it being understood that the pattern repeats uniformly throughout the circumference of the tread;

(52) **U.S. Cl.** **D12/601**

FIG. 2 is a front elevational view thereof;

(58) **Field of Classification Search** D12/503,
D12/505, 533, 534, 535, 536, 537, 543, 547,
D12/548, 549, 550, 564, 565, 566, 567, 568,
D12/569–572, 579, 583–588, 594, 595, 596,
D12/597, 598, 599, 600–604; 152/209.1,
152/209.8, 209.9, 209.18, 209.25, 209.28

FIG. 3 is a right side elevational view thereof; the opposite side elevational view being identical thereto;

See application file for complete search history.

FIG. 4 is an enlarged fragmentary front elevational view thereof;

(56) **References Cited**

FIG. 5 is a perspective view of a second embodiment of a tire showing our new design, it being understood that the pattern repeats uniformly throughout the circumference of the tread and that the opposite side perspective view is identical thereto; and,

U.S. PATENT DOCUMENTS

D405,737 S	2/1999	de Barsy	D12/147
D412,305 S	7/1999	Harden, Jr. et al.	D12/147
D453,730 S	2/2002	Weber	D12/532
D478,862 S	8/2003	Gillard et al.	D12/602
D480,351 S	10/2003	Dixon et al.	D12/601
D517,001 S	3/2006	Maziarka et al.	D12/597
D541,731 S	5/2007	Maziarka et al.	D12/528
D554,050 S *	10/2007	Whitney et al.	D12/537
D554,055 S *	10/2007	Beauguitte et al.	D12/600
D563,864 S *	3/2008	Ochi	D12/601
D584,221 S *	1/2009	Himuro	D12/584
D591,223 S *	4/2009	Missik-Gaffney et al.	..	D12/584

FIG. 6 is a front elevational view of a second embodiment, it being understood that an enlarged fragmentary view thereof would be substantially identical to that shown in FIG. 4, with the exception of the inclusion of the sidewall in solid lines.

In the drawings, the broken line showing of the sidewall, inner bead and the peripheral boundary between the tire tread and the sidewall in FIGS. 1 through 4 depict environmental subject matter and form no part of the claimed design.

1 Claim, 6 Drawing Sheets

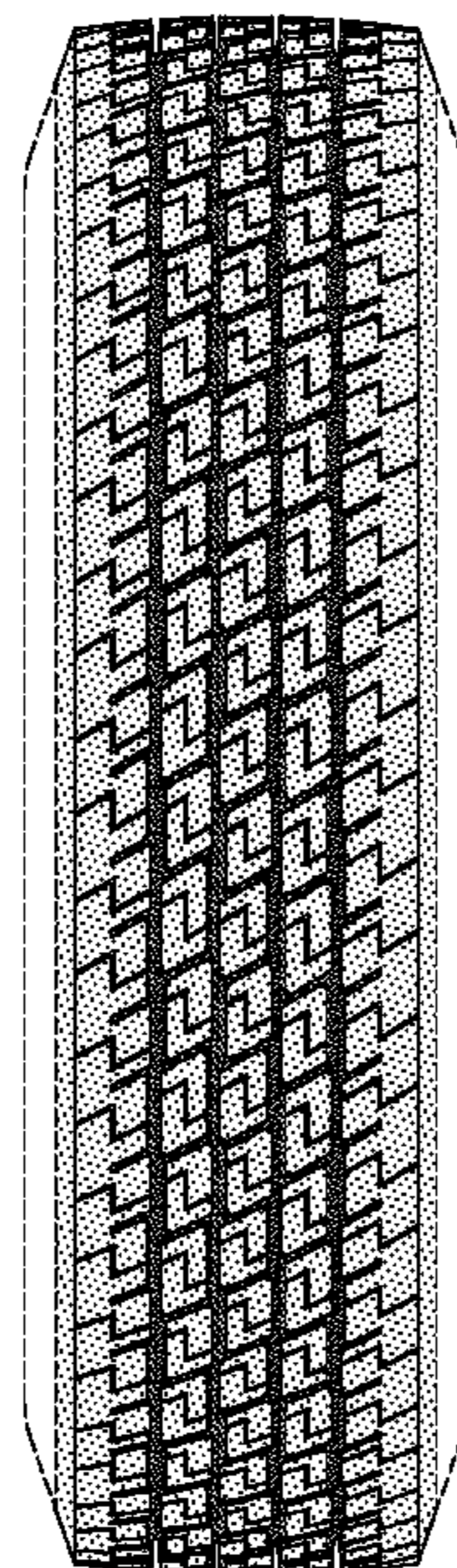

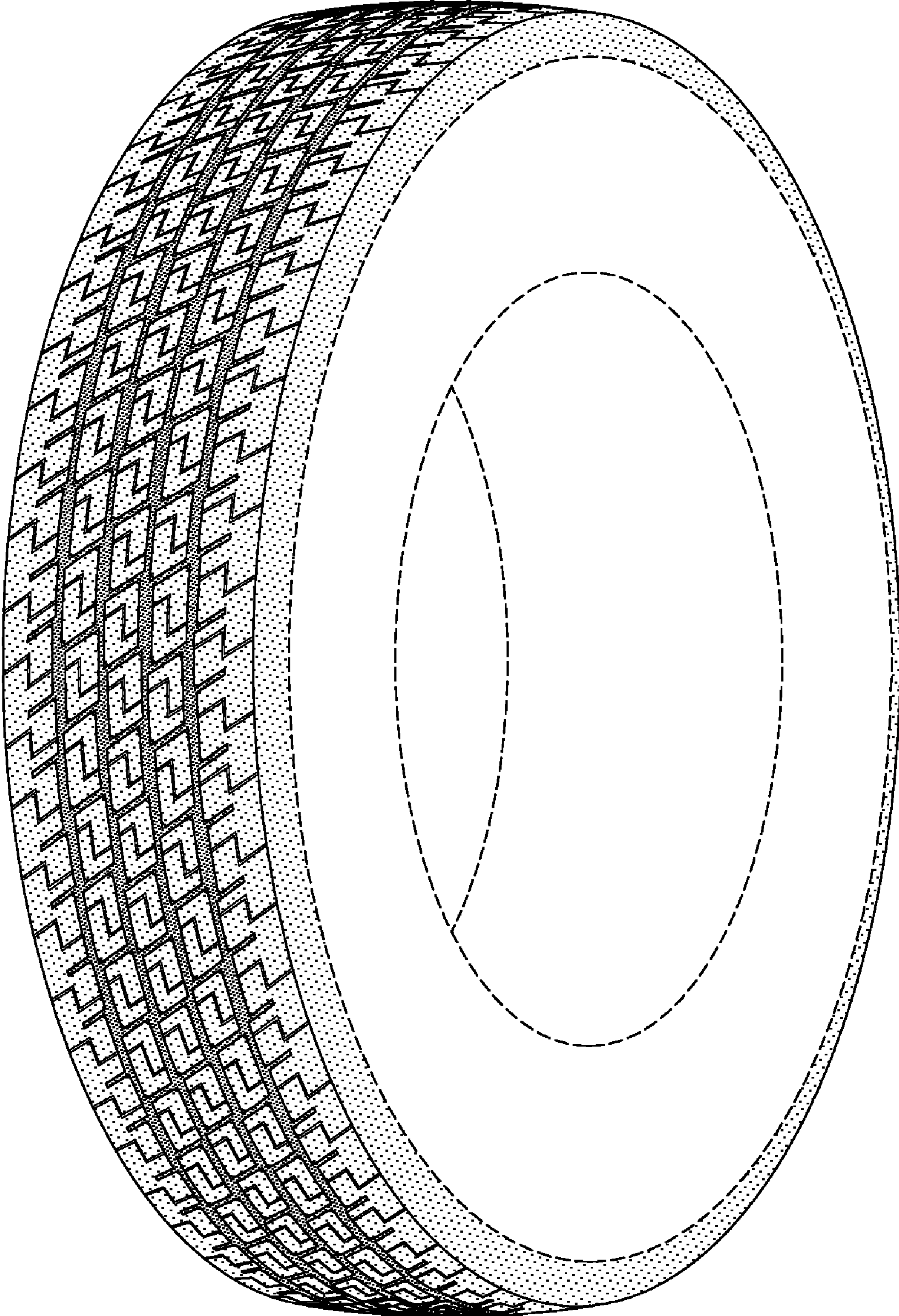

FIG-1

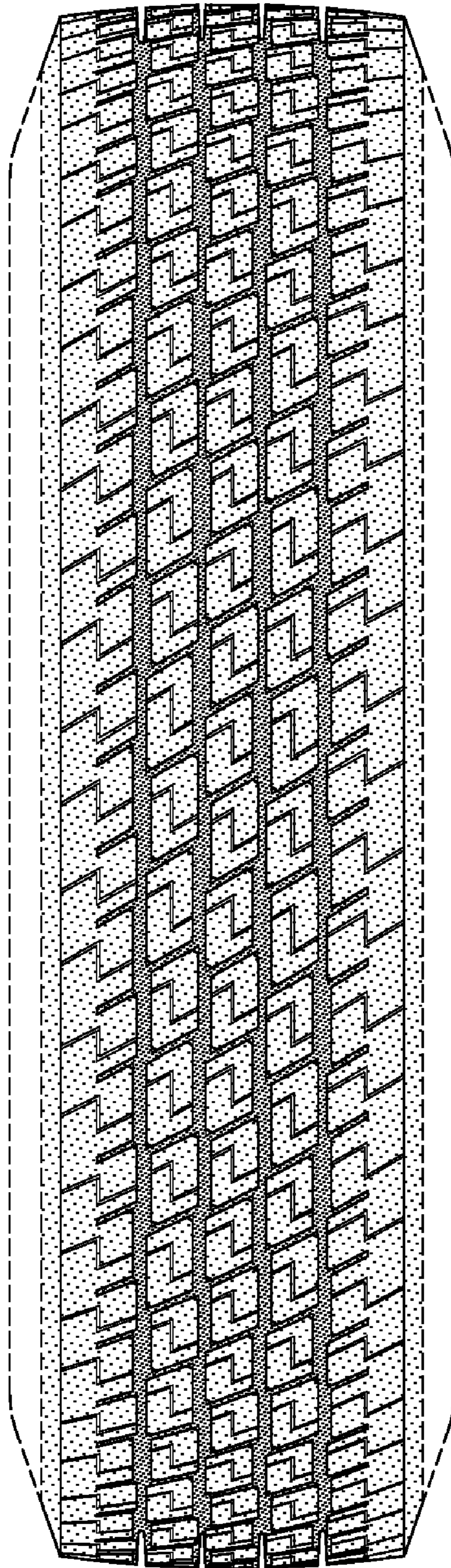

FIG-2

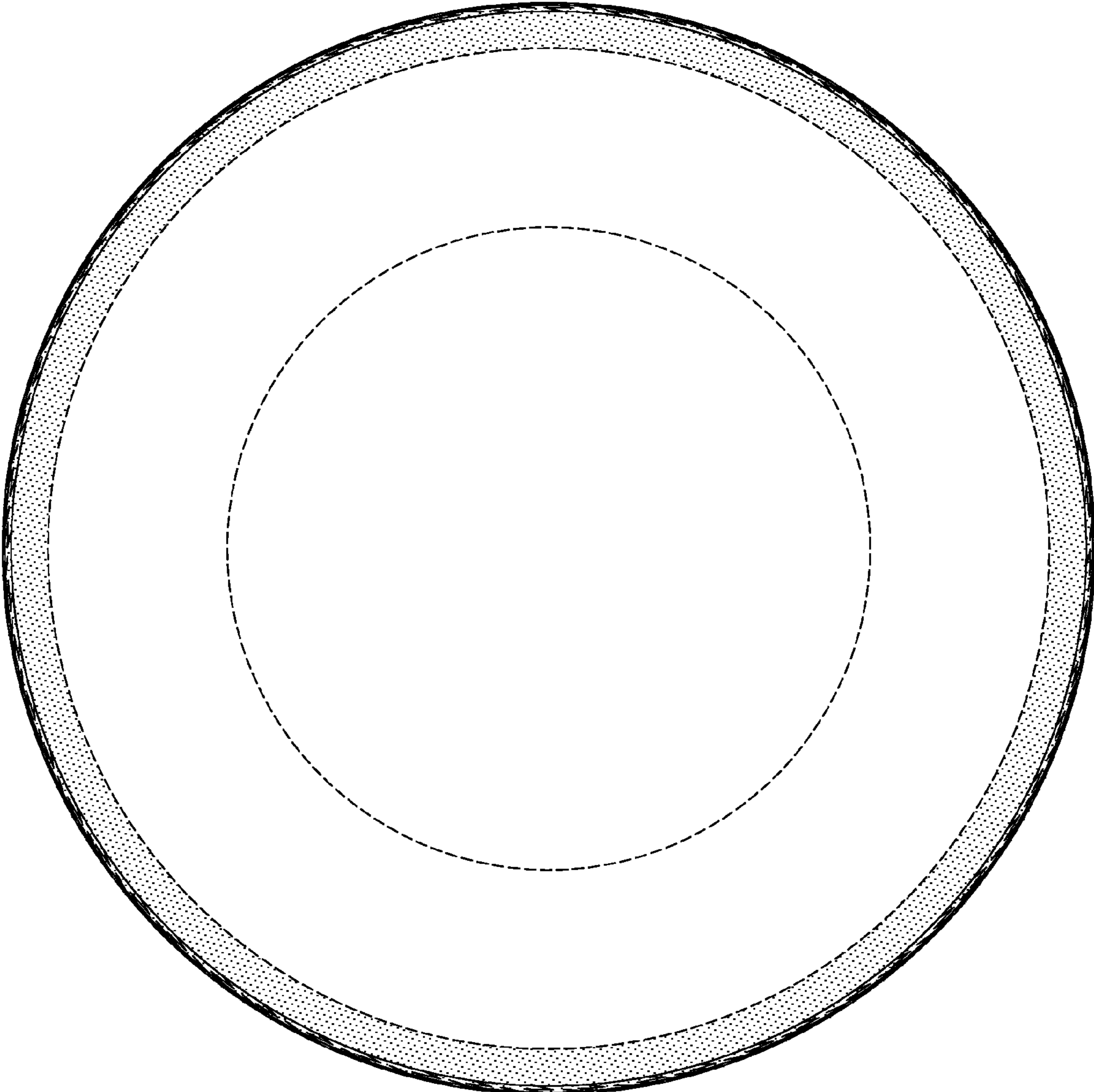

FIG-3

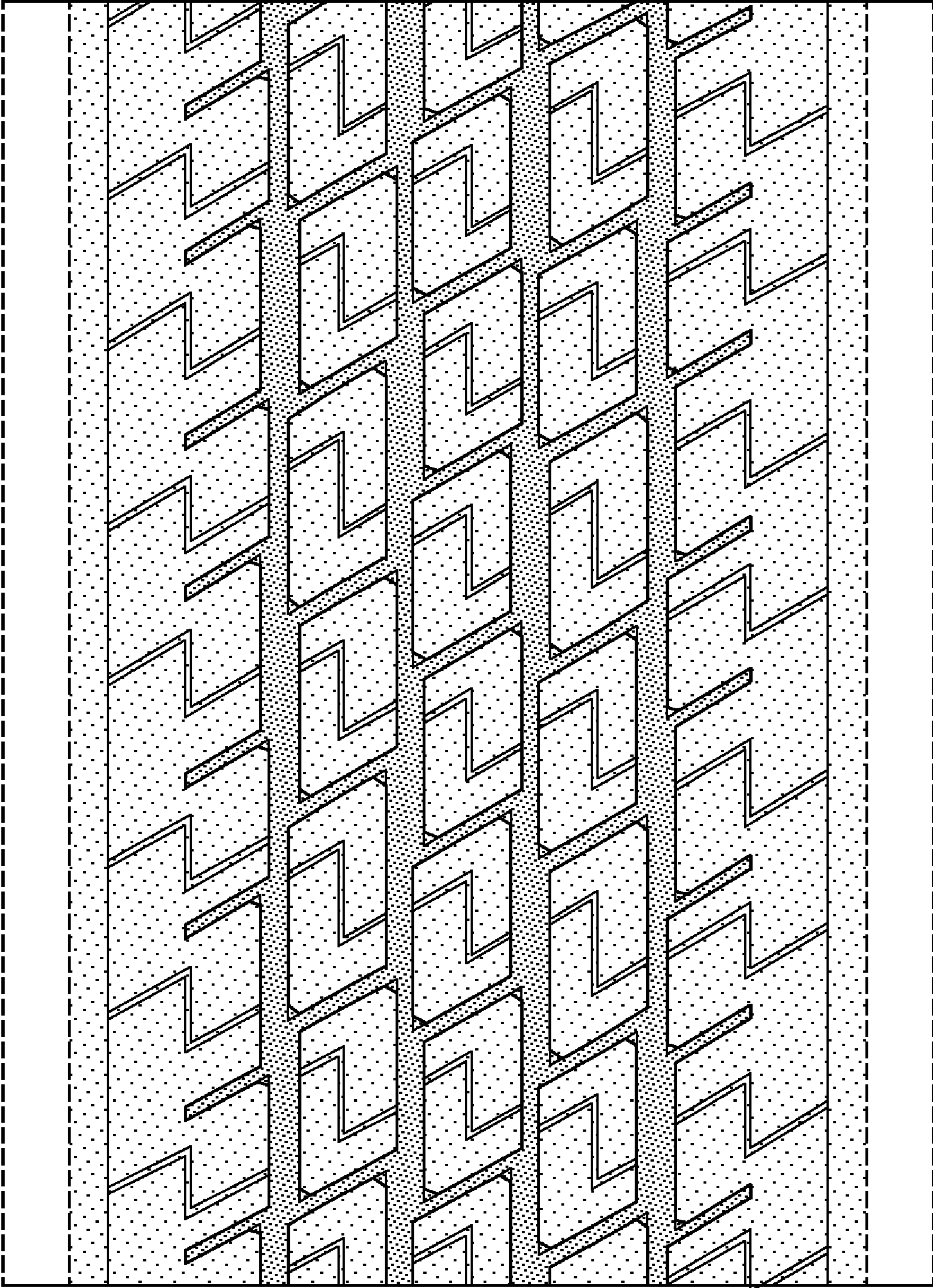

FIG-4

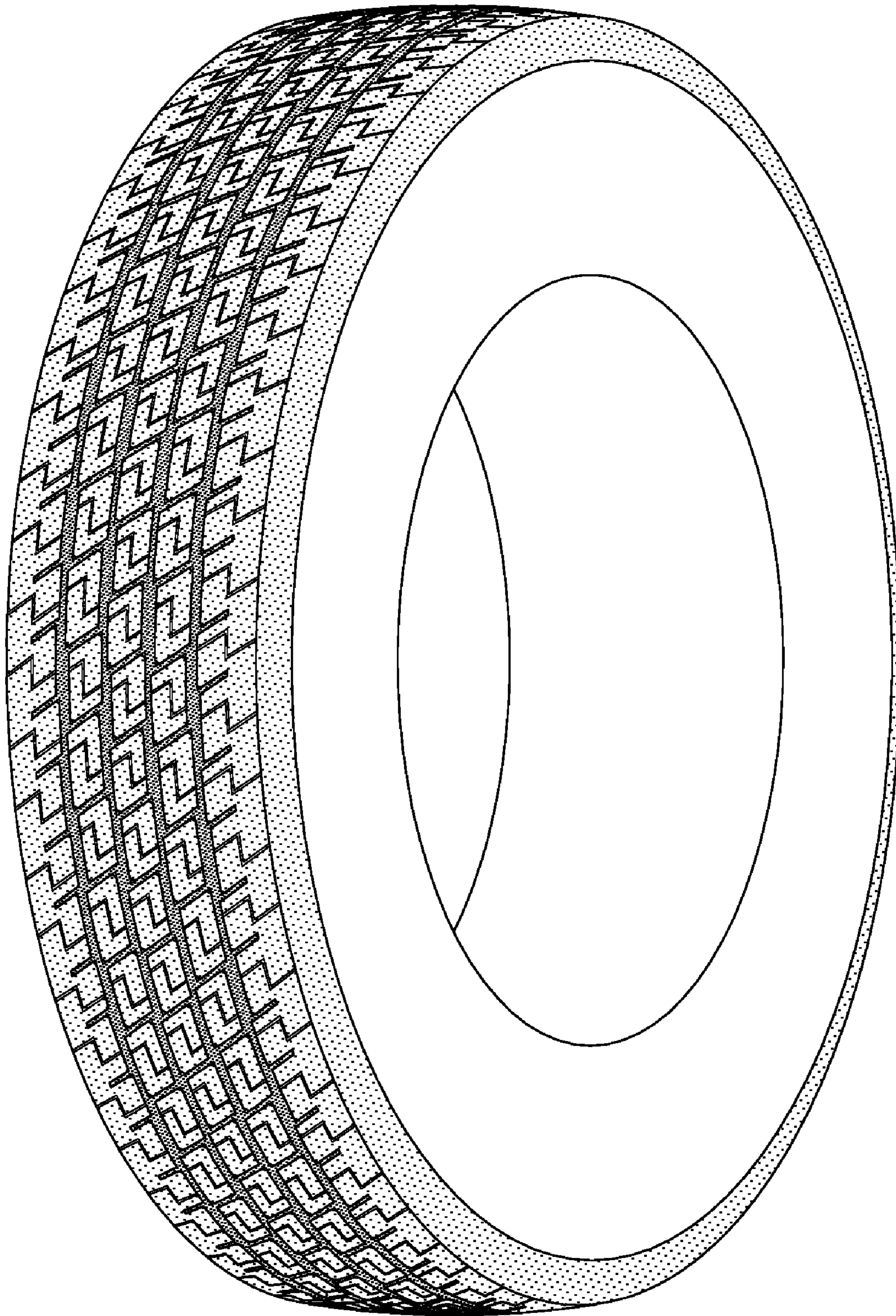

FIG-5

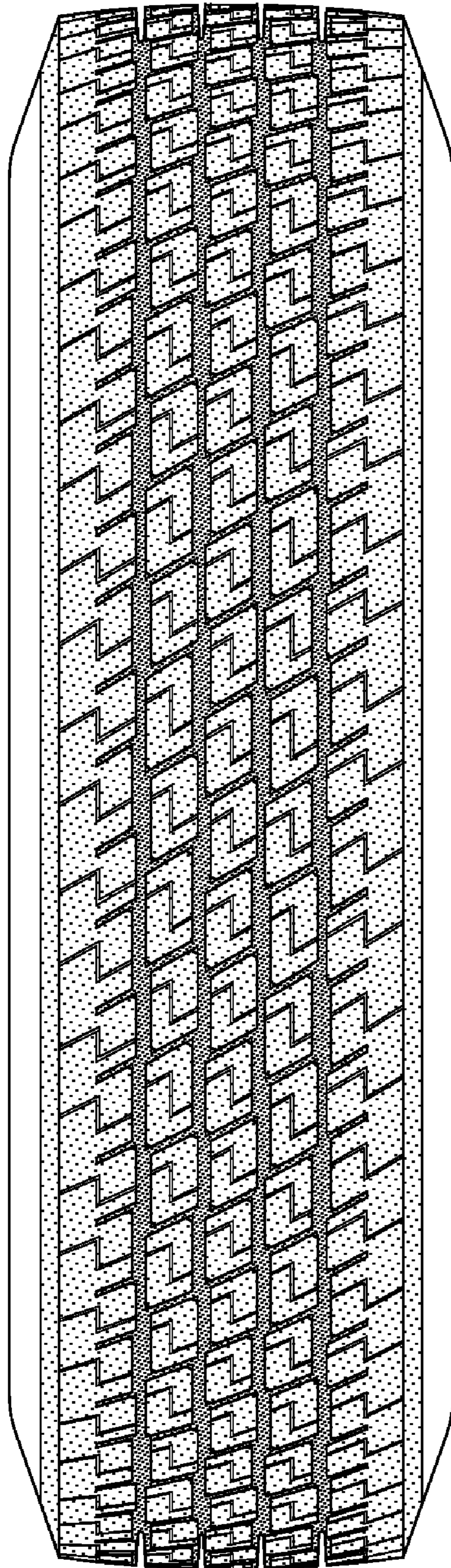

FIG-6