



US00D616697S

(12) **United States Design Patent**
Muller

(10) **Patent No.:** **US D616,697 S**
(45) **Date of Patent:** **** Jun. 1, 2010**

(54) **ELECTRIC NUT WARMER**

(75) Inventor: **Daniel V. Muller**, Hillsborough, NJ (US)

(73) Assignee: **Jackel International, Inc.**,
Hillsborough, NJ (US)

(**) Term: **14 Years**

(21) Appl. No.: **29/315,461**

(22) Filed: **Jun. 26, 2009**

(51) **LOC (9) Cl.** **07-02**

(52) **U.S. Cl.** **D7/354**

(58) **Field of Classification Search** D7/323,
D7/330-331, 339, 36, 350-367, 378-379,
D7/383-384, 391, 542-545; 99/324-325,
99/329 R, 330-339; 219/432-433, 438-441,
219/620-622, 725-730; 220/203.1, 203.7,
220/303, 573.1-574, 769, 912; 426/438,
426/441

See application file for complete search history.

(56) **References Cited**

U.S. PATENT DOCUMENTS

D91,075 S *	11/1933	Miller	D7/542
D96,141 S *	7/1935	Smith	D7/542
D241,601 S *	9/1976	Cook	D7/356
D276,493 S *	11/1984	Cesaroni	D7/355
D438,422 S *	3/2001	Choi	D7/360
D479,432 S *	9/2003	Barker	D7/360
D525,077 S *	7/2006	White et al.	D7/355
D592,902 S *	5/2009	Currie	D7/355

* cited by examiner

Primary Examiner—Caron Veynar

Assistant Examiner—Ricky Pham

(74) *Attorney, Agent, or Firm*—Horst M. Kasper

(57) **CLAIM**

The ornamental design for the electric nut warmer, as shown and described.

DESCRIPTION

FIG. 1 is a front elevational view of the entire electric nut warmer showing my new design;

FIG. 2 is a top perspective view of a lower portion, shown without the top portion for ease of illustration;

FIG. 3 is a bottom plan view of the lower portion thereof;

FIG. 4 is a top perspective view of an upper portion, shown without the top cover and bottom portion for ease of illustration;

FIG. 5 is a front perspective view of a cover of the upper portion, shown separately for ease of illustration;

FIG. 6 is a top plan view thereof;

FIG. 7 is a top perspective view of the entire design thereof;

FIG. 8 is a top plan view of the lower portion, shown without the top cover and the upper portion for ease of illustration;

FIG. 9 is a front elevational view of the top cover thereof; and,

FIG. 10 is a top plan view of the upper portion, shown without the top cover and bottom portion for ease of illustration.

1 Claim, 10 Drawing Sheets

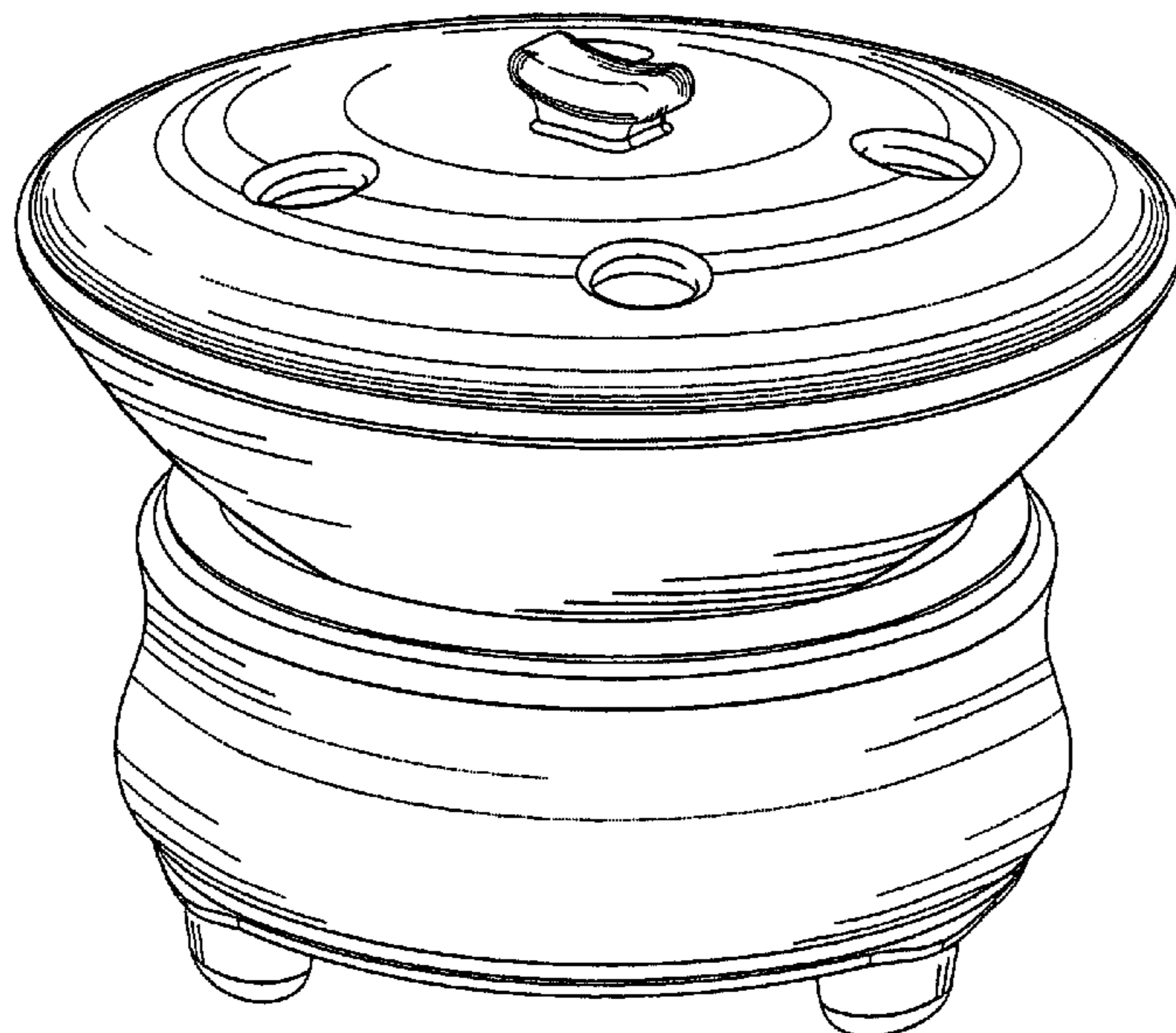

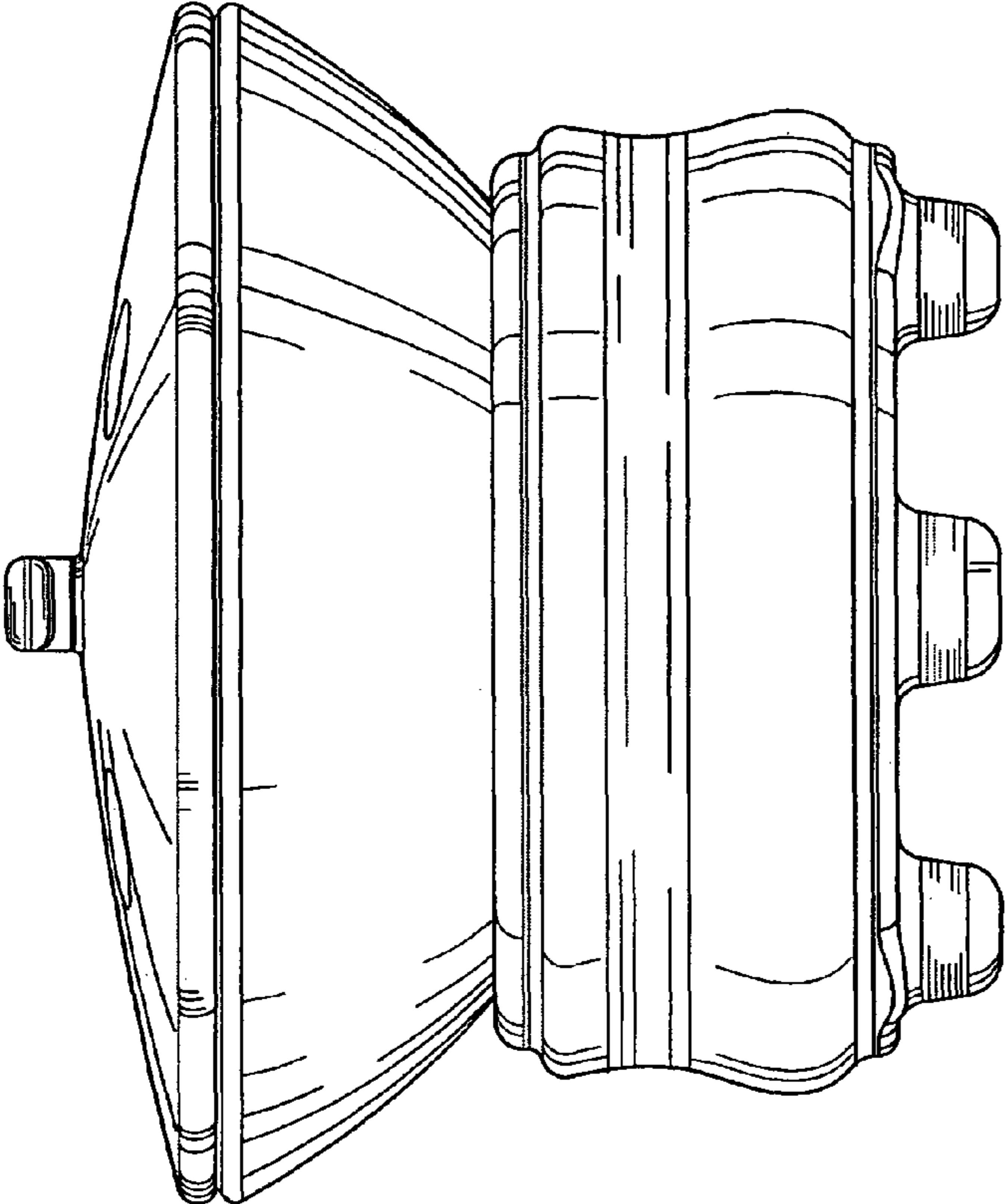

Fig. 1

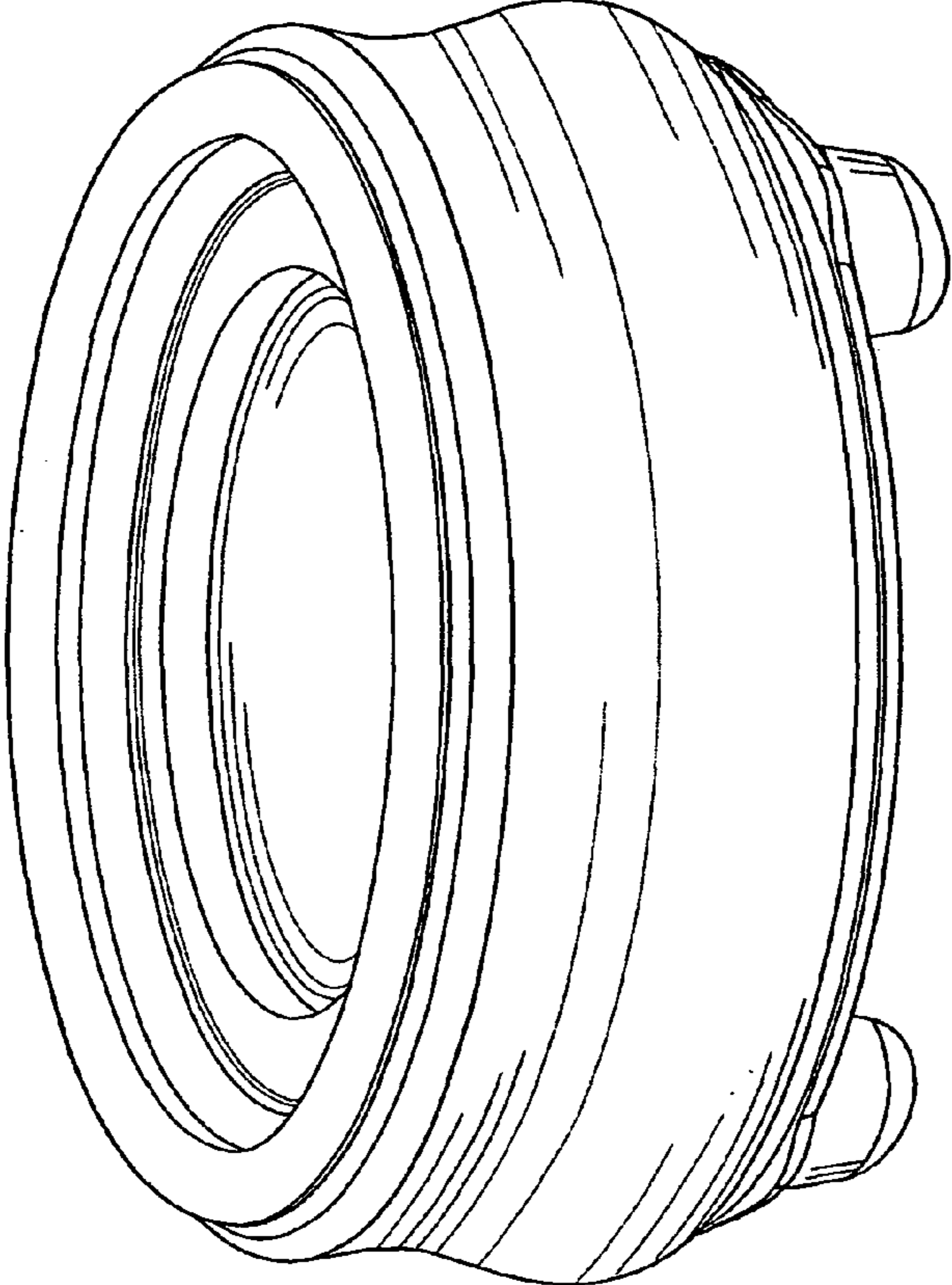

Fig. 2

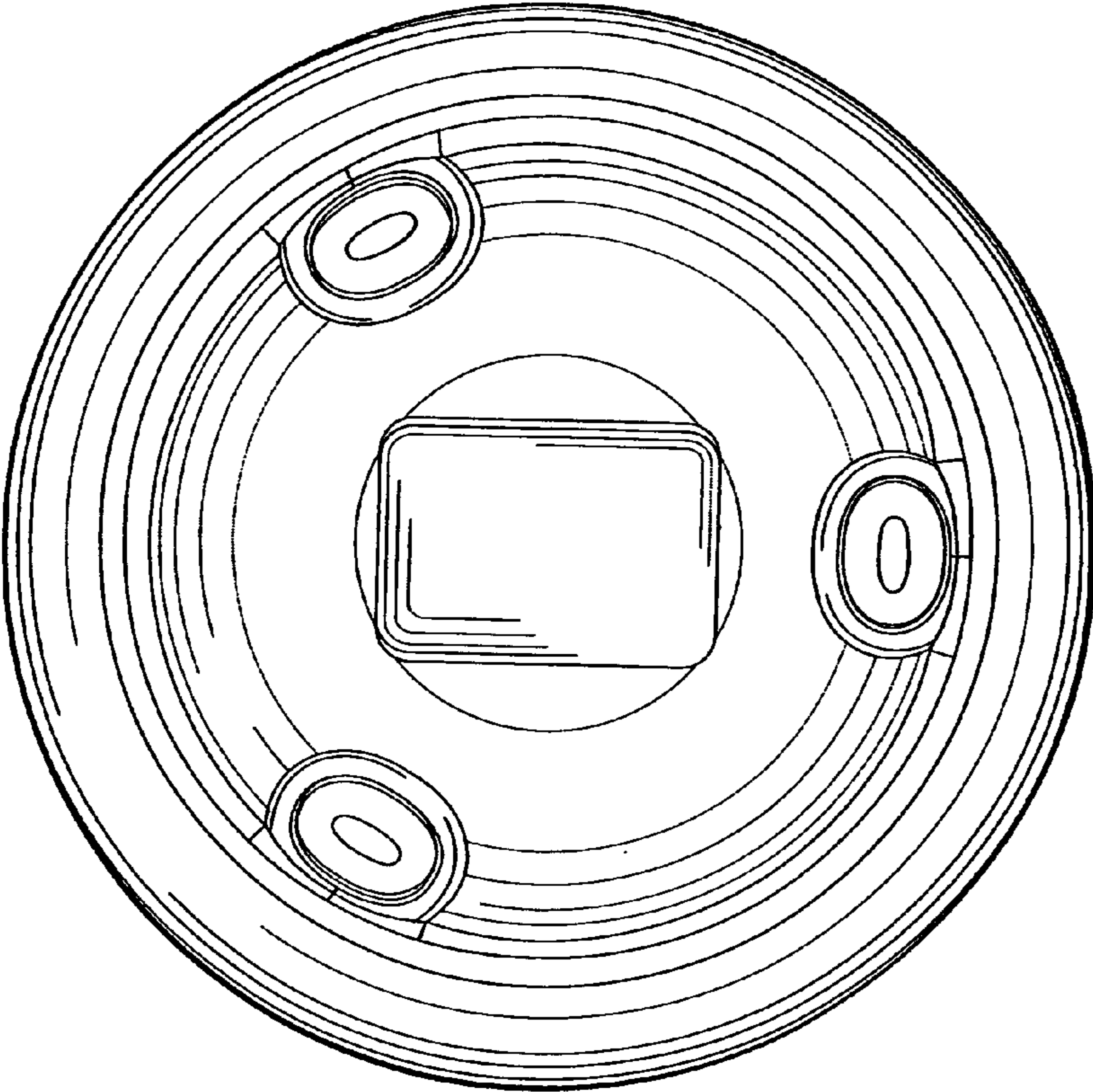

Fig.3

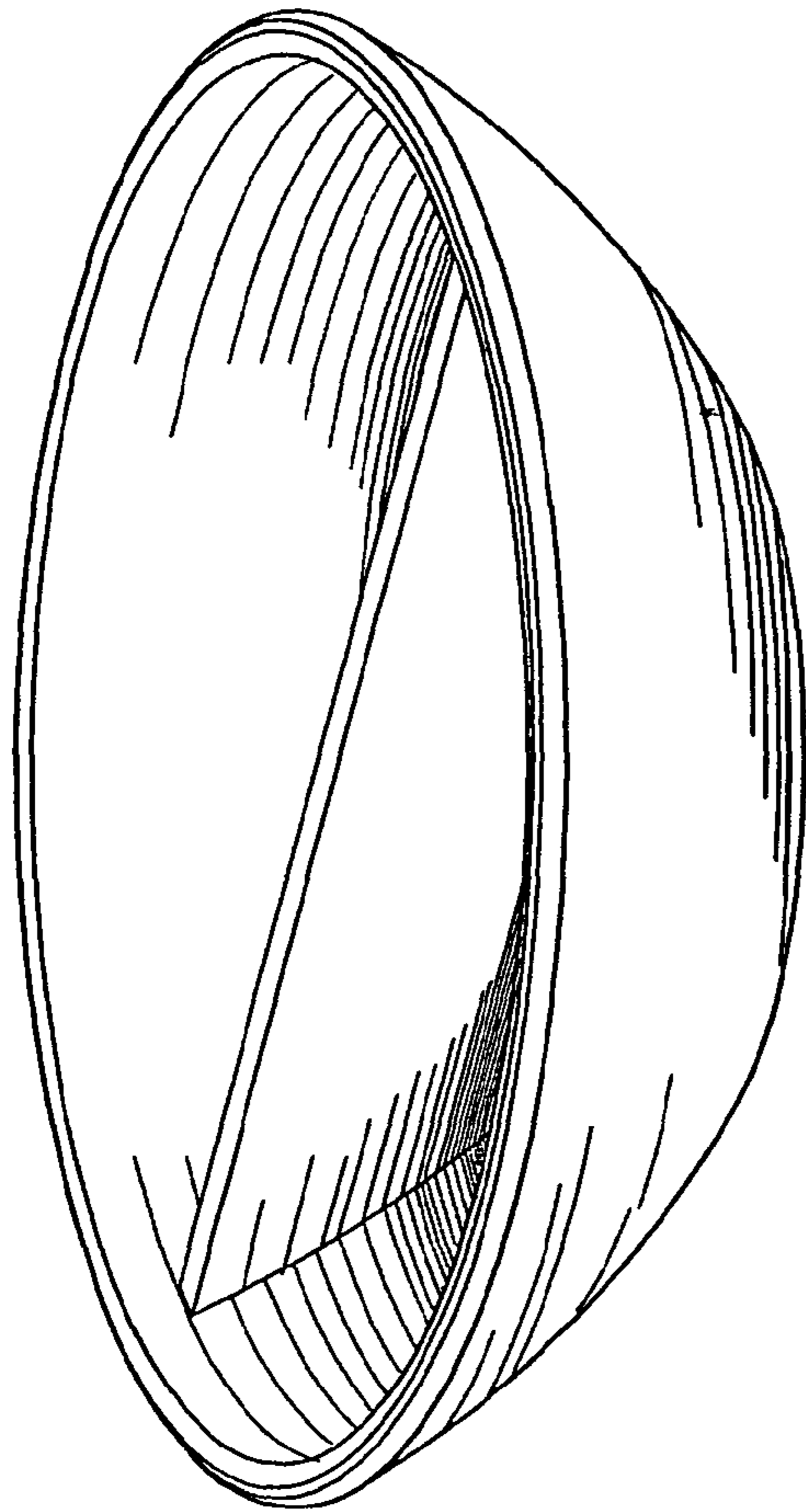

Fig. 4

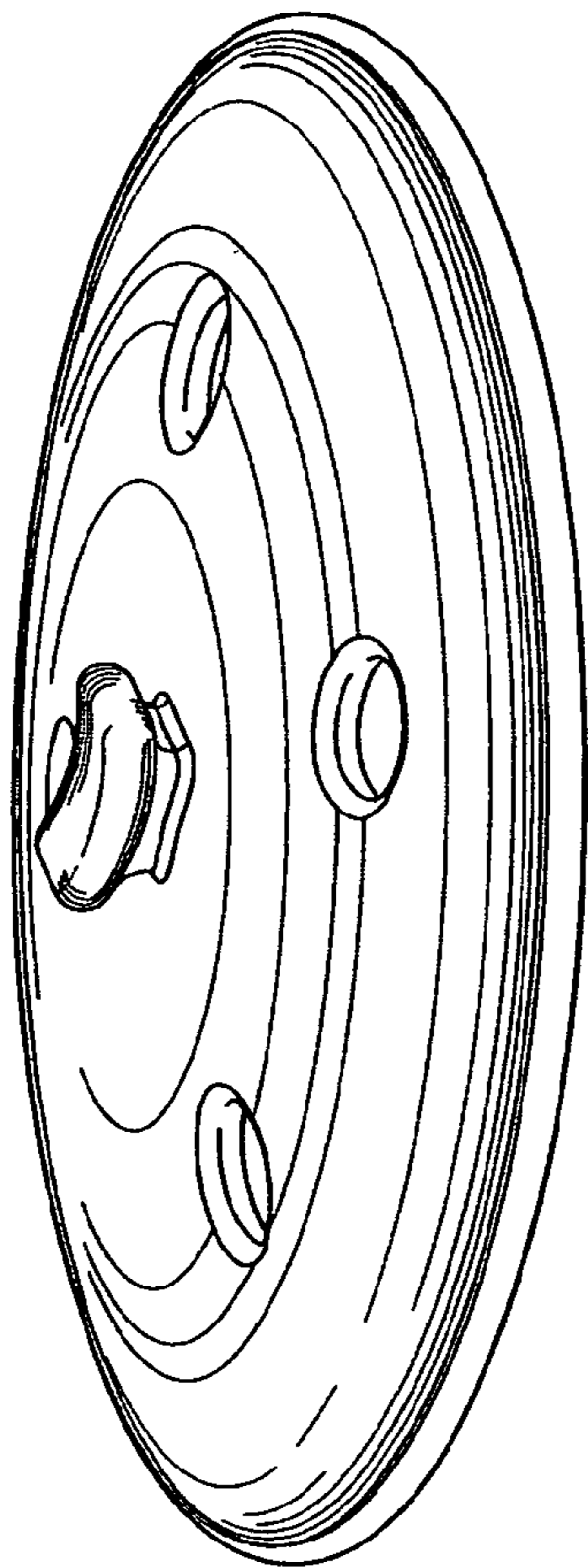

Fig. 5

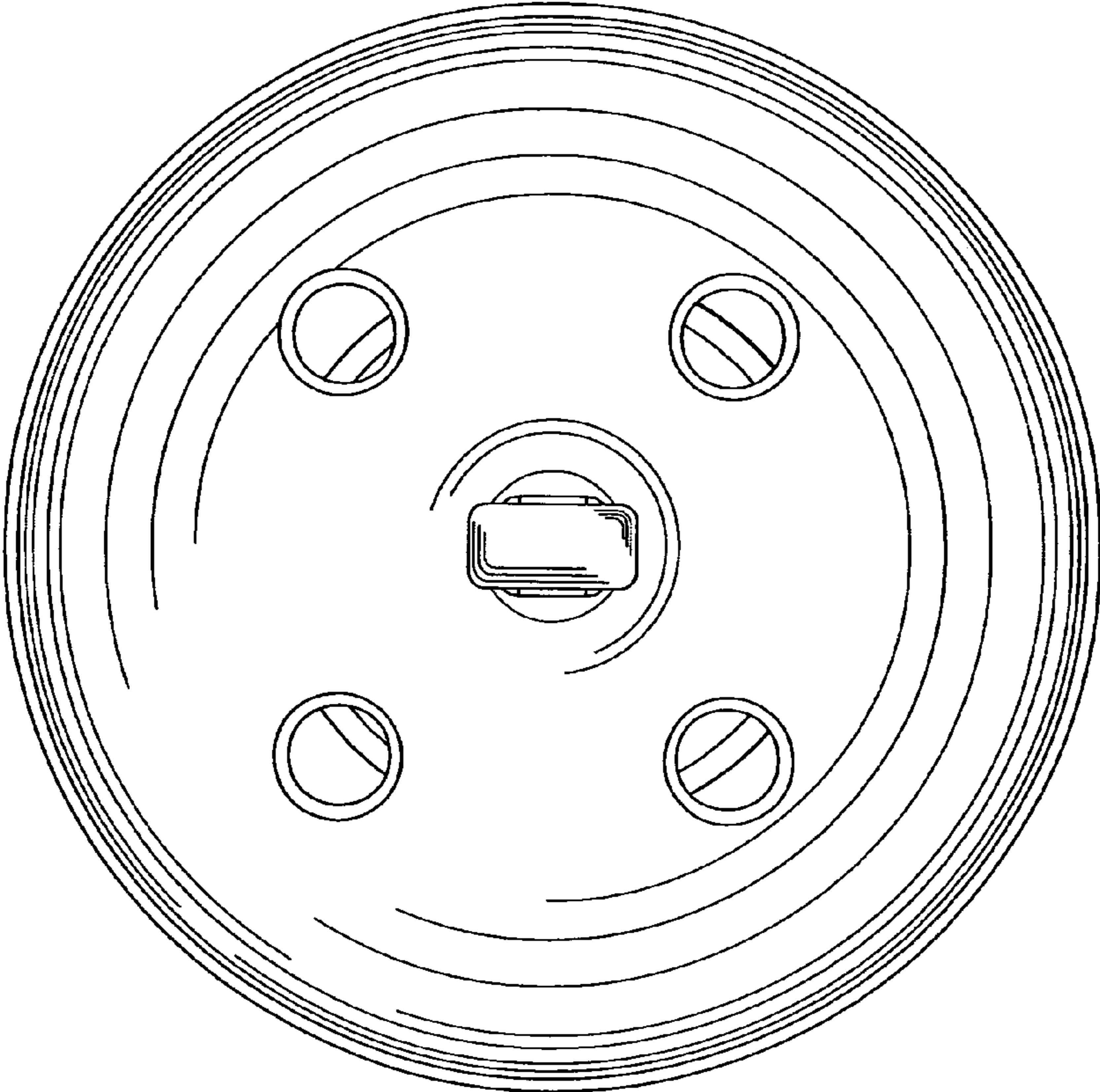

Fig.6

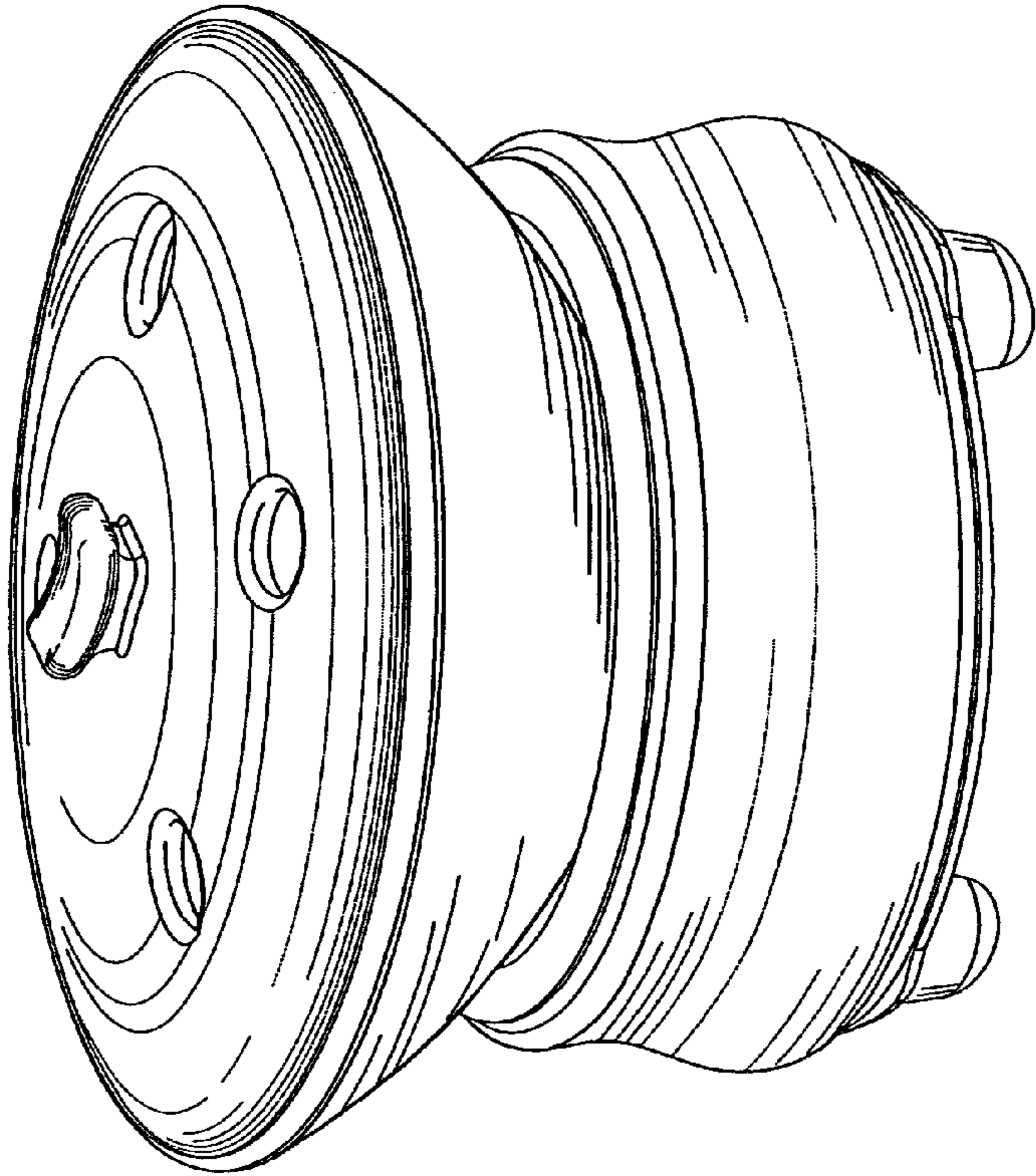

Fig. 7

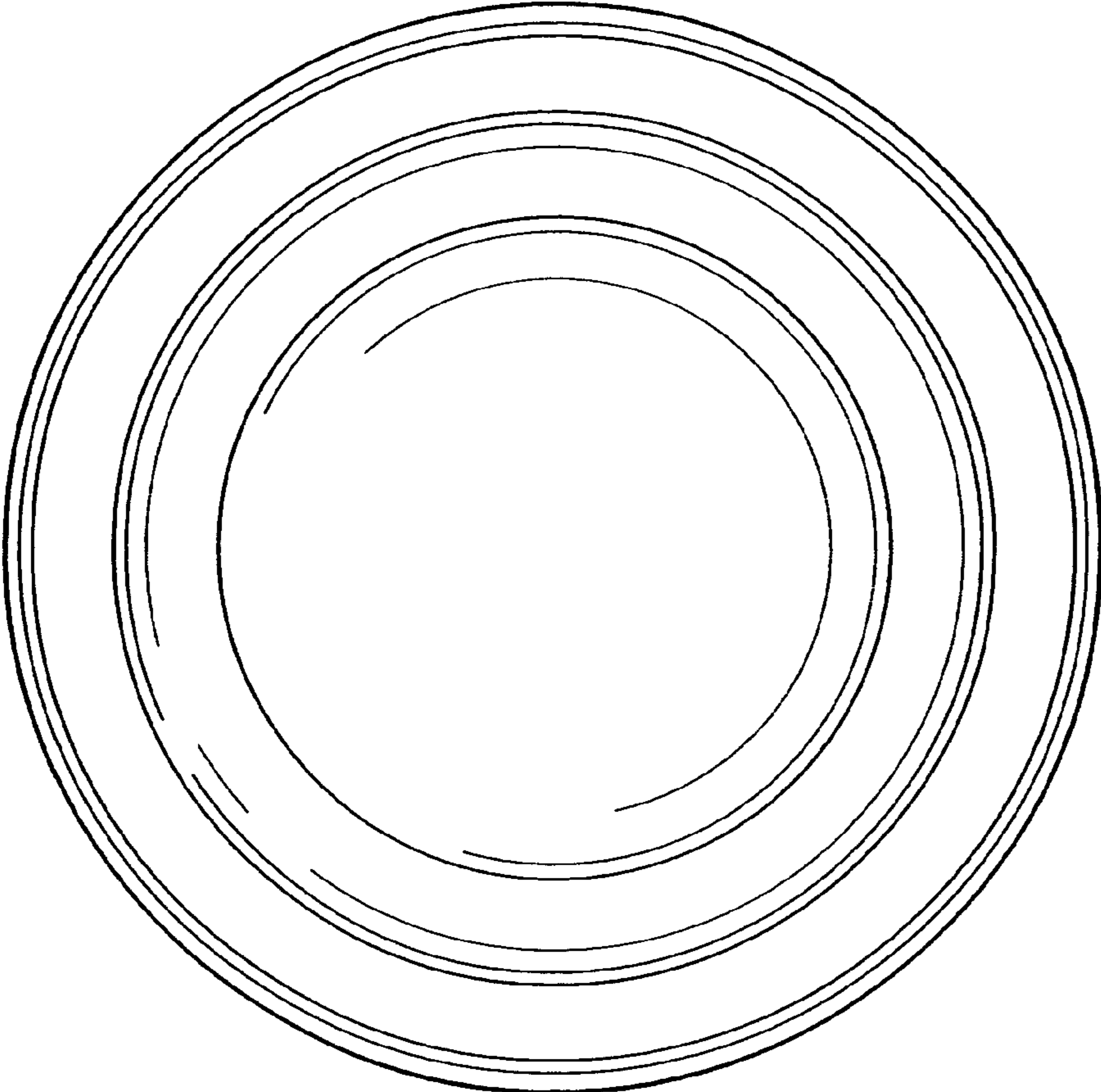

Fig. 8

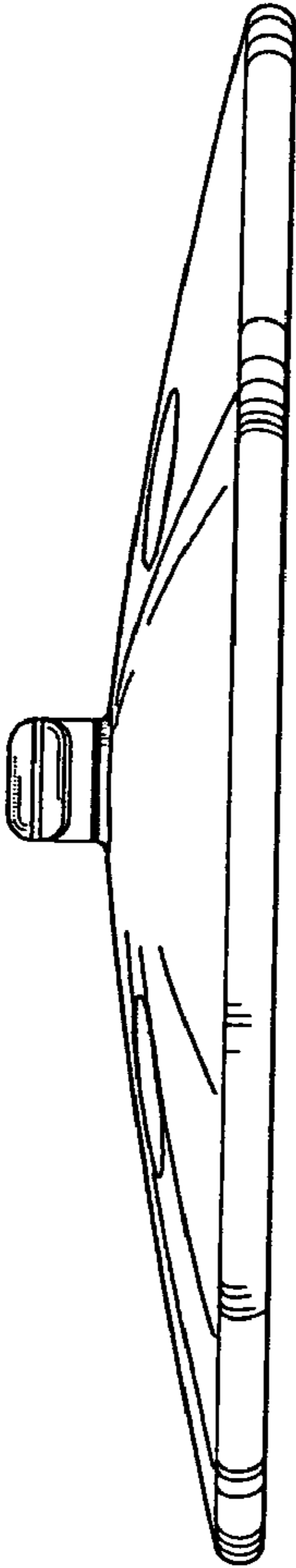

Fig.9

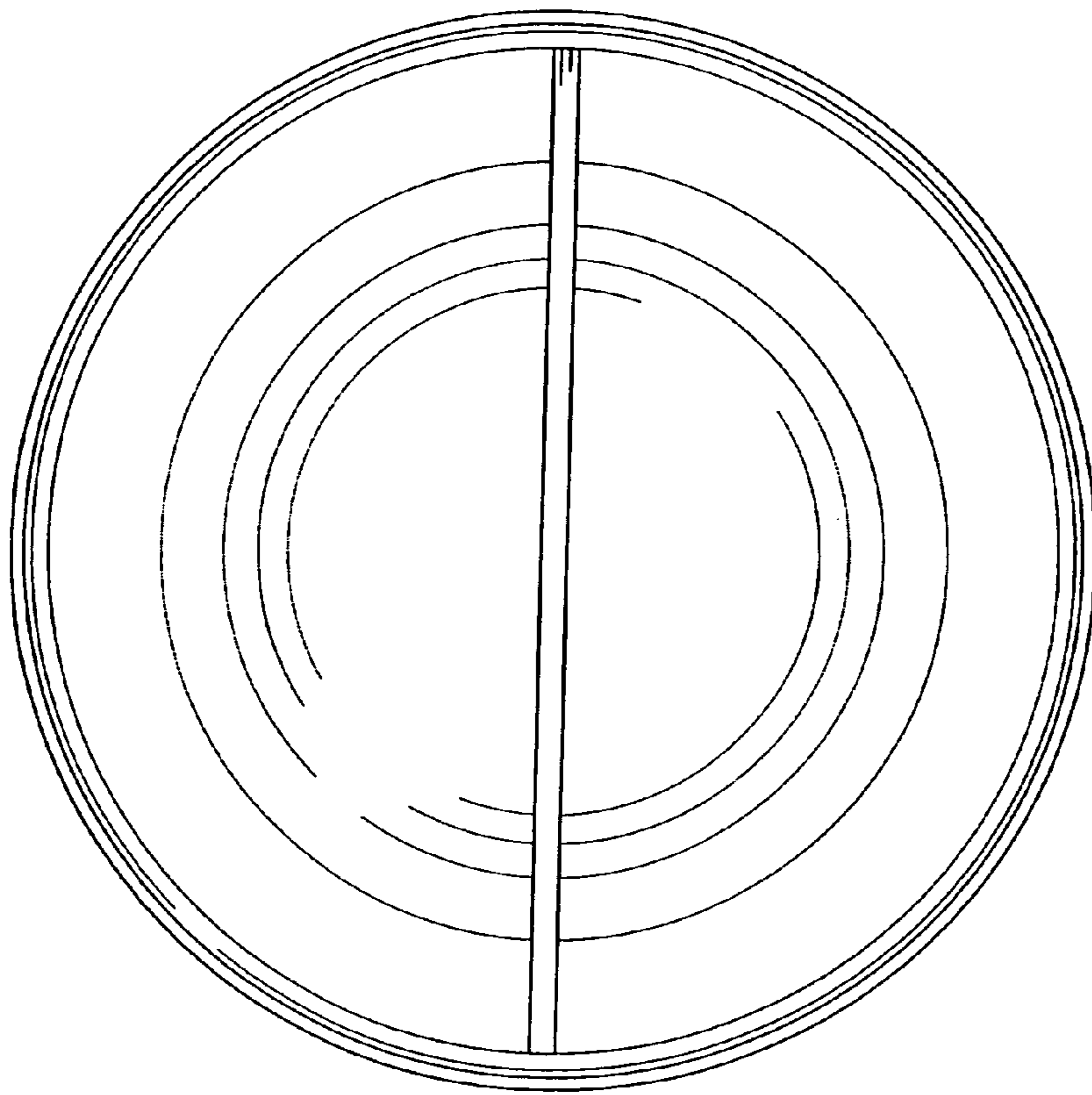

Fig.10