



US00D616345S

(12) **United States Design Patent**
Bauer et al.

(10) **Patent No.:** **US D616,345 S**

(45) **Date of Patent:** **** May 25, 2010**

(54) **SIDE MIRROR FOR A VEHICLE**

(75) Inventors: **Karlheinz Bauer**, Esslingen (DE);
Ulrich Baur, Stuttgart (DE);
Hans-Dieter Futschik, Gechingen (DE);
Steffen Koehl, Stuttgart (DE);
Karl-Heinz Naegele, Bondorf (DE)

(73) Assignee: **Daimler AG**, Stuttgart (DE)

(**) Term: **14 Years**

(21) Appl. No.: **29/311,363**

(22) Filed: **Mar. 3, 2009**

(30) **Foreign Application Priority Data**

Sep. 4, 2008 (DE) 402008004192

(51) **LOC (9) Cl.** **12-16**

(52) **U.S. Cl.** **D12/187**

(58) **Field of Classification Search** D12/187,
D12/188-189, 96; D6/309, 300; 359/838,
359/841, 843, 844, 868, 871, 604, 881, 514,
359/866; 248/479-483, 475.1

See application file for complete search history.

(56) **References Cited**

U.S. PATENT DOCUMENTS

D478,853 S * 8/2003 Boyer D12/187

(Continued)

Primary Examiner—Caron Veynar

Assistant Examiner—Katrina A Kile

(74) *Attorney, Agent, or Firm*—Crowell & Moring LLP

(57) **CLAIM**

The ornamental design for a side mirror for a vehicle, as shown and described.

DESCRIPTION

This application contains subject matter related to the following co-pending U.S. patent applications:

U.S. patent application Ser. No. 29/309,073, filed Jun. 18, 2008;

U.S. patent application Ser. No. 29/309,775, filed Oct. 7, 2008;

U.S. patent application Ser. No. 29/311,361, filed herewith and entitled “Side Mirror for a Vehicle”; and

U.S. patent application Ser. No. 29/311,362, filed herewith and entitled “Foot for a Side Mirror for a Vehicle”.

FIG. 1 is a rear perspective view of a first embodiment of a side mirror for a vehicle according to our novel design;

FIG. 2 is a side perspective view thereof;

FIG. 3 is a rear view thereof;

FIG. 4 is a front view thereof;

FIG. 5 is a side view thereof; and

FIG. 6 is a top view thereof.

FIG. 7 is a side perspective view of a second embodiment of the side mirror for a vehicle according to our novel design;

FIG. 8 is a side perspective view thereof;

FIG. 9 is a rear view thereof;

FIG. 10 is a front view thereof; and

FIG. 11 is a top view thereof.

FIG. 12 is a rear perspective view of a third embodiment of the side mirror for a vehicle according to our novel design;

FIG. 13 is a side perspective view thereof;

FIG. 14 is a rear view thereof;

FIG. 15 is a front view thereof;

FIG. 16 is a side view thereof; and

FIG. 17 is a top view thereof.

FIG. 18 is a side perspective view of a fourth embodiment of the side mirror for a vehicle according to our novel design;

FIG. 19 is a side perspective view thereof;

FIG. 20 is a rear view thereof;

FIG. 21 is a front view thereof; and,

FIG. 22 is a top view thereof.

The third embodiment is a mirror image of the side mirror for a vehicle as shown in FIGS. 1-6. The fourth embodiment is a mirror image of the side mirror for a vehicle as shown in FIGS. 7-11.

In the drawings, the broken lines show portions of a side mirror for a vehicle and form no part of the claimed design.

1 Claim, 14 Drawing Sheets

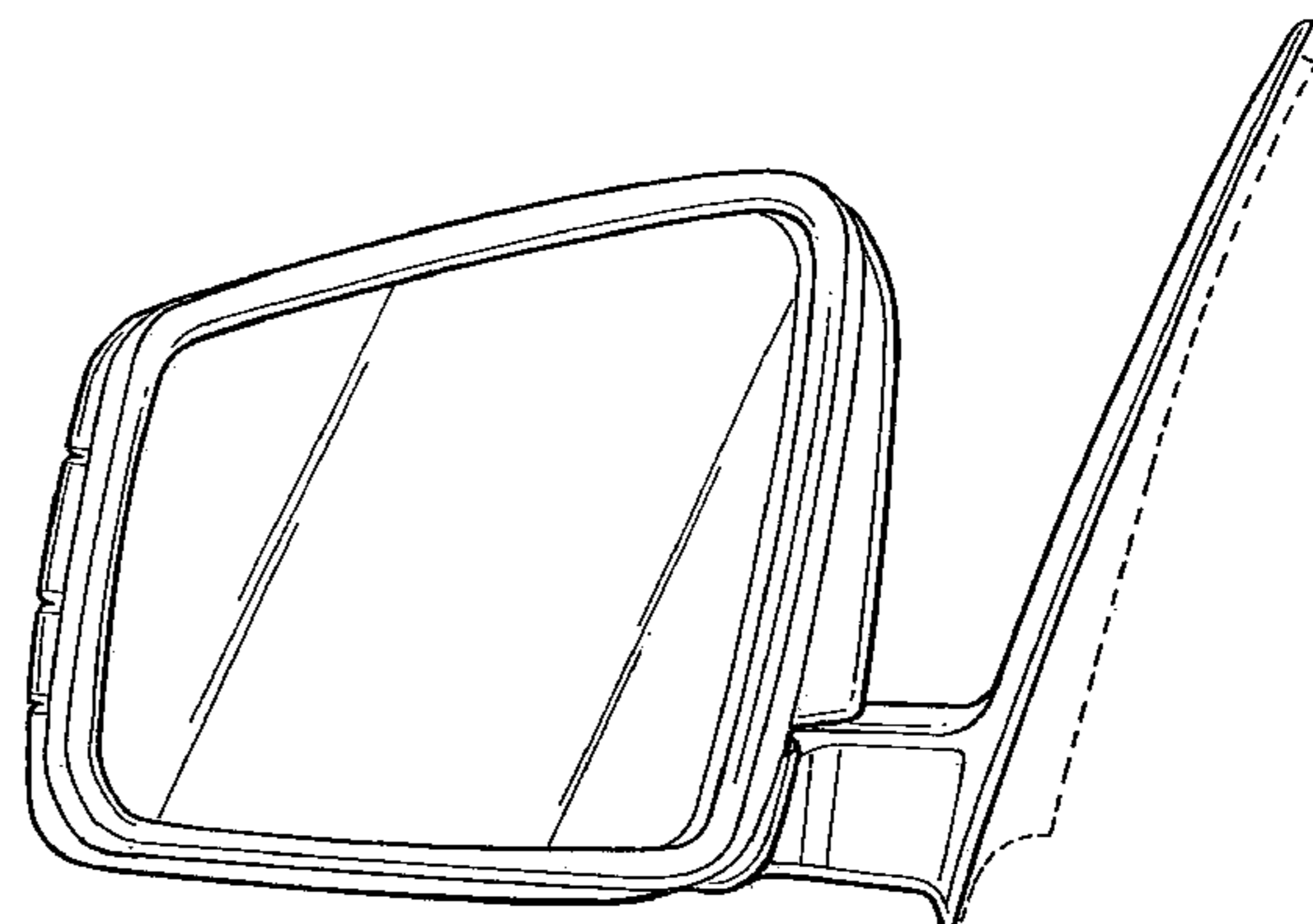
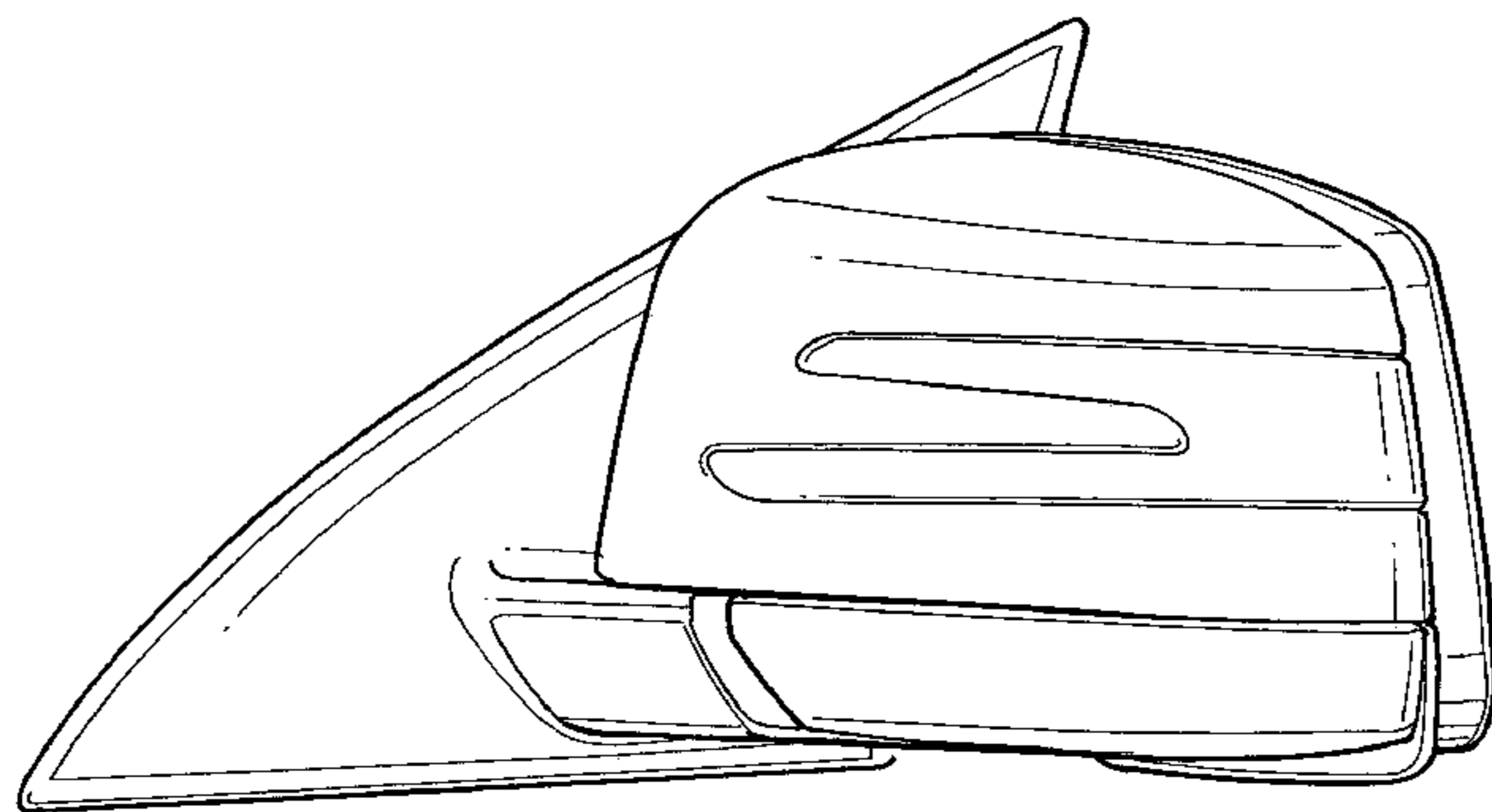

US D616,345 S

Page 2

U.S. PATENT DOCUMENTS					
D574,761 S	8/2008	Futschik et al.	7,600,877 B2 *	10/2009	Behbehani 359/868
D575,707 S	8/2008	Futschik et al.	D603,774 S *	11/2009	Chen D12/187
D577,639 S *	9/2008	Choi et al. D12/187	2002/0141085 A1 *	10/2002	Whitehead et al. 359/841
D578,047 S *	10/2008	Kaoud et al. D12/187	2004/0218272 A1 *	11/2004	Boddy 359/512
D587,638 S *	3/2009	Futschik et al. D12/187	2005/0174645 A1 *	8/2005	Boddy et al. 359/599
D587,639 S	3/2009	Futschik et al.	2005/0254153 A1 *	11/2005	Kawanishi 359/879
D589,859 S *	4/2009	Golden et al. D12/187	2009/0086346 A1 *	4/2009	Henion 359/841
			2009/0244744 A1 *	10/2009	Okamoto et al. 359/872
			* cited by examiner		

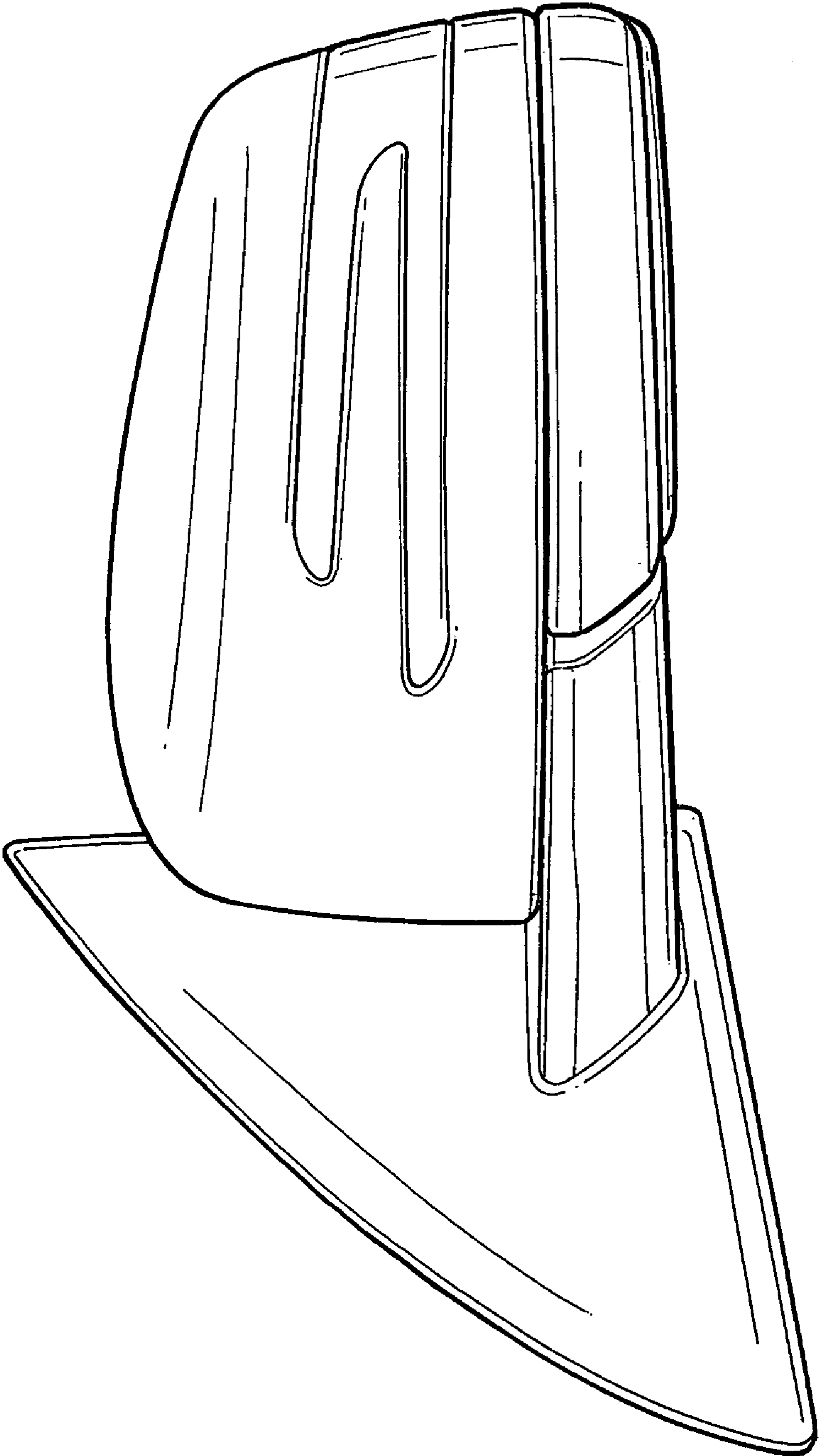

FIG. 1

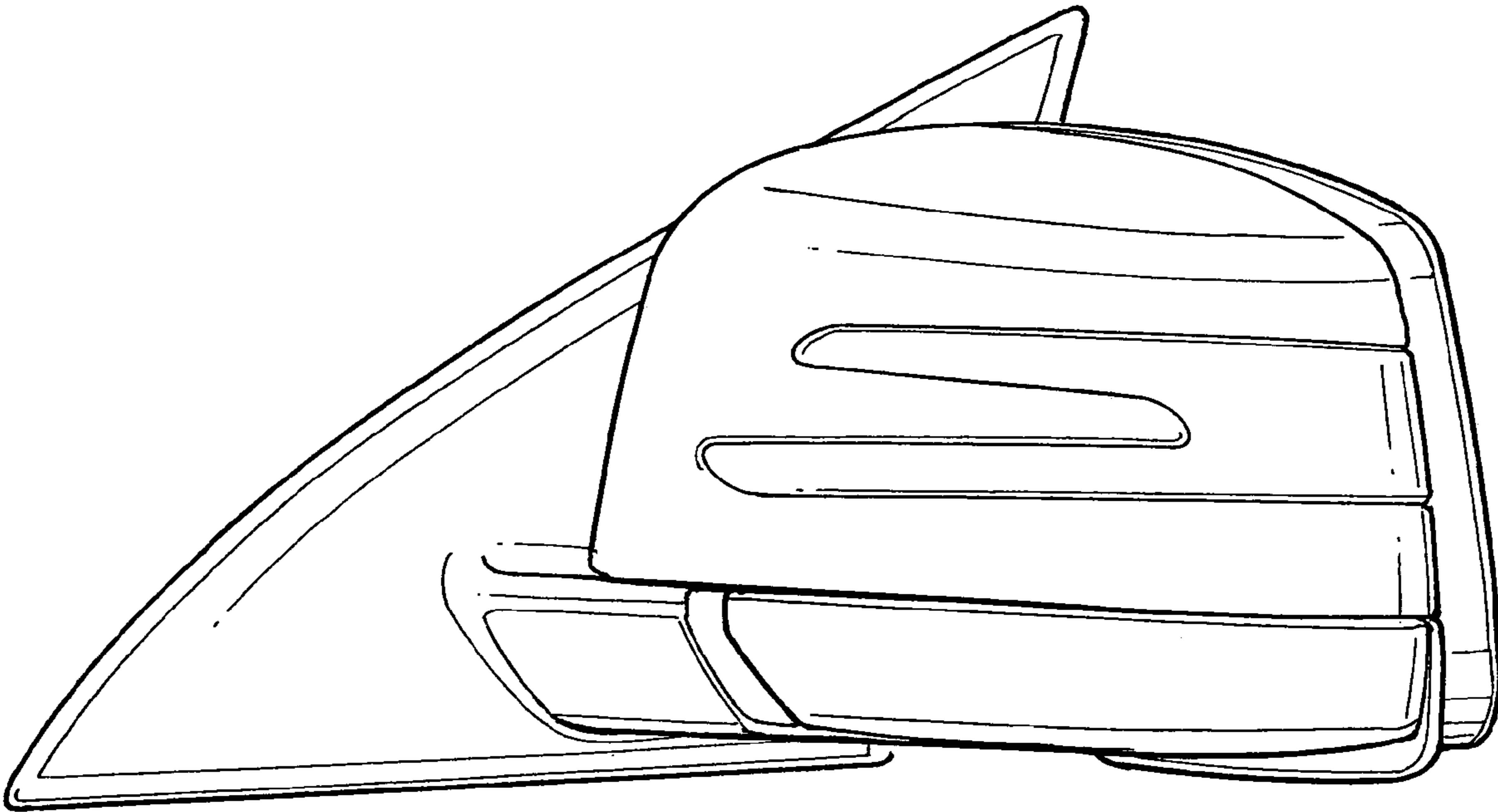

FIG. 2

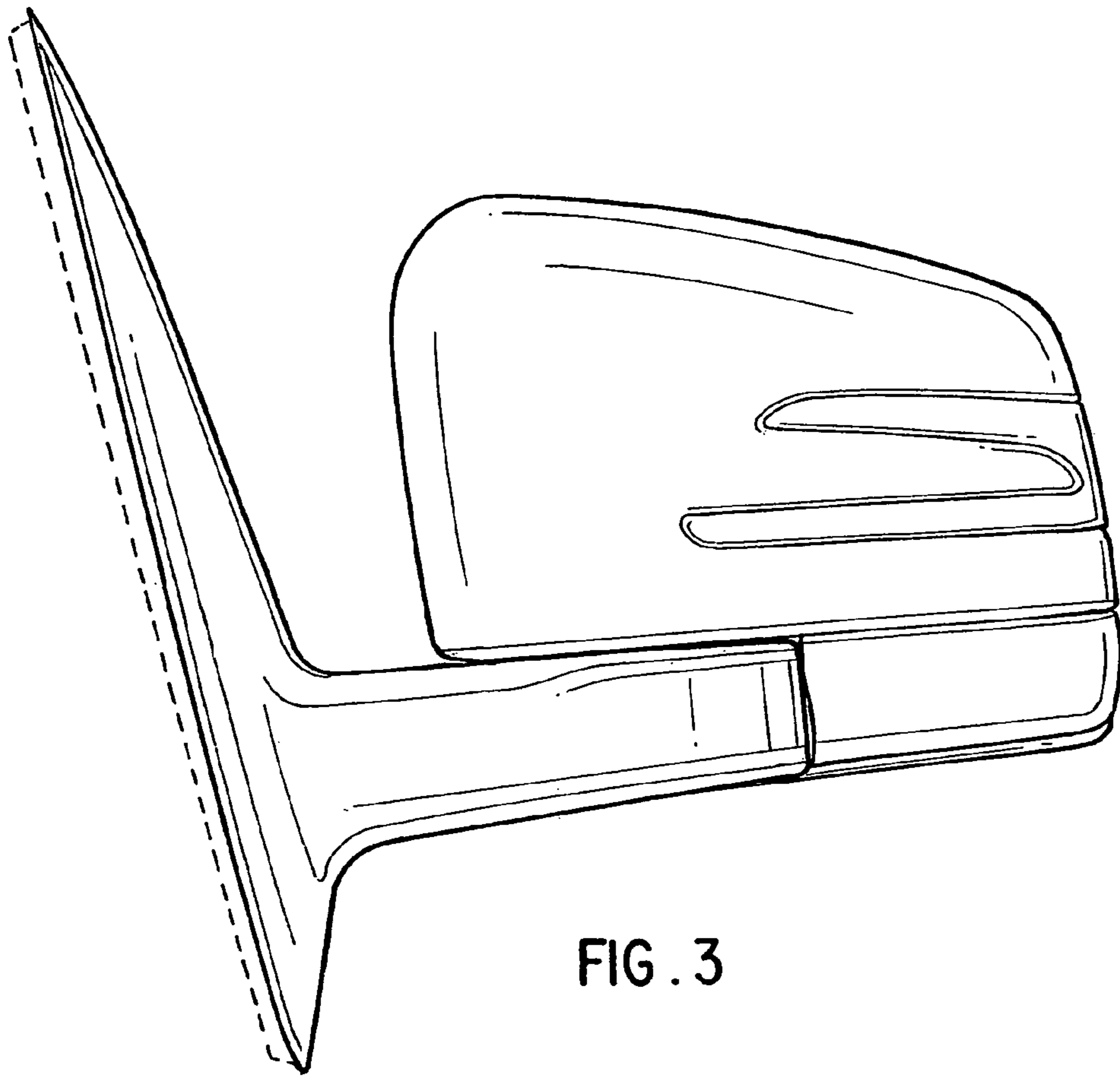

FIG. 3

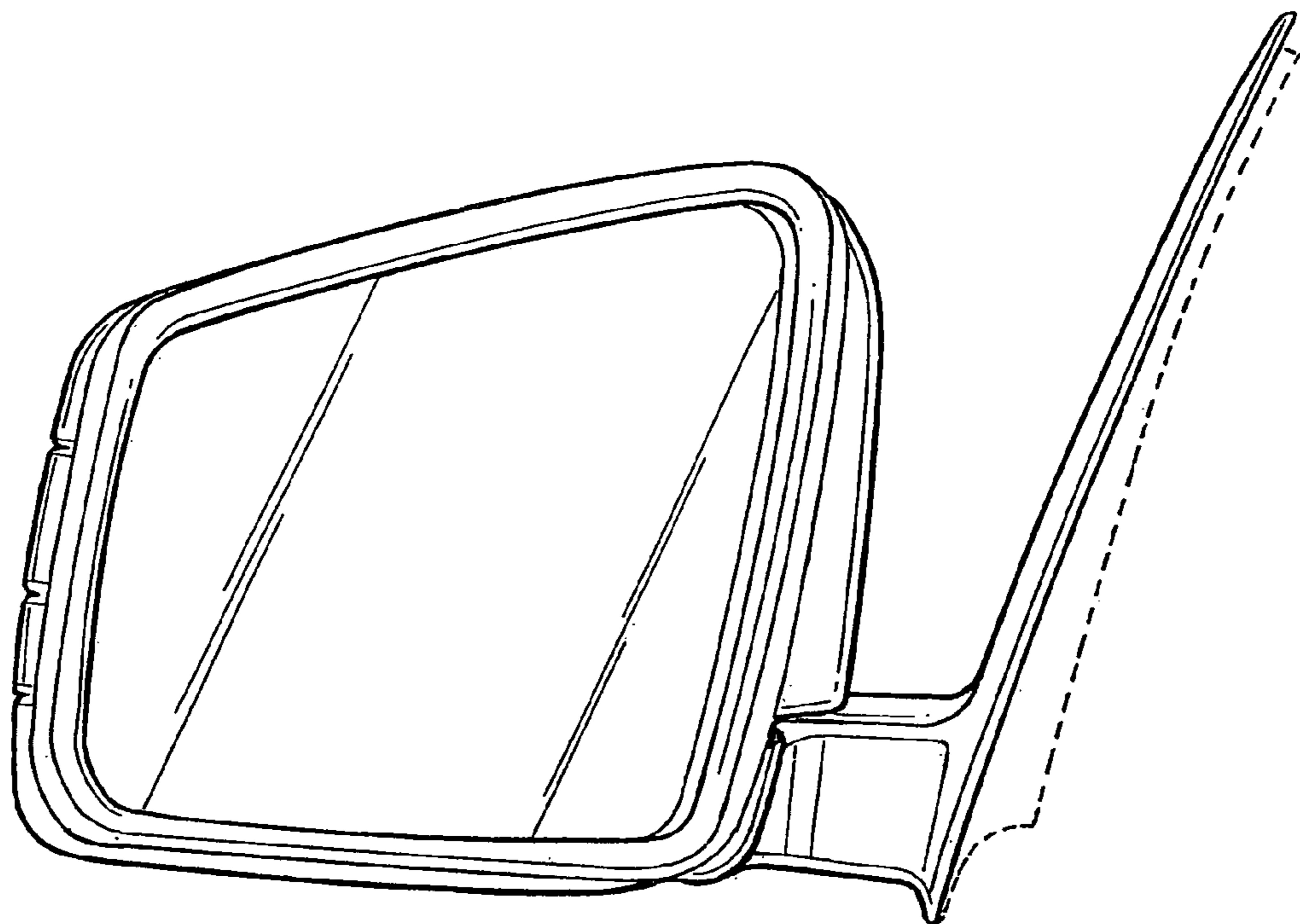

FIG. 4

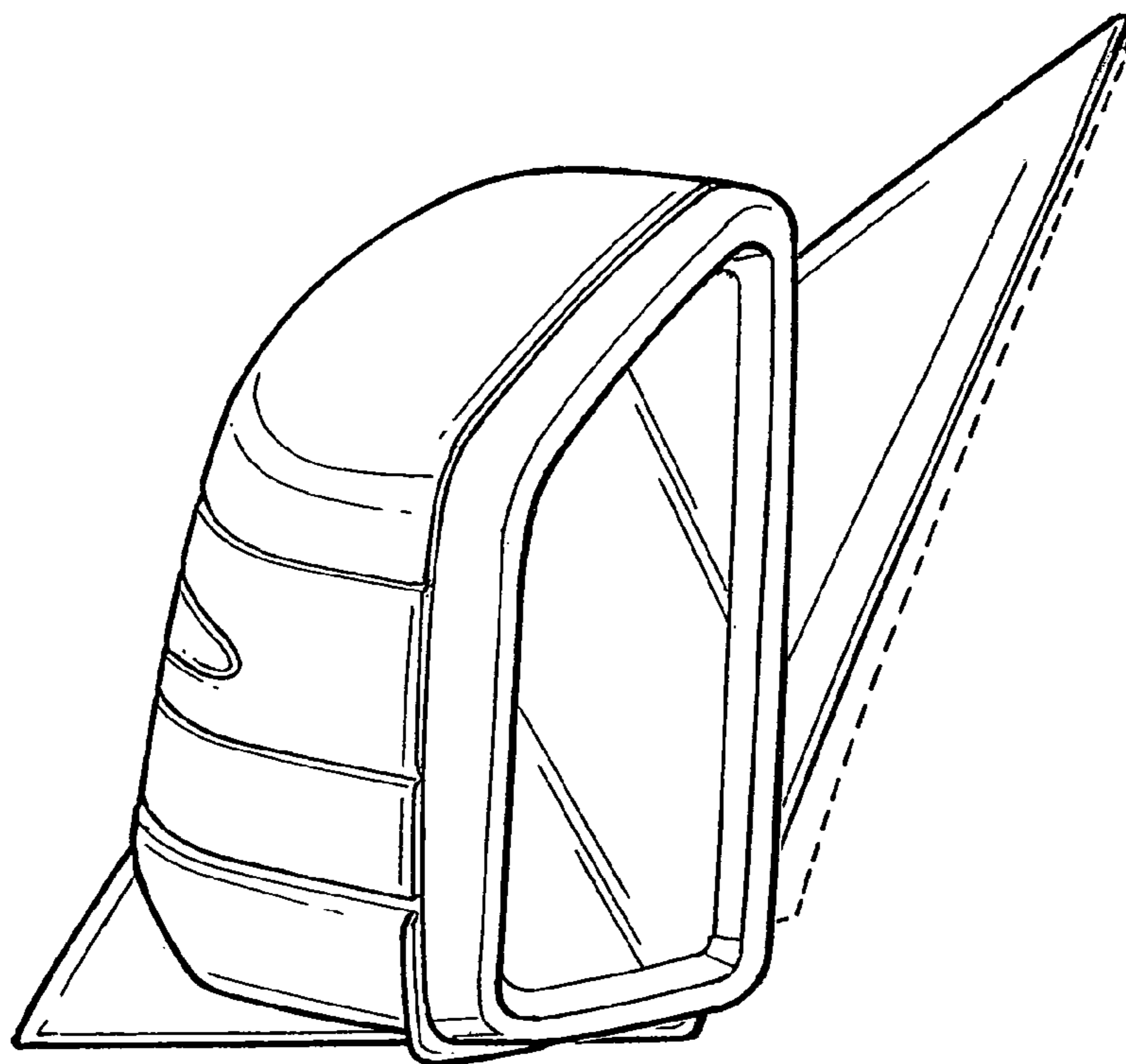

FIG. 5

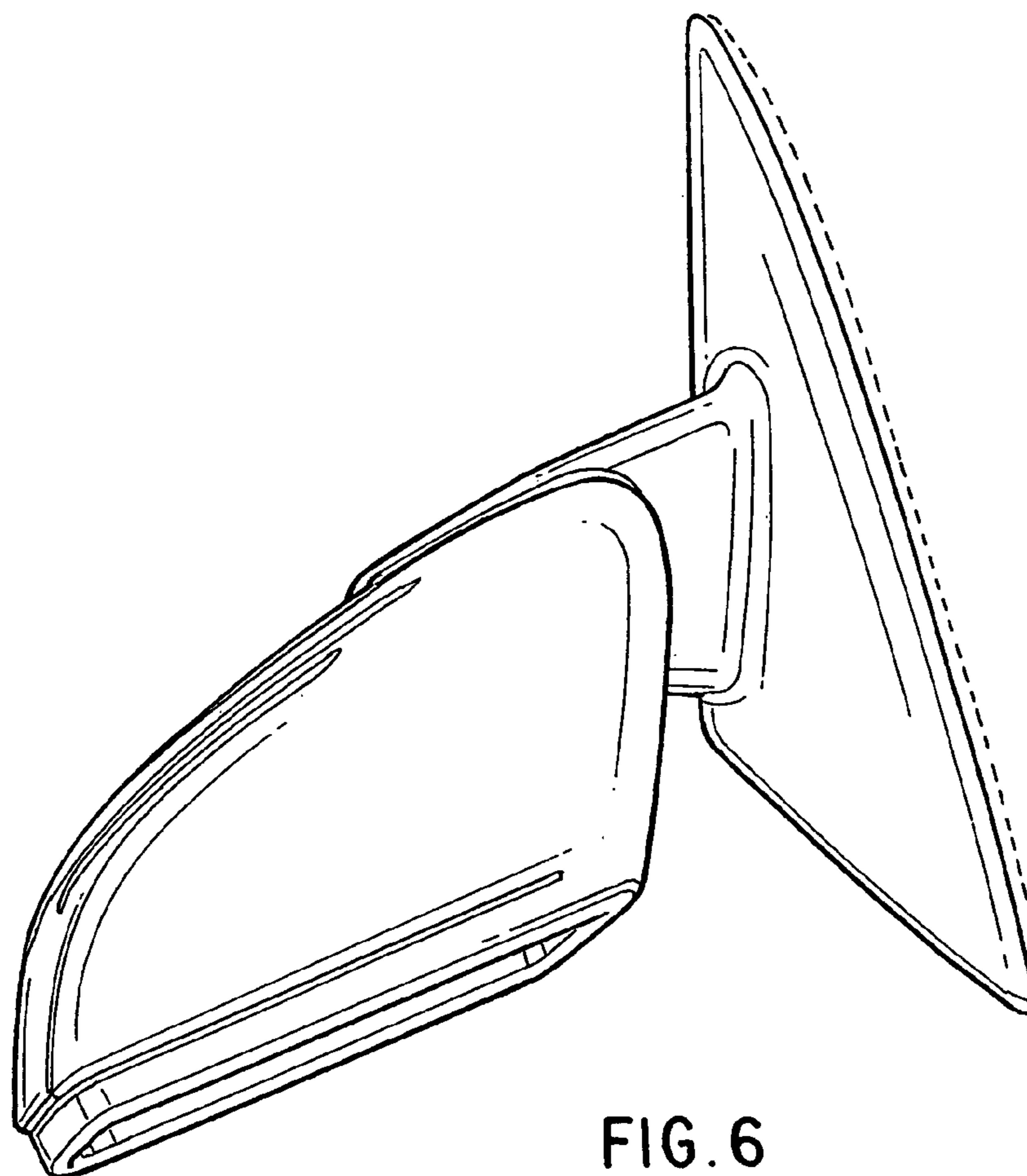

FIG. 6

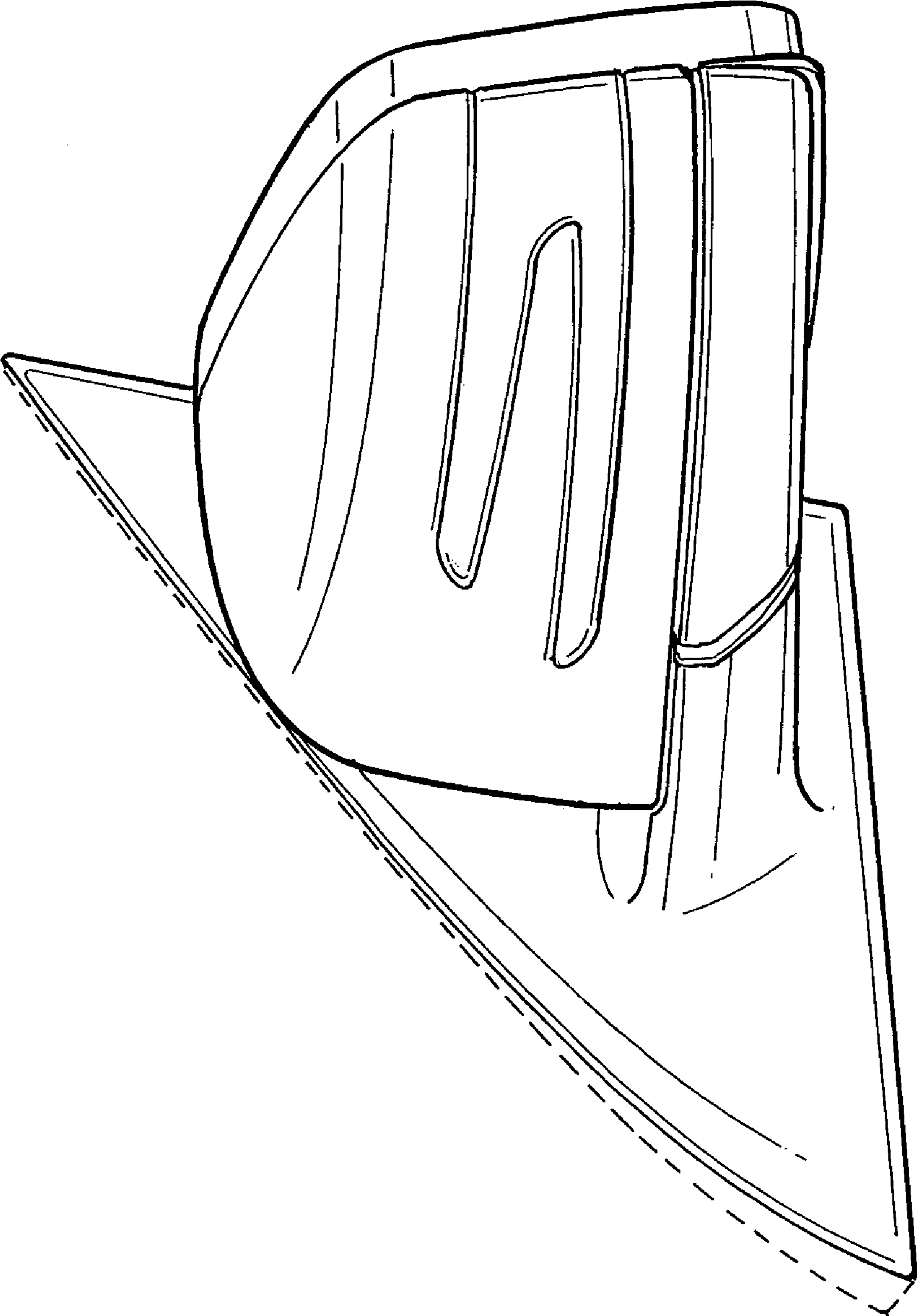

FIG. 7

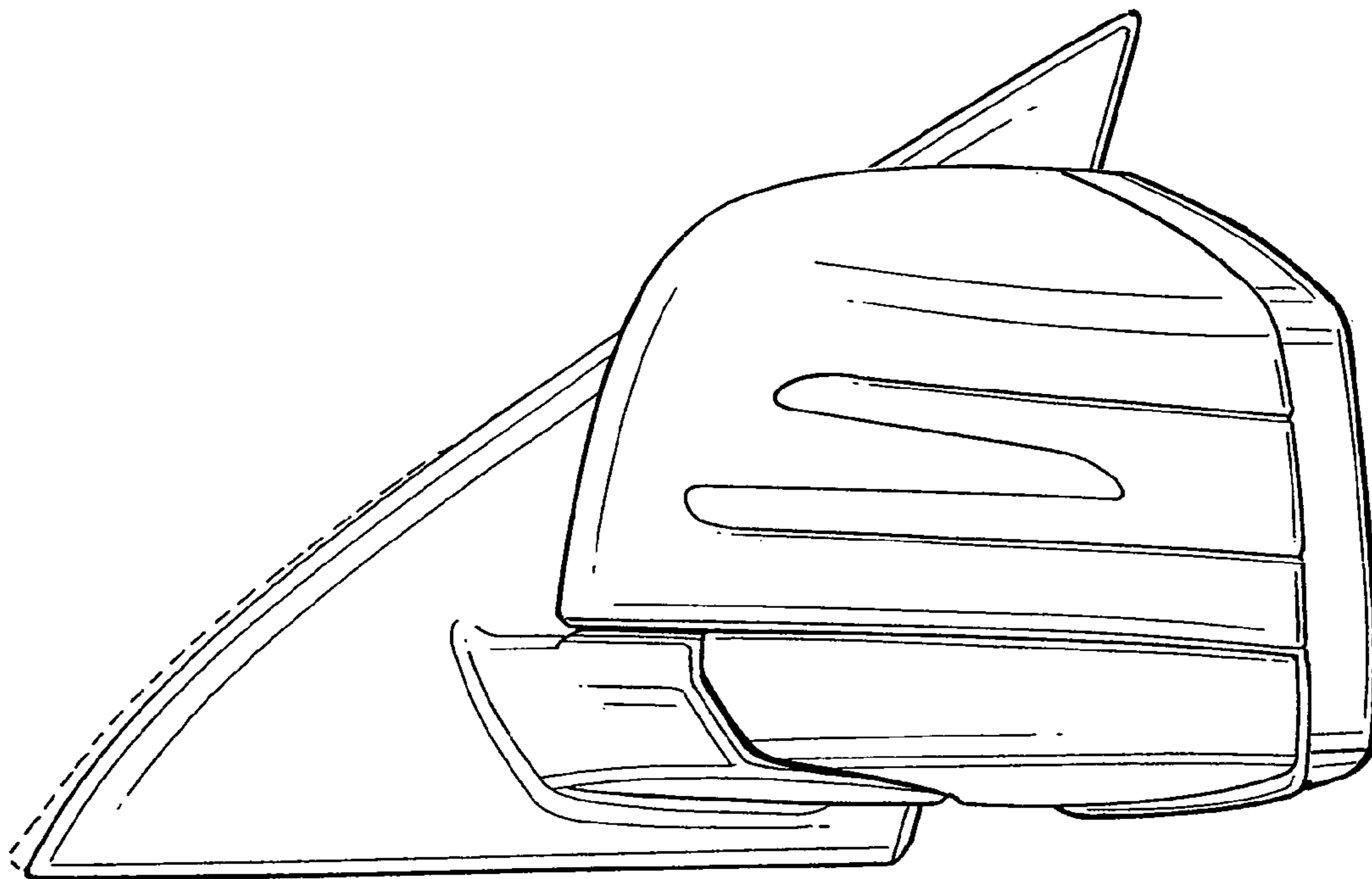

FIG. 8

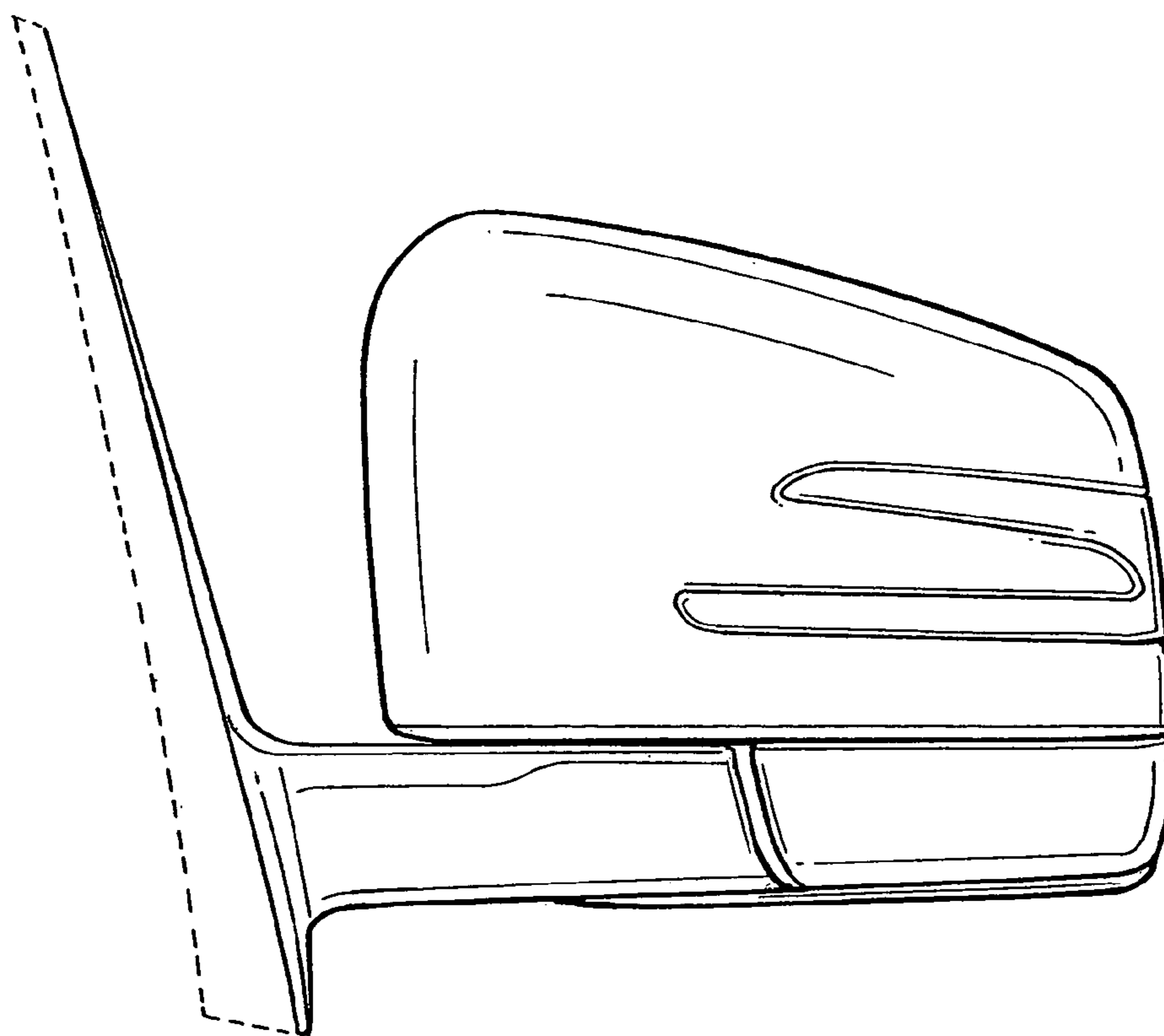

FIG. 9

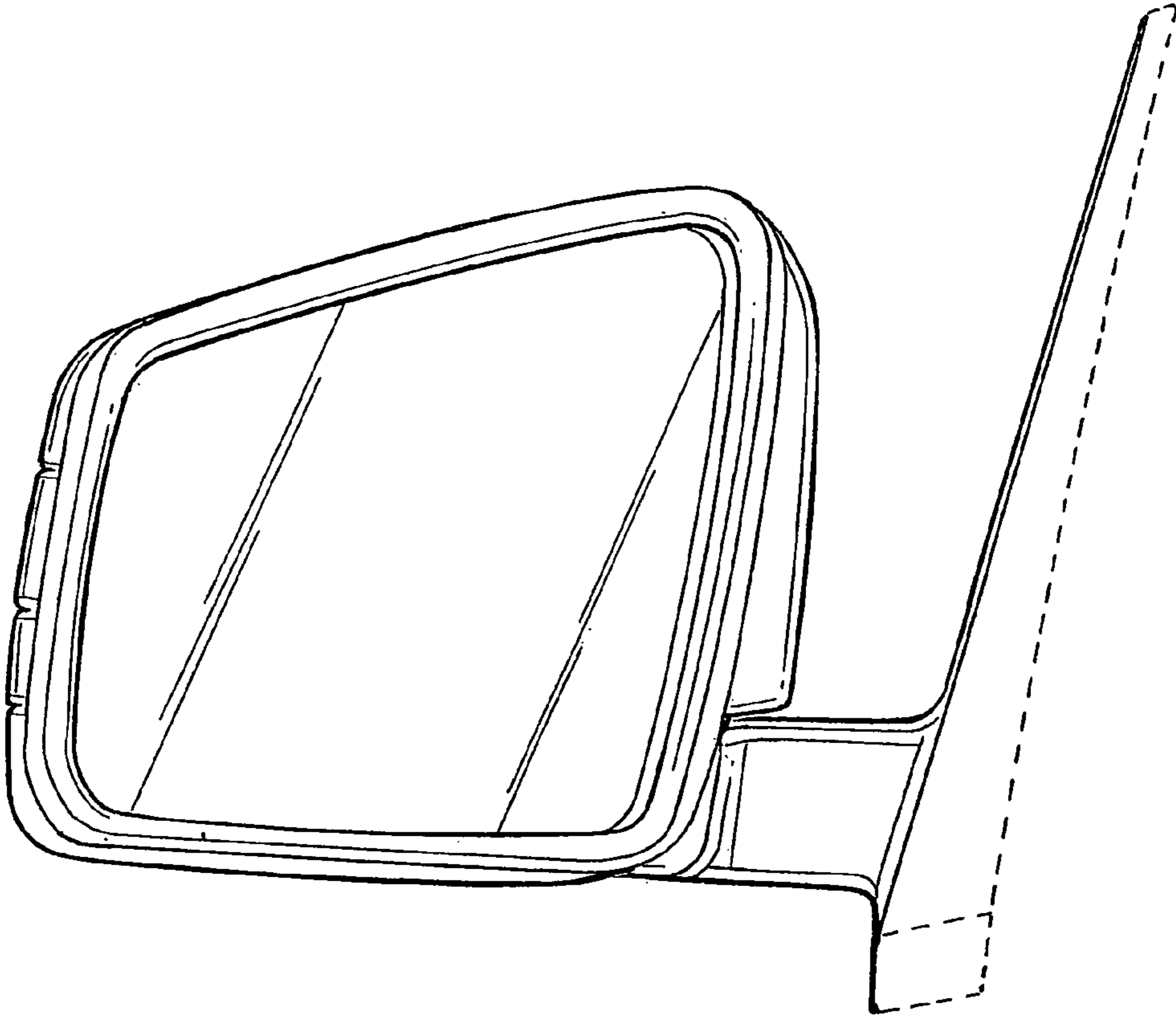

FIG. 10

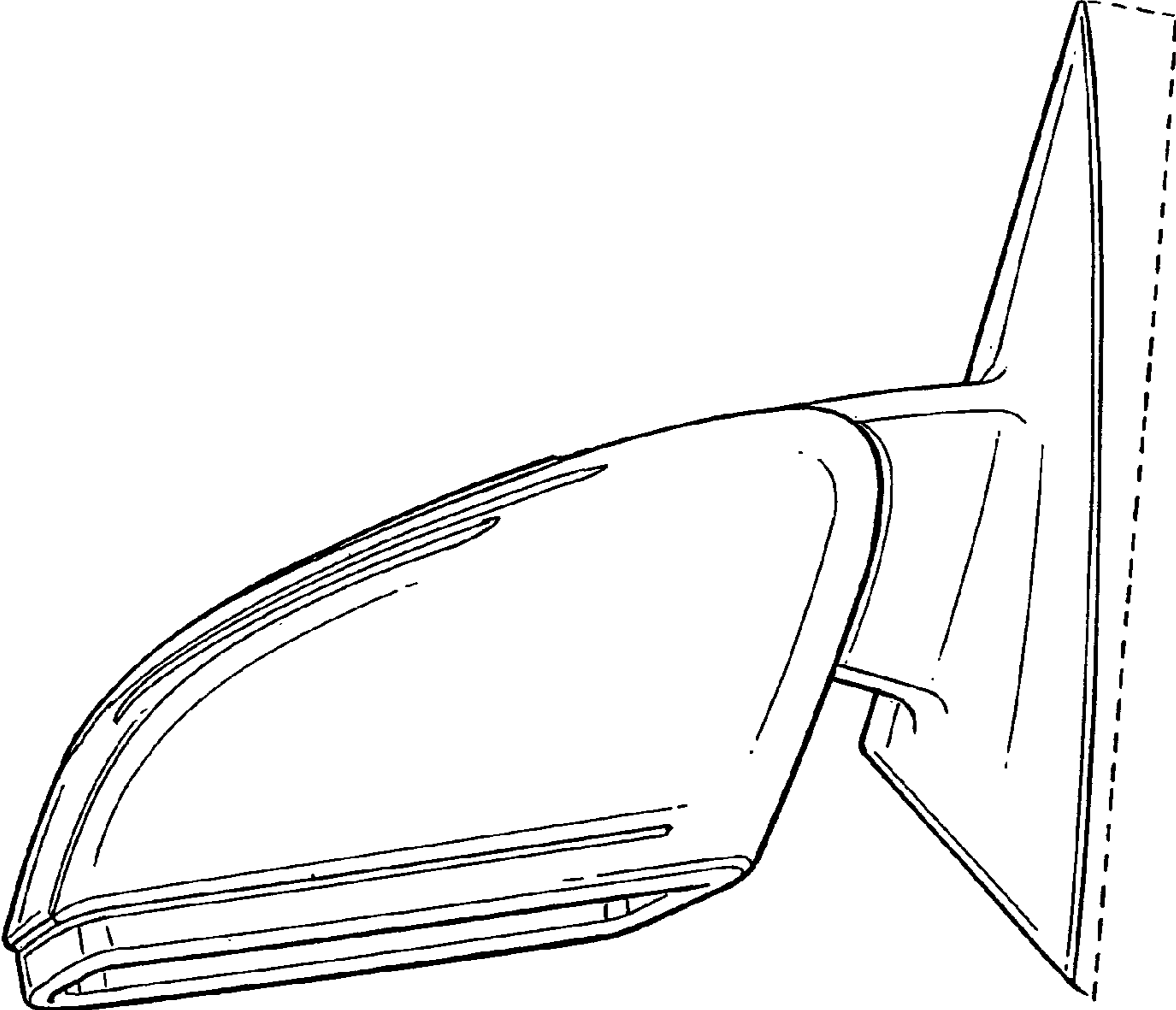

FIG. 11

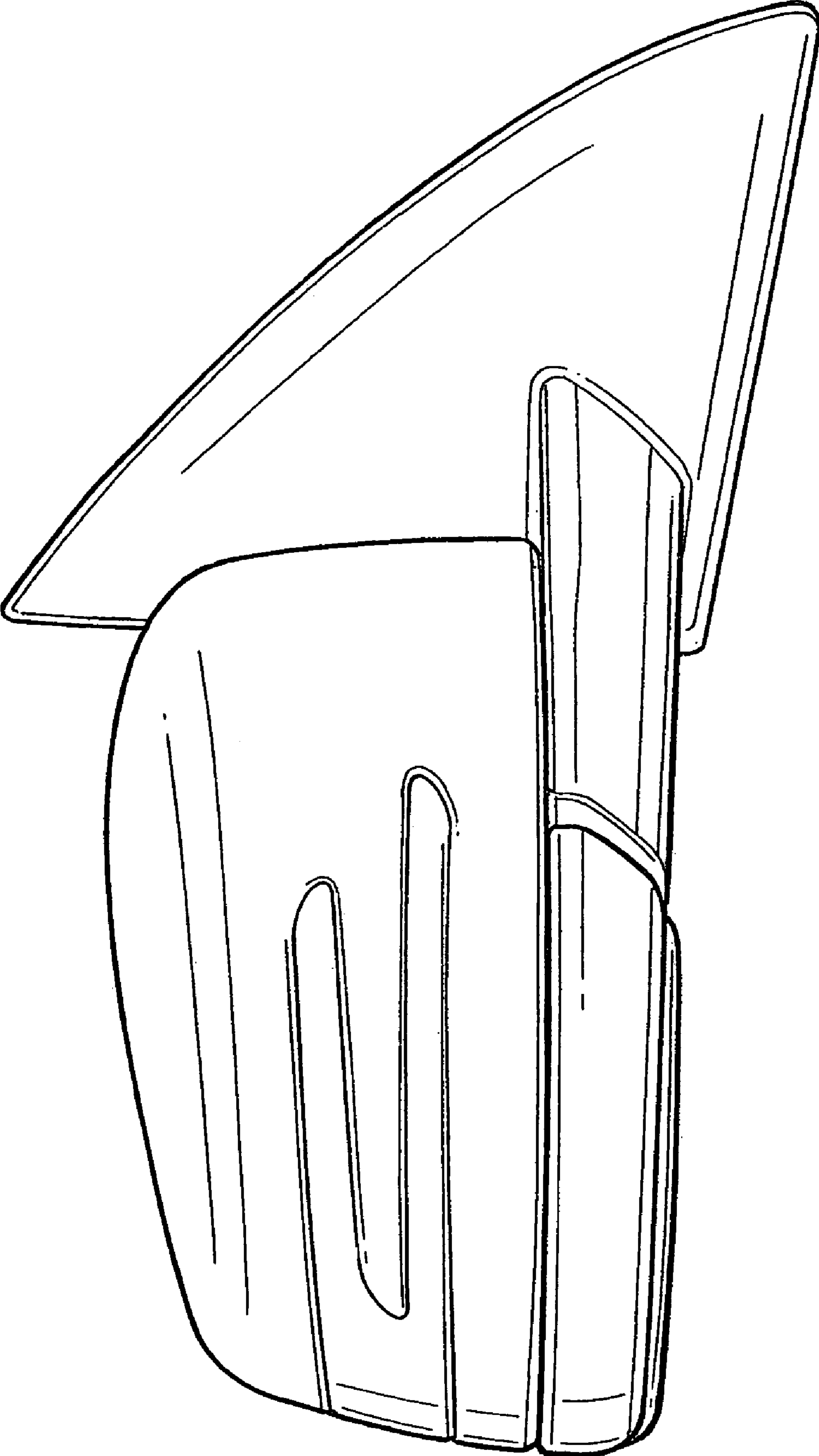

FIG. 12

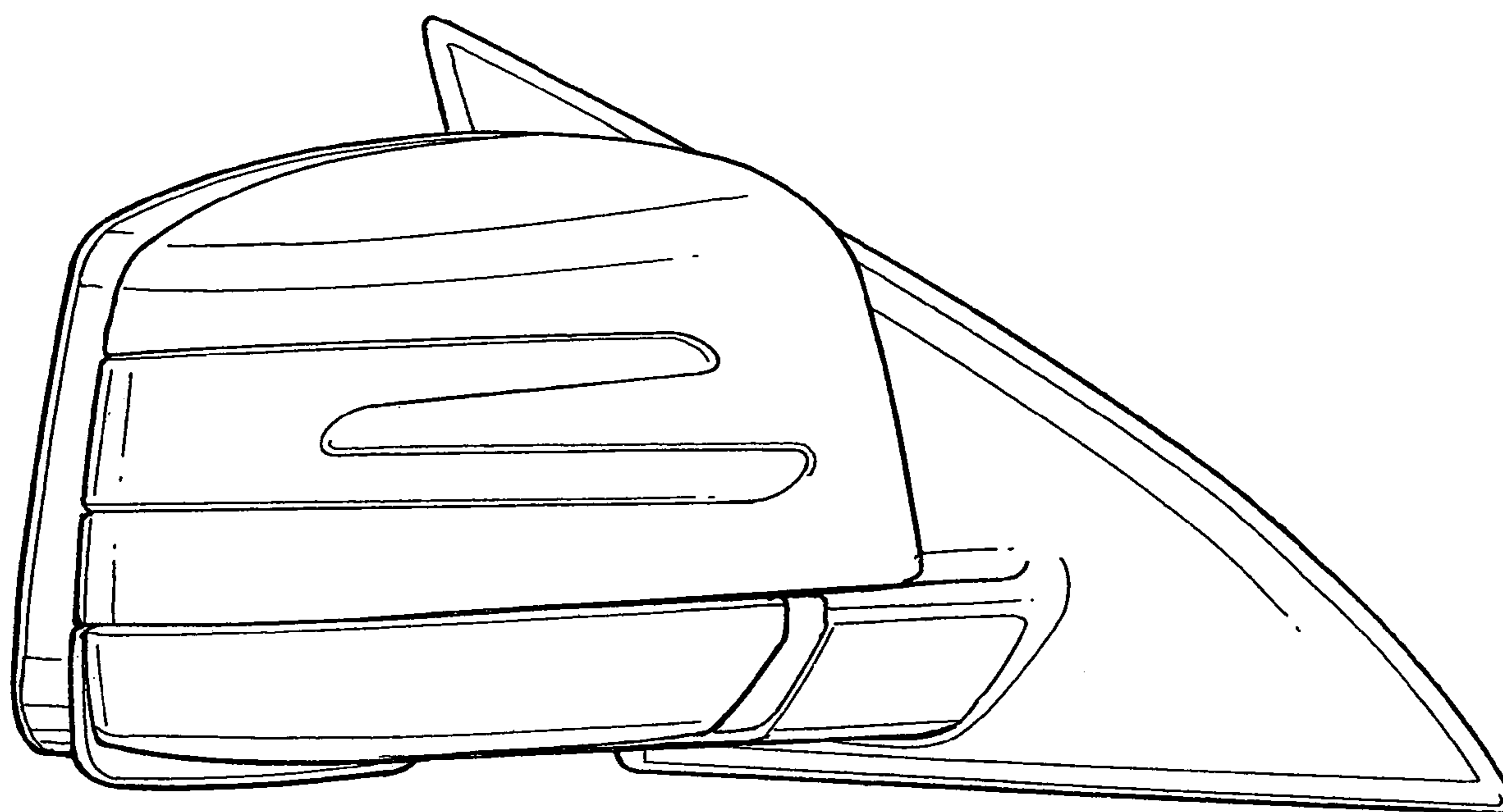

FIG. 13

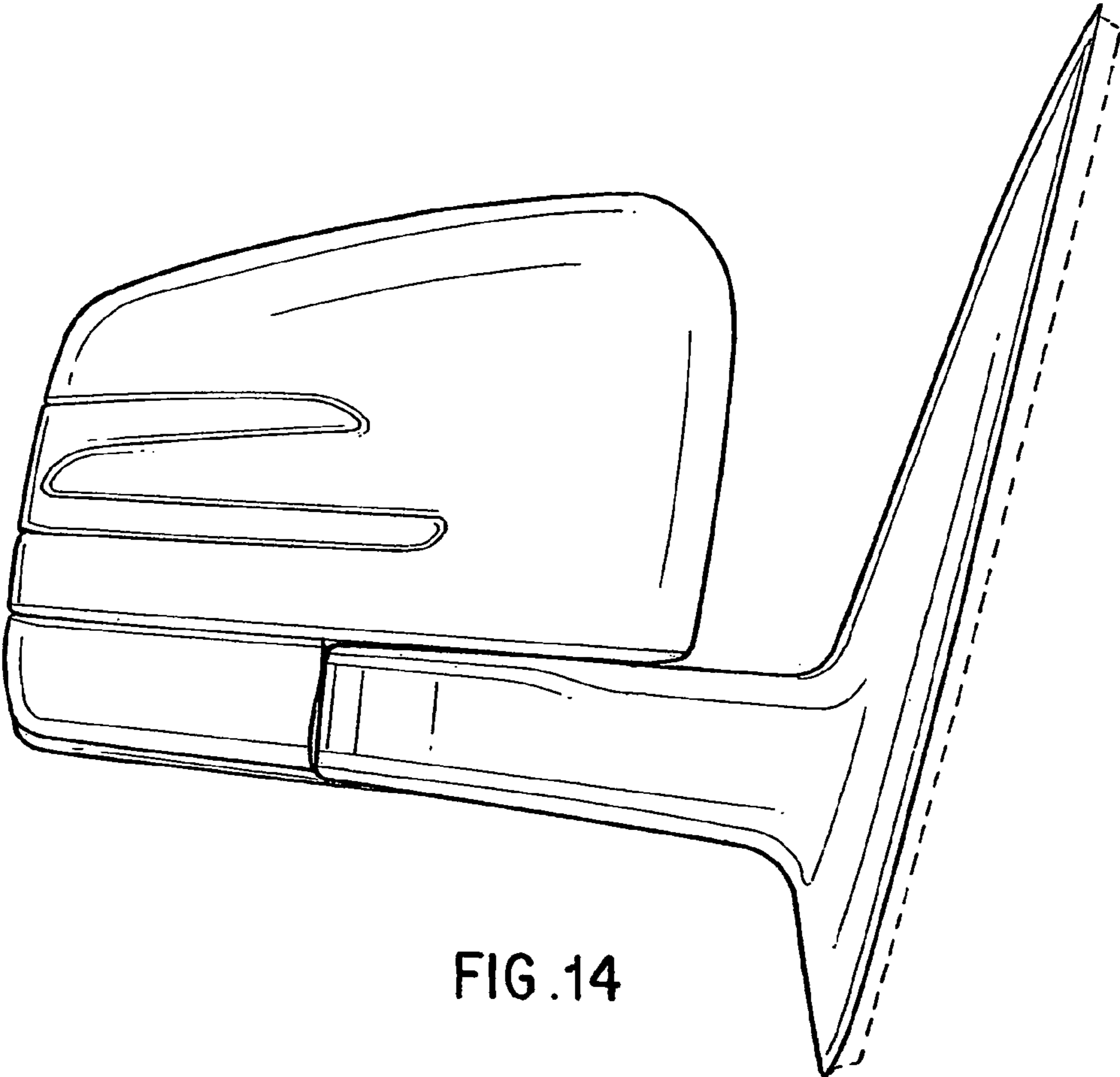

FIG. 14

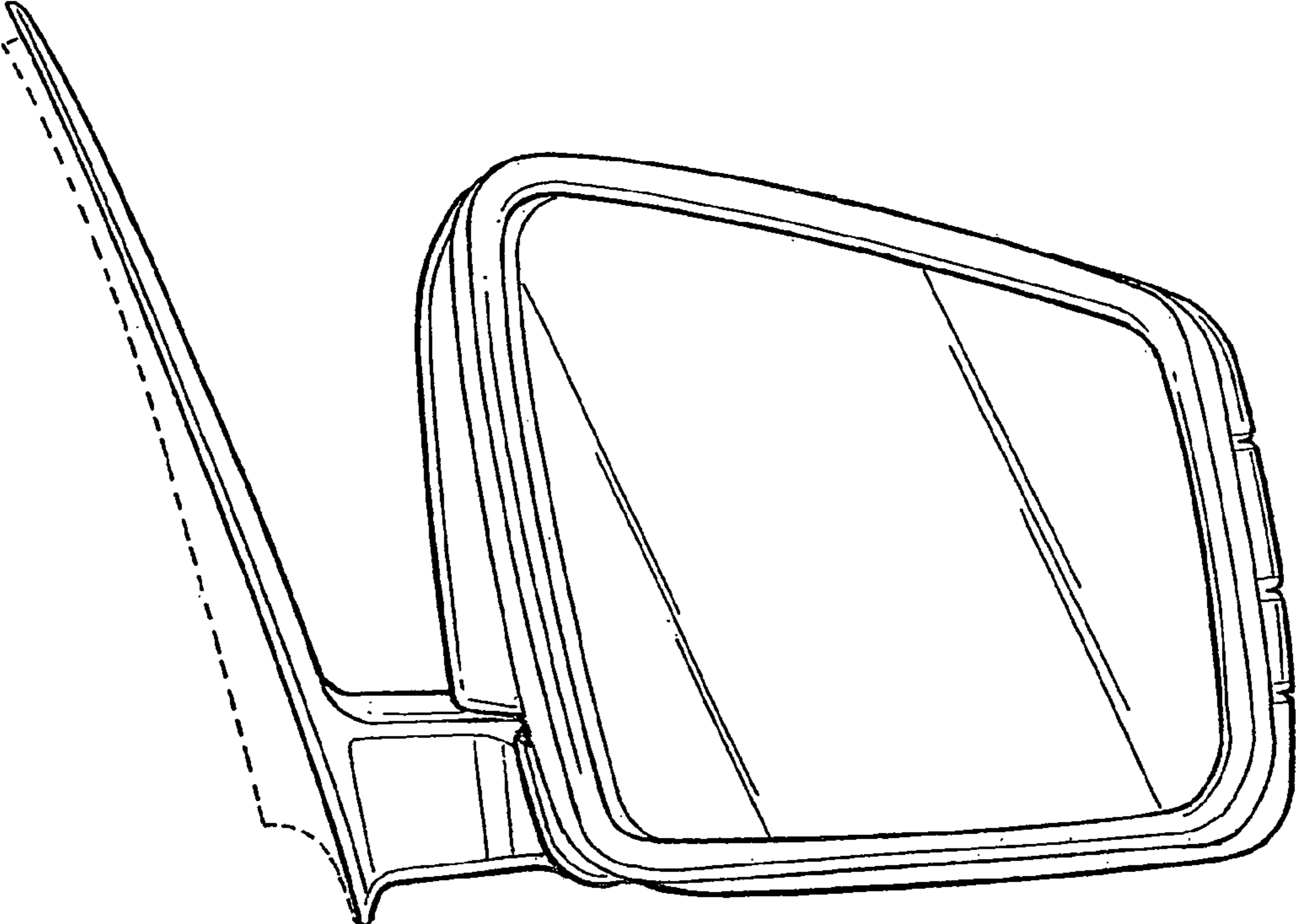

FIG. 15

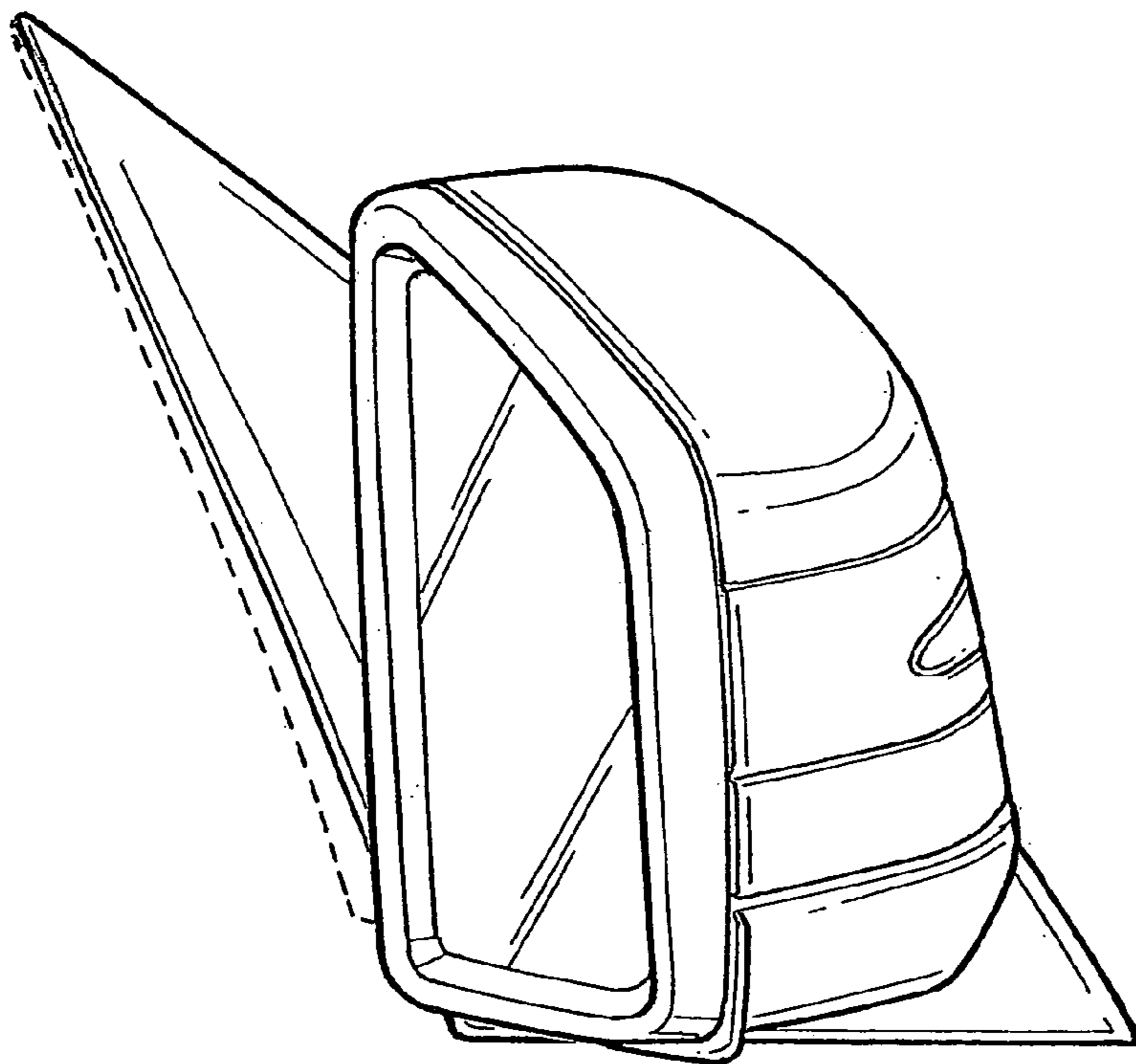

FIG. 16

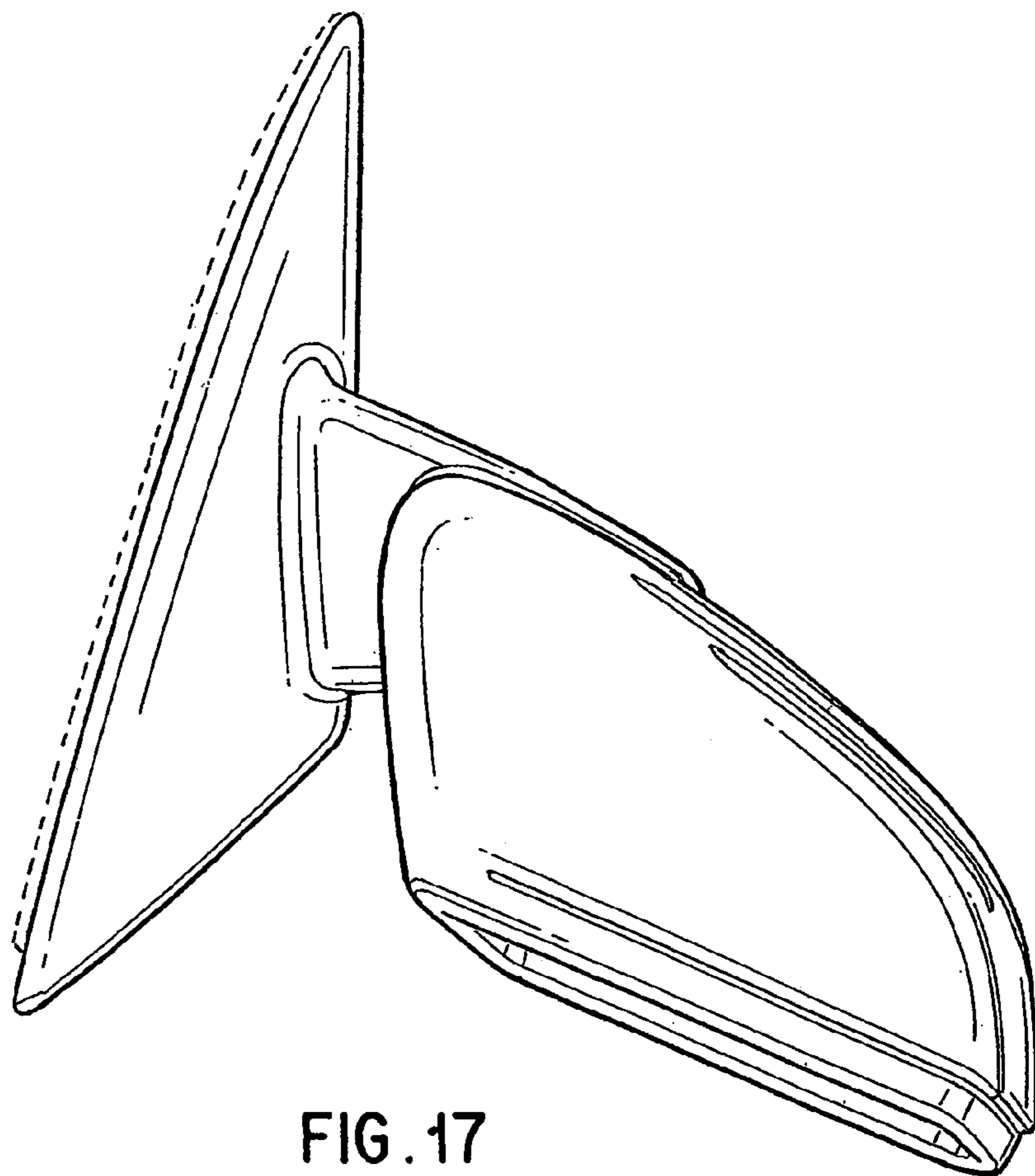

FIG. 17

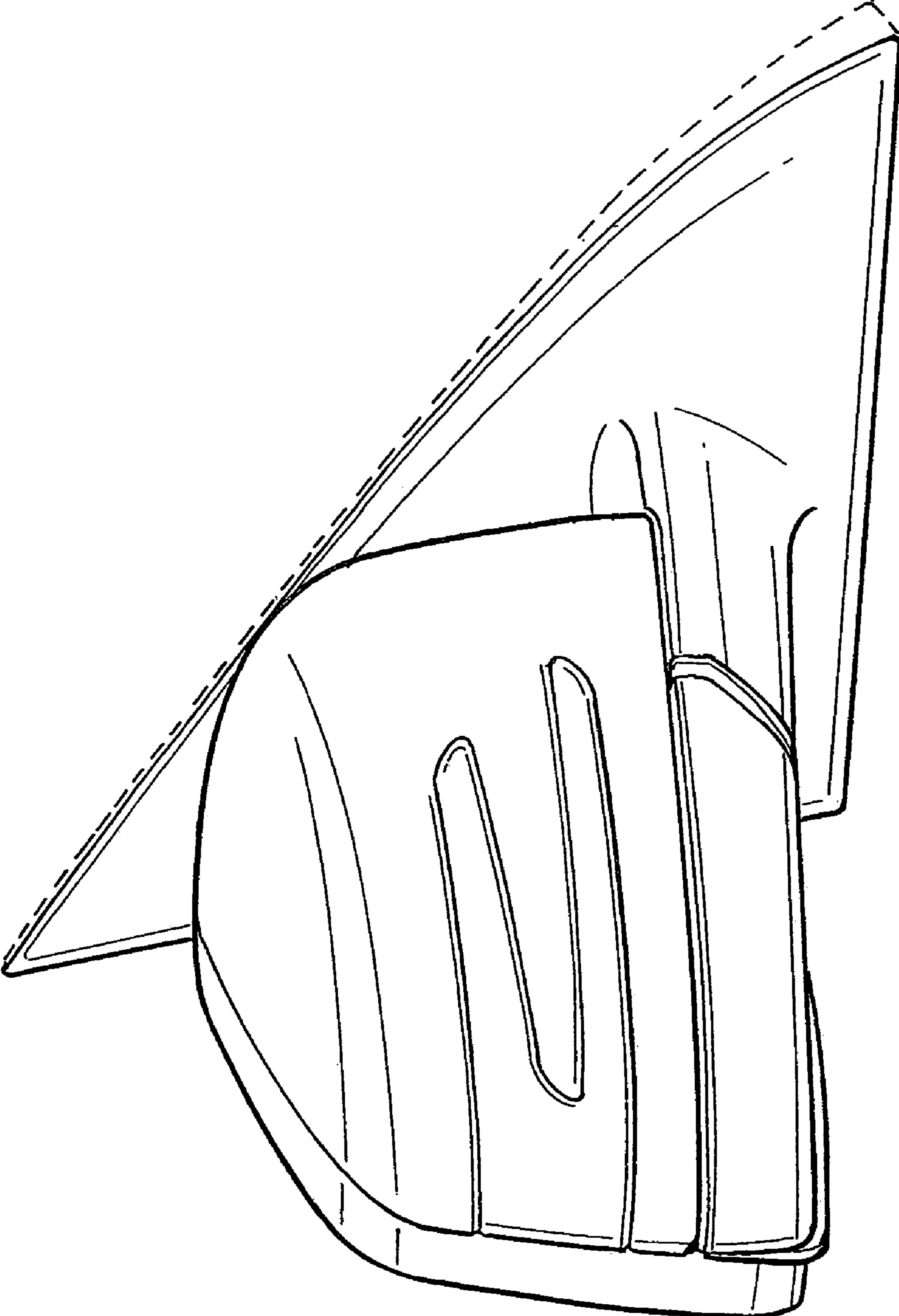

FIG. 18

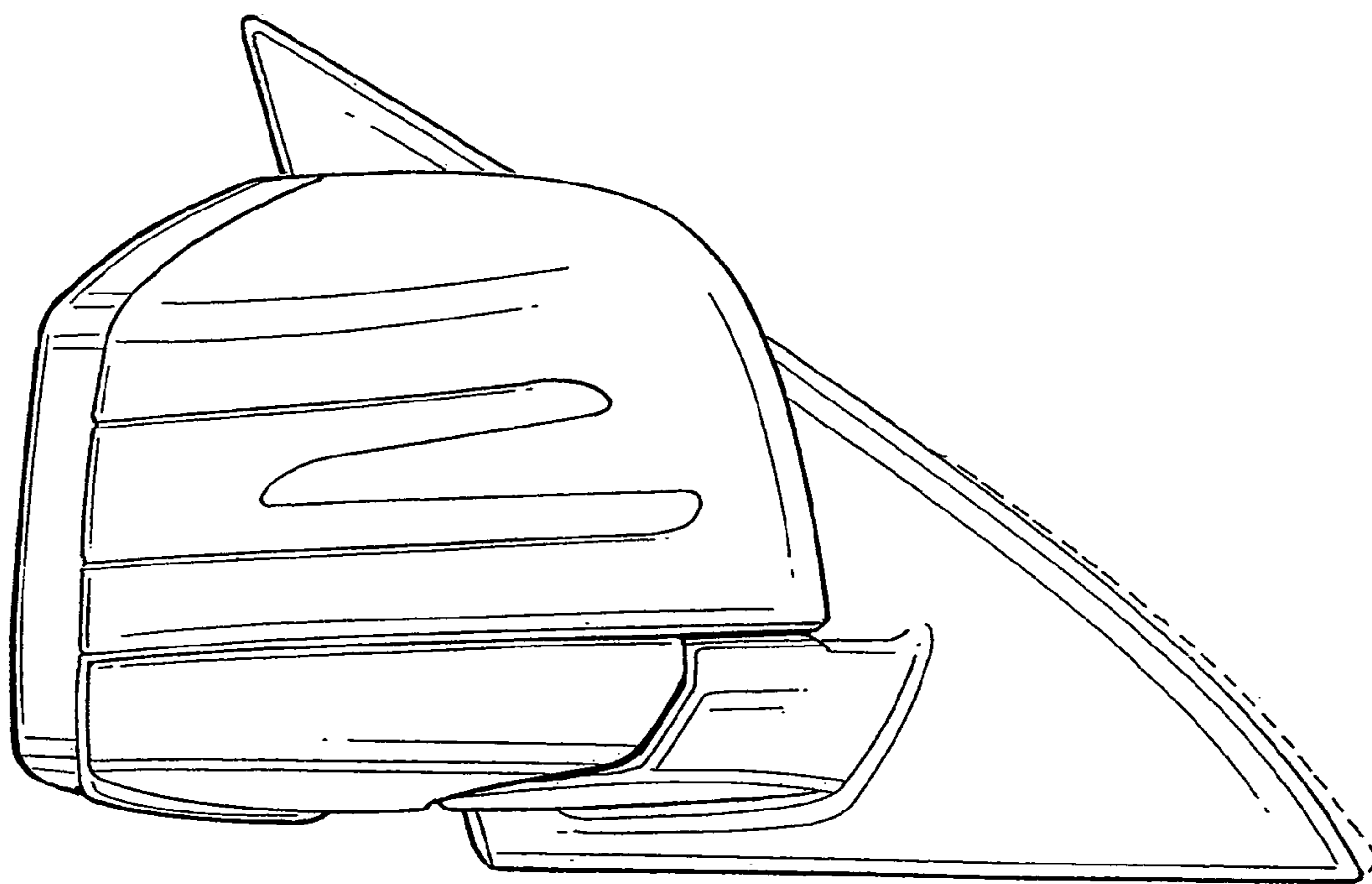

FIG. 19

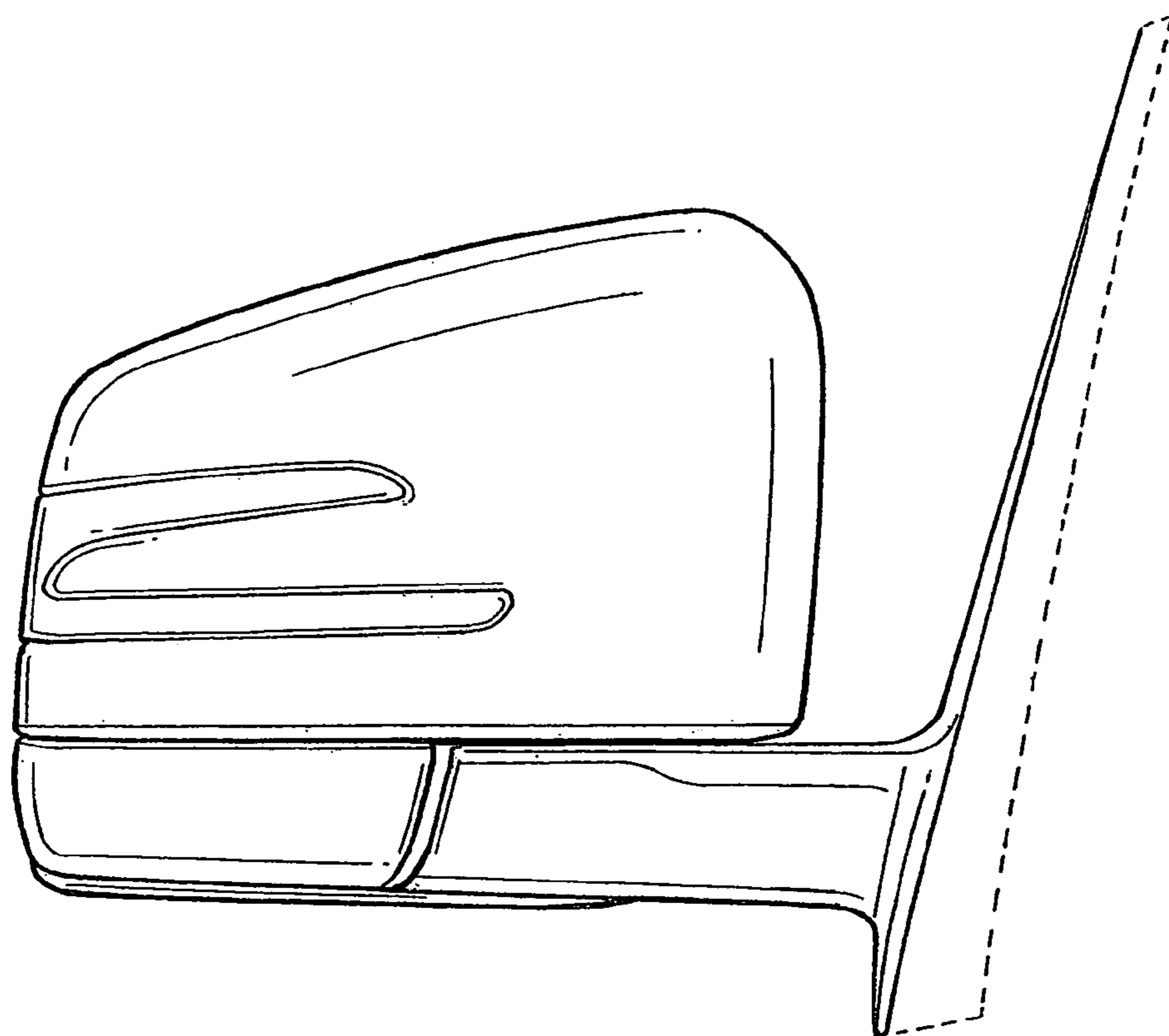

FIG. 20

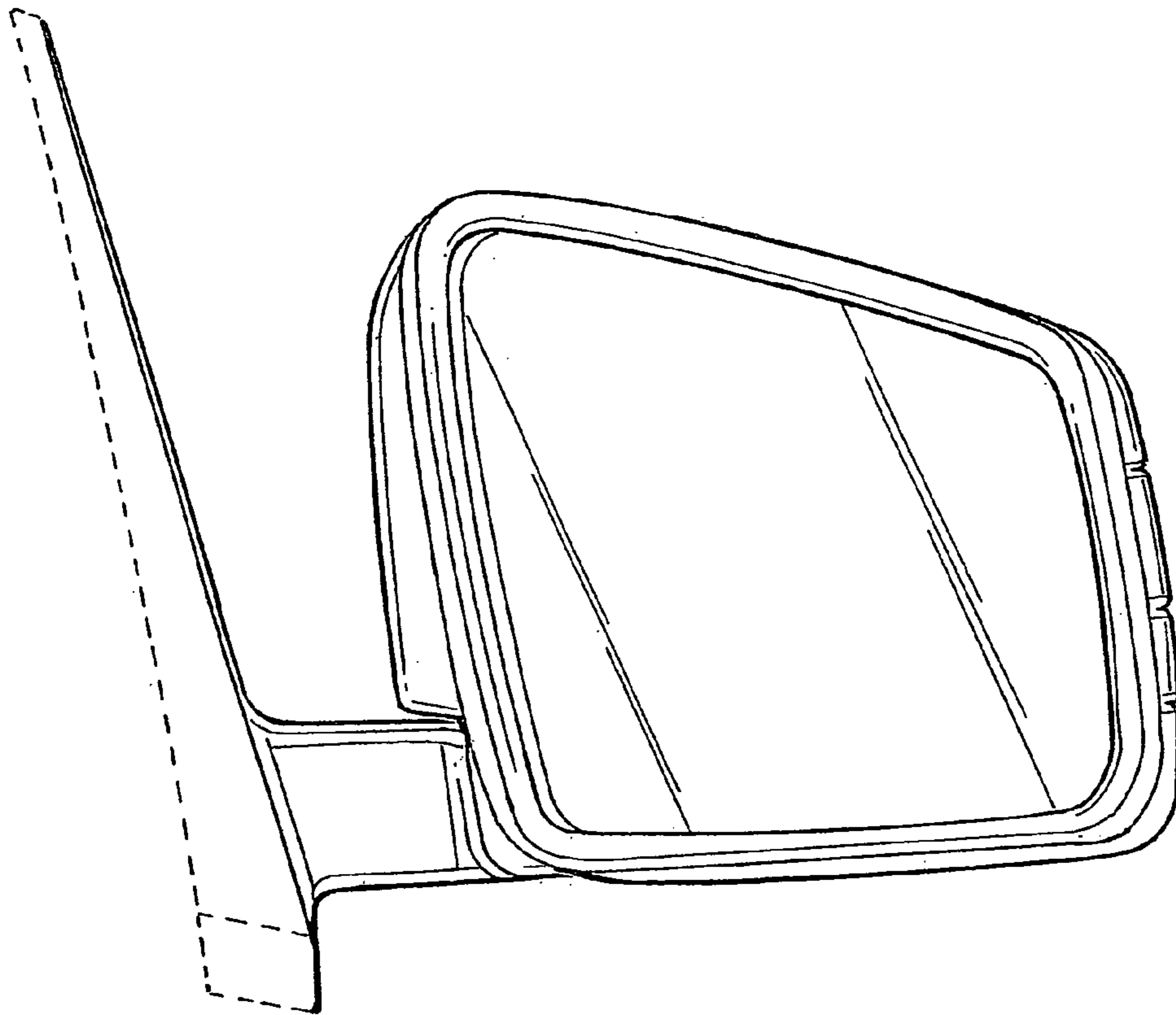

FIG. 21

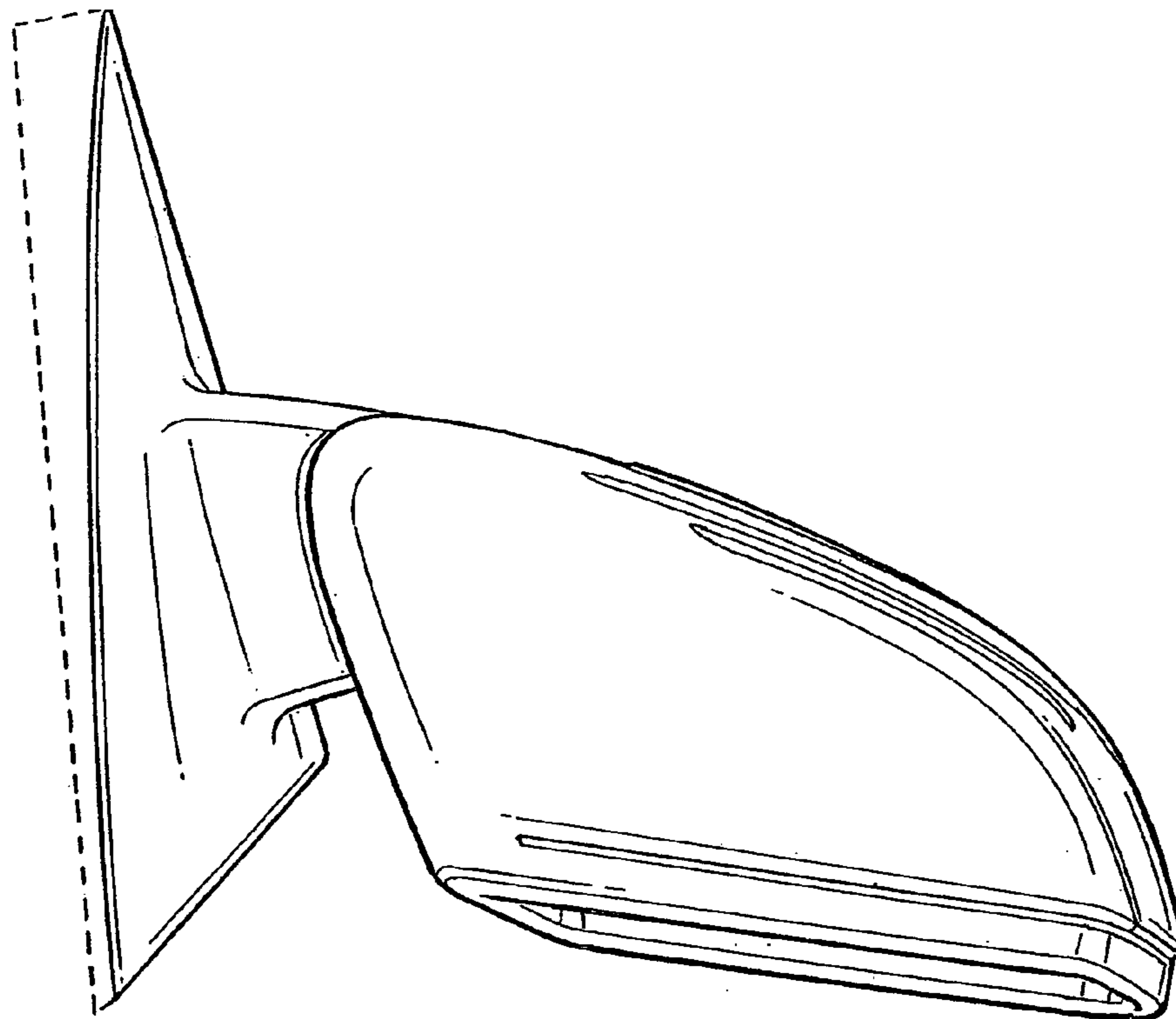

FIG. 22