



US00D616173S

(12) **United States Design Patent**  
**Tuncel**

(10) **Patent No.:** **US D616,173 S**

(45) **Date of Patent:** **\*\* May 18, 2010**

(54) **LUGGAGE CART**

D550,920 S \* 9/2007 Tuncel ..... D34/17  
D591,473 S \* 4/2009 Tuncel ..... D34/17

(75) Inventor: **Levent Tuncel**, Atlanta, GA (US)

\* cited by examiner

(73) Assignee: **Levent Industries, Inc.**, Atlanta, GA (US)

*Primary Examiner*—Cynthia E Ramirez

(74) *Attorney, Agent, or Firm*—George R. Reardon

(\*\*) Term: **14 Years**

(57) **CLAIM**

(21) Appl. No.: **29/335,257**

The ornamental design for a luggage cart, as shown.

(22) Filed: **Apr. 11, 2009**

**DESCRIPTION**

(51) **LOC (9) Cl.** ..... **12-02**

FIG. 1 is a perspective view of a luggage cart, showing my new design;

(52) **U.S. Cl.** ..... **D34/17**

FIG. 2 is a right side elevational view thereof;

(58) **Field of Classification Search** ..... D34/12-27;  
280/79.3, 33.998, 47.34, 47.35, 47.36; D6/475,  
D6/410; 211/204

FIG. 3 is a front elevational view thereof;

FIG. 4 is a top plan view thereof;

See application file for complete search history.

FIG. 5 is a bottom plan view thereof; and,

FIG. 6 is a perspective view thereof showing an enlarged top perspective view, bottom perspective view, and side view of the encircled top element for clarity.

(56) **References Cited**

**U.S. PATENT DOCUMENTS**

D239,094 S	3/1976	Duffy	
D324,283 S	2/1992	DeWitt	
D329,727 S	9/1992	DeWitt	
5,190,305 A *	3/1993	Putman	..... 280/79.3
D341,689 S	11/1993	Putman et al.	
D341,690 S	11/1993	Putman et al.	
D550,919 S *	9/2007	Tuncel	..... D34/17

The broken line showing of the wheels and elements on the bottom of the cart is included for the purpose of illustrating the environment and forms no part of the claimed design.

A portable cart used for transporting luggage and the like.

**1 Claim, 6 Drawing Sheets**

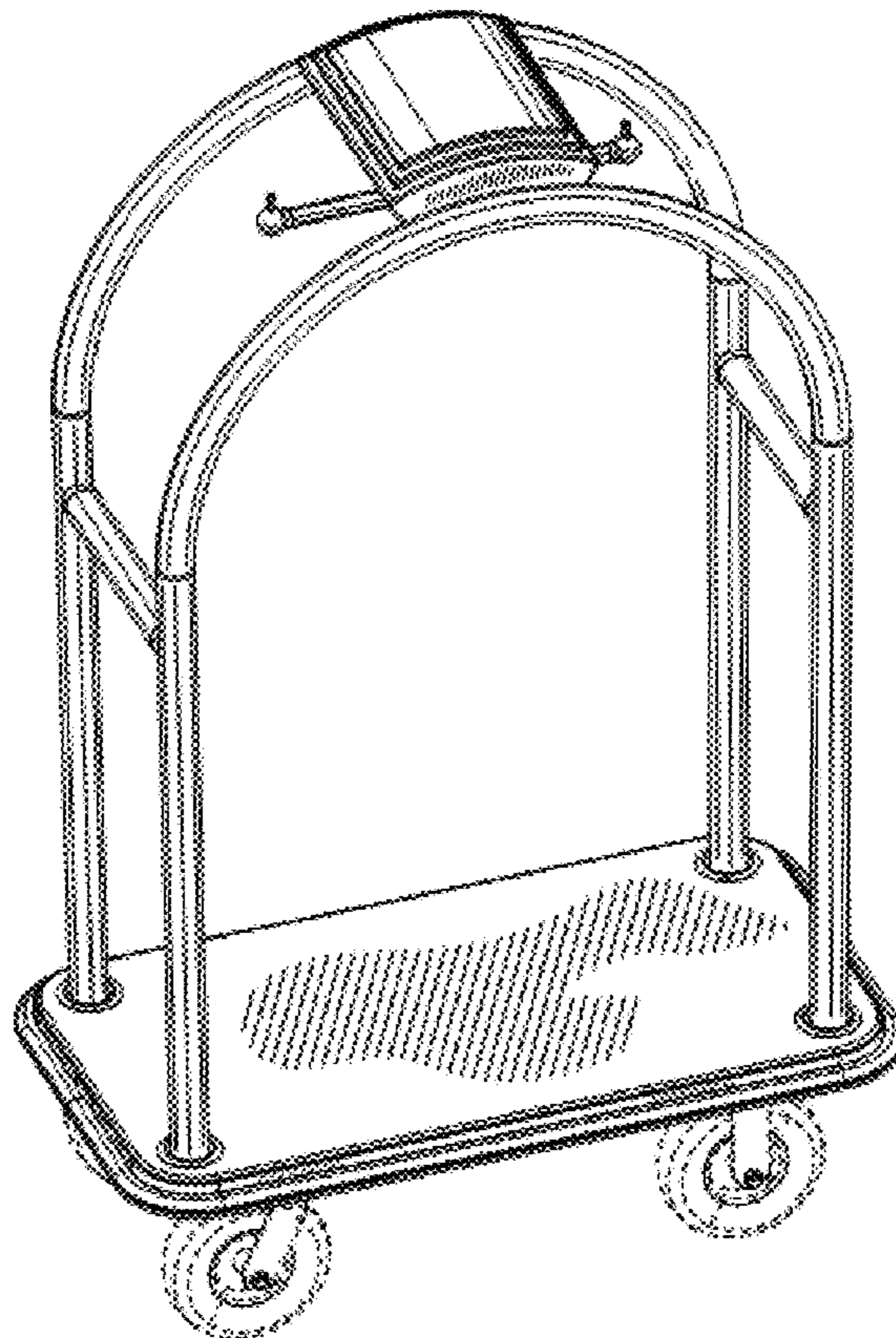

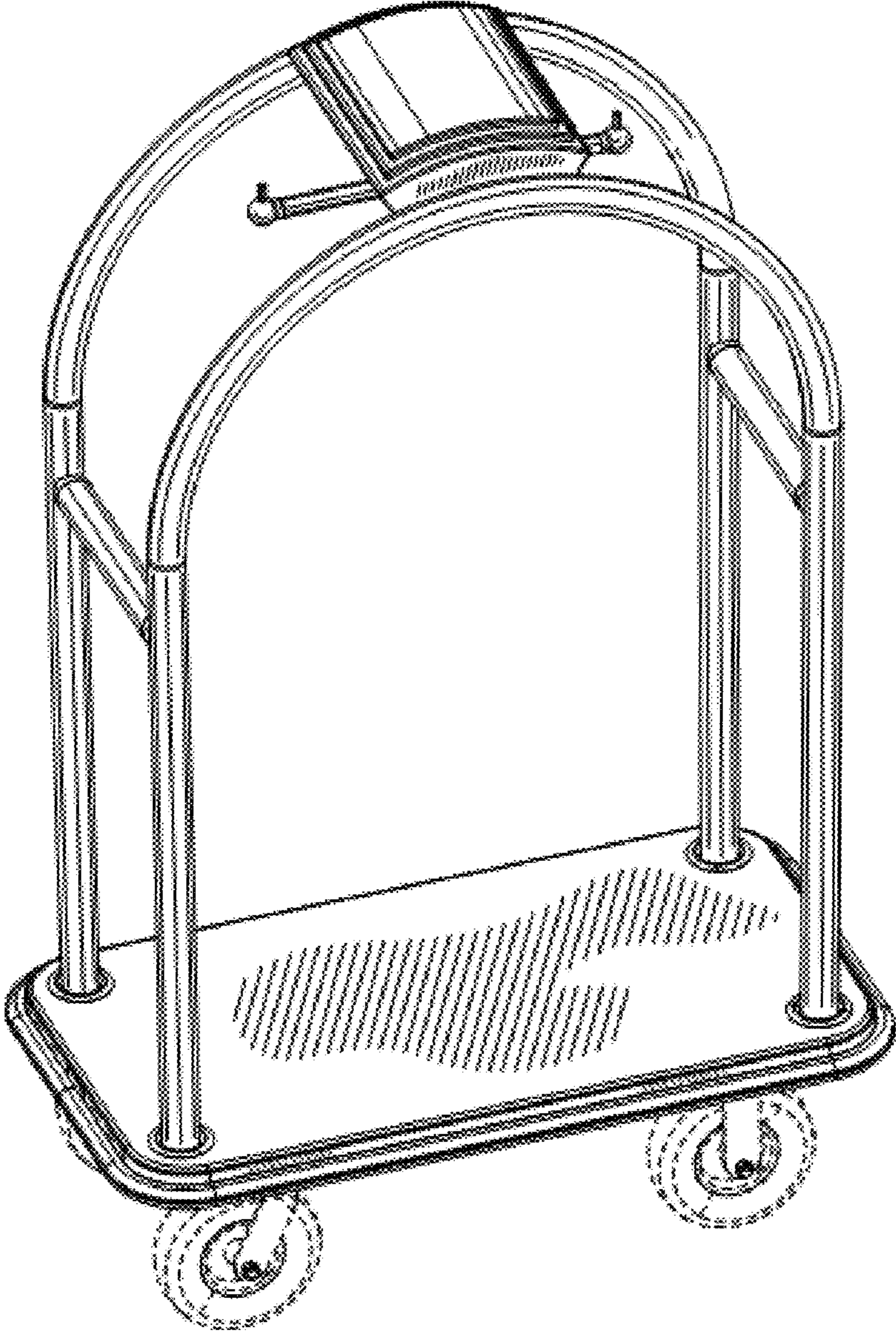
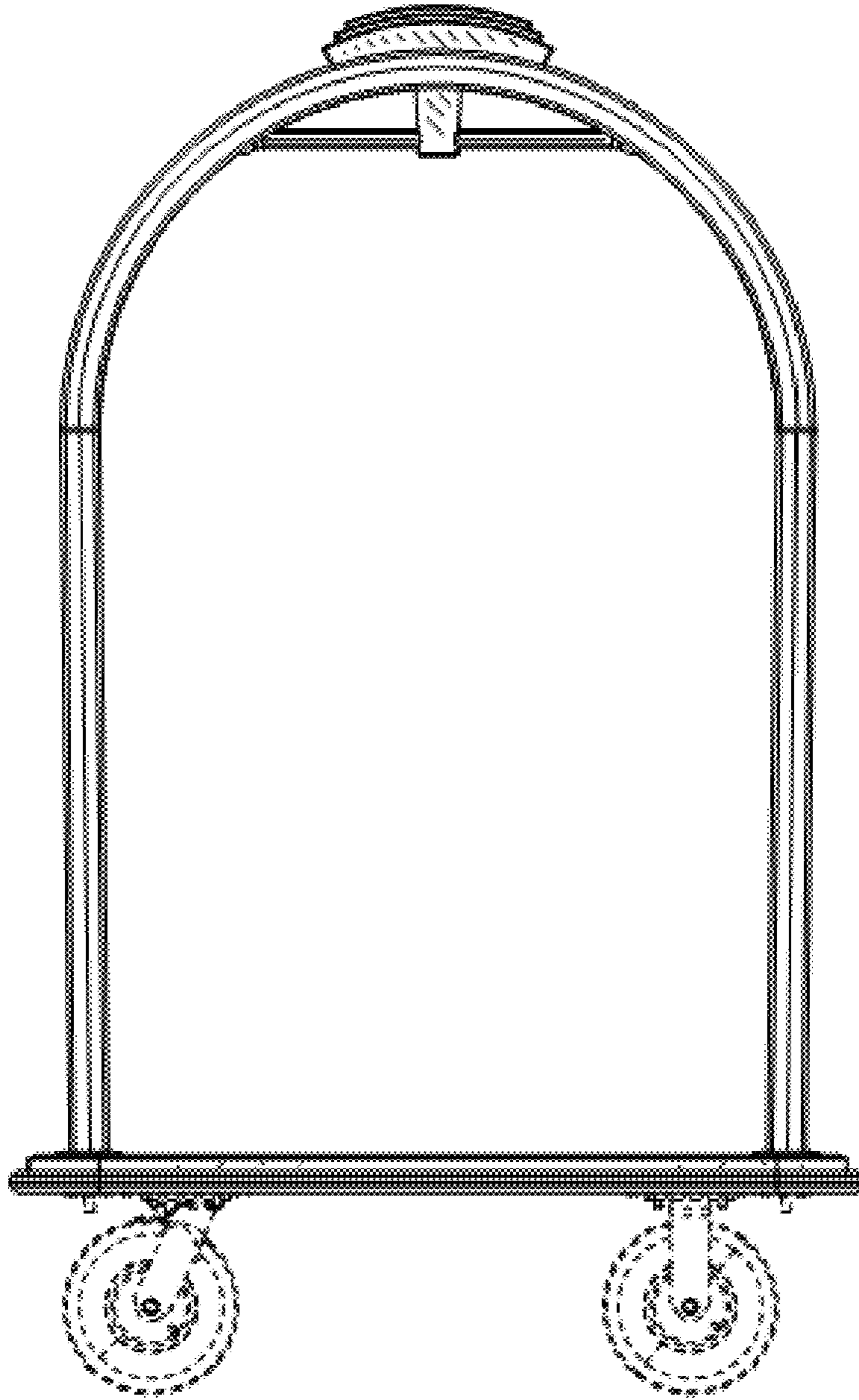
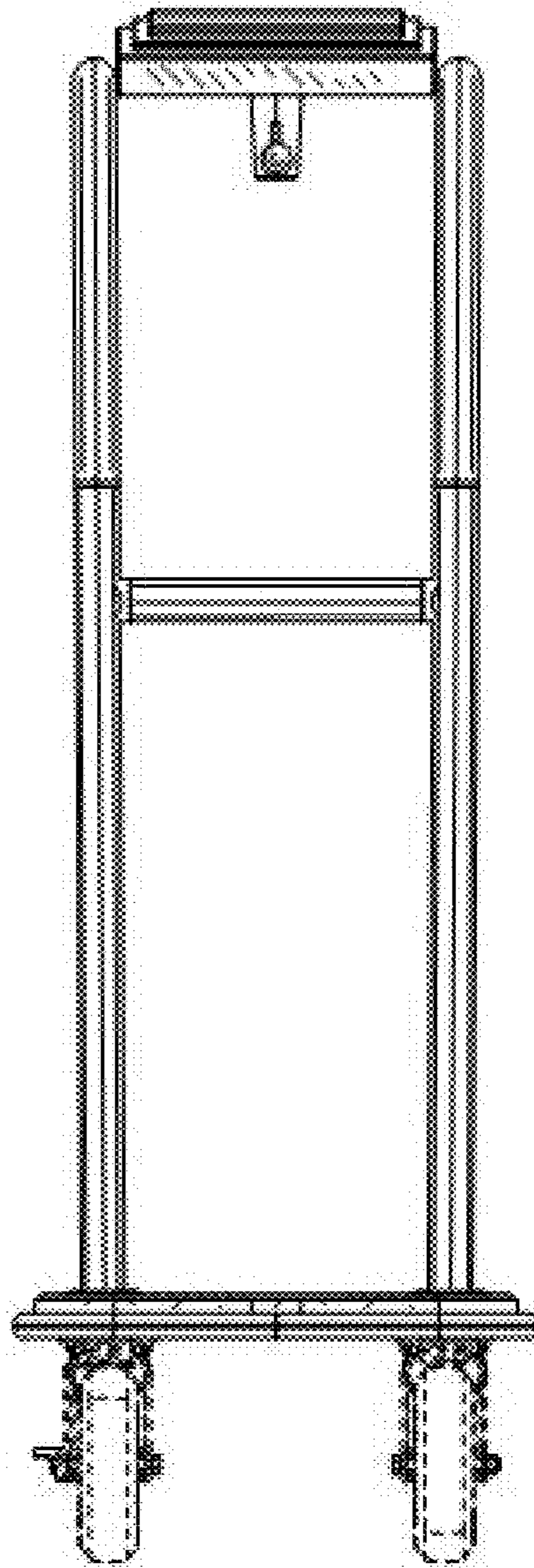

FIG. 1



**FIG. 2**



**FIG. 3**

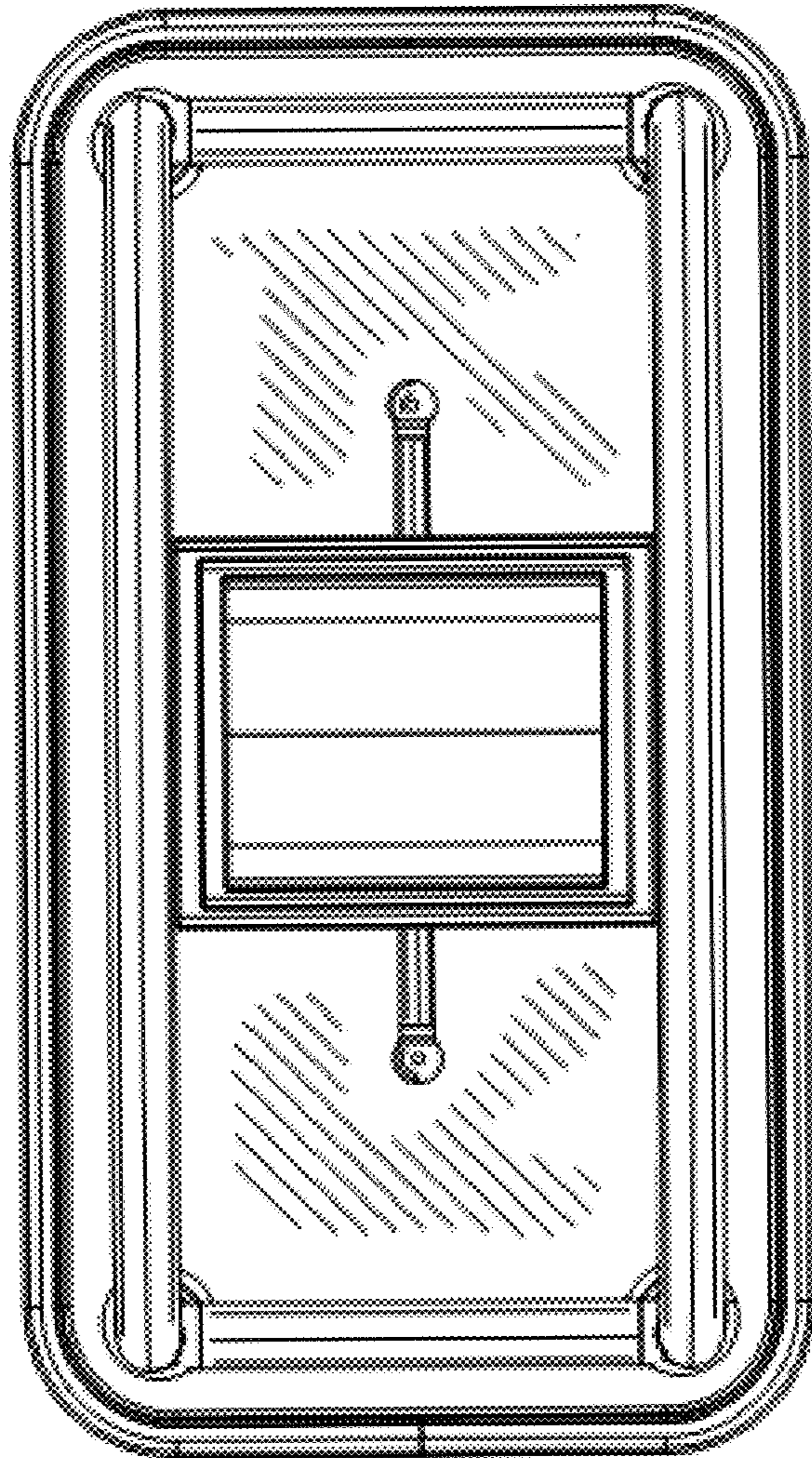

**FIG. 4**

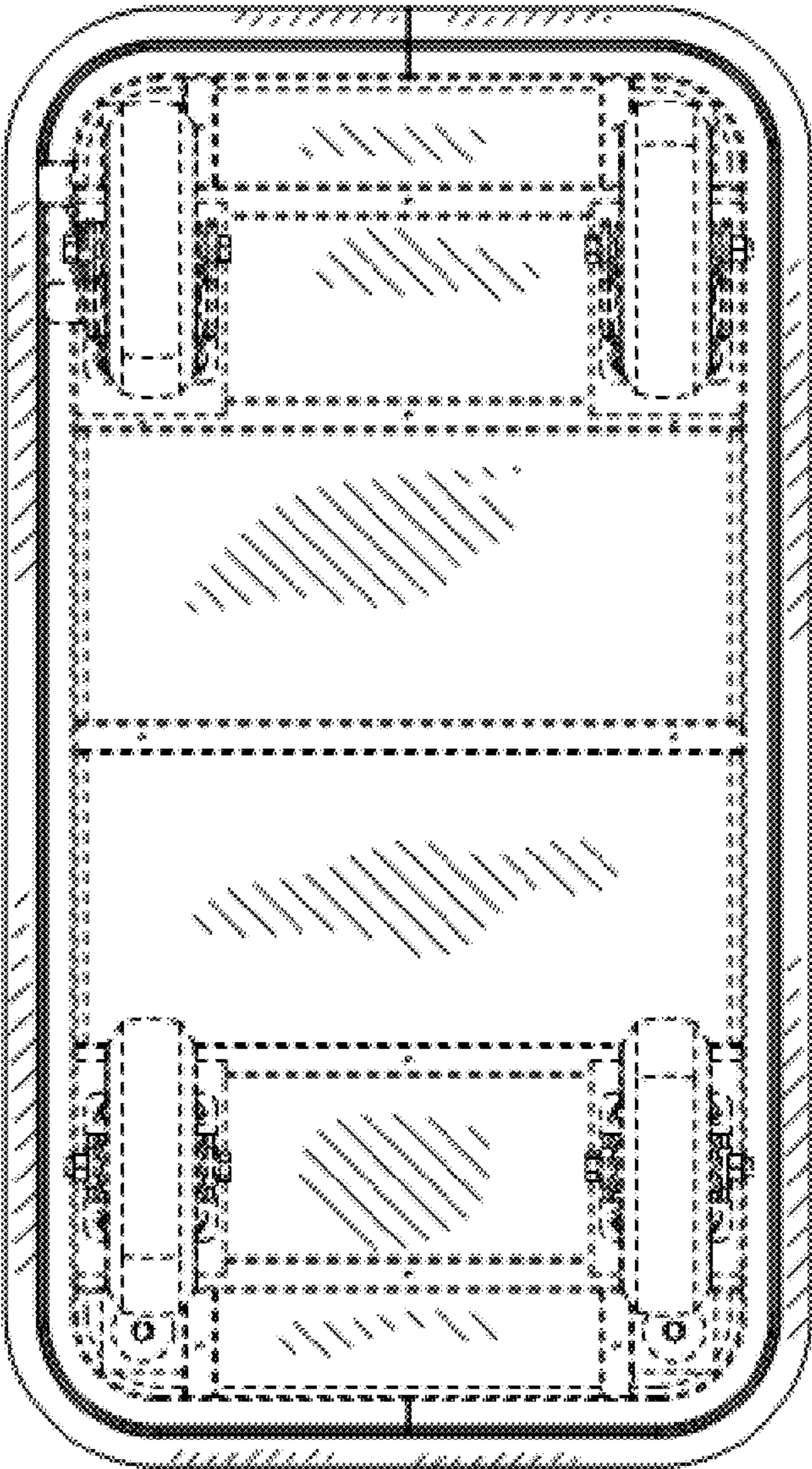

**FIG. 5**

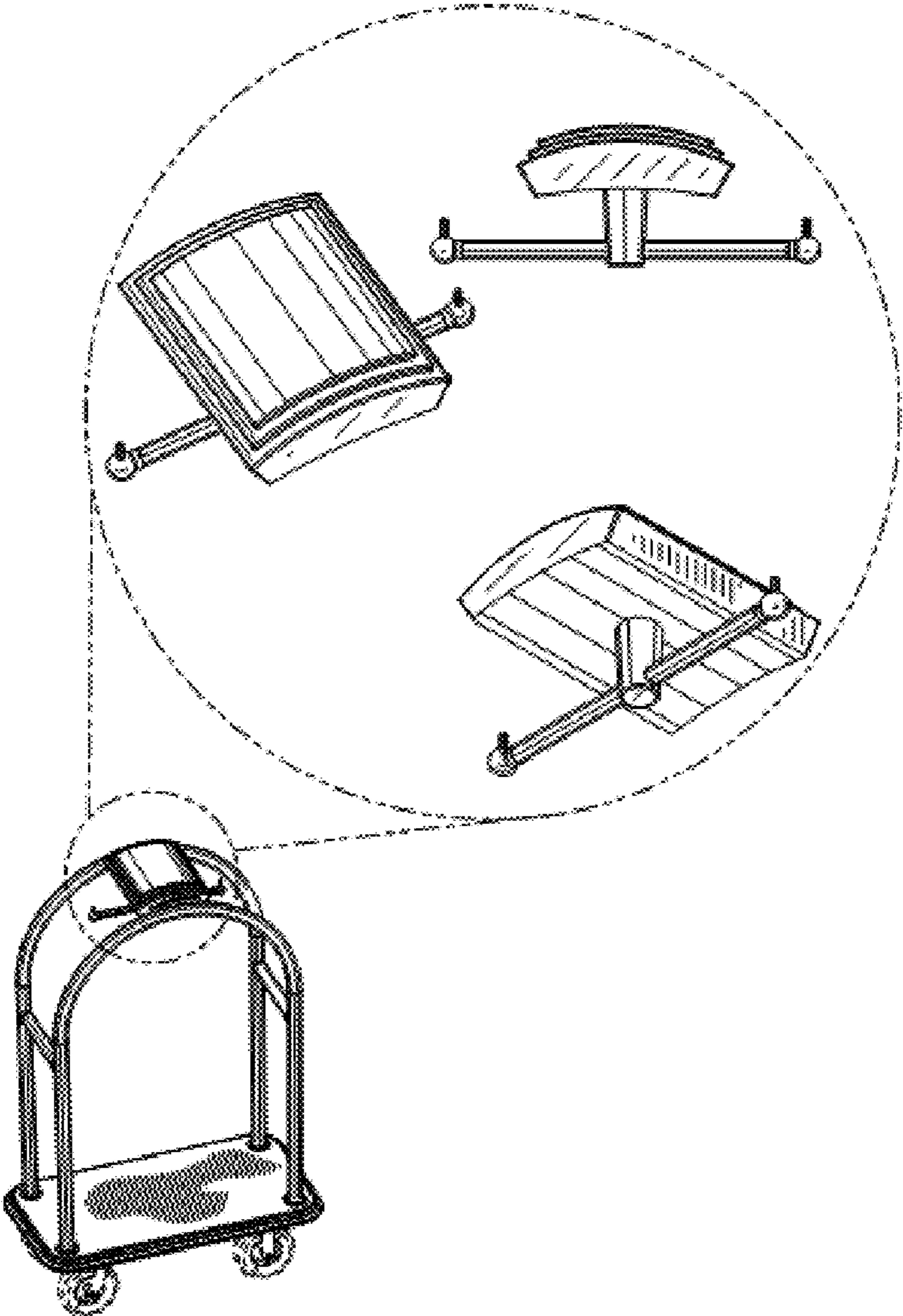

FIG. 6