



US00D616078S

(12) **United States Design Patent**
Prescott

(10) **Patent No.:** **US D616,078 S**

(45) **Date of Patent:** **** May 18, 2010**

(54) **AIRCRAFT DESIGN**

(76) Inventor: **James E. Prescott**, 13 Riverwood Rd.,
Kingston, NH (US) 03848

(**) Term: **14 Years**

(21) Appl. No.: **29/325,786**

(22) Filed: **Oct. 6, 2008**

(51) **LOC (9) Cl.** **12-07**

(52) **U.S. Cl.** **D23/319**

(58) **Field of Classification Search** D12/319,
D12/320, 335, 338, 341-345; 244/12.1,
244/12.3, 13, 15, 207, 213, 45 A, 45 R
See application file for complete search history.

(56) **References Cited**

U.S. PATENT DOCUMENTS

4,741,497	A *	5/1988	Fox	244/117 R
5,433,400	A *	7/1995	Singhal et al.	244/12.1
D500,008	S *	12/2004	Bulaga	D12/345
D524,227	S *	7/2006	Stille et al.	D12/327
D533,604	S *	12/2006	Butler et al.	D21/447
D583,294	S *	12/2008	Balaskovic	D12/319

* cited by examiner

Primary Examiner—Cathron C. Brooks

Assistant Examiner—Maurice Stevens

(74) *Attorney, Agent, or Firm*—Hani Z. Sayed; Rutan &
Tucker, LLP

(57) **CLAIM**

The ornamental design for an aircraft design, as shown and described.

DESCRIPTION

FIG. 1 is a front, left side perspective view of the aircraft design in an embodiment of the present invention;

FIG. 2 is a side view of the aircraft design in an embodiment of the present invention;

FIG. 3 is a front view of the aircraft design in an embodiment of the present invention;

FIG. 4 is a top view of the aircraft design in an embodiment of the present invention; and,

FIG. 5 is a bottom view of the aircraft design in an embodiment of the present invention.

1 Claim, 3 Drawing Sheets

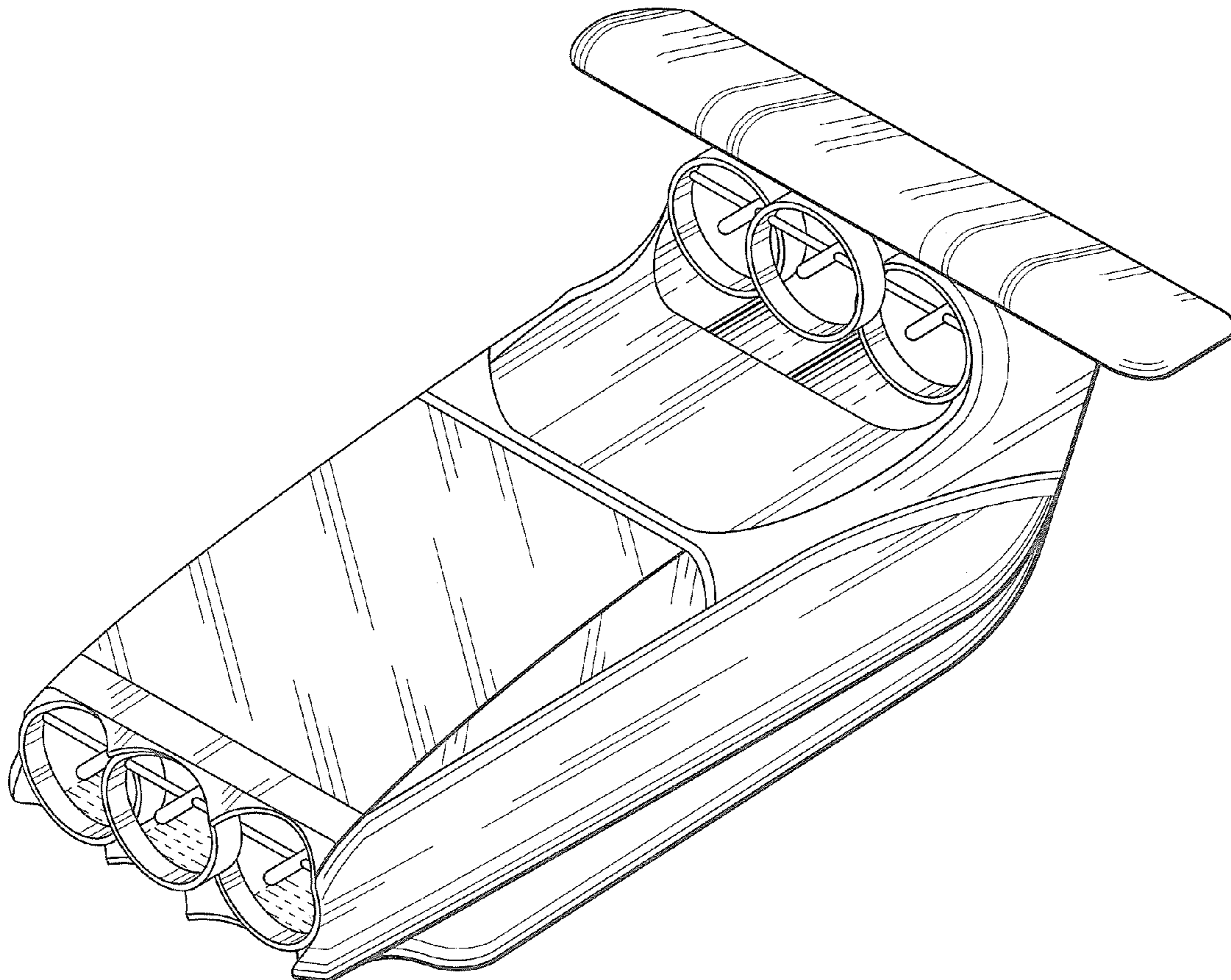

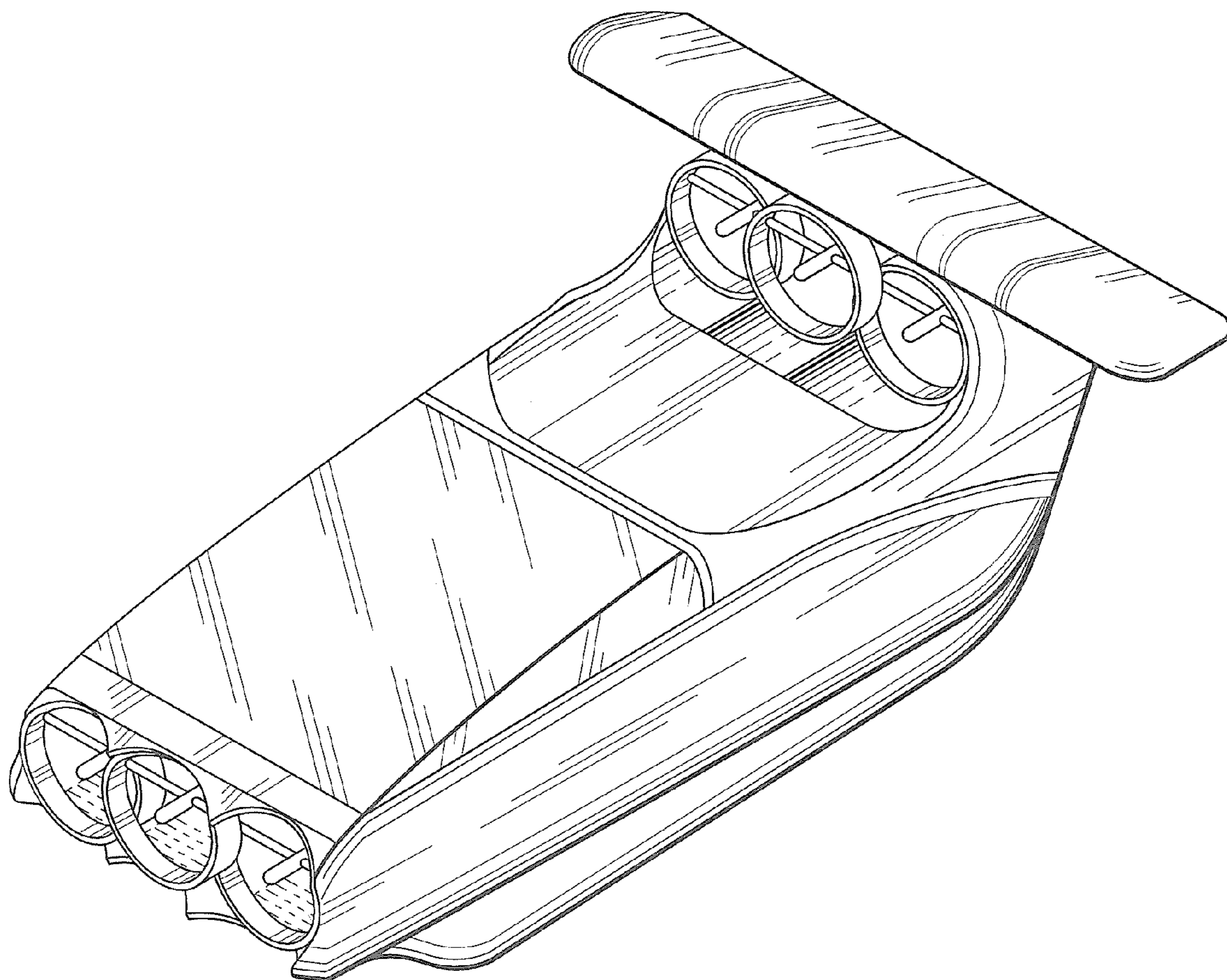

Figure 1

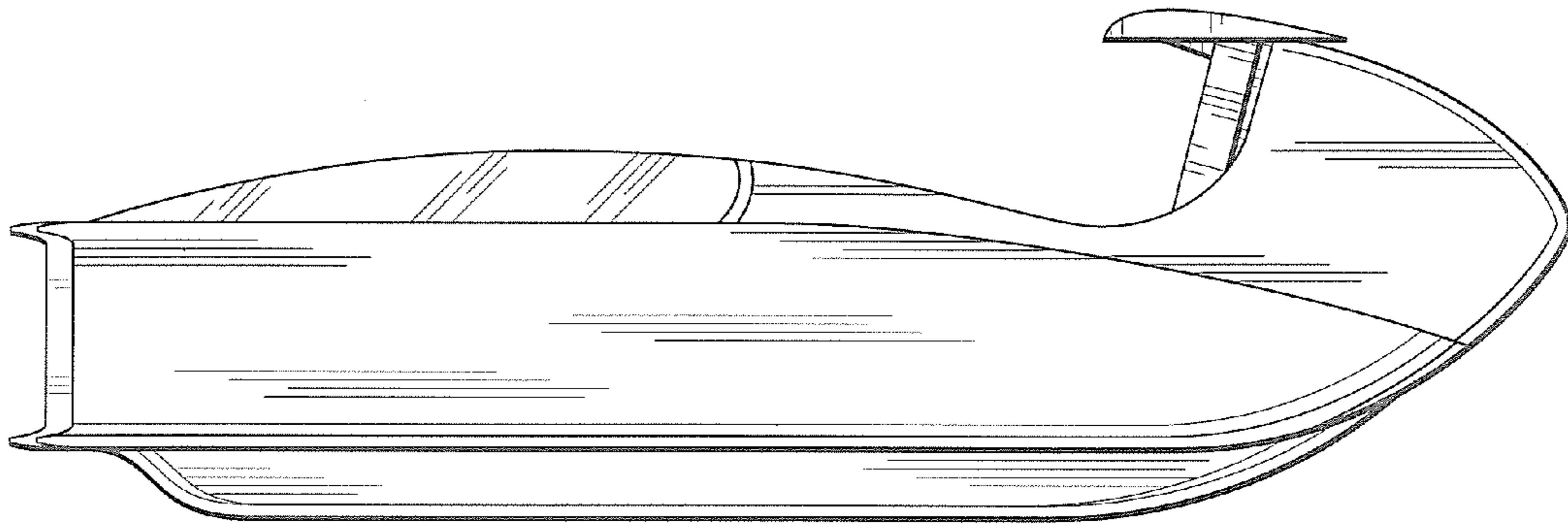

Figure 2

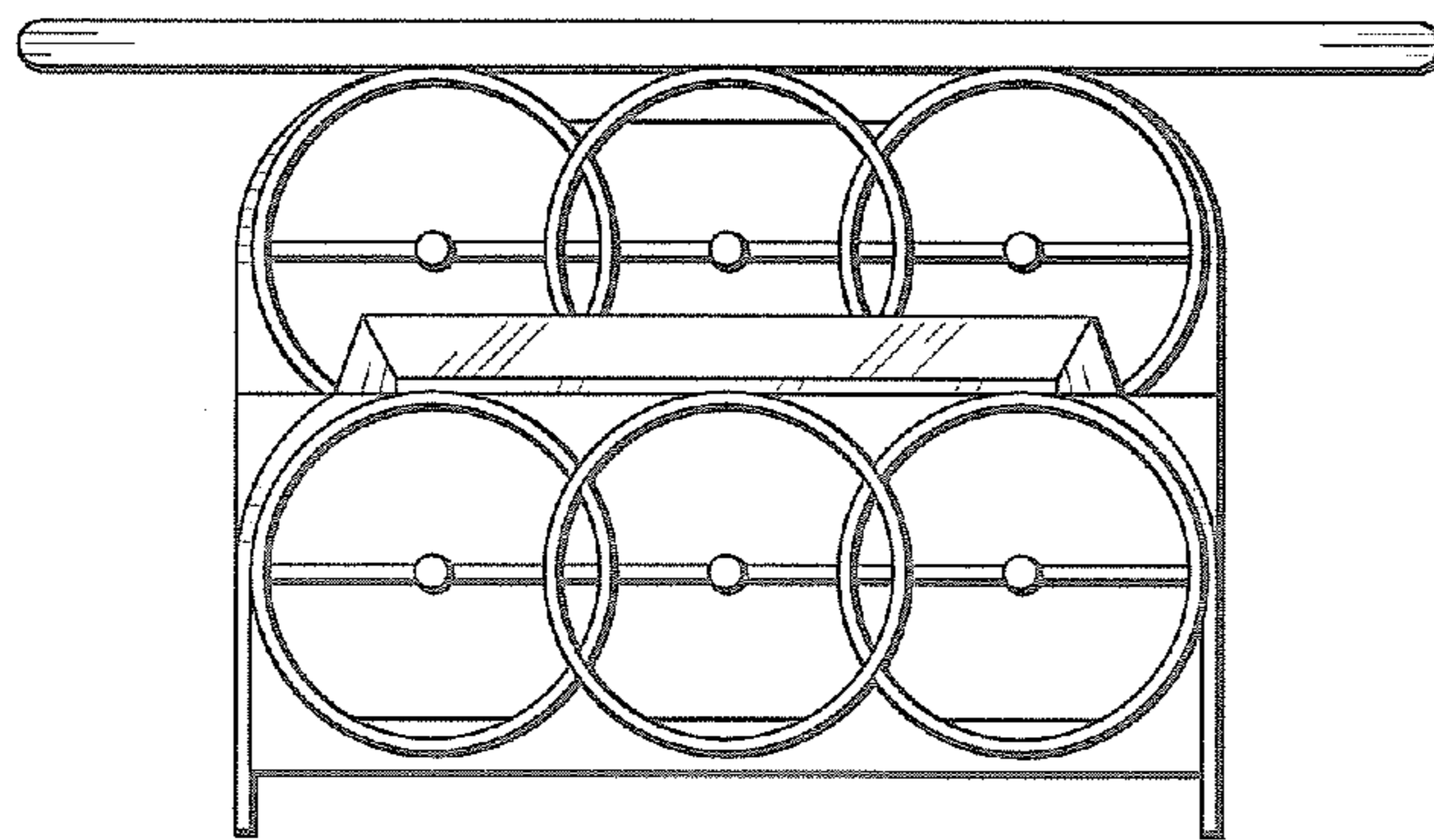

Figure 3

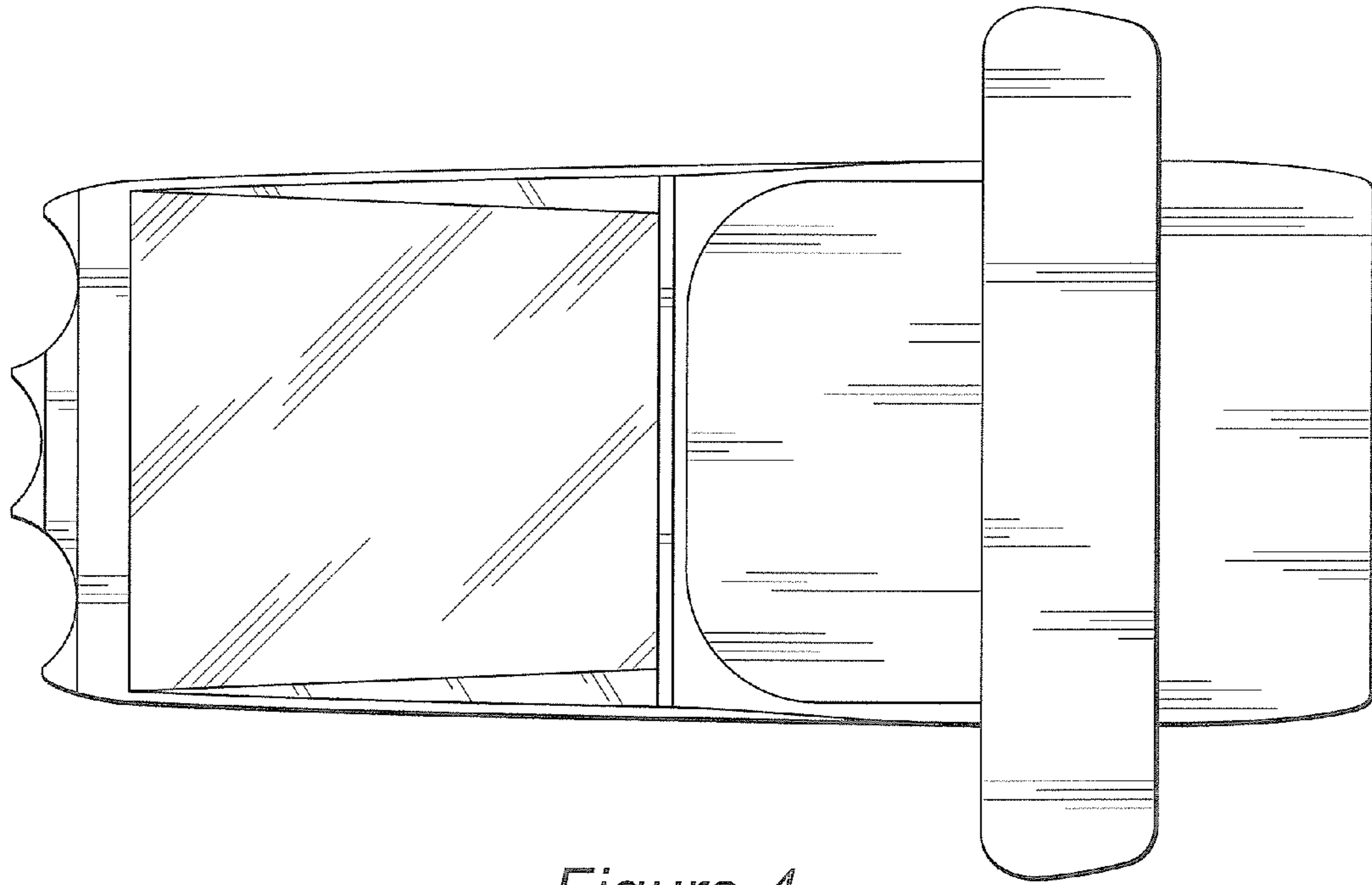

Figure 4

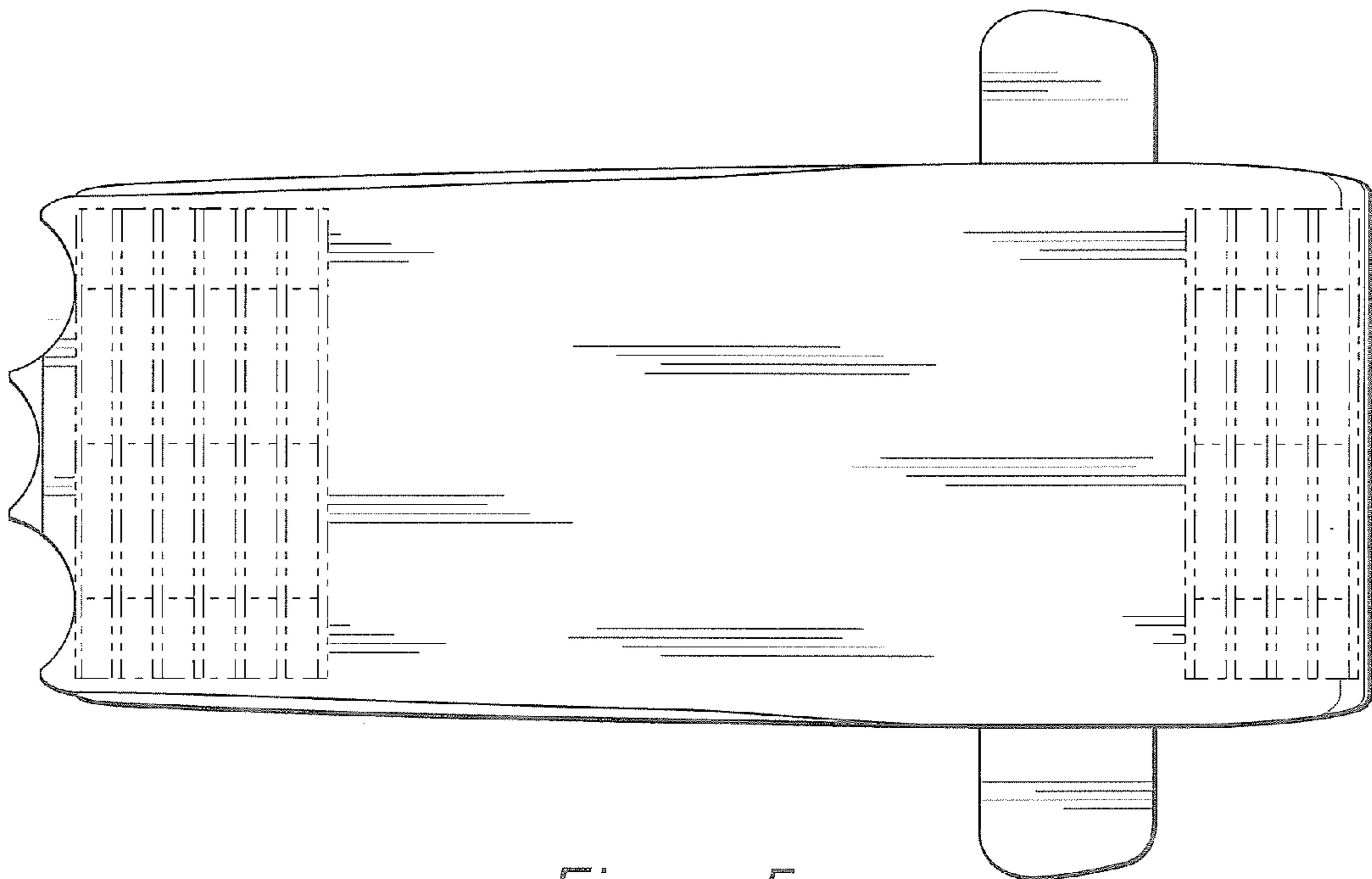

Figure 5