



US00D615906S

(12) **United States Design Patent**  
**Morrow**

(10) **Patent No.:** **US D615,906 S**

(45) **Date of Patent:** **\*\* May 18, 2010**

(54) **DOUBLE-SPROCKET BICYCLE FRAME**

(74) *Attorney, Agent, or Firm*—Frank G. Morkunas

(76) **Inventor:** **David D. Morrow**, 1344 Garnet Ave.,  
San Diego, CA (US) 92109

(57) **CLAIM**

(\*\*) **Term:** **14 Years**

I claim the ornamental design for the double-sprocket bicycle frame, as shown and described.

(21) **Appl. No.:** **29/333,628**

(22) **Filed:** **Mar. 12, 2009**

**DESCRIPTION**

(51) **LOC (9) Cl.** ..... **12-11**

FIG. 1 is a left side elevation view of a double-sprocket bicycle frame showing the new design.

(52) **U.S. Cl.** ..... **D12/111**

FIG. 2 is detailed close-up view of the spring associated with the double-sprocket bicycle frame.

(58) **Field of Classification Search** ..... D12/111,  
D12/117, 123; 280/274–278, 281.1, 288.1–288.3,  
280/283–288, 259–261

FIG. 3 is a right side elevation view of a bicycle frame showing the new design

See application file for complete search history.

FIG. 4 is top plan view of the double-sprocket bicycle frame.

(56) **References Cited**

FIG. 5 is a bottom plan view of the double-sprocket bicycle frame.

**U.S. PATENT DOCUMENTS**

D321,155 S *	10/1991	Tan	.....	D12/111
D348,859 S *	7/1994	Takagaki	.....	D12/111
D390,505 S *	2/1998	Shiau	.....	D12/111
D398,267 S *	9/1998	Yu et al.	.....	D12/111
D415,071 S *	10/1999	Lai	.....	D12/111
6,073,950 A *	6/2000	Busby	.....	280/284

FIG. 6 is a front elevation view of the double-sprocket bicycle frame; and,

FIG. 7 is rear elevation view of the double-sprocket bicycle frame.

\* cited by examiner

The broken lines illustrate portions of the bicycle frame which form no part of the claimed design.

*Primary Examiner*—Philip S Hyder  
*Assistant Examiner*—Linda G. Brooks

**1 Claim, 4 Drawing Sheets**

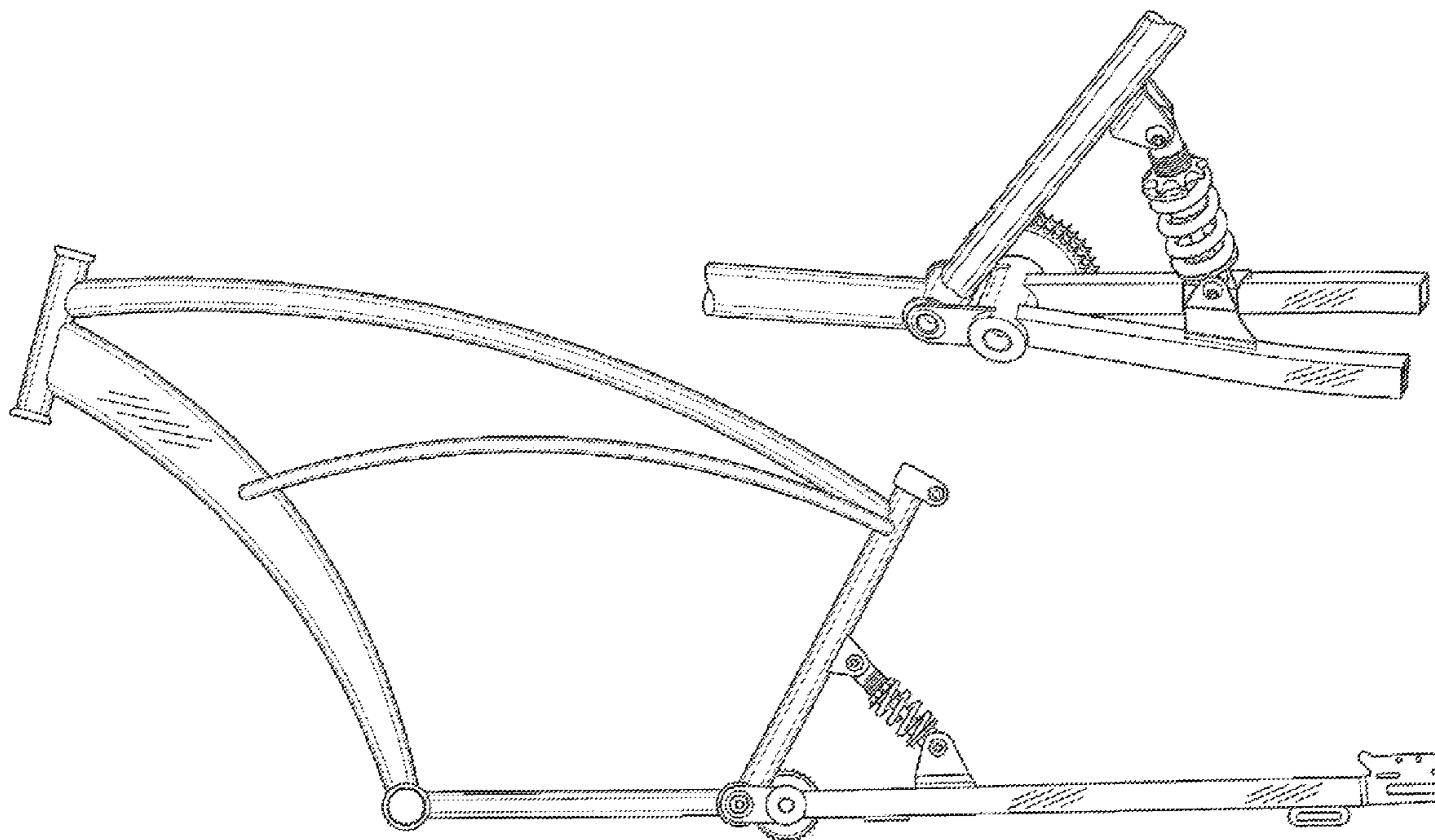

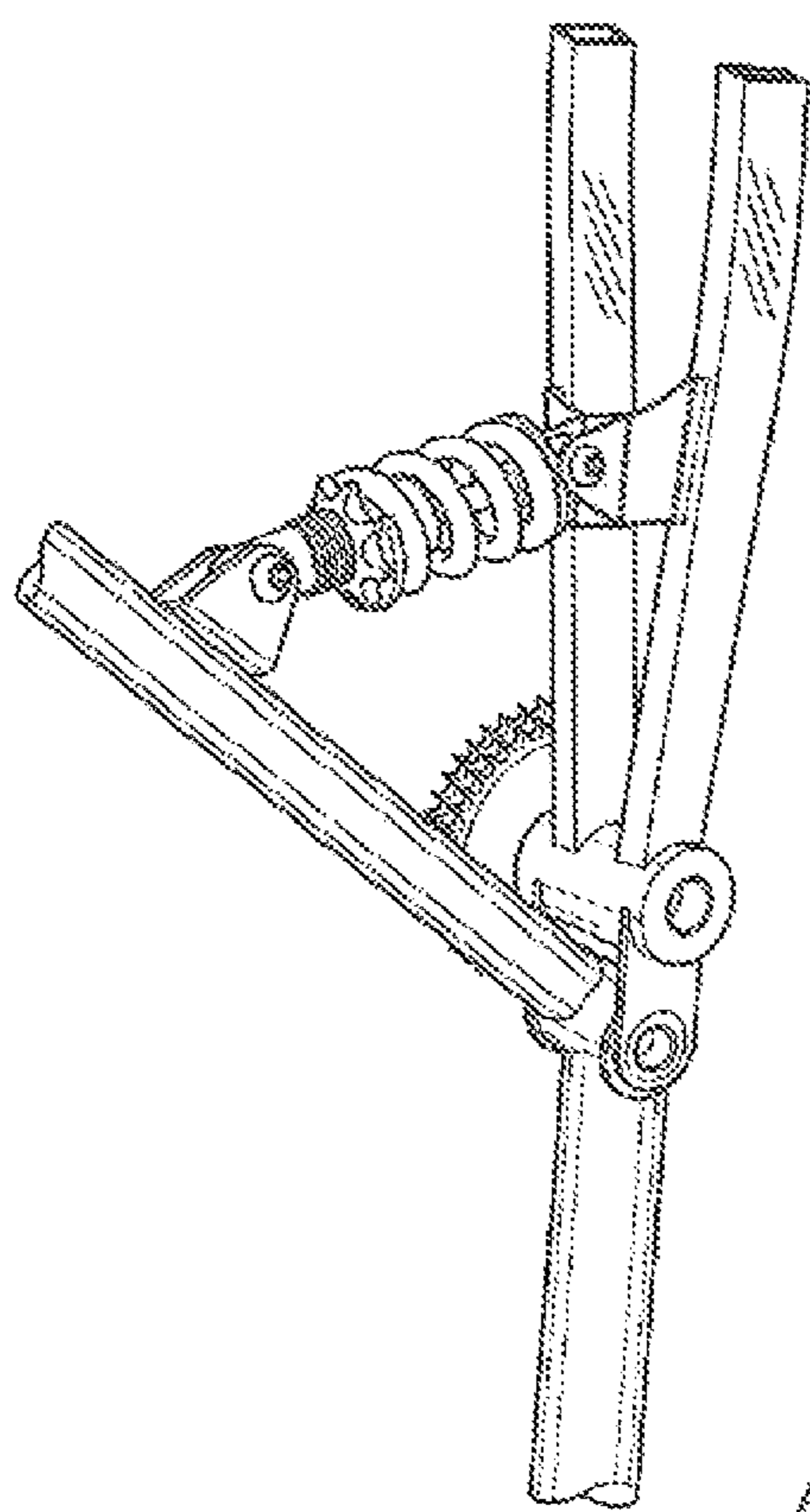

Fig. 2

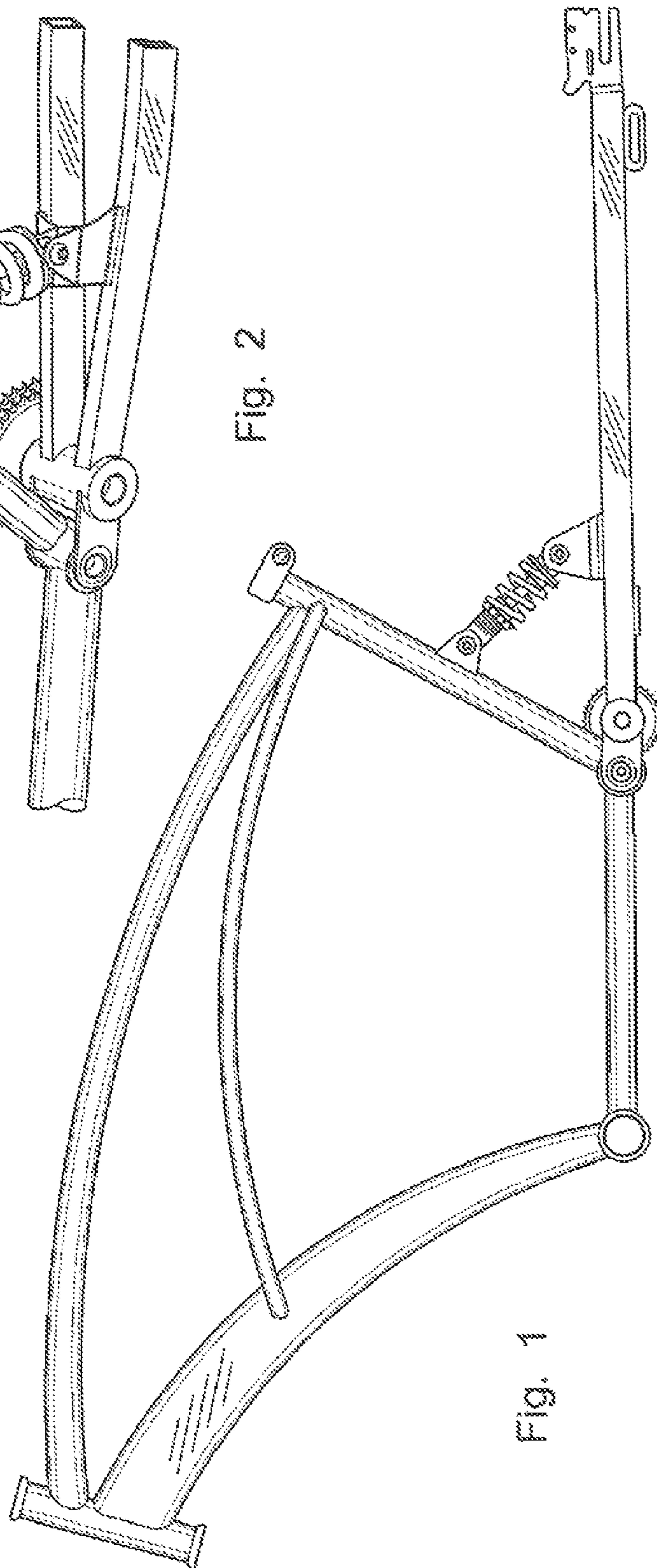
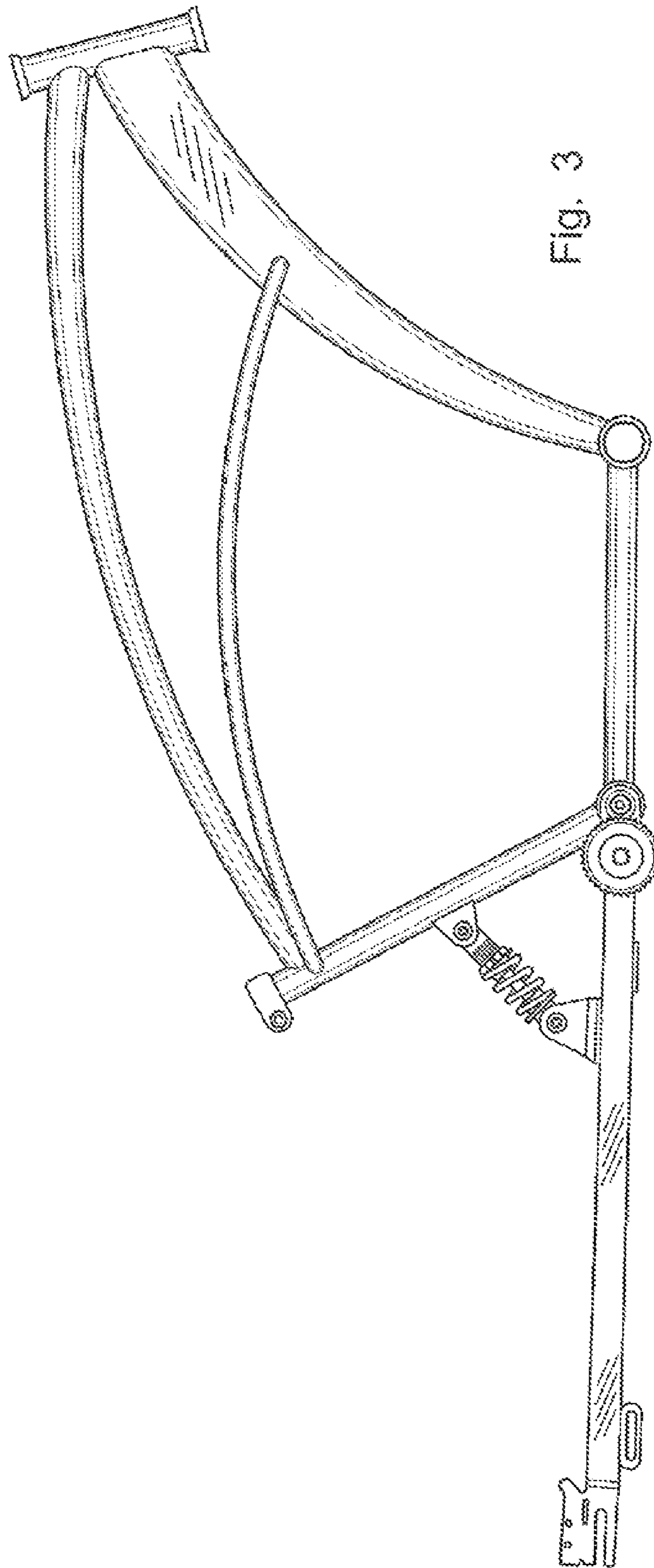

Fig. 1



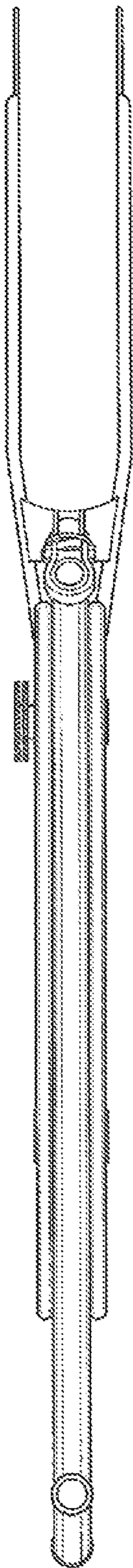

Fig. 4

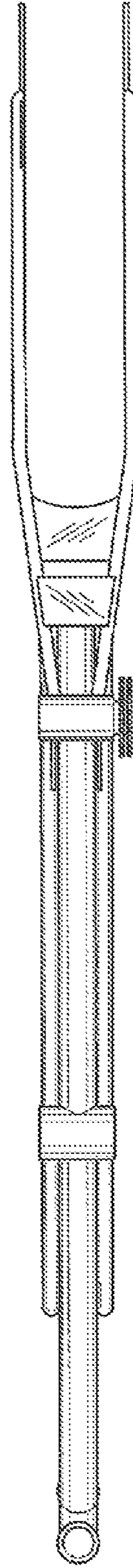

Fig. 5

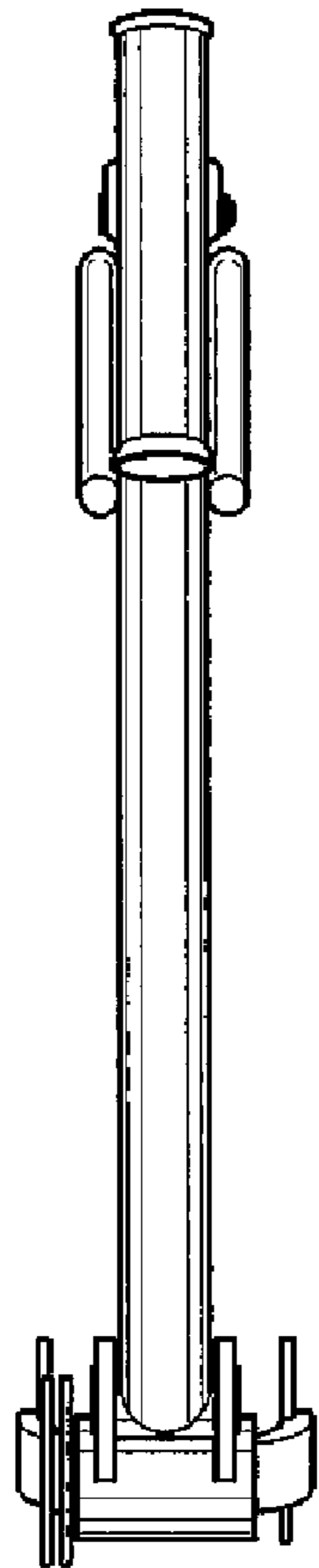

Fig. 6

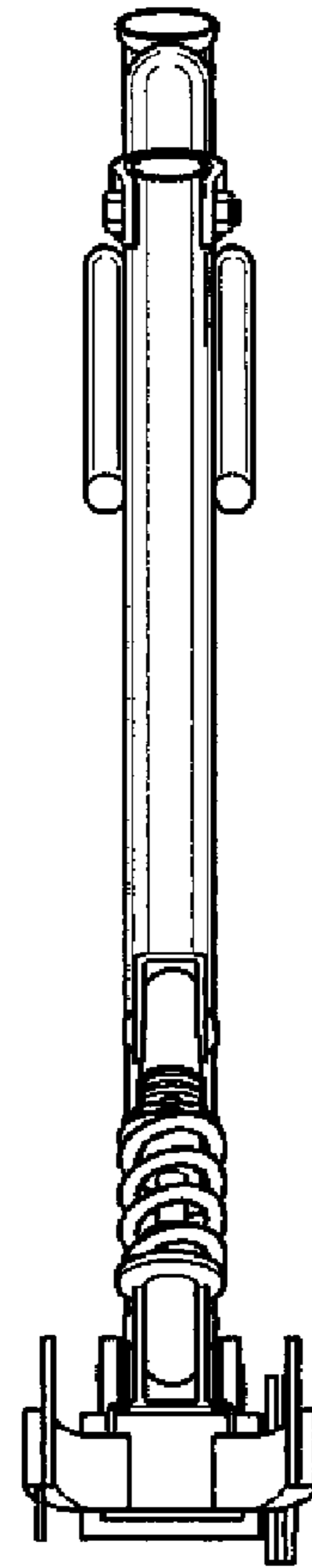

Fig. 7