



US00D615677S

(12) **United States Design Patent**  
**Feinbloom et al.**

(10) **Patent No.:** **US D615,677 S**  
(45) **Date of Patent:** **\*\* May 11, 2010**

(54) **ILLUMINATING HEADLAMP**

(75) Inventors: **Richard E. Feinbloom**, New York, NY (US); **Kenneth Braganca**, Ronkonkoma, NY (US)

(73) Assignee: **Designs for Vision, Inc.**, Ronkonkoma, NY (US)

(\*\*) Term: **14 Years**

(21) Appl. No.: **29/310,080**

(22) Filed: **Jul. 24, 2008**

**Related U.S. Application Data**

(62) Division of application No. 29/292,604, filed on Oct. 18, 2007, now Pat. No. Des. 582,085.

(51) **LOC (9) Cl.** ..... **26-02**

(52) **U.S. Cl.** ..... **D26/39**

(58) **Field of Classification Search** ..... D26/34, D26/37, 39, 51, 113, 120; D24/137, 150; D16/311, 133, 136; D29/103; D2/866, 875, D2/890-891; 362/103, 105-106, 253, 572, 362/804

See application file for complete search history.

(56) **References Cited**

**U.S. PATENT DOCUMENTS**

- D354,147 S \* 1/1995 Ueda ..... D26/28
- D383,229 S \* 9/1997 Kiichiro ..... D26/39
- D398,403 S \* 9/1998 Bishop et al. .... D24/231
- D399,580 S 10/1998 Feinbloom
- D441,886 S 5/2001 Beck
- D527,137 S 8/2006 Urich

D582,085 S \* 12/2008 Feinbloom et al. .... D26/39

\* cited by examiner

*Primary Examiner*—Ian Simmons

*Assistant Examiner*—Dana L Sipos

(74) *Attorney, Agent, or Firm*—Plevy + Keene LLP

(57) **CLAIM**

We claim, the ornamental design for a illuminating headlamp, as shown and described.

**DESCRIPTION**

FIG. 1 is an enlarged top, front, right side perspective view of the lamp portion of the design of FIG. 2 shown with the head strap removed;

FIG. 2 is a top, front, right side perspective view of an illuminated headlamp showing our new design;

FIG. 3 is a front elevational view thereof;

FIG. 4 is a rear elevational view thereof;

FIG. 5 is a right side elevational view thereof the left side elevation view thereof being a mirror image;

FIG. 6 is a top plan view thereof; and

FIG. 7 is a bottom plan view thereof;

FIG. 8 is a front elevational view of the headlamp portion of the design of FIG. 2 shown with the head strap removed;

FIG. 9 is a rear elevational view thereof;

FIG. 10 is a right side elevational view thereof, the left side elevational view being a mirror image;

FIG. 11 is a top plan view thereof; and,

FIG. 12 is a bottom plan view thereof.

The broken lines in the drawings illustrate portions of the design that form no part of the claim.

**1 Claim, 11 Drawing Sheets**

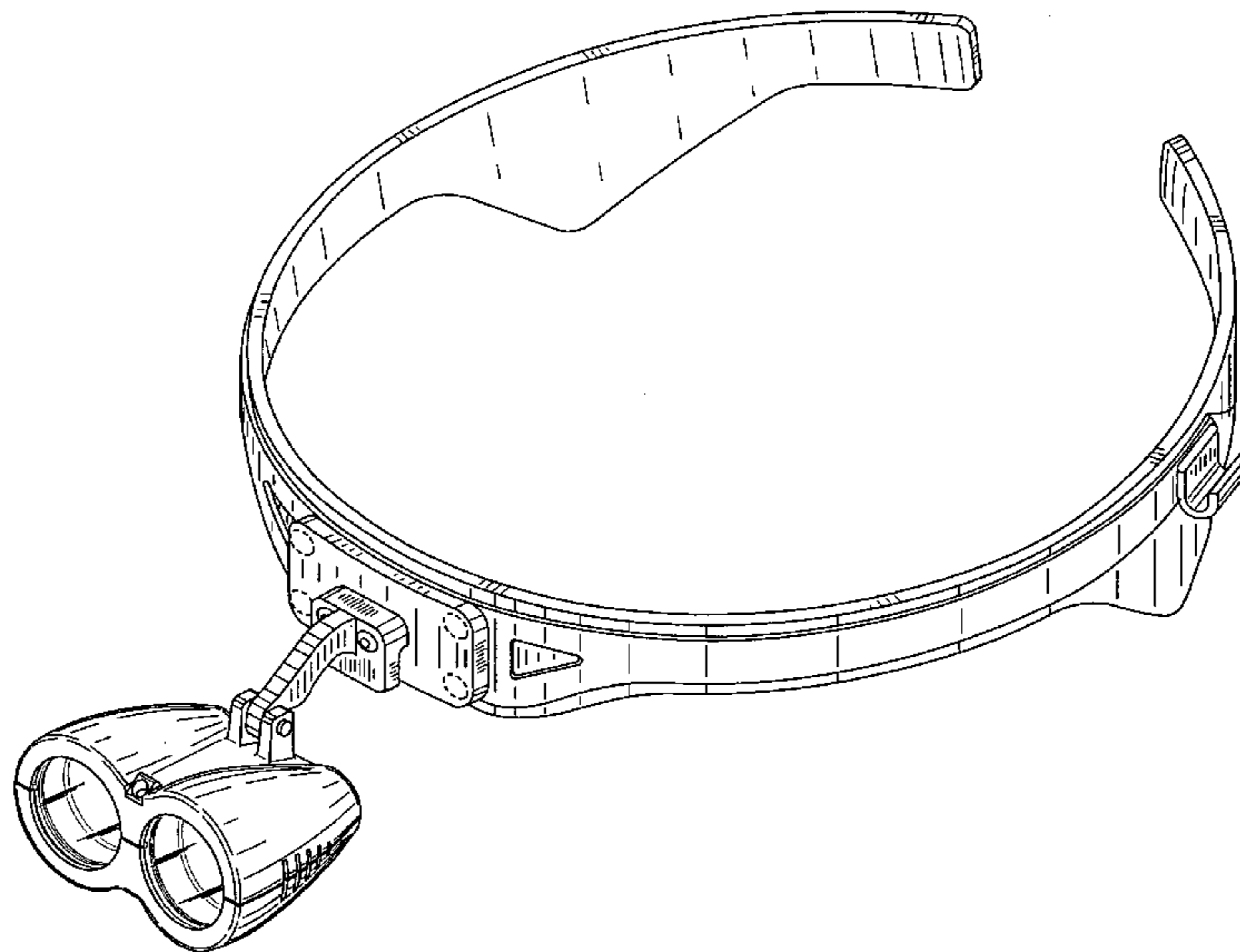

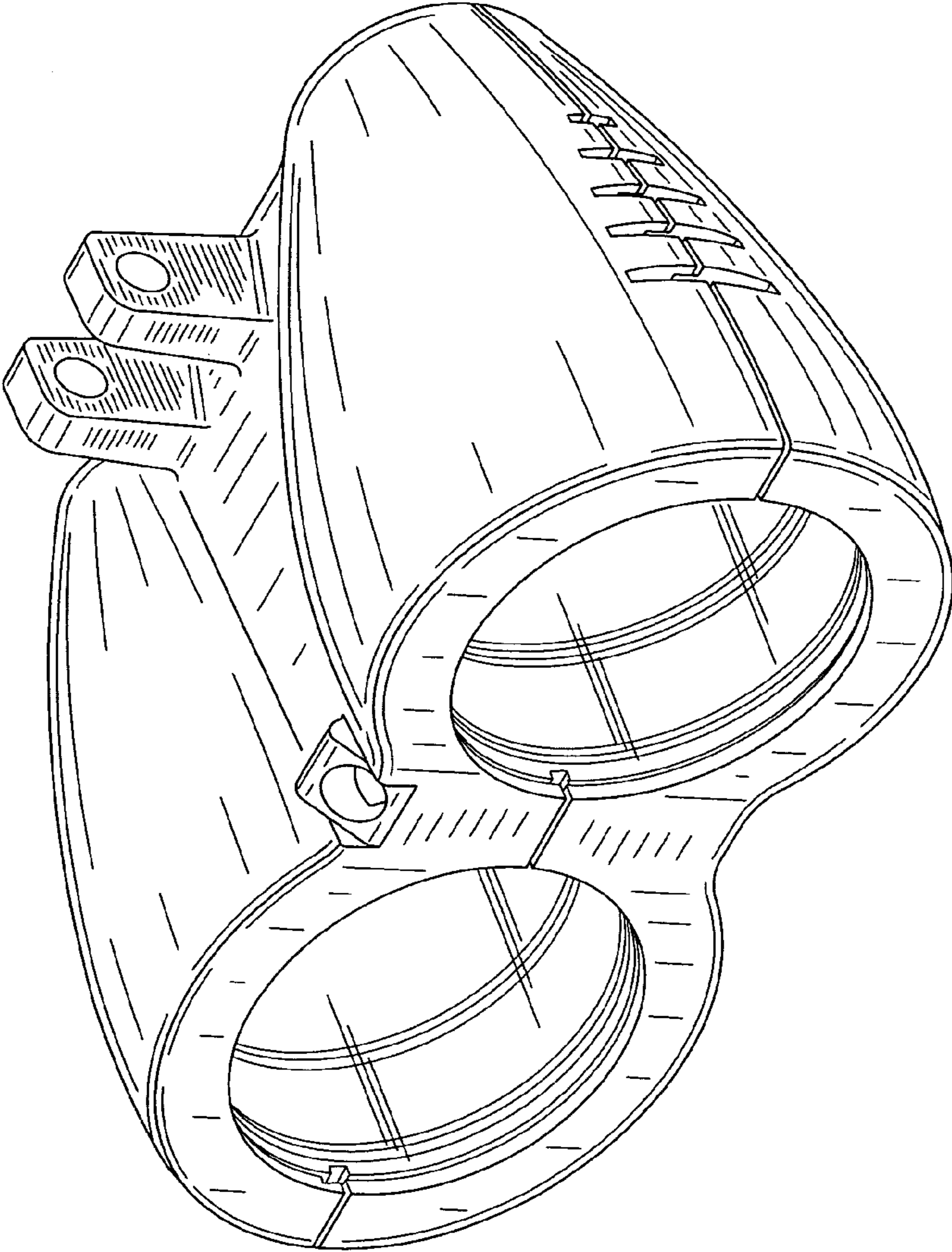

FIG. 1

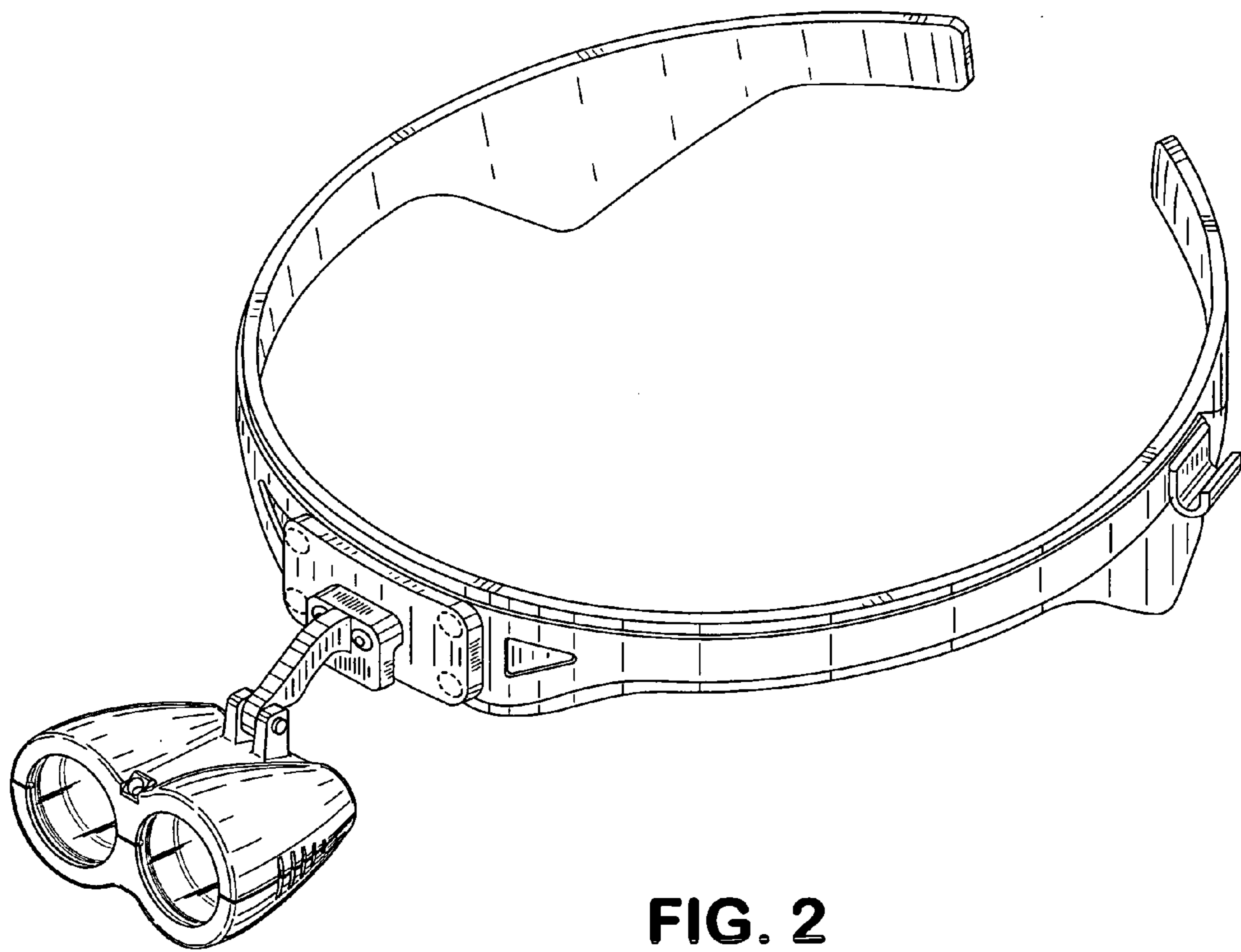
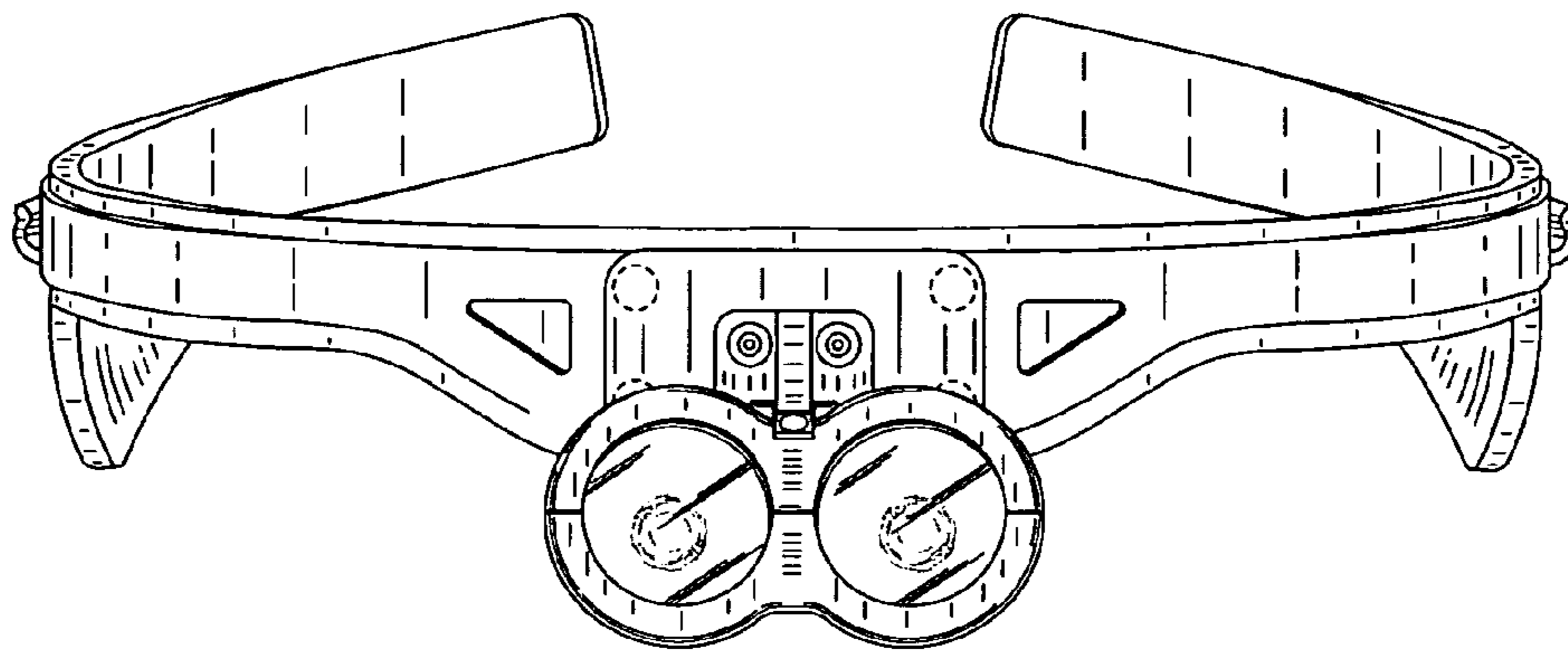
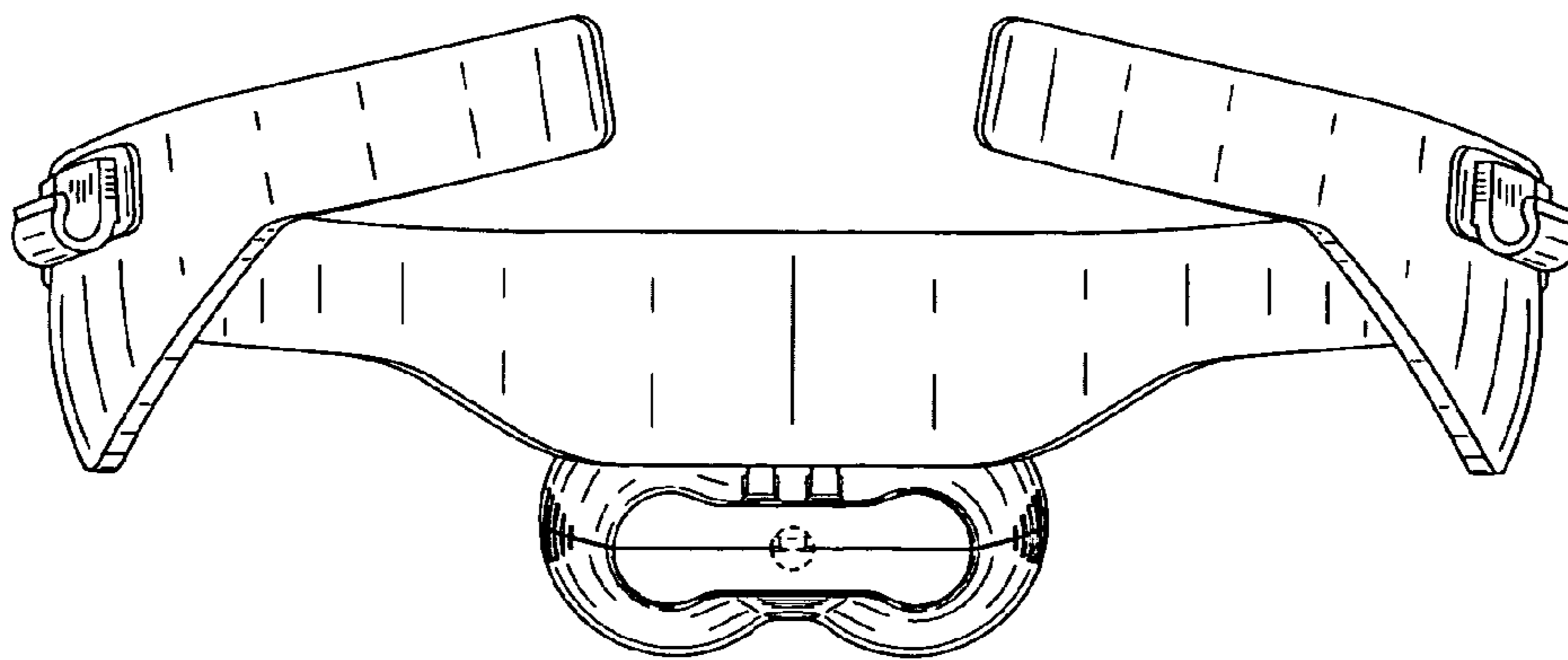

FIG. 2



**FIG. 3**



**FIG. 4**

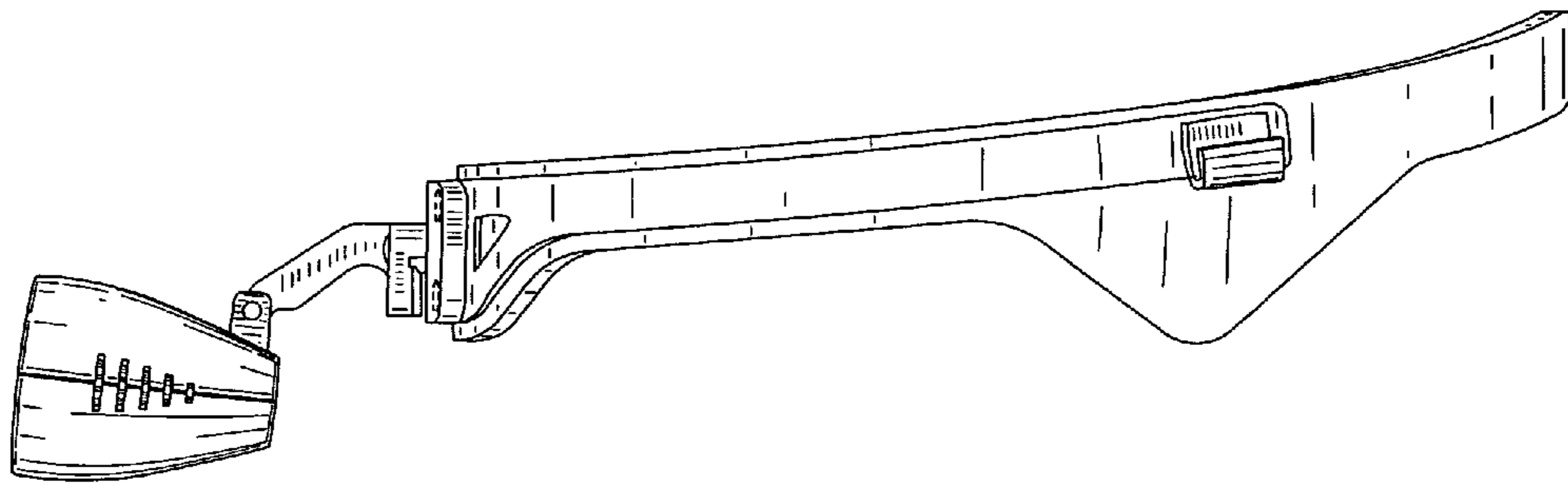

FIG. 5

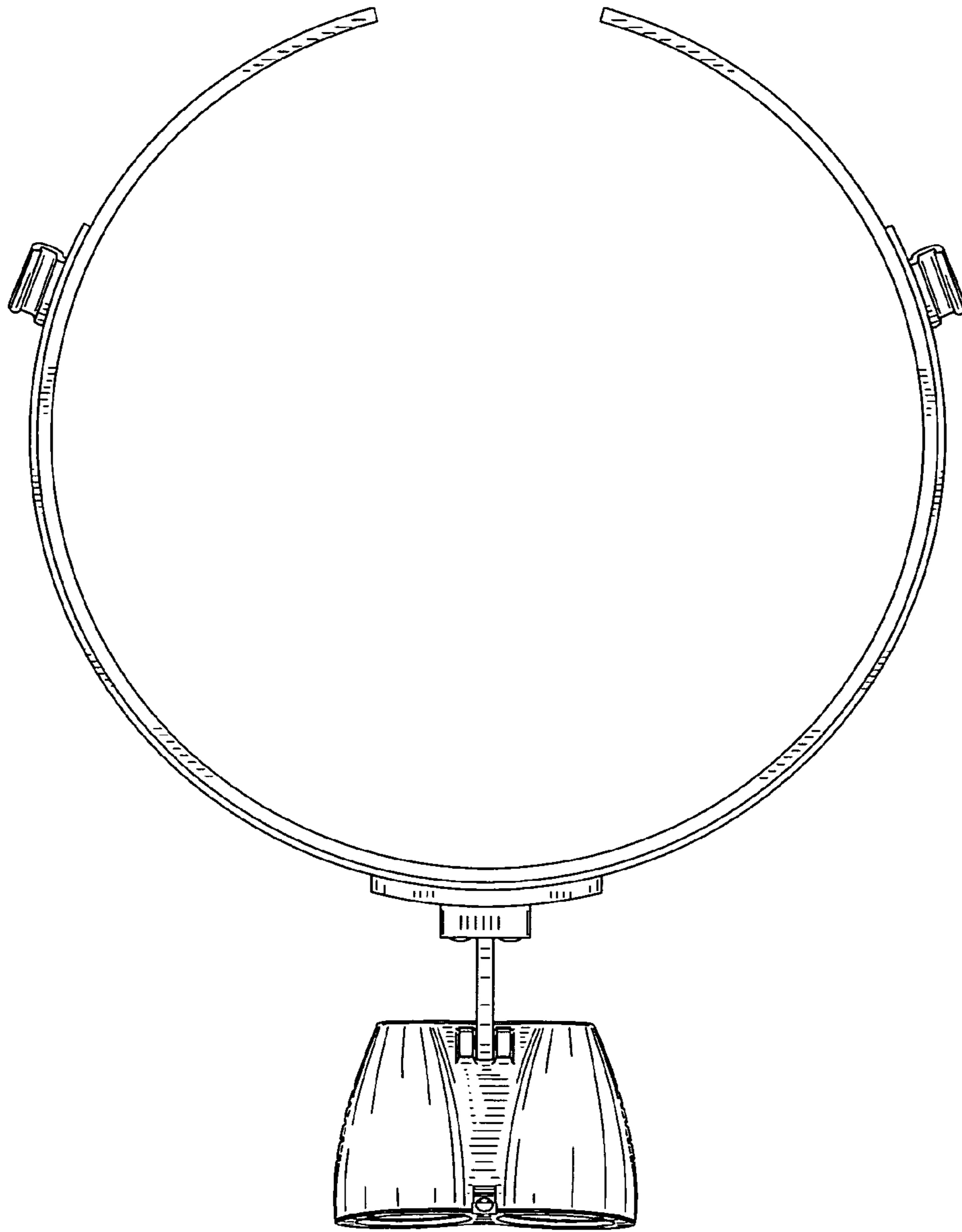
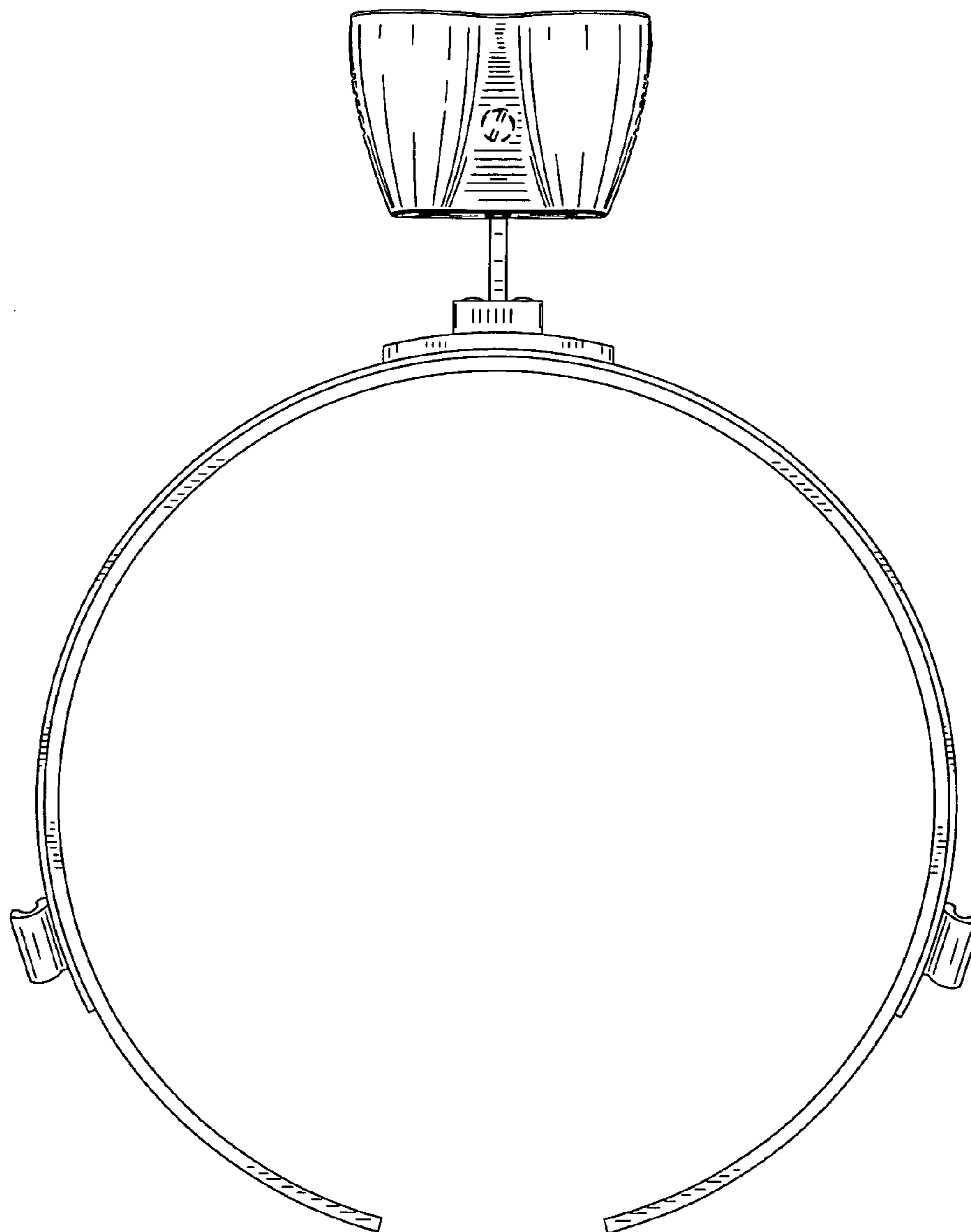

FIG. 6



**FIG. 7**

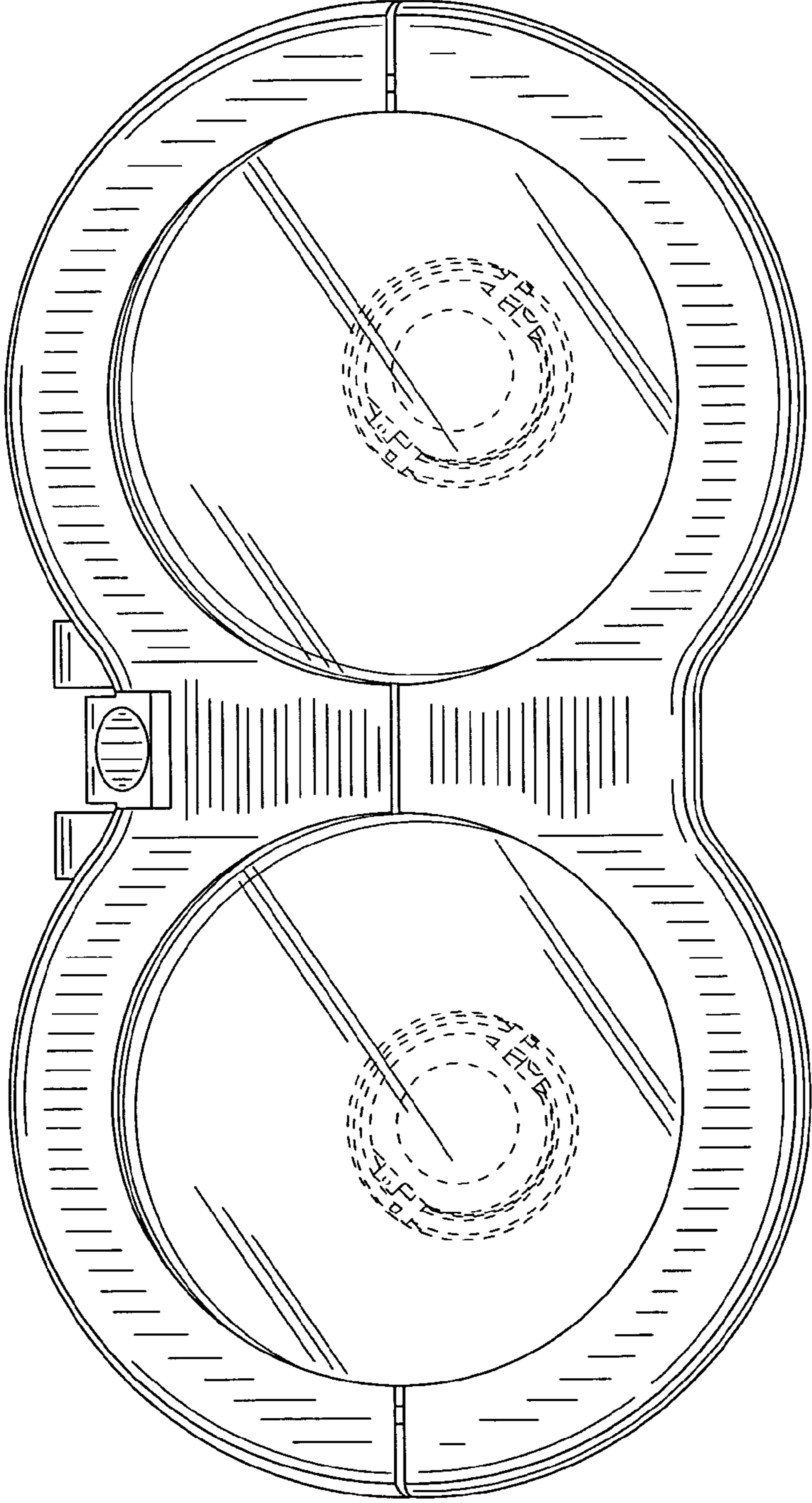

FIG. 8



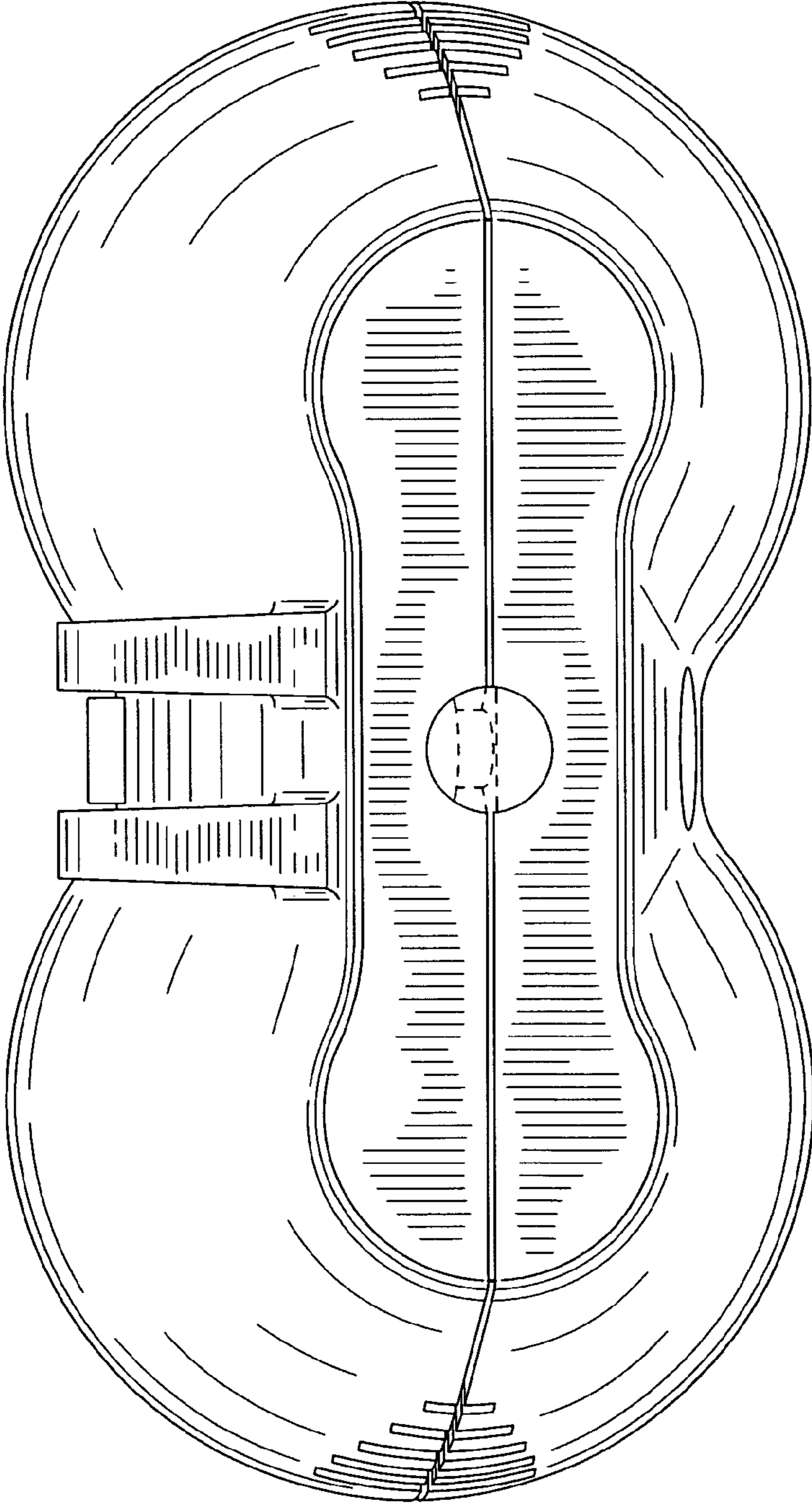

FIG. 9

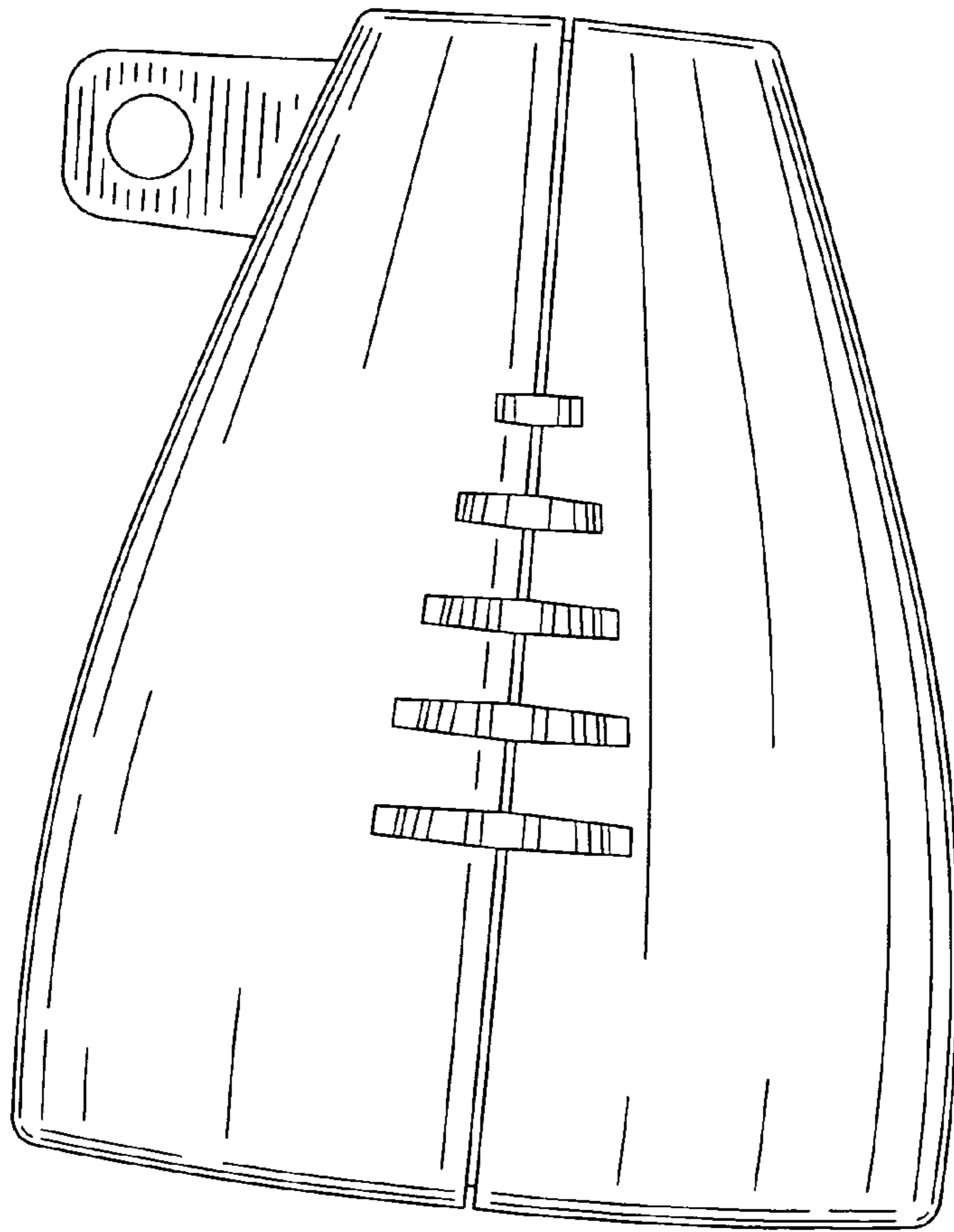

FIG. 10

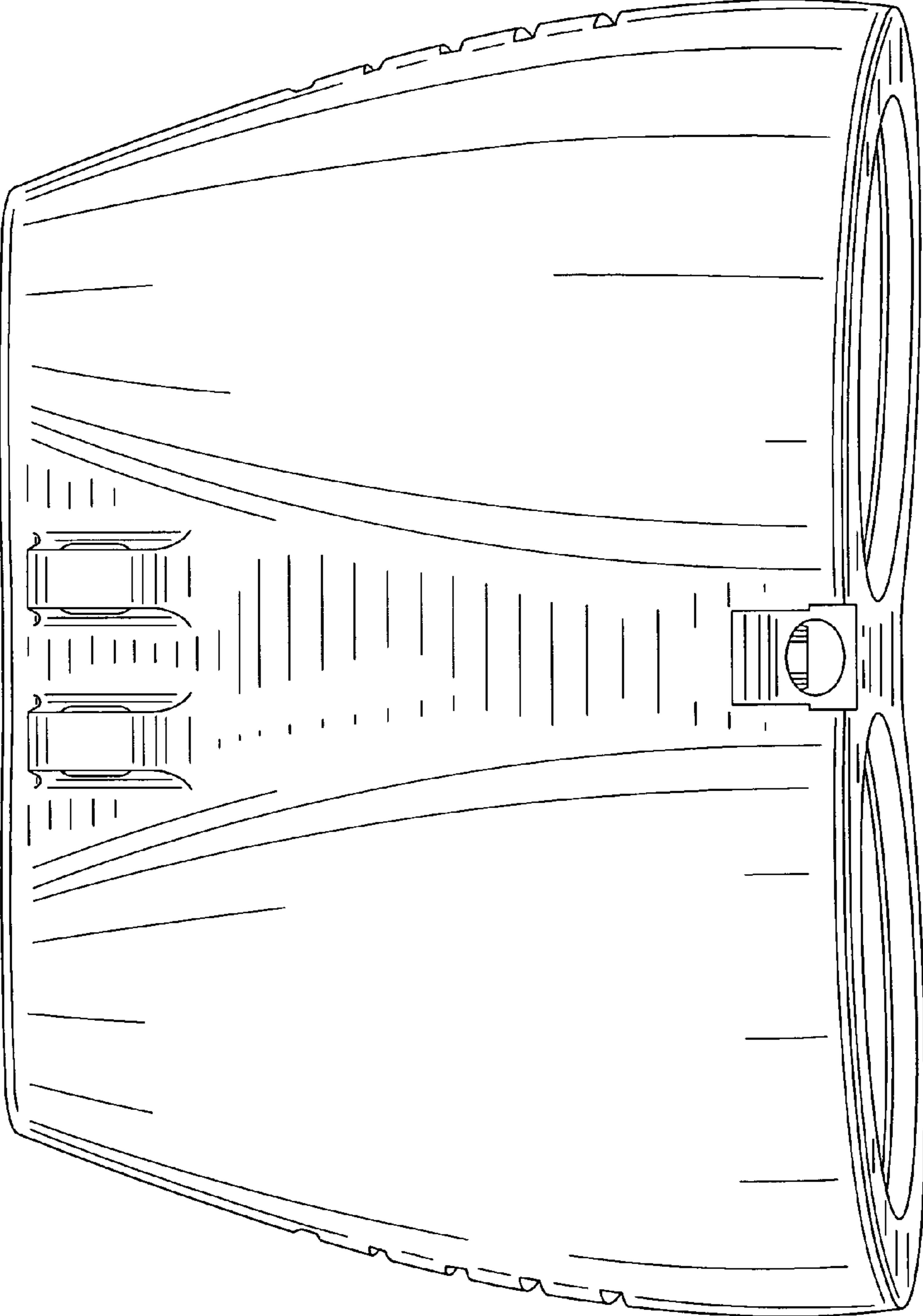

FIG. 11

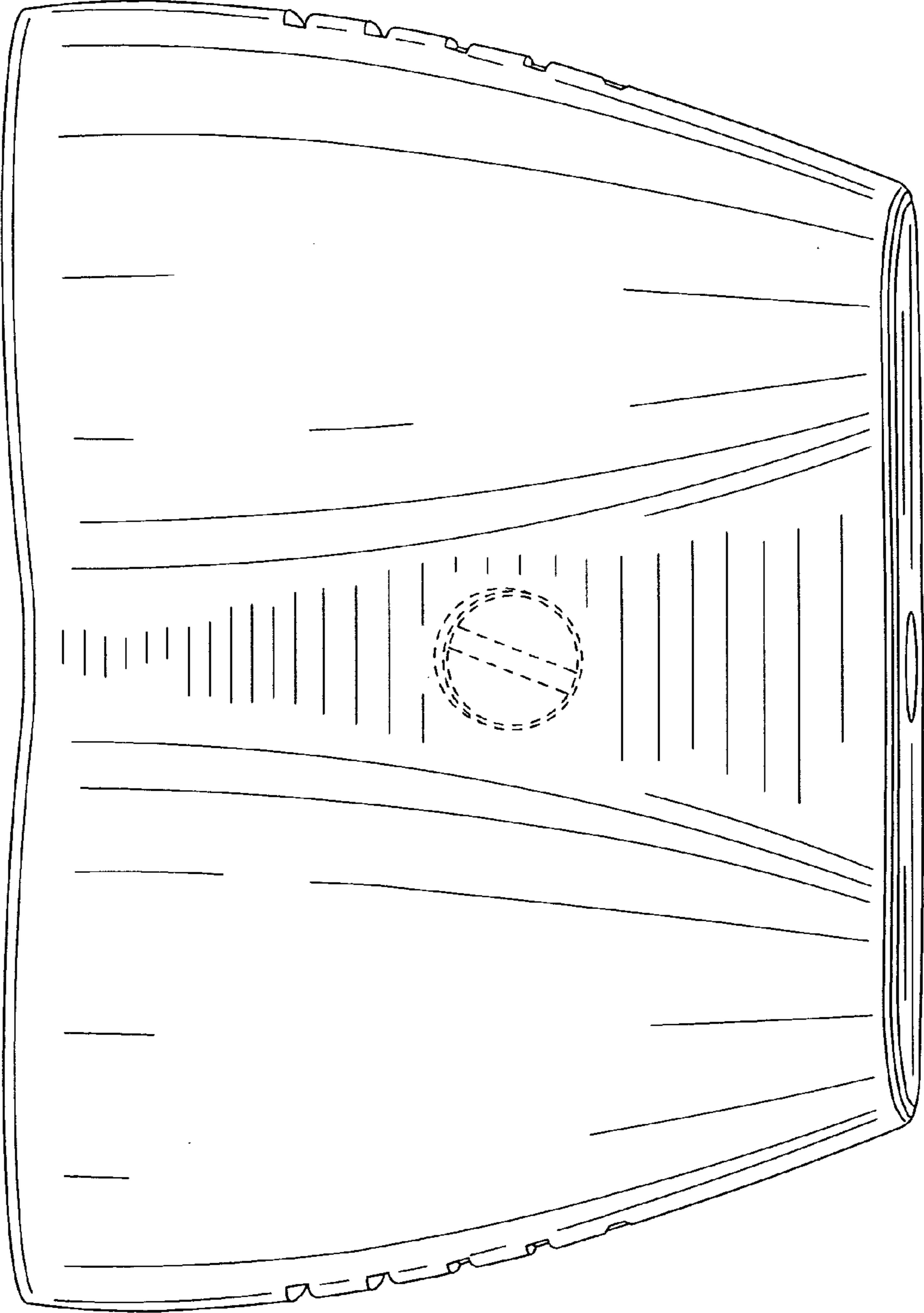

FIG. 12