



US00D615475S

(12) **United States Design Patent**
Corn

(10) **Patent No.:** **US D615,475 S**

(45) **Date of Patent:** **** May 11, 2010**

(54) **BOATING ACCESSORY**

(75) Inventor: **James F. Corn**, Kearney, MO (US)

(73) Assignee: **Sport Marine Technologies, Inc.**, Pilot Point, TX (US)

(**) Term: **14 Years**

(21) Appl. No.: **29/314,740**

(22) Filed: **Apr. 23, 2009**

Related U.S. Application Data

(62) Division of application No. 29/307,608, filed on Apr. 29, 2008, now Pat. No. Des. 591,664.

(51) **LOC (9) Cl.** **12-06**

(52) **U.S. Cl.** **D12/317**

(58) **Field of Classification Search** D12/300,
D12/308, 309, 316, 317; 114/125, 126, 300,
114/312, 315, 322, 330-333, 337, 274-280,
114/281, 285-287; 440/6, 33, 42, 51, 65,
440/66, 71, 76, 80

See application file for complete search history.

(56) **References Cited**

U.S. PATENT DOCUMENTS

2,319,640 A	5/1943	Sink	
2,963,000 A	12/1960	Fester	
2,998,795 A	9/1961	Downie et al	
3,099,240 A	7/1963	Montague Jr.	
3,114,343 A	12/1963	Headrick et al	
3,139,853 A	7/1964	McCarthy et al	
3,211,119 A	10/1965	Kiekhaefer	
3,343,512 A	9/1967	Rasmussen	
3,433,195 A	3/1969	Poole	
3,765,356 A	10/1973	Cook	
3,964,417 A	6/1976	Williams et al.	
4,040,373 A	8/1977	Jones, Jr.	
4,100,876 A	7/1978	Feleus	
4,205,618 A	6/1980	Olsson	
4,304,557 A *	12/1981	Henrich	440/66
4,323,355 A	4/1982	Kondo	
4,487,152 A	12/1984	Larson	

4,597,742 A	7/1986	Finkl	
4,708,672 A	11/1987	Bentz et al.	
4,738,644 A	4/1988	Happel	
4,744,779 A	5/1988	Koehler	
4,756,265 A	7/1988	Lane	
D308,851 S	6/1990	Templeman	
D311,513 S	10/1990	Templeman	
5,048,449 A	9/1991	Templeman	
5,107,786 A	4/1992	Templeman	
D328,732 S	8/1992	Whitley, II	
5,138,966 A	8/1992	Whitley et al.	
D331,738 S	12/1992	Simpson	
5,178,089 A	1/1993	Hodel	
5,203,275 A	4/1993	Brauner et al.	
5,231,950 A	8/1993	Poulos	
D351,129 S	10/1994	Templeman	
D352,023 S	11/1994	Corn	
5,425,663 A	6/1995	Meisenburg et al.	
D363,914 S	11/1995	Corn	
5,493,990 A *	2/1996	Dyer	114/282
5,638,765 A	6/1997	Poulos	
5,848,922 A	12/1998	Itima et al.	
6,503,110 B2	1/2003	Lampli	
6,948,441 B2	9/2005	Levine	
7,011,559 B1	3/2006	Moldenhauer	
D533,497 S	12/2006	Templeman	
7,232,355 B2	6/2007	Woolley	
7,270,584 B1	9/2007	Mitchell	
D589,866 S *	4/2009	Templeman et al.	D12/317
D590,760 S *	4/2009	Templeman et al.	D12/317
7,520,238 B2 *	4/2009	Patterson	114/274

FOREIGN PATENT DOCUMENTS

GB	716879	10/1954
SE	266596	5/1969

OTHER PUBLICATIONS

Portion of front of package insert, XRIII hydrofoil, dated 2007 from Marine Dynamics, Inc.
 Portion of back of package insert, XRIII hydrofoil, dated 2007 from Marine Dynamics, Inc.
 Internet catalog of Marine Dynamics, Inc. downloaded 2008.
 Ad from Marine Dynamics, Inc. date unknown.
 Advertisement, Sting Ray Hydrofoil Stabilizer, IMTEC 1994.
 Article, Build Your Own Ski Boat, Waterski, Nov./Dec. 1994, Author Pierce Hoover.
 Advertisement, Doel-fin Boat Stabilizer, Doelcher Products, Inc., 1979.

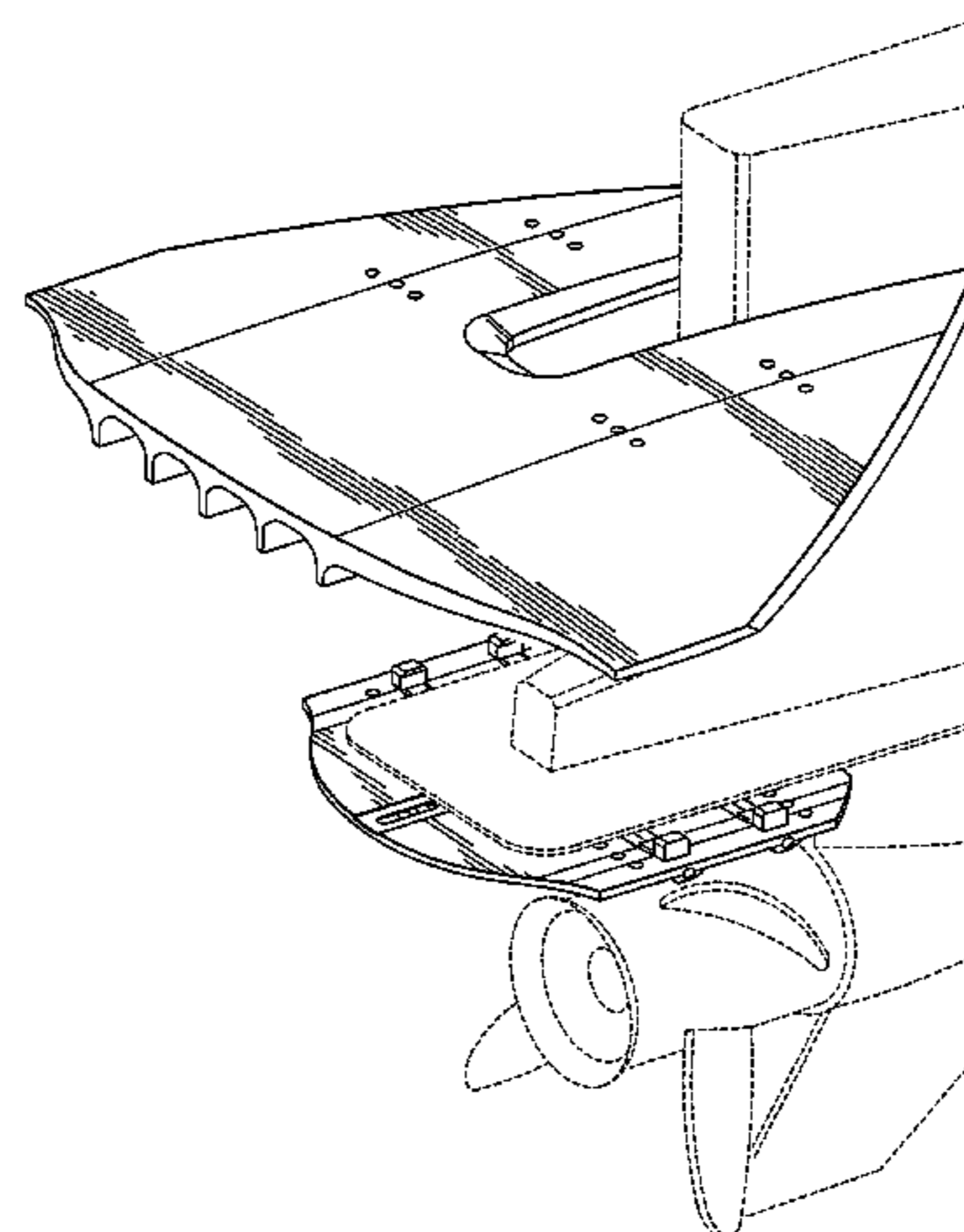
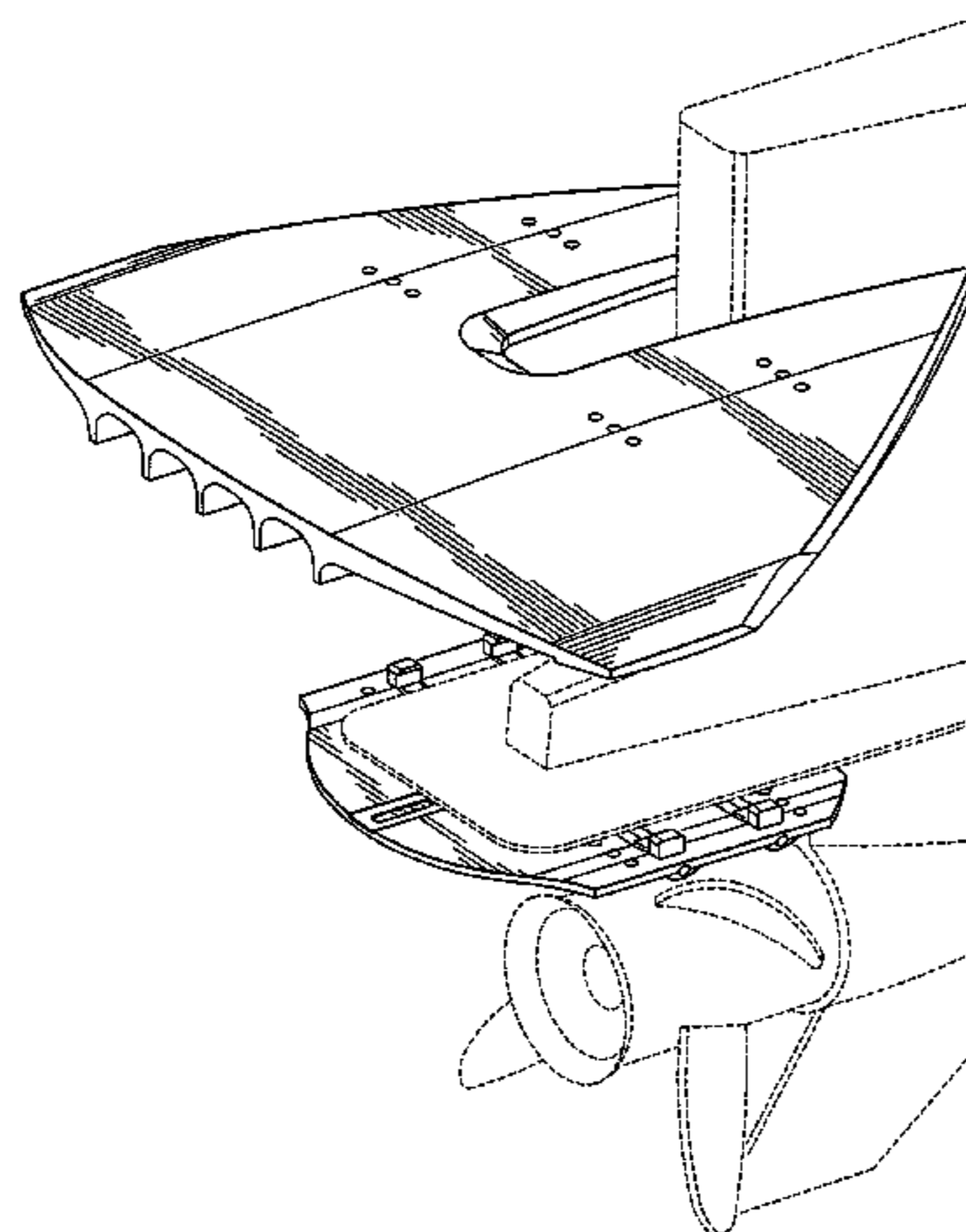

Article, Doel-fin - Not Just Another Gadget, Jul. 1979.
Advertisement, Break-Through of Doel-fin Stabilizer, 1979.
Article, Hydrofoils: How Good Are They?, Trailer Boats, 4/94; pages cover, 64-69.
Article, Hydrofoils: How Good Are They? by Jim Barron, 1994.
Advertisement, Hydrofoil G.T., Hydrofoil International Corp., 1994.
Advertisement, Sting Ray Hydrofoil Stabilizer, 1988, Marine Dynamics, Inc.
Advertisement, Trailer Boats, p. 130 Sting Ray Hydrofoil Stabilizer, 1988.
Advertisement, Bass Pro, p. 100, 1988.
Advertisement, p. 36, 1991.

* cited by examiner

Primary Examiner—Philip S Hyder
Assistant Examiner—Cynthia M Chin
(74) *Attorney, Agent, or Firm*—Gustavson, PC

(57) **CLAIM**

The ornamental design for a boating accessory, as shown and described.

DESCRIPTION

FIG. 1 is a top perspective view of the 1st embodiment of a boat accessory embodying my design being mounted on an anti-ventilation plate and outboard motor shown in dotted line to show the environment of its use and forming no part of the present invention;

FIG. 2 is a perspective top view of the lower element shown separately;

FIG. 3 is a perspective bottom view of FIG. 2;

FIG. 4 is a front view of FIG. 2;

FIG. 5 is a right side view of FIG. 2, the left side view being a mirror image thereof;

FIG. 6 is a back view of FIG. 2;

FIG. 7 is a top view of FIG. 2;

FIG. 8 is a bottom view of FIG. 2;

FIG. 9 is a perspective top view of the upper element of FIG. 1 shown separately;

FIG. 10 is a perspective bottom view of FIG. 9;

FIG. 11 is a back view of FIG. 9;

FIG. 12 is a right side view of FIG. 9, the left side view being a mirror image thereof;

FIG. 13 is a front view of FIG. 9;

FIG. 14 is a top view of FIG. 9;

FIG. 15 is a bottom view of FIG. 9;

FIG. 16 is a top perspective view of the 2nd embodiment of a boat accessory embodying my design, the lower element being the same as the one shown in FIGS. 2–8, being mounted on an anti-ventilation plate and outboard motor shown in dotted line to show the environment of its use and forming no part of the present invention;

FIG. 17 is a perspective top view of the upper element of FIG. 16 shown separately;

FIG. 18 is a perspective bottom view of FIG. 17;

FIG. 19 is a back view of FIG. 17;

FIG. 20 is a right side view of FIG. 17, the left side view being a mirror image thereof;

FIG. 21 is a front view of FIG. 17;

FIG. 22 is a top view of FIG. 17; and,

FIG. 23 is a bottom view of FIG. 17.

The broken lines in FIGS. 1 and 16 represent the environment in which the design resides. Broken lines shown in all other figures represent portions of the design that form no part of the claim. None of the broken lines form a part of the claimed design. Elements are shown separately in FIGS. 2–15 and 17–23 for the clarity of illustration.

1 Claim, 15 Drawing Sheets

FIG. 1

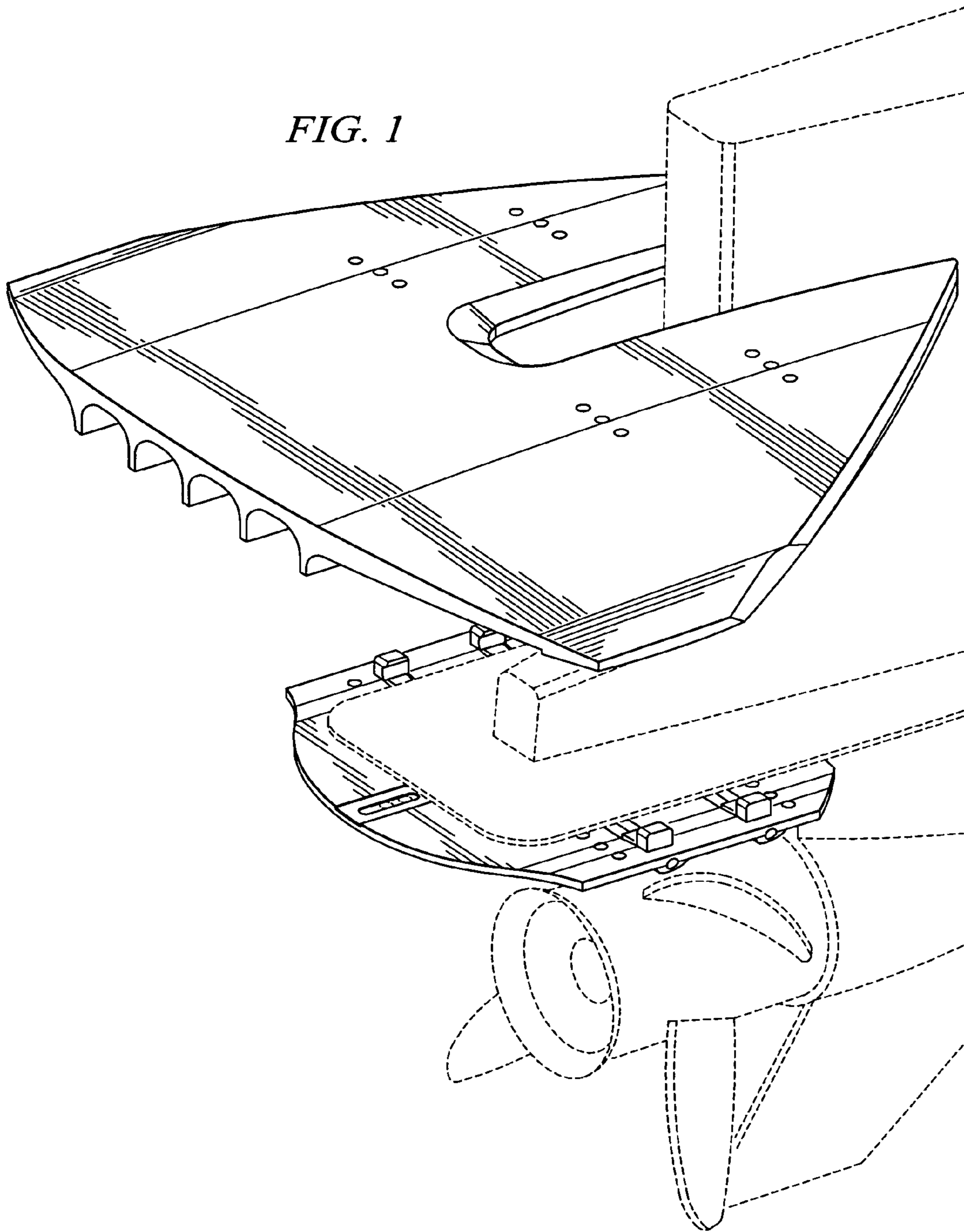

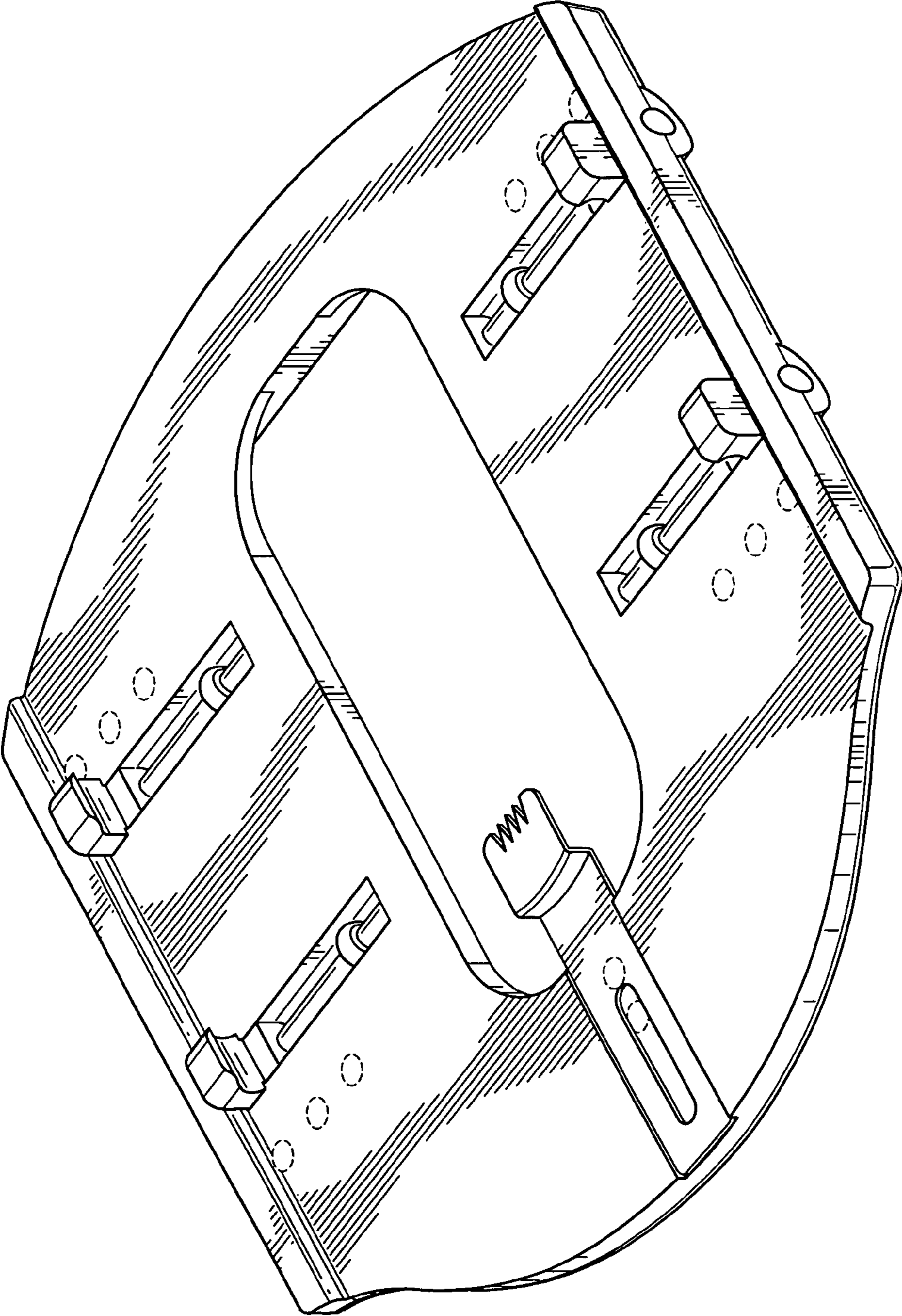

FIG. 2

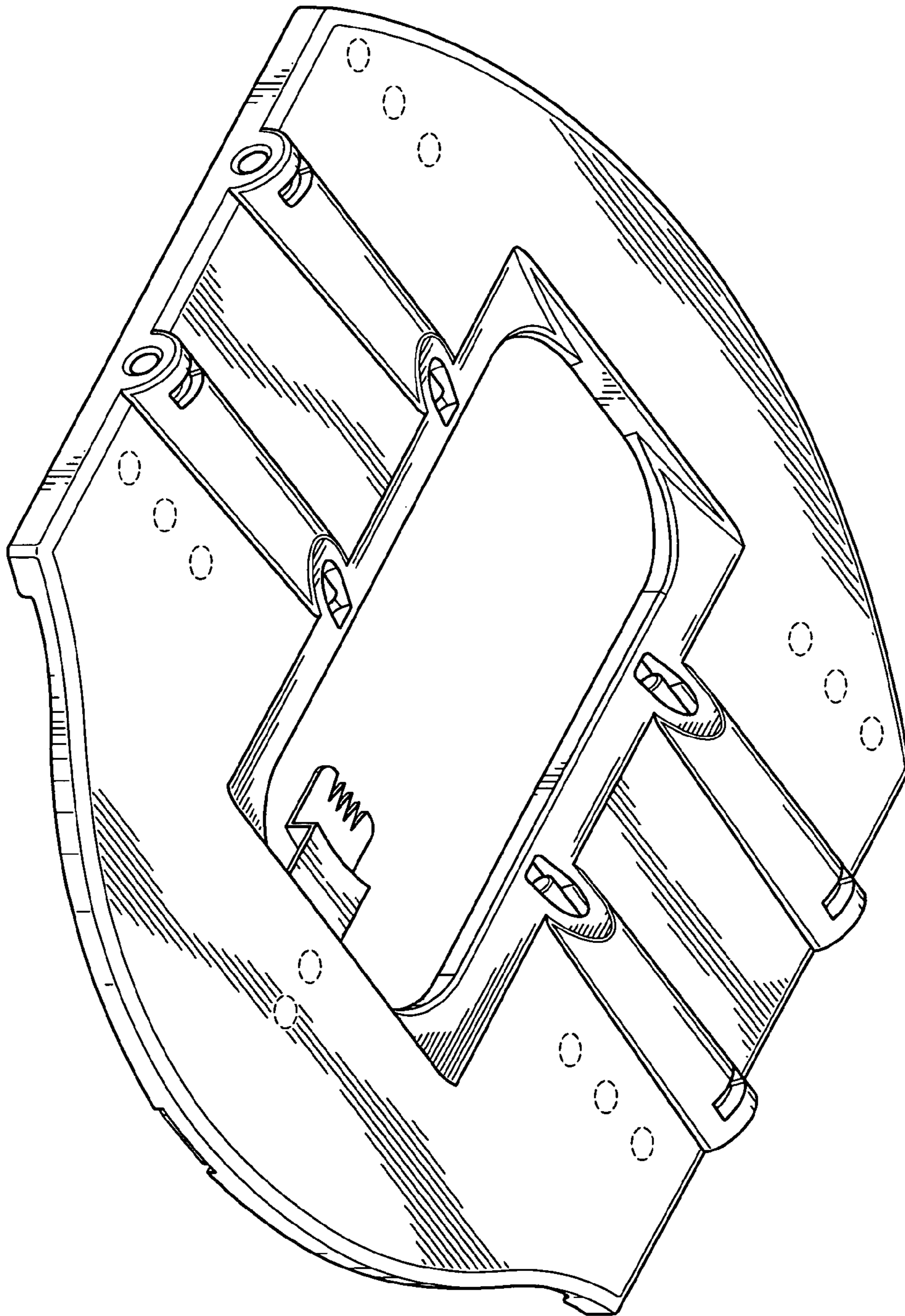

FIG. 3

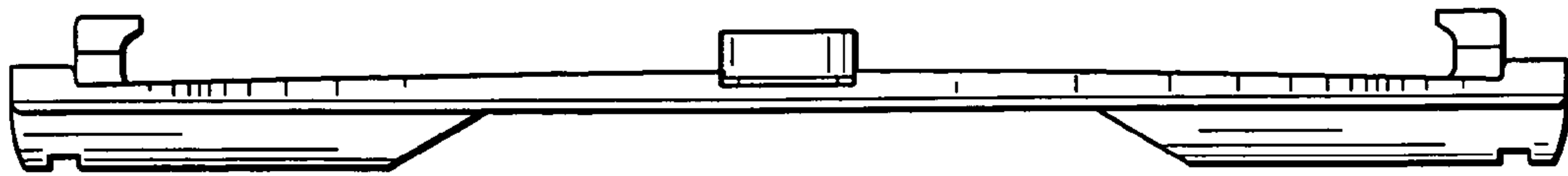

FIG. 4

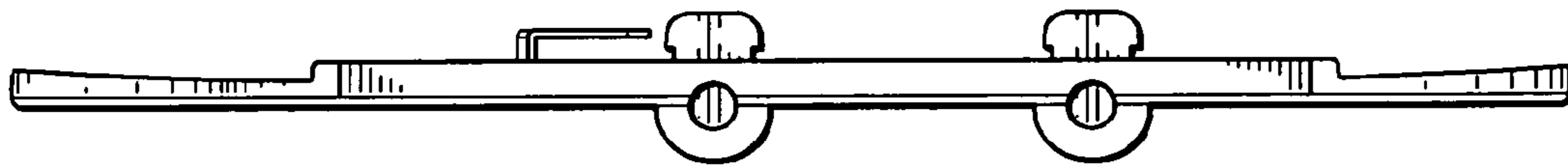

FIG. 5

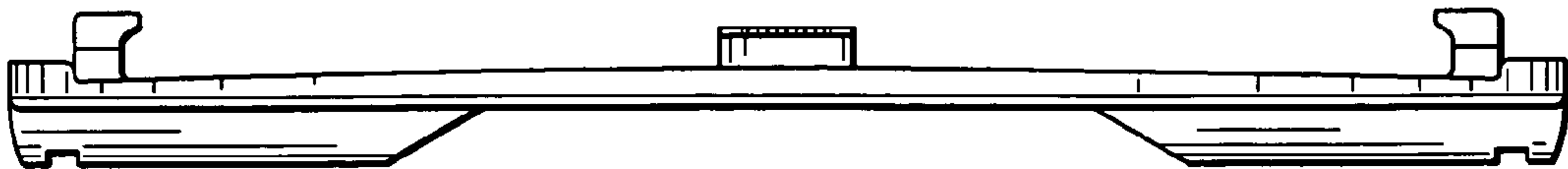

FIG. 6

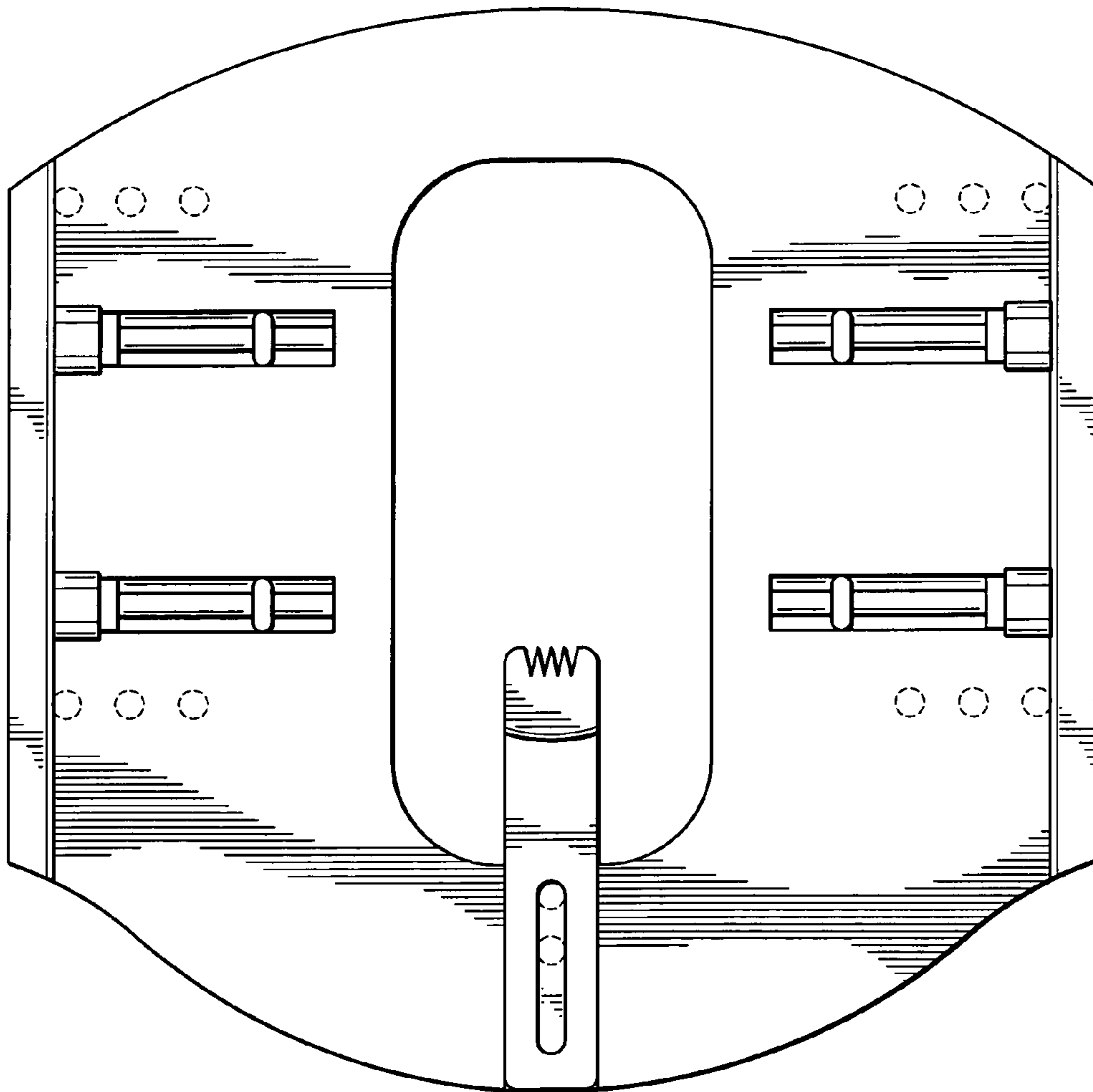

FIG. 7

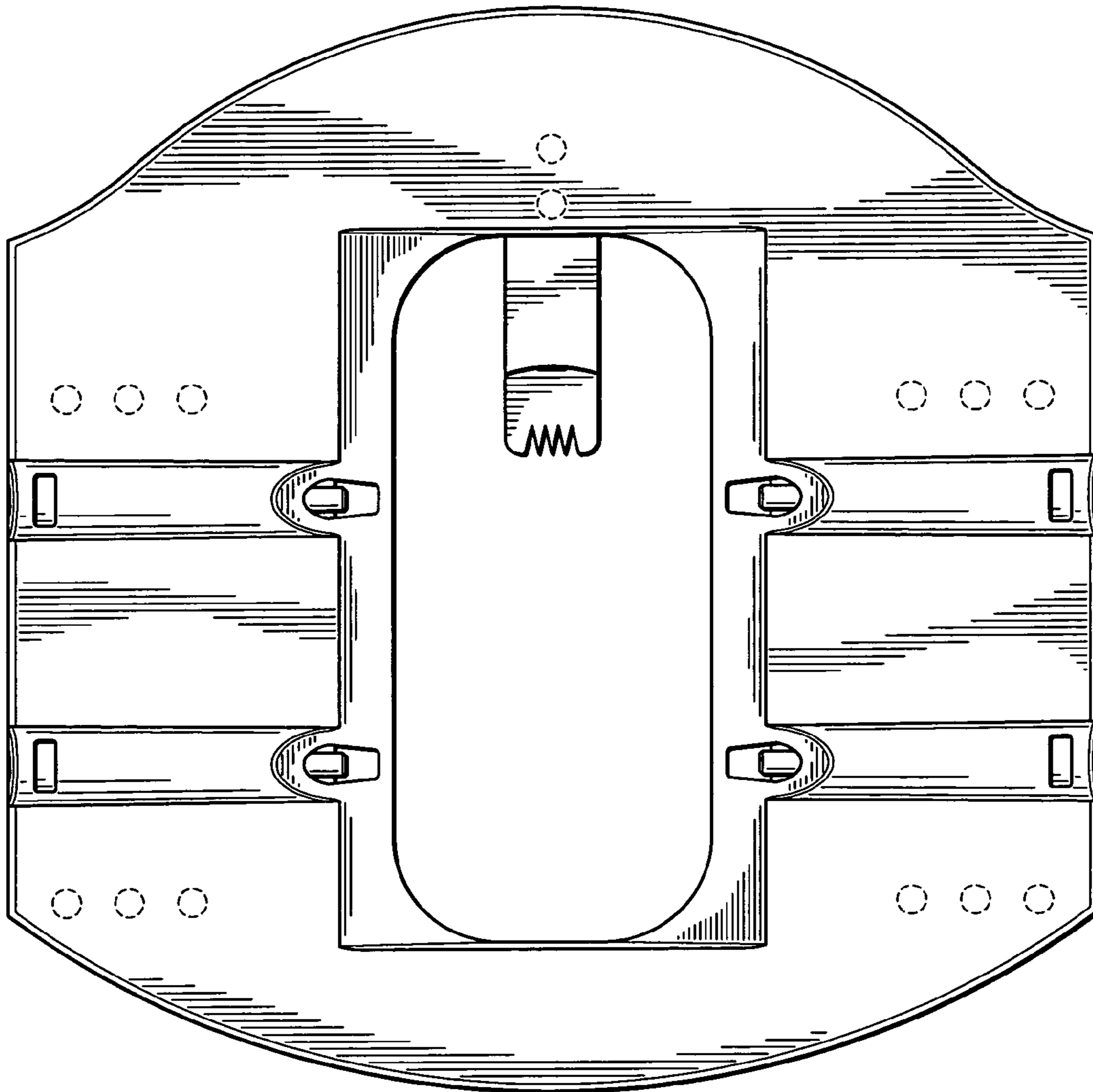

FIG. 8

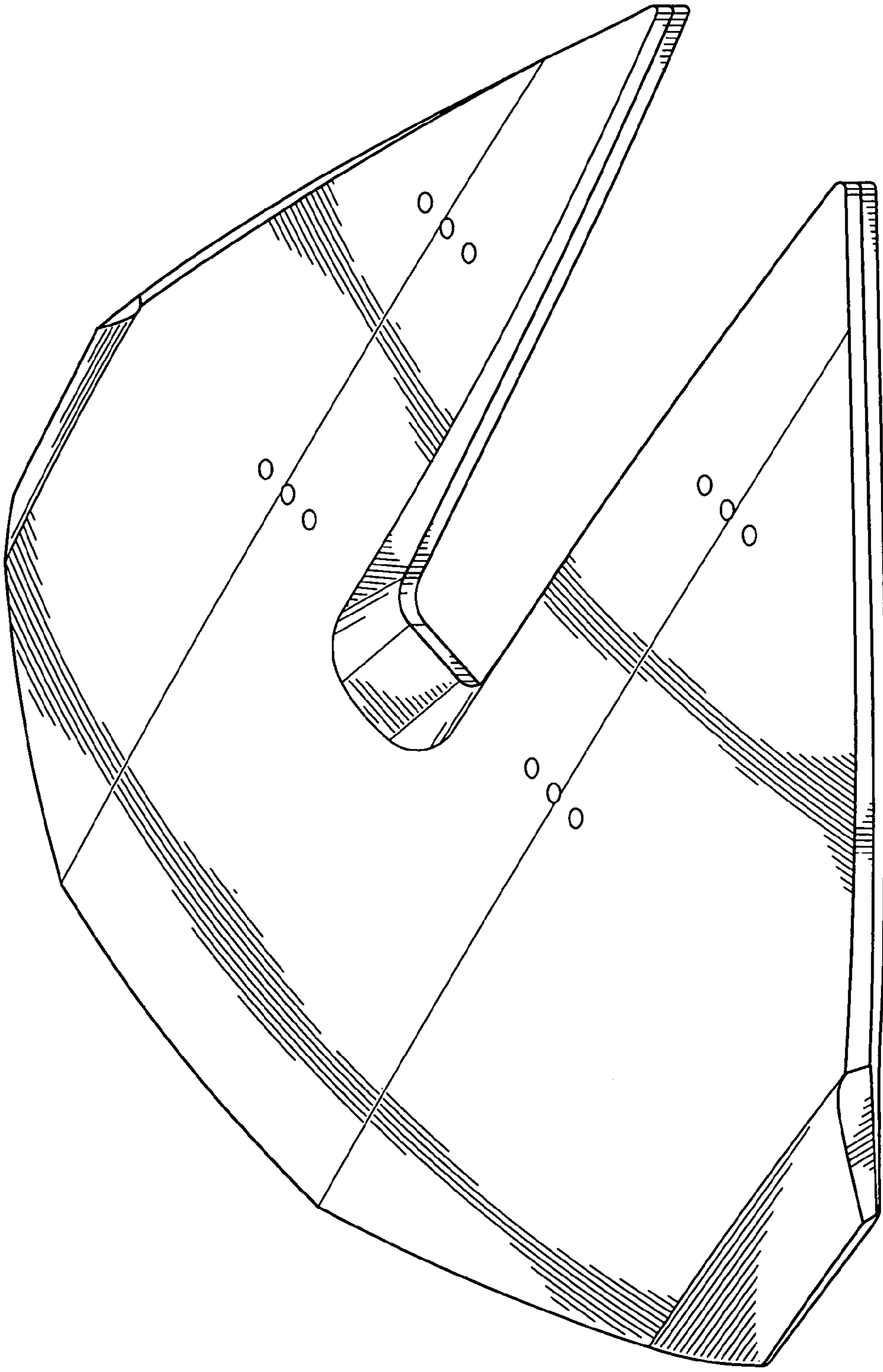

FIG. 9

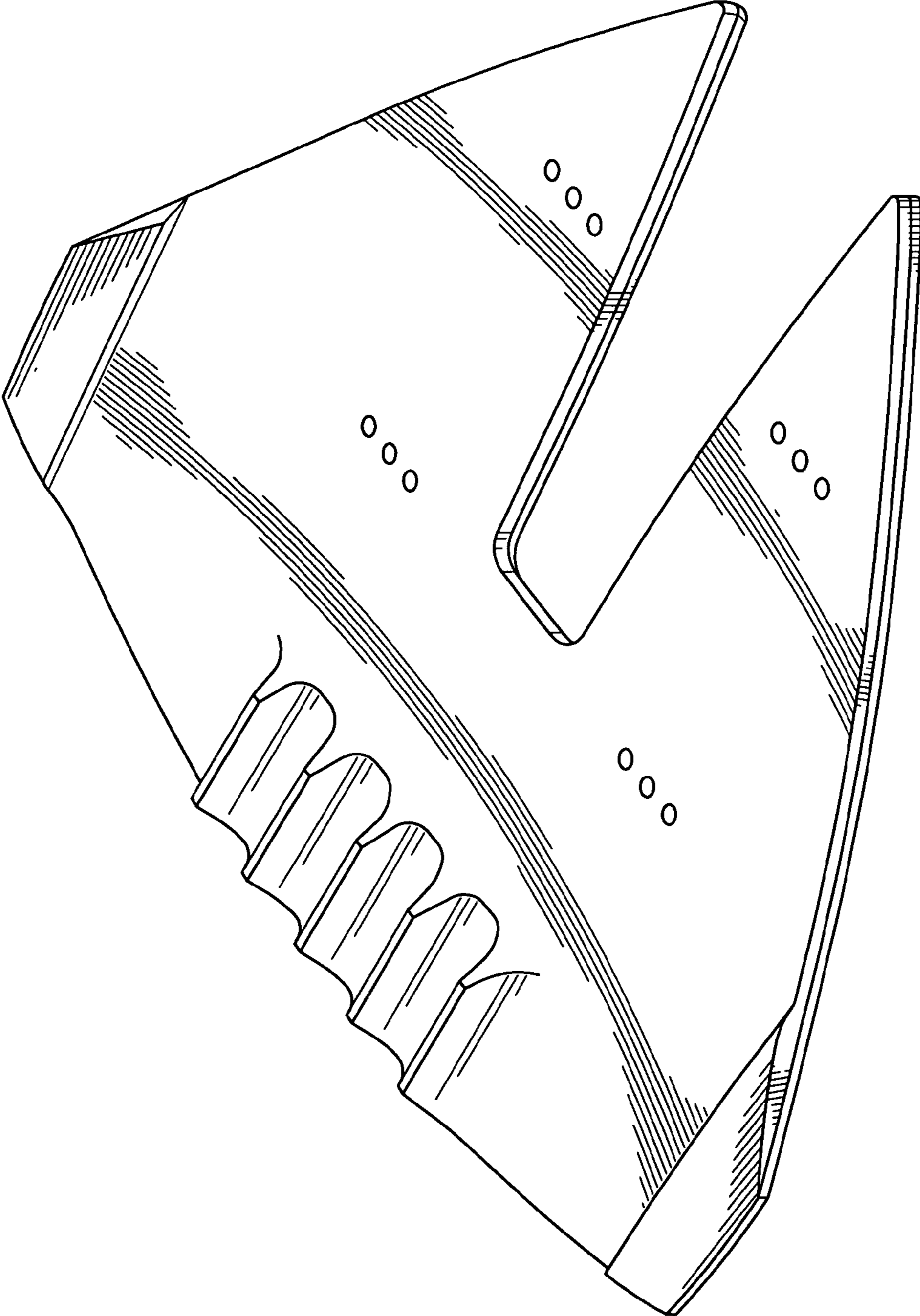
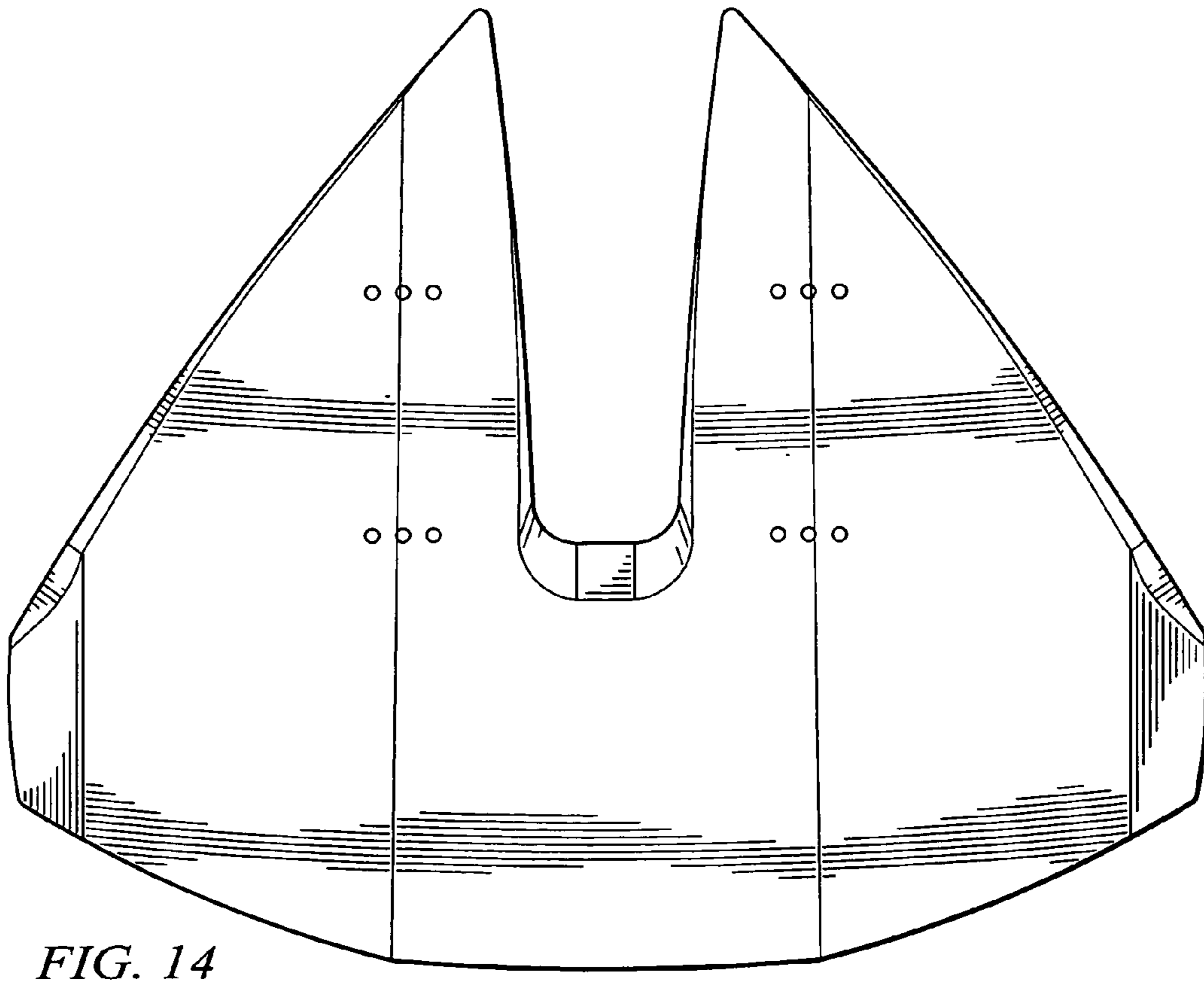
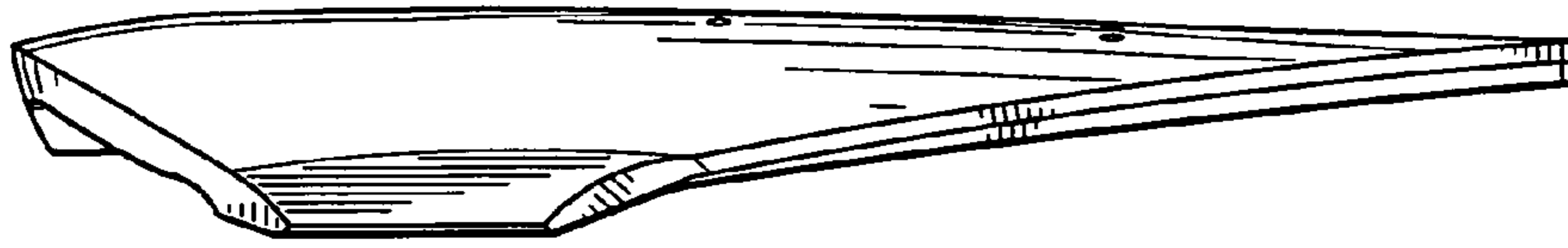
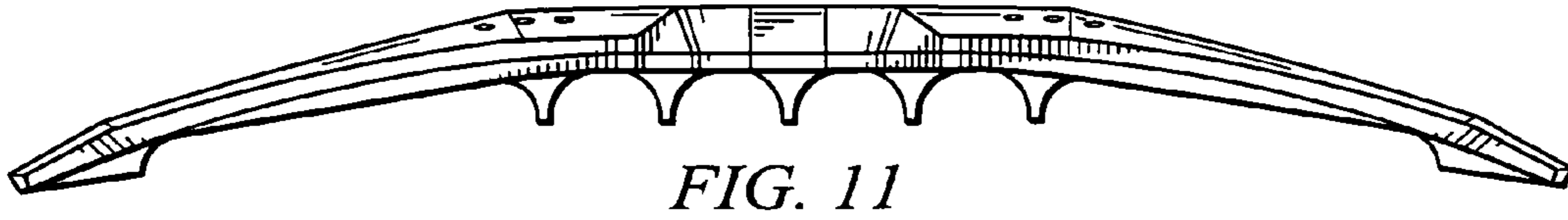

FIG. 10



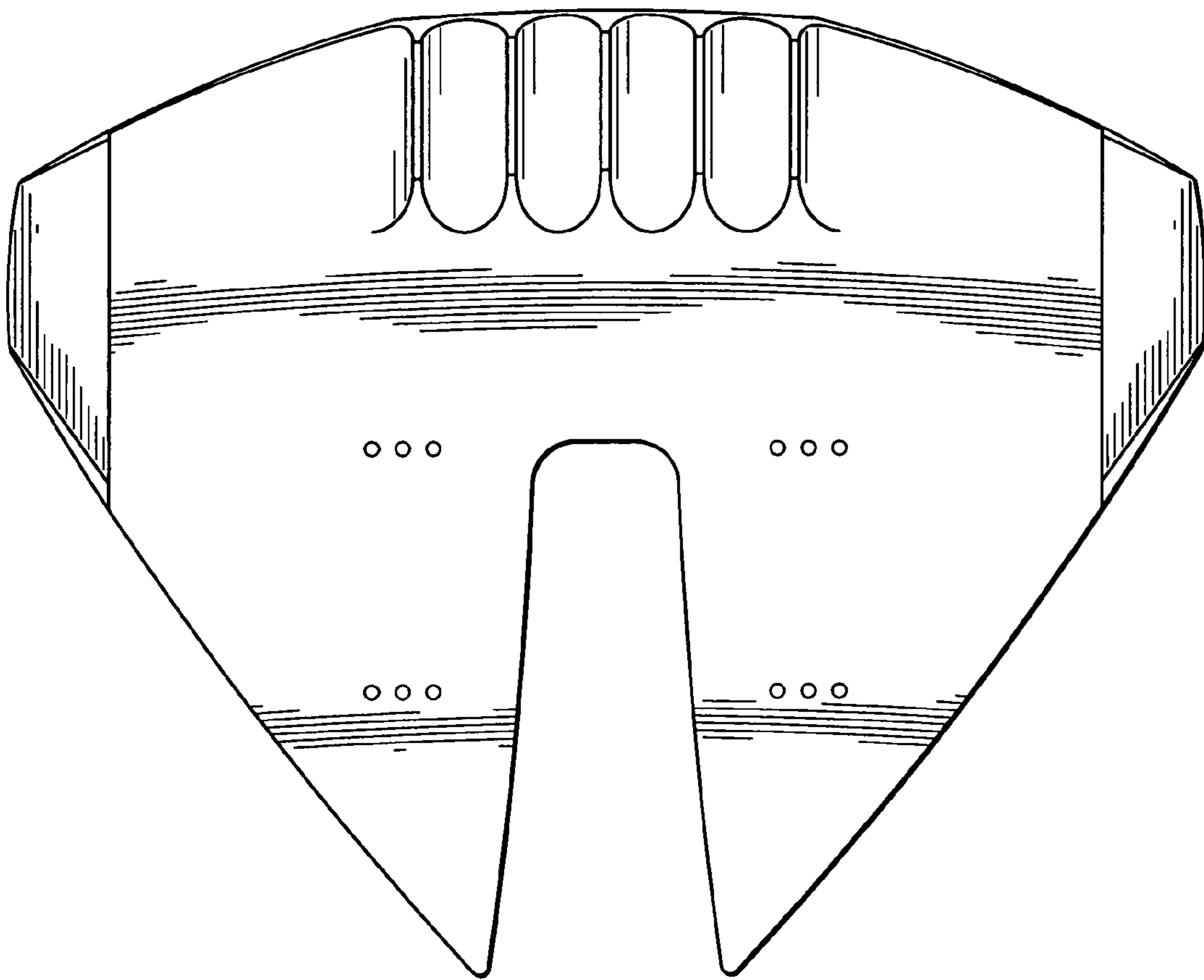
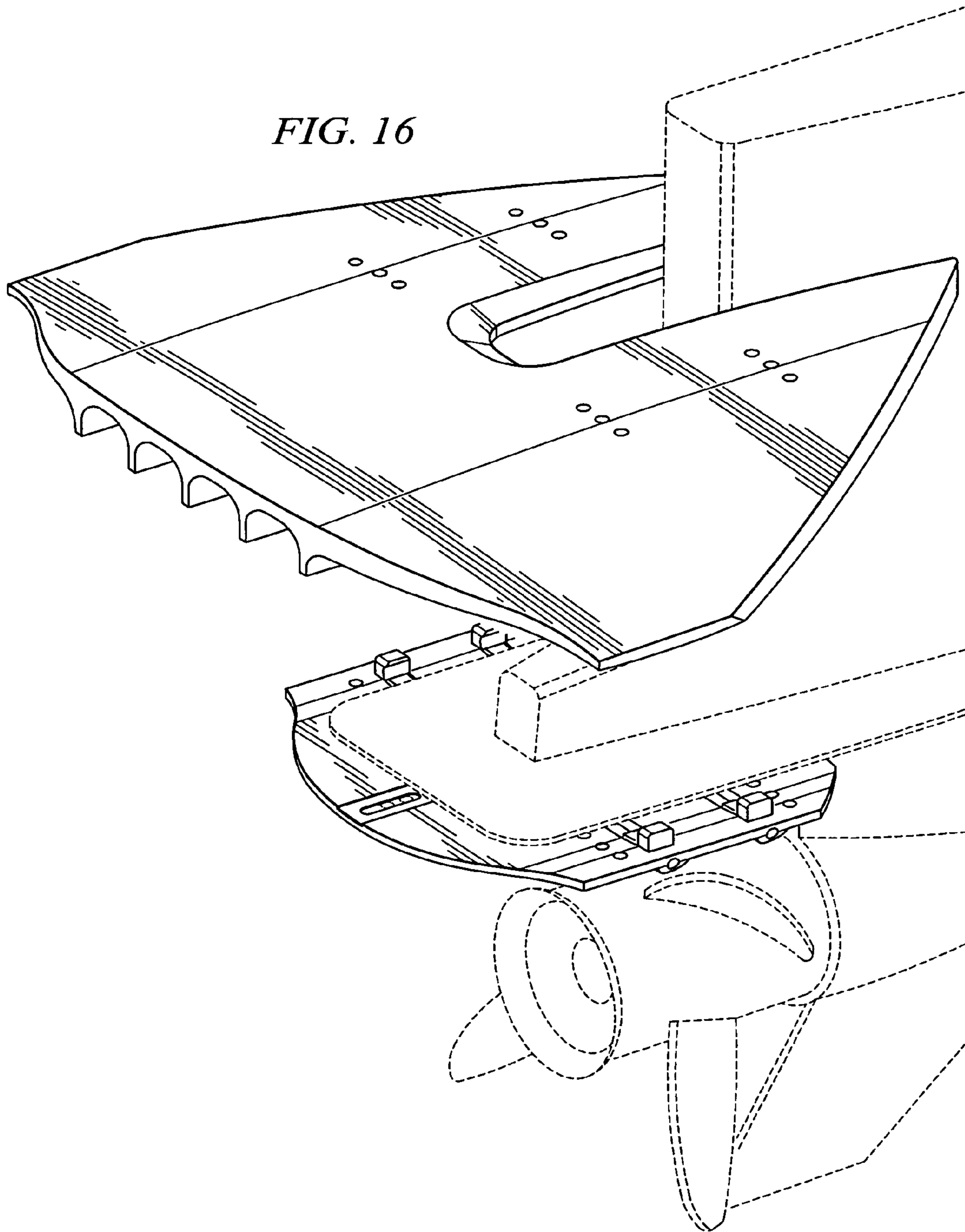

FIG. 15

FIG. 16



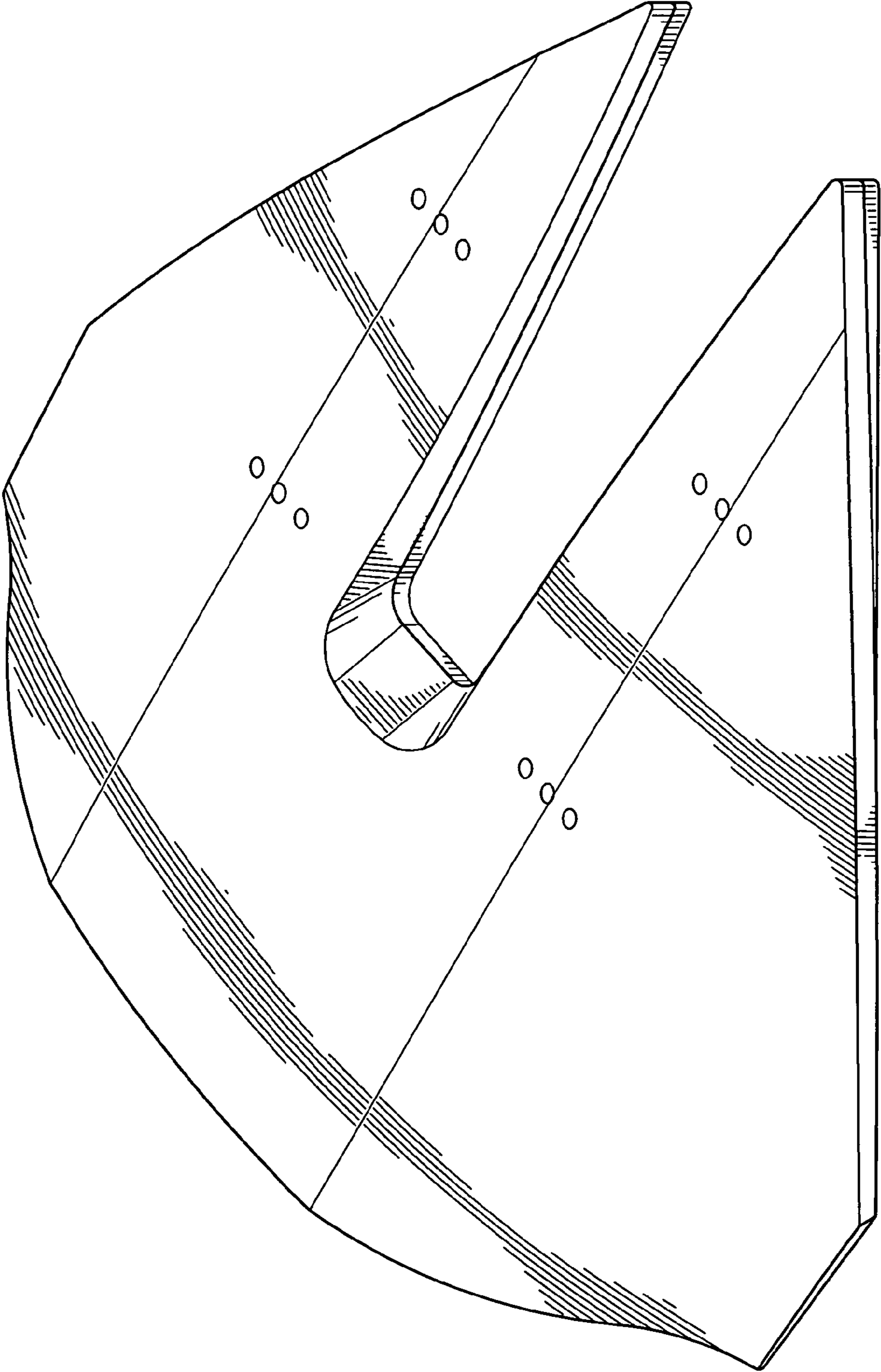

FIG. 17

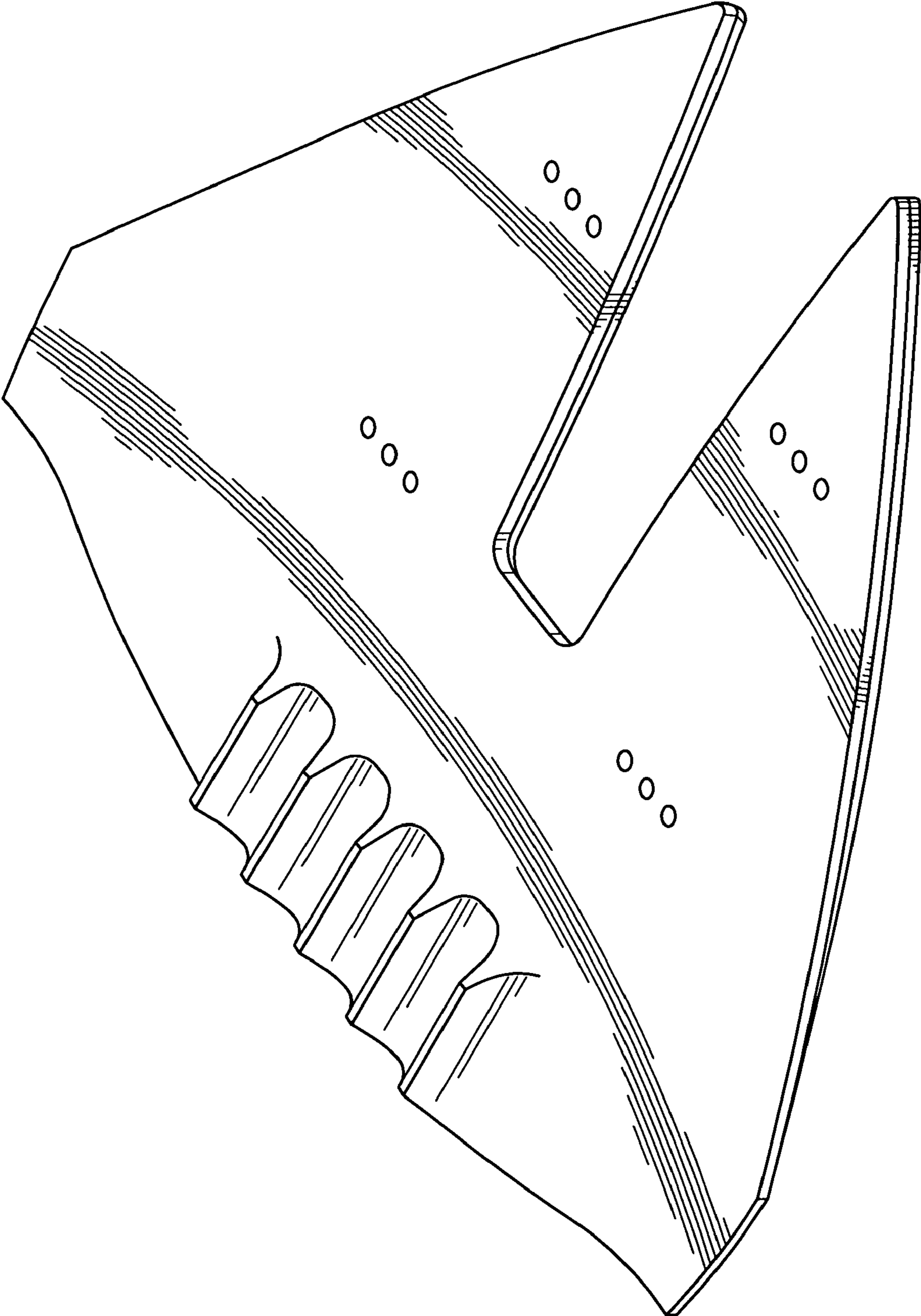

FIG. 18

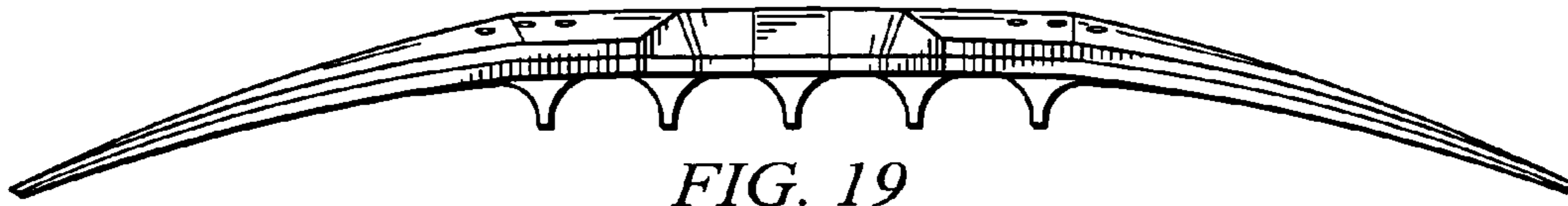

FIG. 19

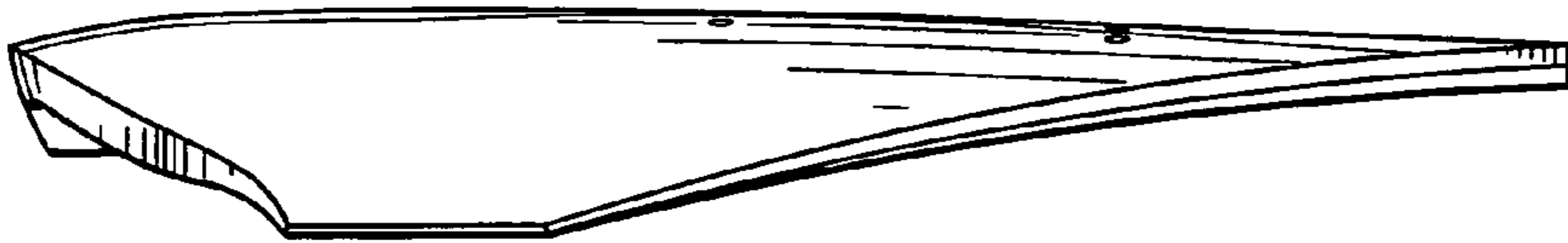

FIG. 20



FIG. 21

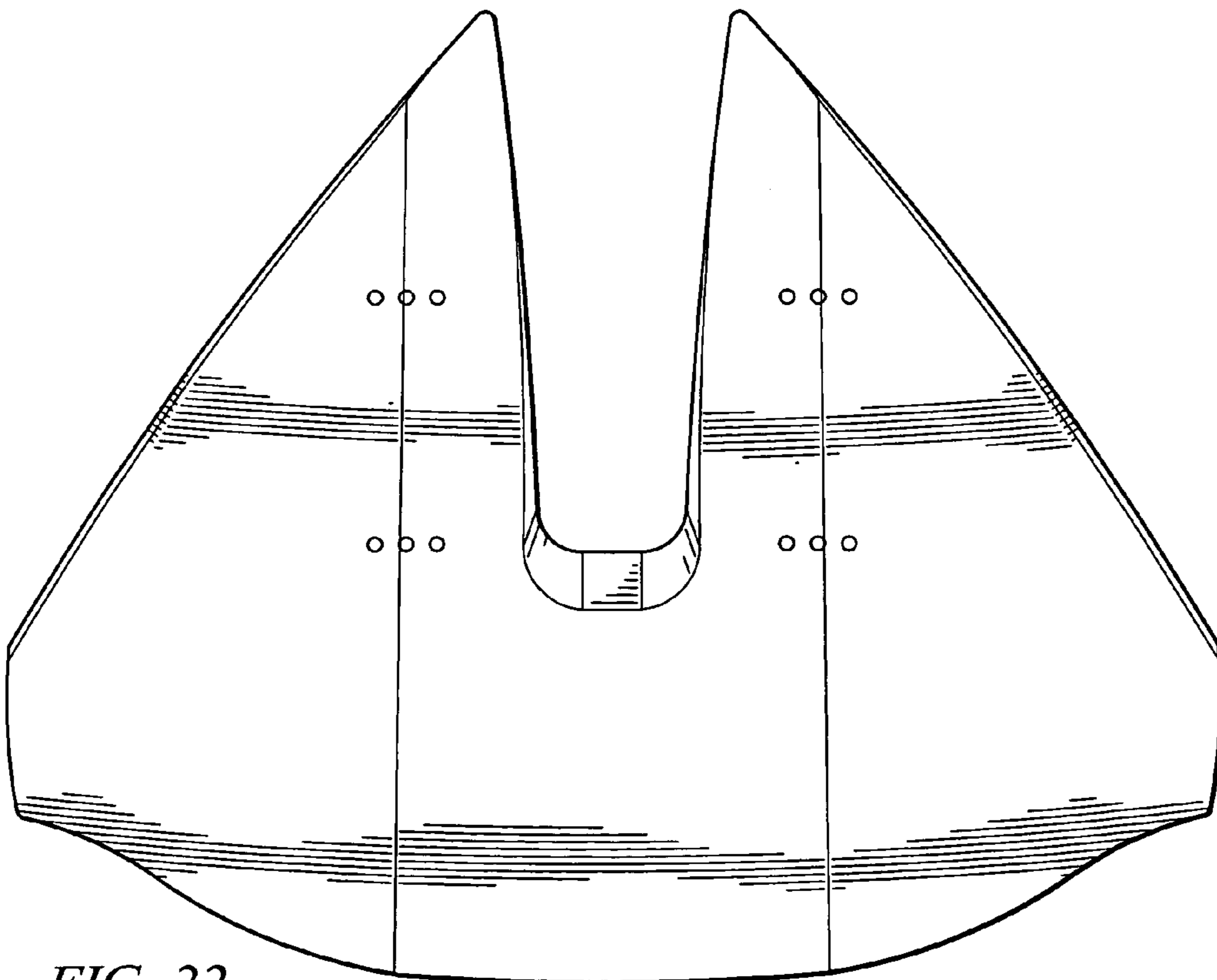

FIG. 22

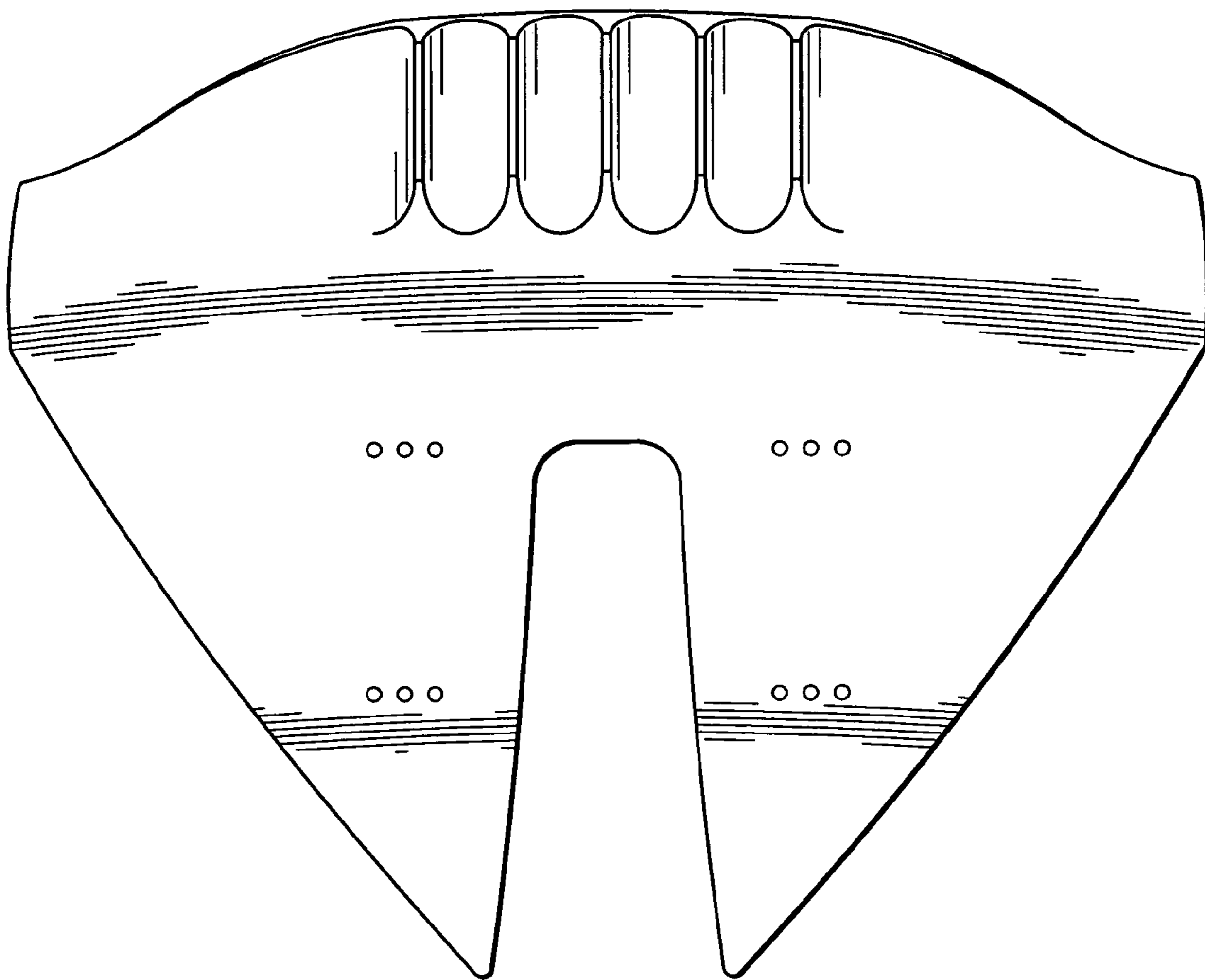

FIG. 23