



US00D615301S

(12) **United States Design Patent**  
**Gracer et al.**

(10) **Patent No.:** **US D615,301 S**

(45) **Date of Patent:** **\*\* May 11, 2010**

(54) **COMPUTER CASE**

(75) Inventors: **Zoran Gracer**, Deerfield, IL (US);  
**Donald E. Godshaw**, Wilmette, IL (US)

(73) Assignee: **Travel Caddy, Inc.**, Elk Grove Village,  
IL (US)

(\*\*) Term: **14 Years**

(21) Appl. No.: **29/323,657**

(22) Filed: **Aug. 28, 2008**

(51) **LOC (9) Cl.** ..... **03-01**

(52) **U.S. Cl.** ..... **D3/319**

(58) **Field of Classification Search** ..... D3/319,  
D3/203.1, 233, 273–274, 276, 900; 150/113;  
190/100, 102, 110, 900

See application file for complete search history.

(56) **References Cited**

**U.S. PATENT DOCUMENTS**

1,755,548	A	4/1930	Lowe
2,707,035	A	4/1955	Lashley
3,081,807	A	3/1963	Lightburn
3,351,064	A	11/1967	Dohn

(Continued)

**FOREIGN PATENT DOCUMENTS**

EP 0702911 3/1996

(Continued)

**OTHER PUBLICATIONS**

Checkable Case, Model No. 3311, Retrieved from <http://www.brenthaven.com/catalog-checkable-case.html> on Jan. 20, 2009.

(Continued)

*Primary Examiner*—Holly H Baynham

*Assistant Examiner*—Sheryl Lane

(74) *Attorney, Agent, or Firm*—Fitch, Even, Tabin & Flannery

(57) **CLAIM**

The ornamental design for a computer case, as shown and described.

**DESCRIPTION**

FIG. 1 is an isometric view of an embodiment of the computer case of the invention positioned within a carrying case depicted in phantom;

FIG. 2 is an isometric view of the embodiment of FIG. 1 removed from the carrying case and including a fabric sheet linking the computer case to the carrying case;

FIG. 3 is a front lateral side elevation of the computer case of FIG. 2 with a see-through mesh side panel;

FIG. 4 is a bottom side view of the computer case of FIG. 1;

FIG. 5 is a top side view of the computer case of FIG. 2;

FIG. 6 is a back lateral side elevation of the computer case of FIG. 2;

FIG. 7 is a right hand side elevation of the computer case of FIG. 2;

FIG. 8 is a left hand side elevation of the computer case of FIG. 2; and,

FIG. 9 is an isometric view of an alternative design of the computer case of the invention wherein a fabric sheet for linking the computer case to a carrying case (in phantom) and the handle for the computer case have been reversed from the embodiment of FIG. 2.

The broken lines on the fabric sheet are intended to be stitching and are part of the claimed design.

**1 Claim, 5 Drawing Sheets**

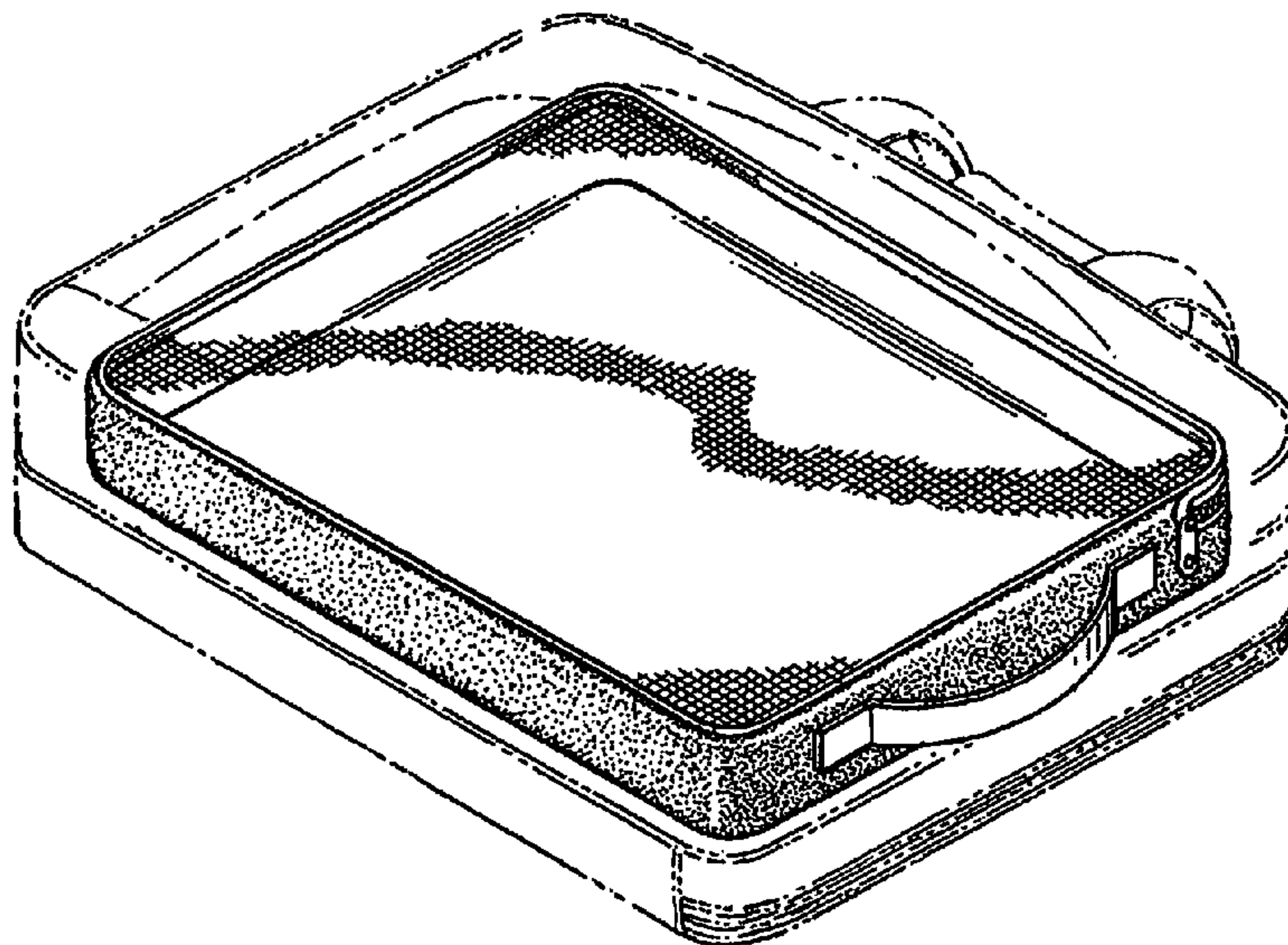



U.S. PATENT DOCUMENTS

3,370,629	A	2/1968	Neuman	
3,741,355	A	6/1973	Slan	
3,807,537	A	4/1974	O'Reilly	
3,870,132	A	3/1975	Hanley	
4,524,867	A	6/1985	Klein et al.	
4,580,667	A	4/1986	Herwood	
D284,527	S	7/1986	Davis	
4,669,587	A	6/1987	Zitt	
4,685,570	A	8/1987	Medow	
4,716,947	A	1/1988	Haddock	
4,913,283	A	4/1990	Stuhn	
D323,743	S	2/1992	Disessa et al.	
D324,453	S	3/1992	Disessa et al.	
5,149,202	A	9/1992	Dickert	
D335,030	S	4/1993	Alfonso	
D338,104	S	8/1993	Lee	
5,255,833	A	10/1993	McAllister	
D344,074	S	2/1994	Collins	
D346,901	S	5/1994	Dulka et al.	
5,354,131	A	10/1994	Mogil	
D354,399	S *	1/1995	Georges	D3/319
5,377,794	A	1/1995	Book	
5,395,023	A	3/1995	Naymark et al.	
D358,483	S	5/1995	Cross et al.	
D360,075	S	7/1995	Cross et al.	
5,445,266	A	8/1995	Prete et al.	
D367,166	S	2/1996	Hettenbach	
5,607,054	A	3/1997	Hollingsworth	
D380,612	S	7/1997	Kelley et al.	
5,797,529	A	8/1998	Lavine	
5,862,526	A	1/1999	Longcor et al.	
5,887,723	A	3/1999	Myles et al.	
D408,146	S *	4/1999	Briganti	D3/319
5,908,147	A *	6/1999	Chuang	224/607
6,000,509	A	12/1999	Chisholm	
6,012,557	A	1/2000	Derelanko	
D437,115	S	2/2001	Hillman	
6,183,133	B1 *	2/2001	Roegner	383/39
6,296,094	B1	10/2001	Knecht	
6,318,552	B1	11/2001	Godshaw	
D458,749	S *	6/2002	Bruni et al.	D3/289
6,460,668	B1	10/2002	Godshaw et al.	
6,568,852	B1 *	5/2003	Godshaw et al.	383/2
6,604,618	B1	8/2003	Godshaw et al.	
6,637,563	B1	10/2003	Ruckh	
D500,597	S	1/2005	Hillman	
D529,717	S *	10/2006	Branchy	D3/285
D548,967	S	8/2007	Bell	
D560,361	S *	1/2008	Huang	D3/301
D581,669	S	12/2008	Sween et al.	
2001/0054569	A1	12/2001	Bisbal et al.	
2003/0192759	A1	10/2003	Godshaw et al.	
2006/0042896	A1	3/2006	Godshaw et al.	
2006/0049016	A1	3/2006	Godshaw et al.	

FOREIGN PATENT DOCUMENTS

FR	2535955	5/1984
WO	9632860	10/1996
WO	9906292	2/1999

OTHER PUBLICATIONS

Slim Computer Brief, No. BB101; Organized Computer Brief, No. BB102; Mini Computer Brief No. BB103; Expandable Overnighter Computer Brief, No. BB104X; Vertical Computer Brief/Backpack, No. BB107; Computer Messenger Bag, No. BB109; Ultimate Organized Computer Brief, No. BB123; Ultimate Big Screen Computer Brief, No. BB140; Leather Slim Computer Brief, No. LB101; Leather Organized Computer Brief, No. LB102; Compact Rolling Computer Case, No. BR214; Retrieved from [http://www.briggs-riley.com/checkpoint\\_friendly.asp](http://www.briggs-riley.com/checkpoint_friendly.asp); Retrieved on Jan. 20, 2009.

Leather Expandable Overnight Computer Brief, No. LB104X; Go Messenger Bag, No. VB410; Rolling Expandable Computer Case, No. BR212X; Ultimate Rolling Organized Computer Case No. BR222; Rolling Big Screen Computer Case, No. BR260; 13" Speedthru Computer Sleeve, No. BB901; 15.4" SpeedThru Computer Sleeve, No. BB902; 17" SpeedThru Computer Sleeve, No. PP903; Retrieved from [http://www.briggs-riley.com/checkpoint\\_friendly.asp](http://www.briggs-riley.com/checkpoint_friendly.asp); Retrieved on Jan. 20, 2009.

15.4" SpeedThru Briefcase No. BB922; 17" SpeedThru Computer Sleeve, No. BB924; Sonic 15.4" SpeedThru Computer Sleeve, No. VB903; Sonic 17" SpeedThru Computer Sleeve, No. VB904; Fuse 20" Carry-On Computer Upright, No. VB420C; Retrieved from [http://www.briggs-riley.com/checkpoint\\_friendly.asp](http://www.briggs-riley.com/checkpoint_friendly.asp); Retrieved on Jan. 20, 2009.

ScanFast Checkpoint Friendly Messenger Bag, No. MESFMB; ScanFast Checkpoint Friendly Briefcase, No. MESFBC; Scan Fast Checkpoint Friendly Backpack No. MESFBP; ScanFast Element Checkpoint Friendly Briefcase, No. MESFEB8; Retrieved from <http://www.modileedge.com/scanfast>; Retrieved on Jan. 20, 2009.

ScanFast Element Checkpoint Friendly Briefcase, No. MESFEB9; ScanFast Element Checkpoint Friendly Briefcase, No. MESFEBX; ScanFast Onyx Checkpoint Friendly Briefcase, No. MESFOBC; ScanFast Onyx Checkpoint Friendly Backpack, No. MESFOBP; Retrieved from <http://www.mobileedge.com/scanfast>; Retrieved on Jan. 20, 2009.

Checkthrough Messenger; Checkthrough Brief; DUY Skin; Skooba Skin Micro; Skooba Skin 1012; Skooba Skin 1415; Skooba Skin 1617; Retrieved from <http://www.skoobadesign.com/catalog/checkpoint-friendly-bags-288/?ocCsId=5357180038da16e81600b157035d653c>; Retrieved on Jan. 20, 2009.

15.4" Smart Strap Laptop Portfolio Stule DSGL500-4; AlwaysOn CheckFast Sleeve, Style CLA101-4; CheckFast Laptop Clamshell, Style CLA310-4; AlwaysOn CheckFast Sleeve, Style TCB101-4; AlwaysOn CheckFast Sleeve, Style TCB102-4; CheckFast Laptop Clamshell, Style TCB310-4; Retrieved from <http://www.solocases.com/cat.aspx?id=7>; Retrieved on Jan. 20, 2009.

Targus Zip-Thru 15.4" Corporate Traveler Laptop Case, Item CUCT02UA15S; Targus Zip-Thru 15.4" Air Traveler Laptop Case, Item TBT04401US; Targus Zip-Thru 15.4" Air Traveler Laptop Case, Item TBT044US; Targus Zip-Thru 17" Air Traveler Laptop Case, Item TBT046US; Retrieved from [http://www.targus.com/us/cases\\_laptop\\_zipthru.asp?utm\\_source=targus&utm\\_medium=direct&utm\\_content=homepage&utm\\_campaign=zipthru](http://www.targus.com/us/cases_laptop_zipthru.asp?utm_source=targus&utm_medium=direct&utm_content=homepage&utm_campaign=zipthru); Retrieved on Jan. 20, 2009.

Targus Zip-Thru 15.4" Modile Elite Laptop Case, Item TBT045US; Targus Zip-Thru 15.4" Traditional Laptop Case, Item TBC023US; Retrieved from [http://www.targus.com/us/cases\\_laptop\\_zipthru.asp](http://www.targus.com/us/cases_laptop_zipthru.asp) [utm\\_source=targus&utm\\_medium=direct&utm\\_content=homepage&utm\\_campaign=zipthru](http://www.targus.com/us/cases_laptop_zipthru.asp?utm_source=targus&utm_medium=direct&utm_content=homepage&utm_campaign=zipthru); Retrieved on Jan. 20, 2009.

Checkpoint Flyer; Retrieved from <http://www.tombihn.com/page/001/PROD/TBP/TB1701>; Retrieved on Jan. 20, 2009.

VertiGo; Retrieved from <http://sfbags.com/products/vertigo/vertigo.htm>; Retrieved on Jan. 20, 2009.

CheckPoint Friendly CompuBrief, No. 1014; Wheeled Checkpoint Friendly CompuBrief, No. 1018; Retrieved from [http://www.pathfinderluggage.com/link\\_products/checkpointfriendly.html](http://www.pathfinderluggage.com/link_products/checkpointfriendly.html); Retrieved on Jan. 20, 2009.

TurboBag T-250 Checkpoint Friendly Laptop Bag; Retrieved from <http://www.turbobag.com>; Retrieved on Jan. 20, 2009.

Aerovation CPF Laptop Bag; Retrieved from <http://www.aerovation.com>; Retrieved on Jan. 20, 2009.

CODi Phantom CT3 Checkpoint Tested Laptop Bag; Retrieved from [http://www.ebags.com/codi/brand\\_search/index.cfm?brandid=10609](http://www.ebags.com/codi/brand_search/index.cfm?brandid=10609); Retrieved on Jan. 20, 2009.

QuickCheck "Check Point Friendly" Notebook Carrying Case for MacBook Air, Item No. MACBOOK\_AIR\_IM-200; Retrieved from [http://www.myincipio.com/product/MACBOOK\\_AIR\\_IM=200QuickCheck\\_Check\\_Point\\_Friendly\\_Laptop\\_Carrying\\_Case.html](http://www.myincipio.com/product/MACBOOK_AIR_IM=200QuickCheck_Check_Point_Friendly_Laptop_Carrying_Case.html); Retrieved on Jan. 20, 2009.

U.S. Appl. No. 29/328,239, filed Nov. 20, 2008, entitled "Computer Protection and Carrying Case".

Brenthaven-Zero Impact product brochure, Checkable Case Laptop Shoulder Case, 2008, Brenthaven Corporation, available at <http://www.brenthaven.com/catalog-checkable-case.html>.

\* cited by examiner

FIG. 1

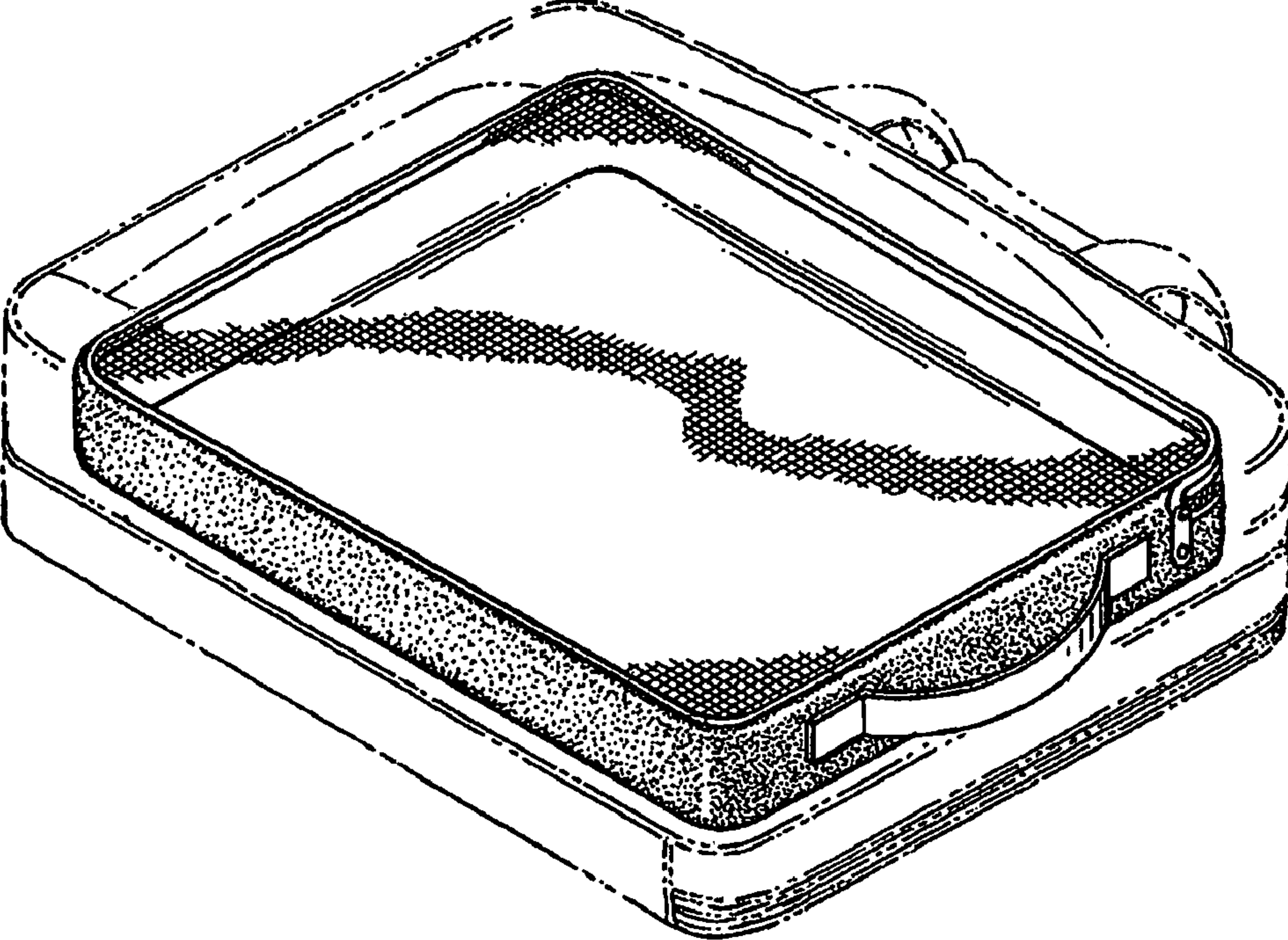
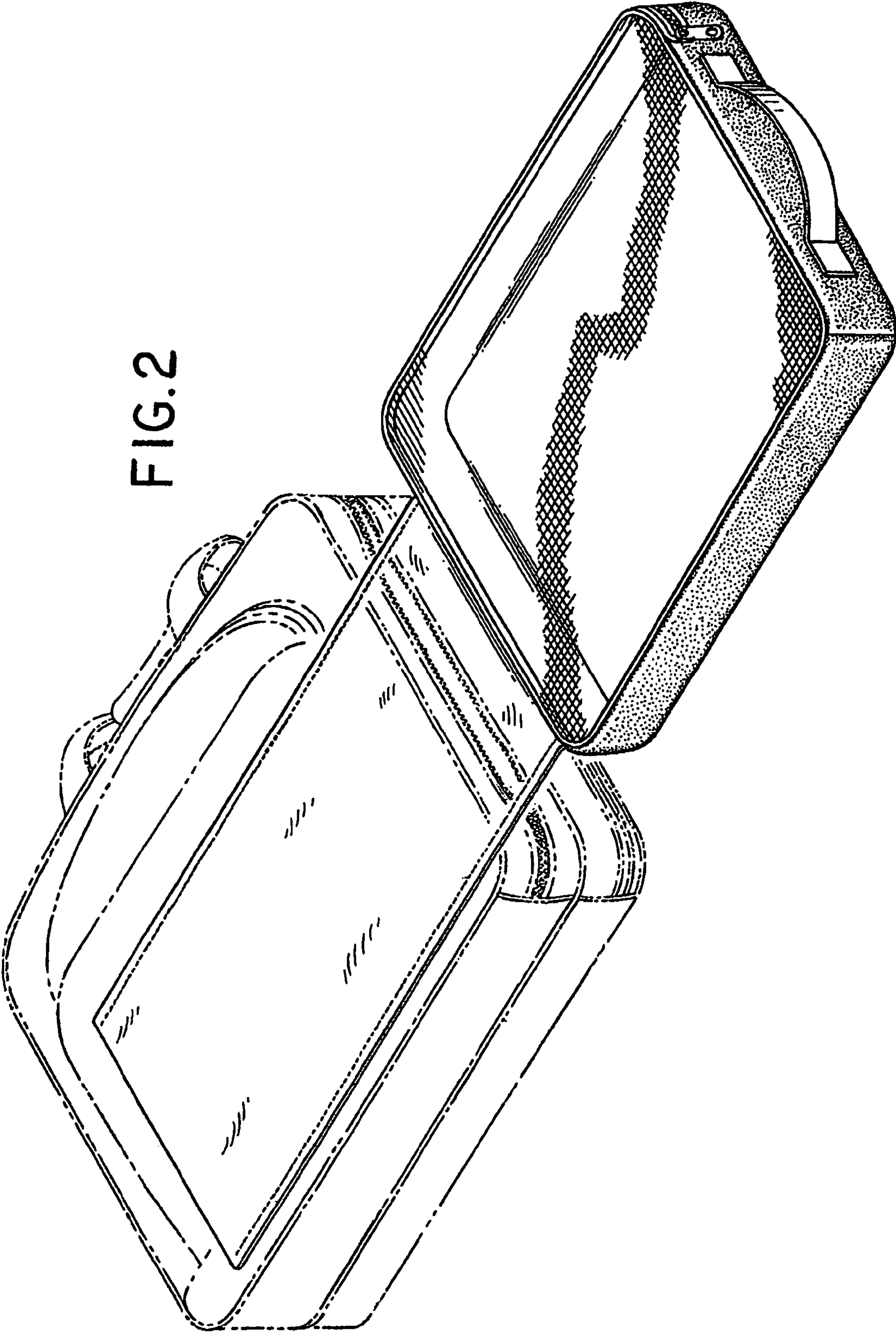



FIG.2



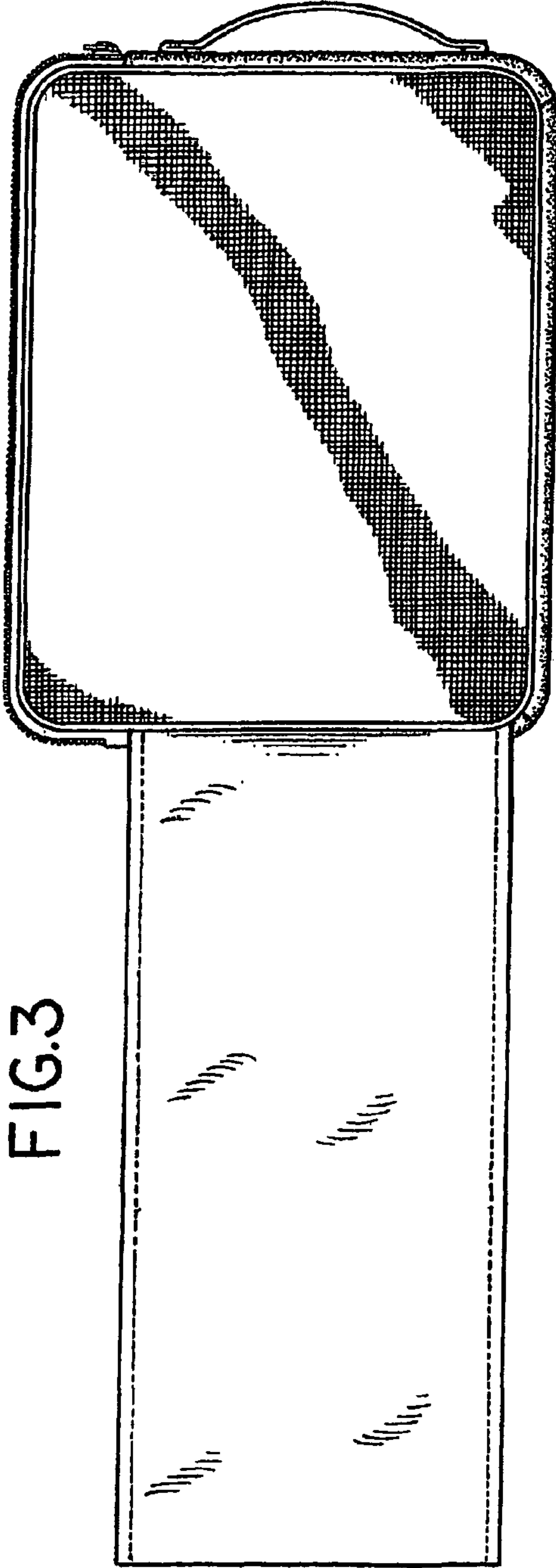

FIG.3



FIG.4

FIG.5

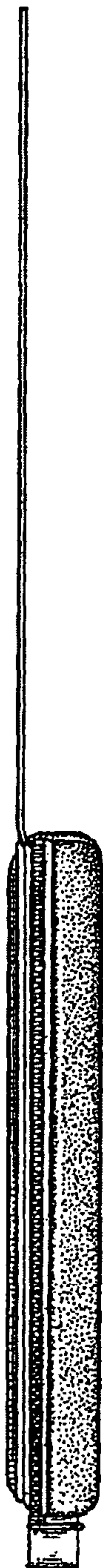

FIG.6

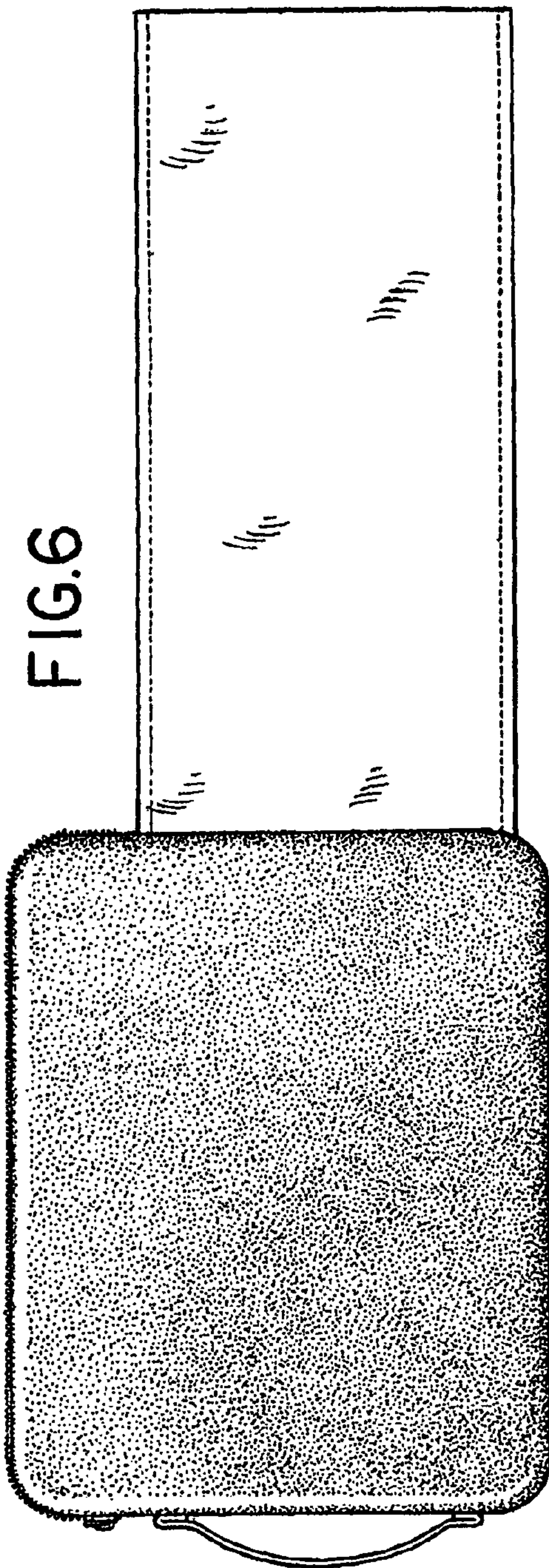

FIG.8

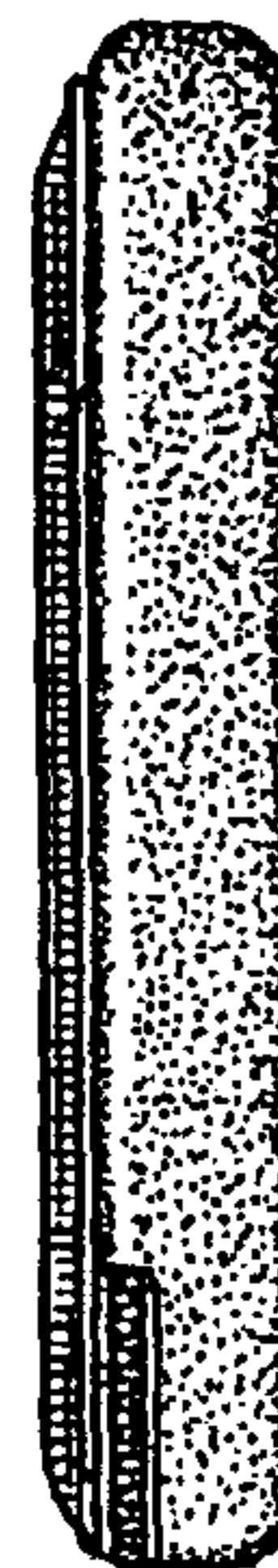
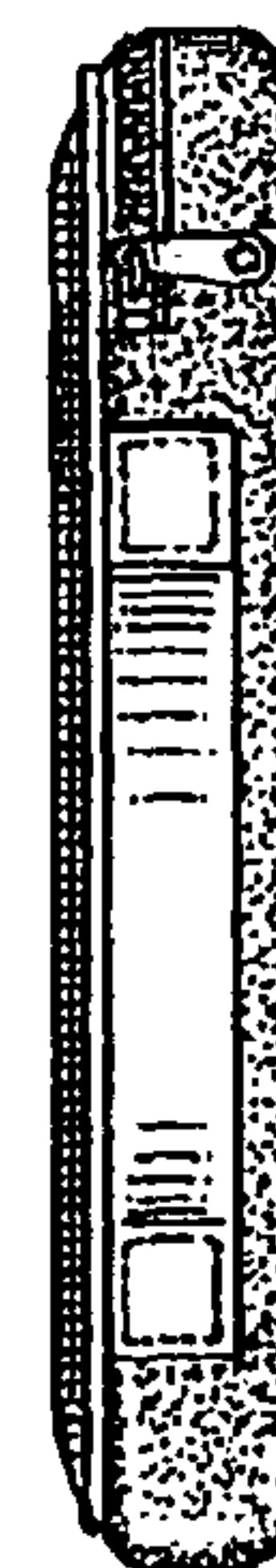

FIG.7





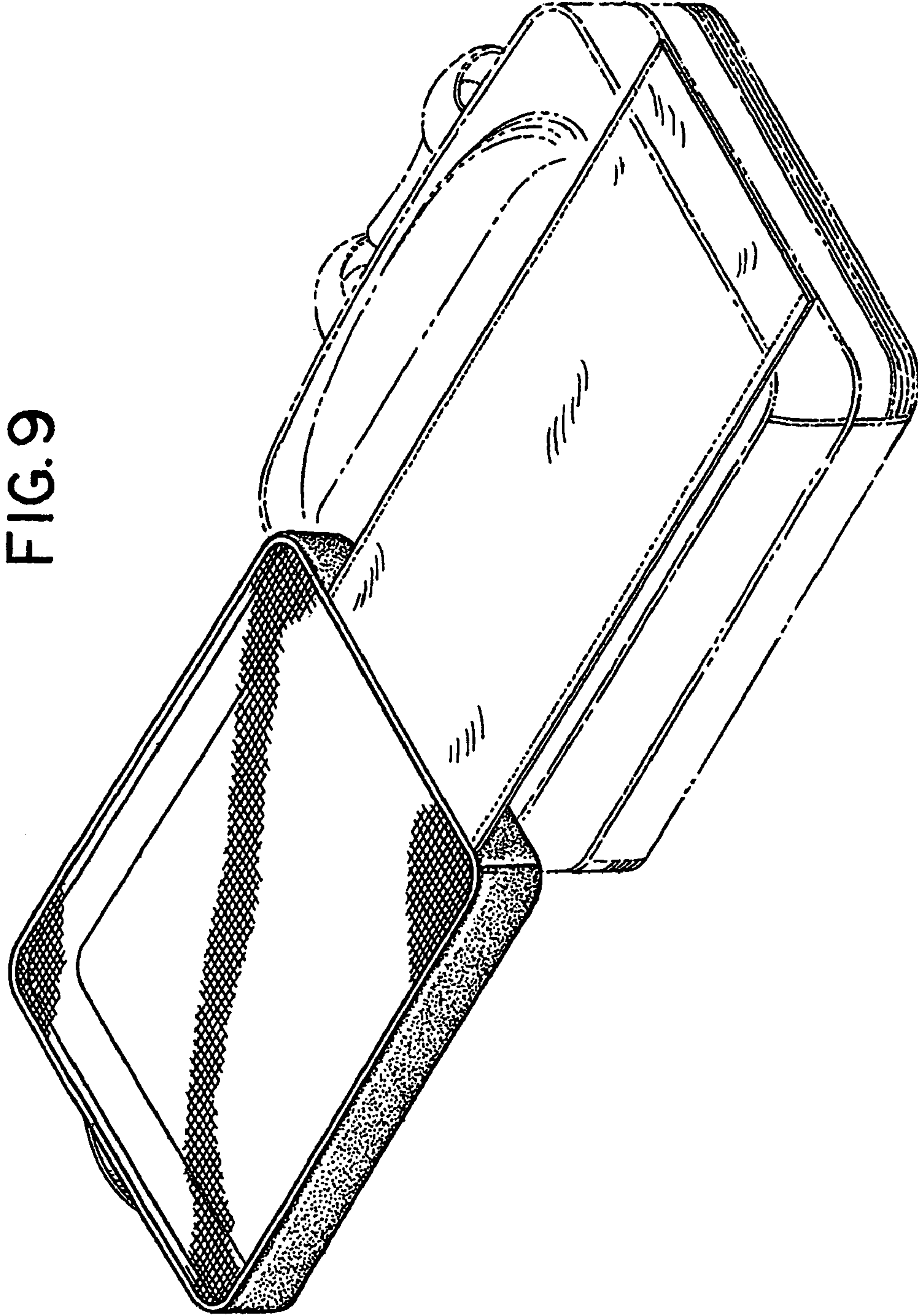

FIG. 9