

US00D615224S

(12) **United States Design Patent**
Woolley et al.

(10) **Patent No.:** **US D615,224 S**

(45) **Date of Patent:** **** May 4, 2010**

(54) **VEHICLE TAILLIGHT**

(75) Inventors: **Richard Woolley**, West Midlands (GB);
Earl Lucas, Southfield, MI (US); **Dean Carbis**,
Birmingham, MI (US); **Dong Park**, Royal Oak, MI (US);
Michael Boyd, Detroit, MI (US)

(73) Assignee: **Ford Motor Company**, Dearborn, MI (US)

(**) Term: **14 Years**

(21) Appl. No.: **29/350,083**

(22) Filed: **Nov. 11, 2009**

(51) **LOC (9) Cl.** **26-06**

(52) **U.S. Cl.** **D26/28**

(58) **Field of Classification Search** D26/28-36;
362/459-468, 475-478, 485-487

See application file for complete search history.

(56) **References Cited**

U.S. PATENT DOCUMENTS

D549,363 S *	8/2007	Pfeiffer	D26/28
D552,769 S *	10/2007	Leclercq	D26/28
D553,268 S *	10/2007	Pfeiffer	D26/28
D553,269 S *	10/2007	Pfeiffer et al.	D26/28
D560,292 S *	1/2008	Sato	D26/28
D561,357 S *	2/2008	Leclercq	D26/28
D562,998 S	2/2008	Golden et al.		
D570,015 S *	5/2008	Hsu	D26/28
D574,524 S *	8/2008	Tomatsu	D26/28

OTHER PUBLICATIONS

Paris 2006 Mondeo Break Concept <http://www.a2mac1.net>.
Beijing 2008 Motor Show Ford Mondeo <http://www.a2mac1.net>.

Detroit 2008 Auto Show Verve Concept <http://222.a2mac1.net>.
<http://www.autoblog.com>; Apr. 9, 2008 spy-shots-2010-aurus-finally/.

* cited by examiner

Primary Examiner—Marcus A Jackson
(74) *Attorney, Agent, or Firm*—Damian Porcari

(57) **CLAIM**

An ornamental design for a vehicle taillight, shown and described.

DESCRIPTION

FIG. 1 is a left side elevational view of a left vehicle taillight (the right vehicle taillight being a mirror image and is not shown);

FIG. 2 is right side elevational view of the vehicle taillight;

FIG. 3 is a front elevational view of the vehicle taillight;

FIG. 4 is a rear elevational view of the vehicle taillight;

FIG. 5 is a top plan view of the vehicle taillight;

FIG. 6 is a bottom plan view of the vehicle taillight; and,

FIG. 7 is a perspective view of the vehicle taillight.

The absence or presence of surfaces on the area enclosed by broken lines is not relied upon for patentability or infringement. The surfaces enclosed by broken lines are illustrated in lighter tones to distinguish them from the claimed surfaces. Any broken lines represent an internal boundary of the design; the line itself and the area within form no part of the claim. Views are orthogonal projections rendered from computer aided design data. The vehicle taillight is intended to be observed in various states of internal illumination as well as in daylight with no internal illumination.

1 Claim, 7 Drawing Sheets

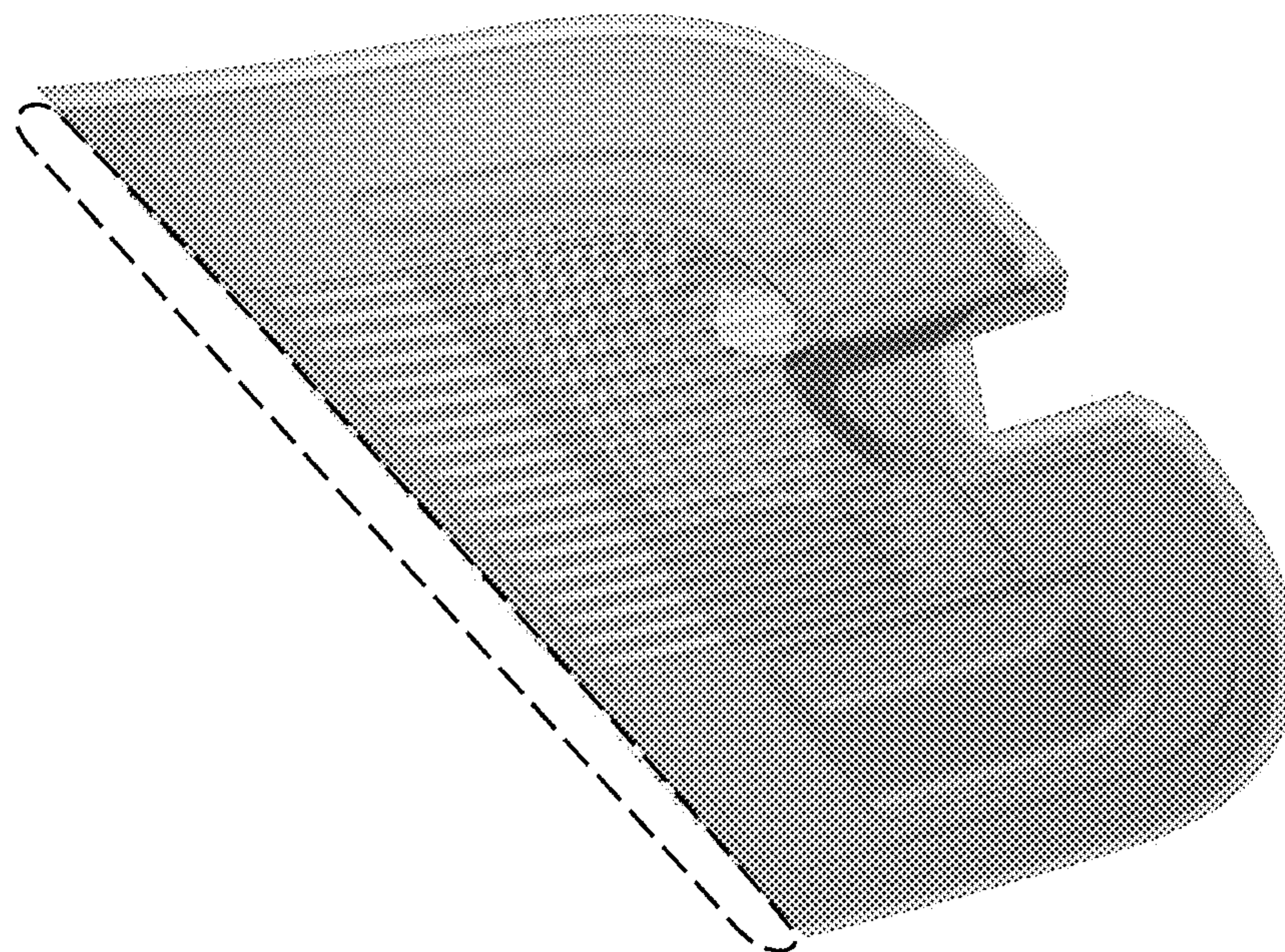
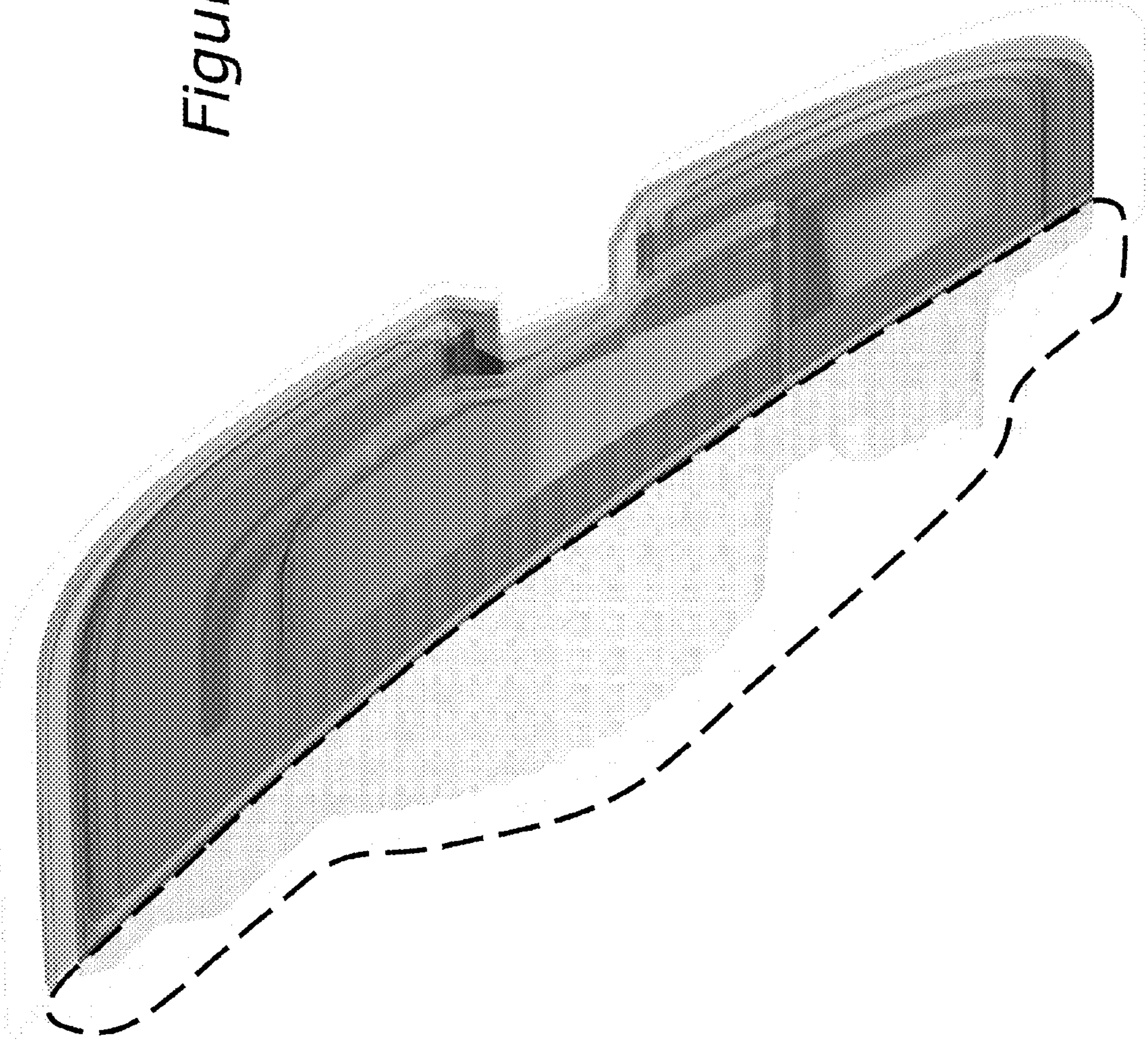

Figure 1



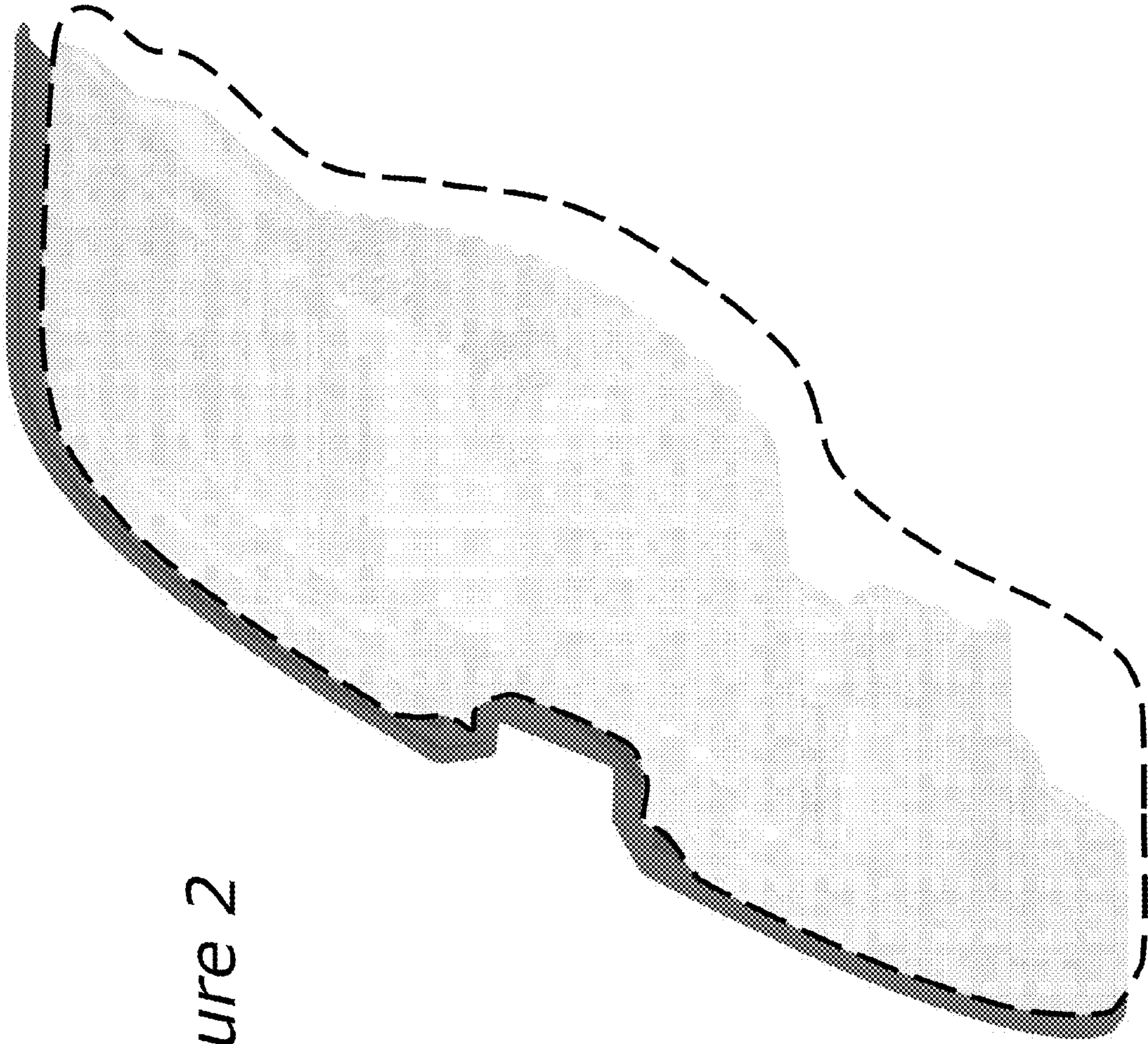
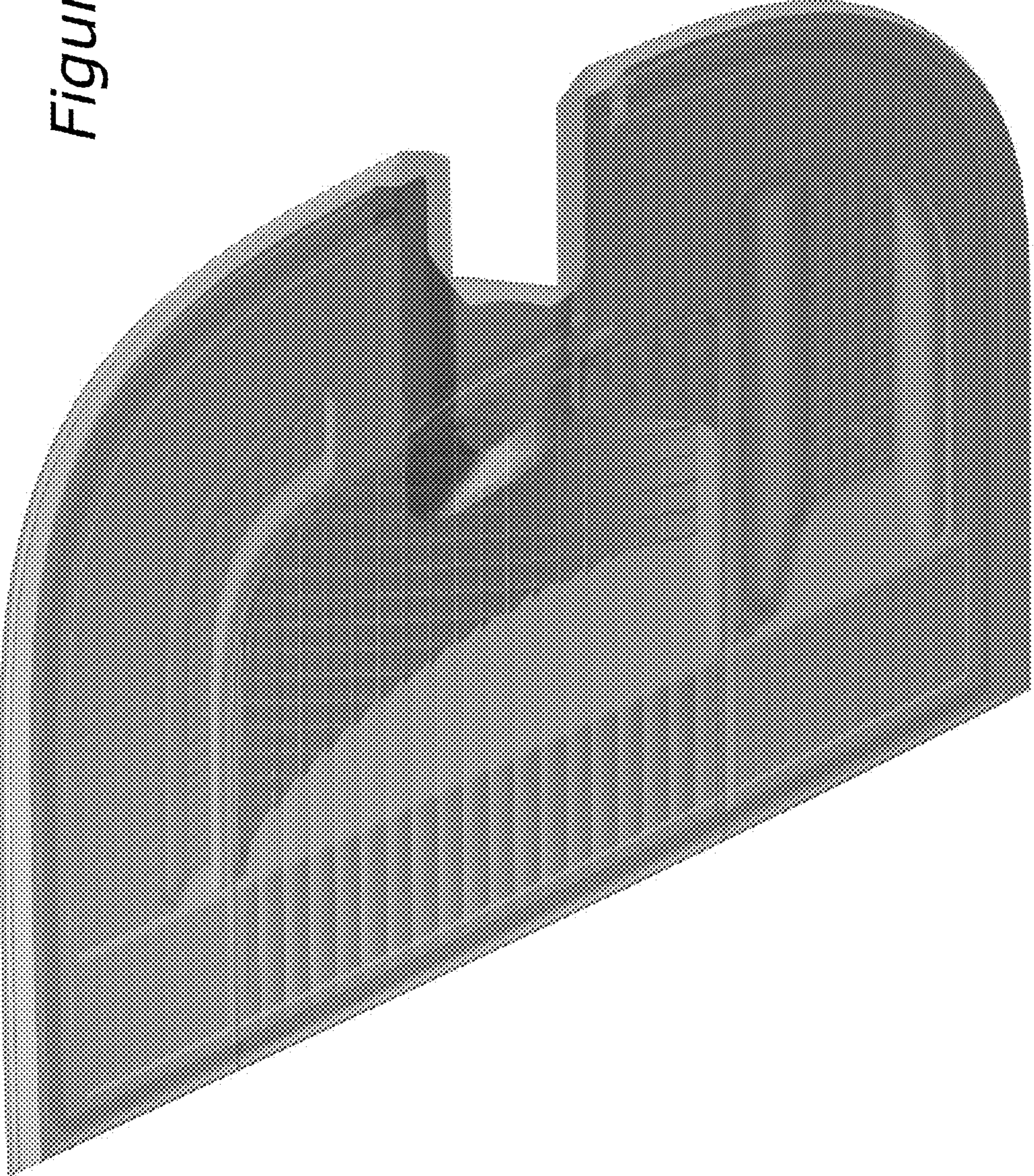

Figure 2

Figure 3



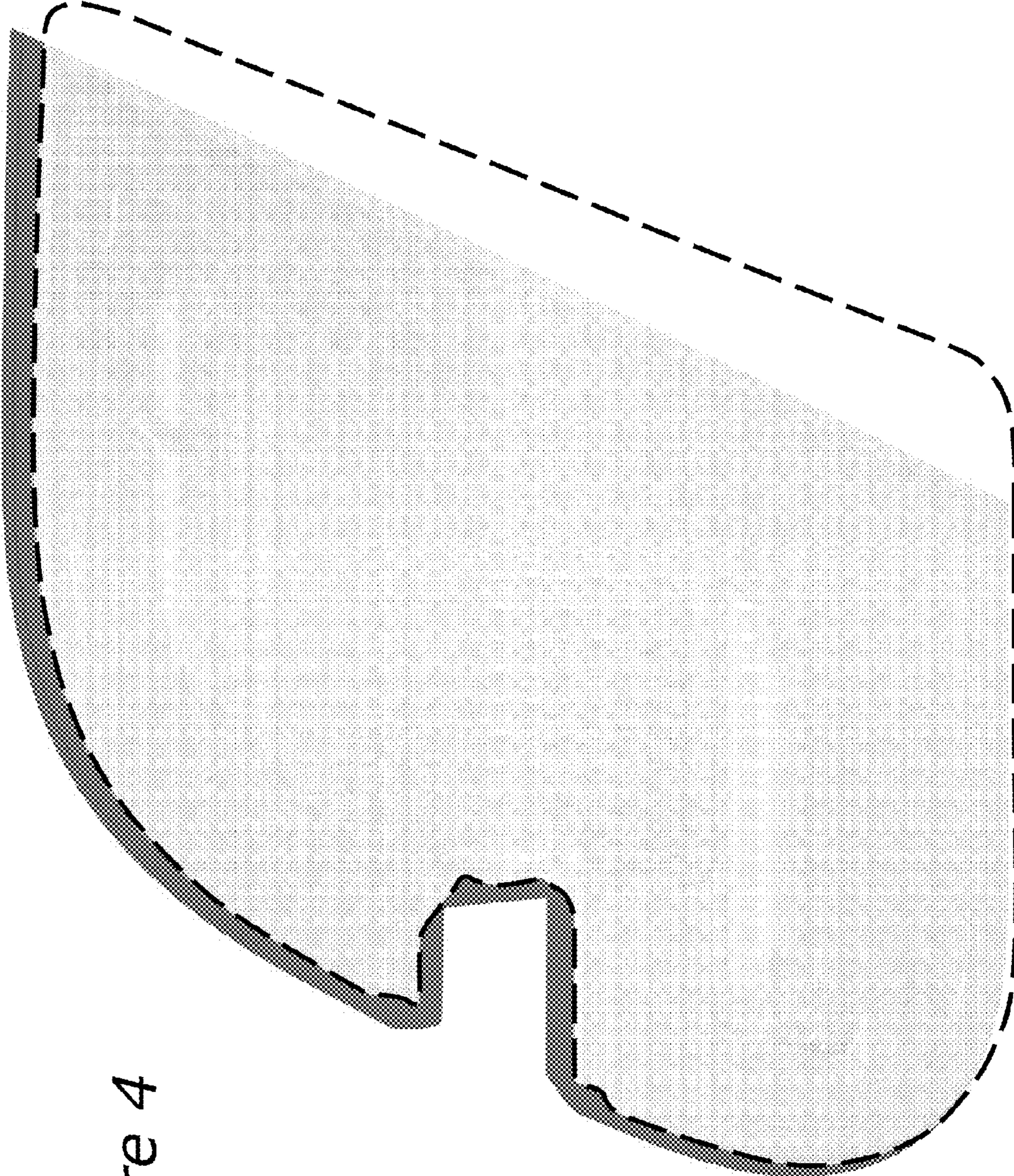

Figure 4

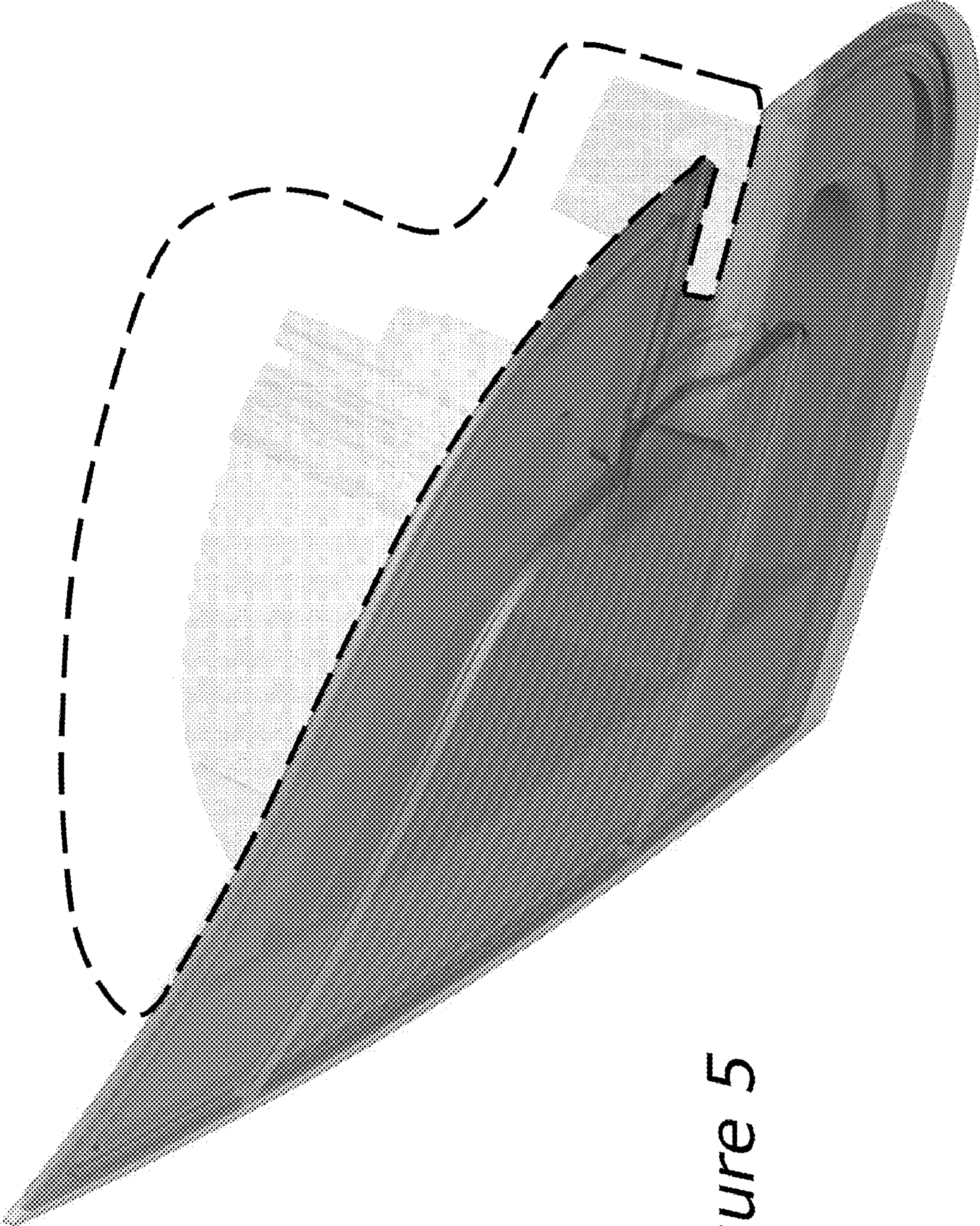

Figure 5

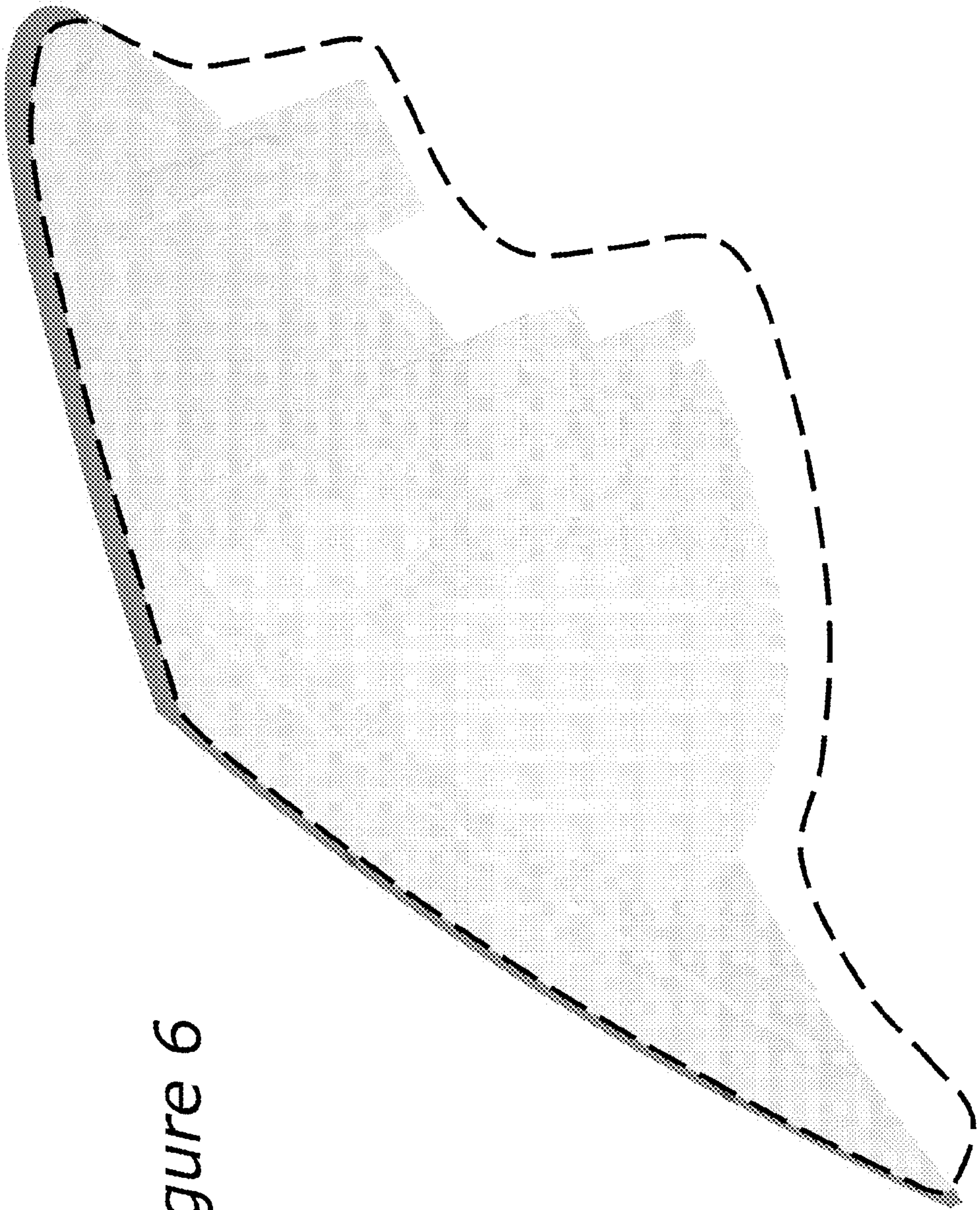

Figure 6

Figure 7

