



US00D615149S

(12) **United States Design Patent**  
**Reid et al.**

(10) **Patent No.:** **US D615,149 S**  
(45) **Date of Patent:** **\*\* May 4, 2010**

(54) **FILTER BLOCK FOR LIQUID FILTRATION**

(75) Inventors: **Roger P. Reid**, Caldwell, ID (US);  
**Bruce D Saaski**, Nampa, ID (US)

(73) Assignee: **Omnipure Filter Company, Inc.**,  
Caldwell, ID (US)

(\*\*) Term: **14 Years**

(21) Appl. No.: **29/334,382**

(22) Filed: **Mar. 25, 2009**

**Related U.S. Application Data**

(63) Continuation-in-part of application No. 11/858,765,  
filed on Sep. 20, 2007.

(51) **LOC (9) Cl.** ..... **23-01**

(52) **U.S. Cl.** ..... **D23/209**

(58) **Field of Classification Search** ..... D23/207,  
D23/209; 210/282, 464

See application file for complete search history.

(56) **References Cited**

**U.S. PATENT DOCUMENTS**

532,939 A 1/1895 Balch  
(Continued)

**FOREIGN PATENT DOCUMENTS**

EP 0345381 12/1989  
(Continued)

**OTHER PUBLICATIONS**

Bear, Jacob, "Dynamics of Fluids in Porous Media", American Elsevier Publishing Company Inc., 1972, pp. 45-47.

*Primary Examiner*—Robin V Webster

(74) *Attorney, Agent, or Firm*—Pedersen & Co., PLLC; Ken J. Pedersen; Barbara S. Pedersen

(57) **CLAIM**

The ornamental design for a filter block for liquid filtration, as shown and described.

**DESCRIPTION**

FIG. 1 is a front perspective view of the invented design for a filter block for liquid filtration.

FIG. 2 is a front view of the filter block of FIG. 1, with the back view being the same as front view.

FIG. 3 is a side view of the filter block of FIG. 1, with right and left side views being the same.

FIG. 4 is a top view of the filter block of FIG. 1.

FIG. 5 is a bottom view of the filter block of FIG. 1.

FIG. 6 is a cross-sectional side view of the filter block of FIG. 1, taken along 6—6 in FIG. 4, the cross-section being taken axially front-to-back through the center of the filter block, and wherein stippling indicates the cut surface.

FIG. 7 is a cross-sectional, perspective side view of the filter block of FIG. 1, taken along 7—7 in FIG. 1, the cross-section being taken axially front-to-back through the center of the filter block, and, therefore, FIG. 7 being a perspective view of FIG. 6.

FIG. 8 is a cross-sectional, perspective front view of the filter block of FIG. 1, taken along 8—8 in FIG. 1, the cross-section being taken axially side-to-side through the middle of the filter block.

FIG. 9 is a front perspective view of an alternative embodiment of the invented design for a filter block for liquid filtration, having an axial rib.

FIG. 10 is a front view of the filter block of FIG. 9, with the back view being the same as front view.

FIG. 11 is a side view of the filter block of FIG. 9, with right and left side views being the same.

FIG. 12 is a top view of the filter block of FIG. 9.

FIG. 13 is a bottom view of the filter block of FIG. 9.

FIG. 14 is a cross-sectional, perspective front view of the filter block of FIG. 9, taken along 14—14 in FIG. 9, the cross-section being taken axially side-to-side through the center of the filter block, showing to best advantage the axial rib, and wherein stippling indicates the cut surface.

FIG. 15 is a cross-sectional, perspective right-side view of the filter block of FIG. 9, taken along 15—15 in FIG. 9, the cross-section being taken axially front-to-back through the center of the filter block; and,

FIG. 16 is a cross-sectional top view of the filter block of FIG. 9, taken along 16—16 in FIG. 11, the cross-section being taken radially front-to-back through the lower third of the filter block.

**1 Claim, 4 Drawing Sheets**

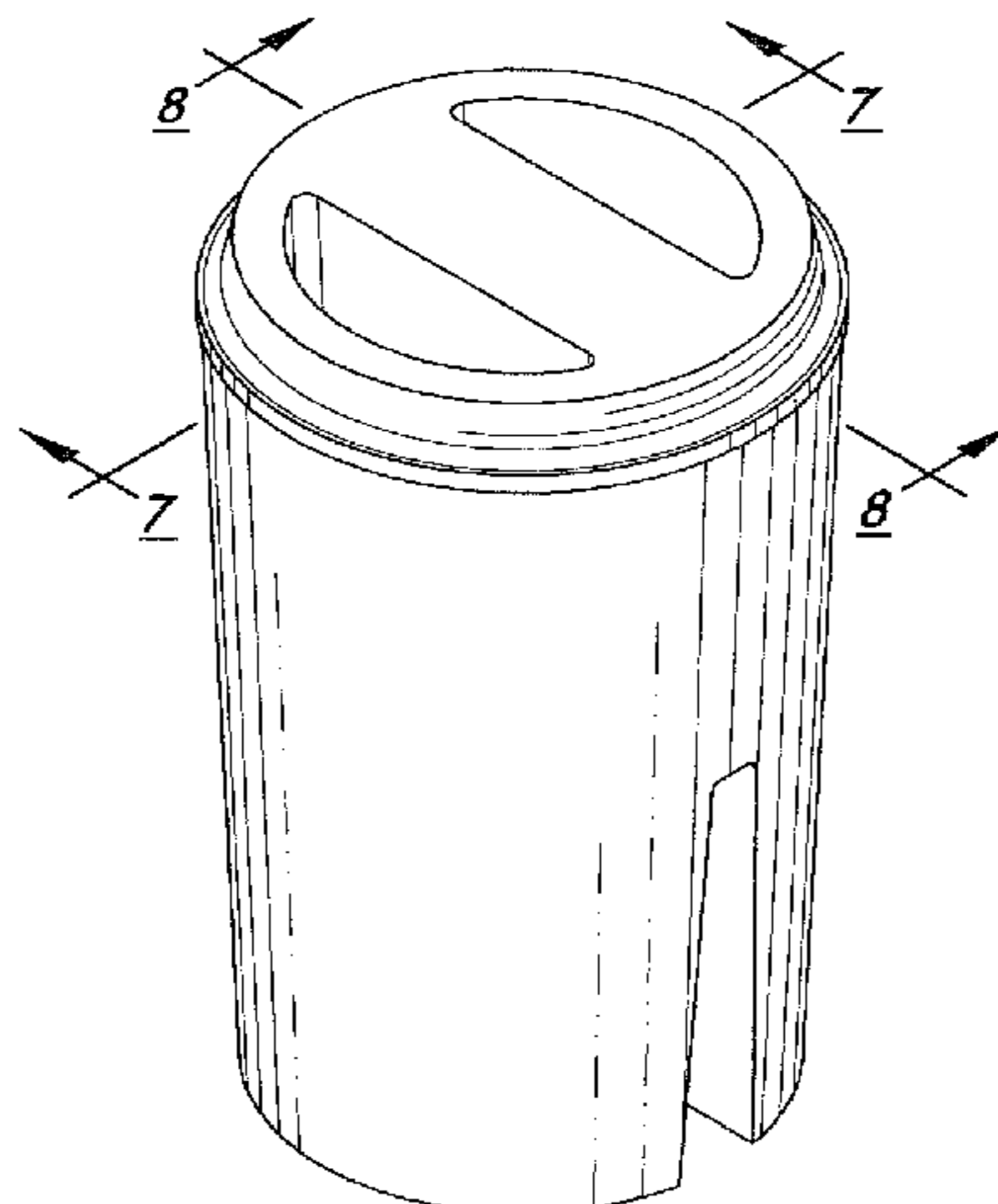

# US D615,149 S

Page 2

## U.S. PATENT DOCUMENTS

2,580,209	A	12/1951	Wiley	
2,720,278	A	10/1955	Wiley	
3,375,933	A	4/1968	Rodman	
3,538,020	A	11/1970	De Heskett et al.	
3,721,072	A	3/1973	Clapham	
3,746,642	A	7/1973	Bergstrom	
3,788,486	A	1/1974	Bergstrom	
4,306,971	A	12/1981	Hankammer	
4,664,683	A	5/1987	Degen et al.	
4,665,050	A	5/1987	Degen et al.	
4,666,600	A	5/1987	Hankammer	
4,753,728	A	6/1988	Vander Bilt et al.	
4,859,386	A	8/1989	Vanderbilt et al.	
4,895,648	A	1/1990	Hankammer	
4,969,996	A	11/1990	Hankammer	
4,980,073	A	12/1990	Woodruff	
5,017,318	A	5/1991	Vanderbilt et al.	
5,019,311	A	5/1991	Koslow	
5,024,764	A	6/1991	Ametek	
5,076,912	A	12/1991	Belz	
5,147,722	A	9/1992	Koslow	
5,189,092	A	2/1993	Koslow	
5,225,078	A	7/1993	Ametek	
5,256,285	A	10/1993	Tomita et al.	
5,344,558	A	9/1994	Kool	
5,352,274	A	10/1994	Blakley	
5,443,735	A	8/1995	Kirnbauer et al.	
5,486,285	A	1/1996	Feeney	
D380,535	S *	7/1997	Joergensen .....	D23/365
5,679,248	A	10/1997	Blaney	
D398,184	S	9/1998	Silverberg et al.	
D405,157	S	2/1999	Hayes et al.	
5,873,995	A	2/1999	Huang et al.	
5,922,803	A	7/1999	Koslow	
D415,922	S	11/1999	Kawasaki et al.	
D416,163	S	11/1999	Doritty et al.	
5,980,743	A	11/1999	Bairischer	
6,056,809	A	5/2000	Chapman	
6,074,550	A	6/2000	Hofmann et al.	
6,099,728	A	8/2000	Bairischer	
D435,084	S	12/2000	Northen et al.	
6,238,552	B1 *	5/2001	Shannon .....	210/94
RE37,216	E	6/2001	Koslow	
6,280,824	B1	8/2001	Insley et al.	
6,290,646	B1	9/2001	Cosentino et al.	
6,290,848	B1	9/2001	Tanner et al.	

6,322,615	B1	11/2001	Chapman	
6,368,504	B1	4/2002	Kuennen	
6,395,190	B1	5/2002	Koslow	
6,413,303	B2	7/2002	Gelderland et al.	
6,524,477	B1	2/2003	Hughes	
6,565,749	B1	5/2003	Hou	
6,638,426	B1	10/2003	Fritter et al.	
6,841,067	B1	1/2005	Hofmann et al.	
6,989,101	B2	1/2006	Cumberland et al.	
D529,127	S *	9/2006	Cueman .....	D23/209
7,169,466	B2	1/2007	Taylor et al.	
7,297,263	B2	11/2007	Nelson	
7,303,683	B2	12/2007	Cumberland	
7,378,015	B2	5/2008	Rinker et al.	
7,396,461	B2	7/2008	Bommi et al.	
D579,515	S	10/2008	Bell et al.	
2002/0005377	A1	1/2002	Tanner et al.	
2002/0062740	A1	5/2002	Brukov	
2002/0195407	A1	12/2002	Levy	
2003/0140785	A1	7/2003	Koslow	
2004/0195180	A1	10/2004	Cumberland et al.	
2004/0251190	A1	12/2004	Cumberland et al.	
2005/0072729	A1	4/2005	Bridges et al.	
2005/0172731	A1	8/2005	Anklin et al.	
2006/0021928	A1	2/2006	Nelson	
2006/0260997	A1	11/2006	Nelson	
2007/0215536	A1	9/2007	Bommi	
2008/0190827	A1	8/2008	Rinker	

## FOREIGN PATENT DOCUMENTS

EP	1354857	A4	10/2003
GB	2390987	A	1/2004
IN	320/MUMNP		8/2005
WO	WO 98/14265		4/1988
WO	WO 99/10076		3/1999
WO	WO 01/23306		4/2001
WO	WO 02/41970		5/2002
WO	WO 02/053262		7/2002
WO	WO 03/048693	A1	6/2003
WO	WO2004/000732	A1	12/2003
WO	WO 2005/094966	A1	10/2005
WO	WO2005/095284	A1	10/2005
WO	WO2006/037420	A1	4/2006
WO	WO2006/121932	A1	11/2006

\* cited by examiner

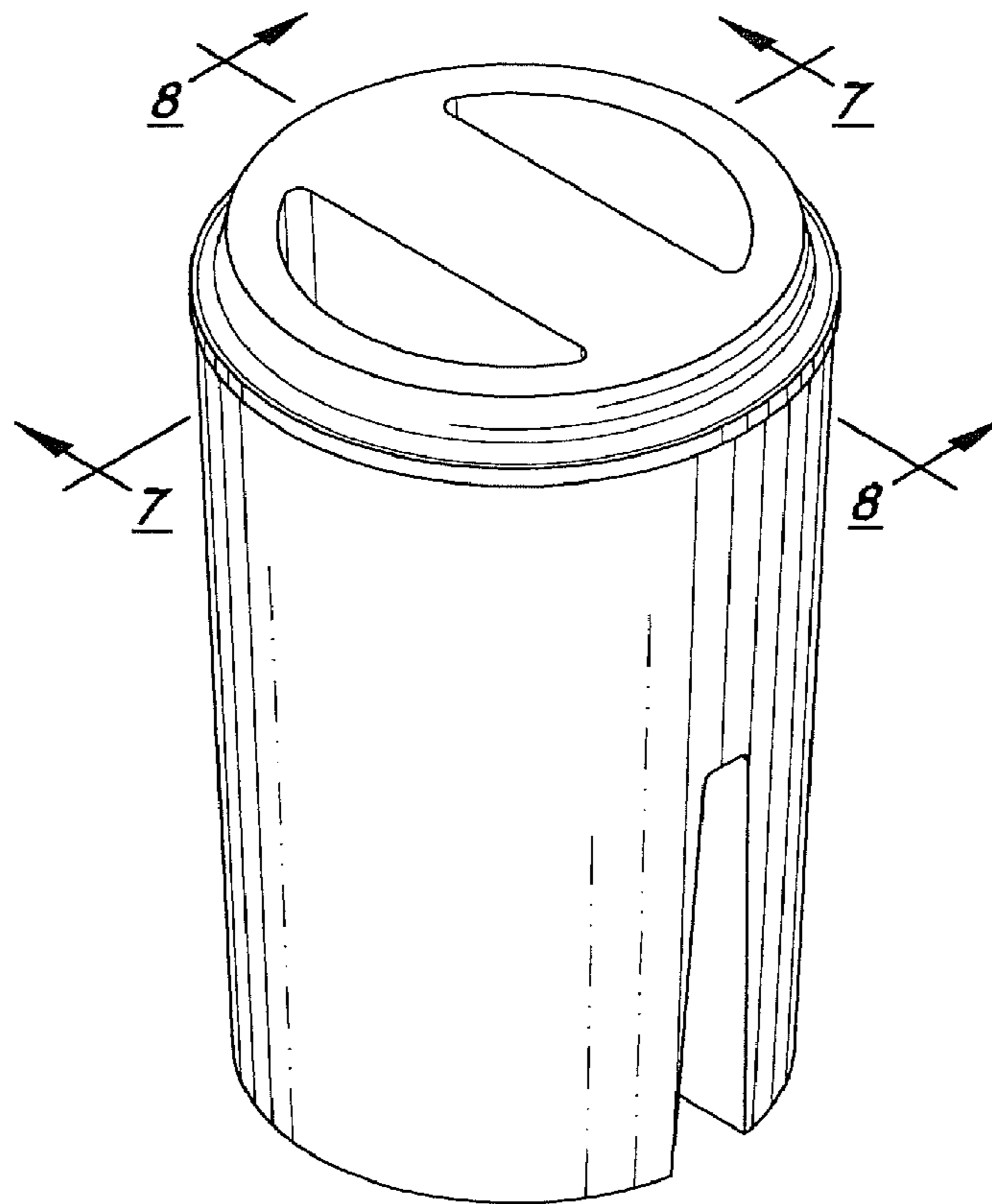

Fig. 1

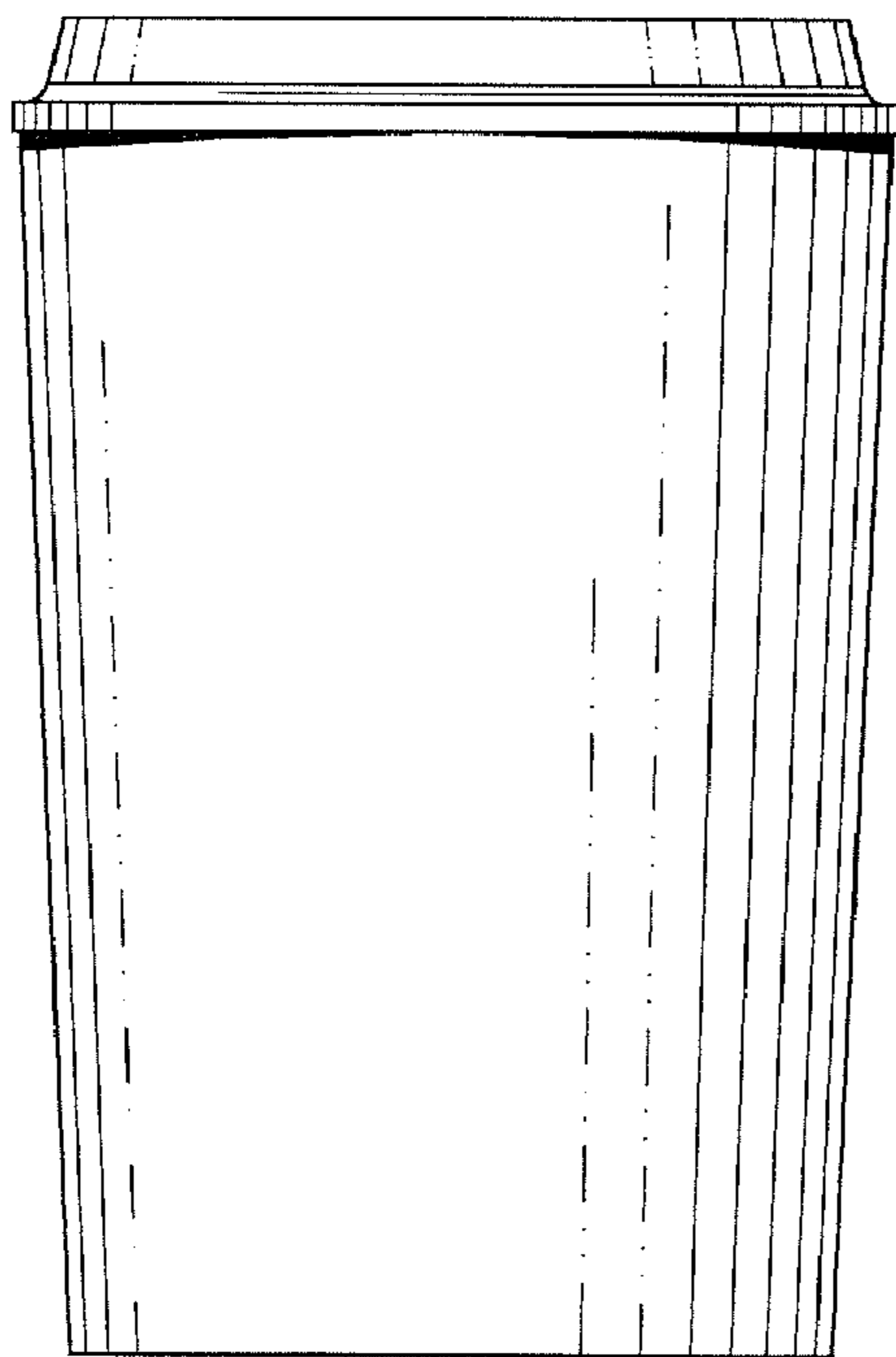

Fig. 2

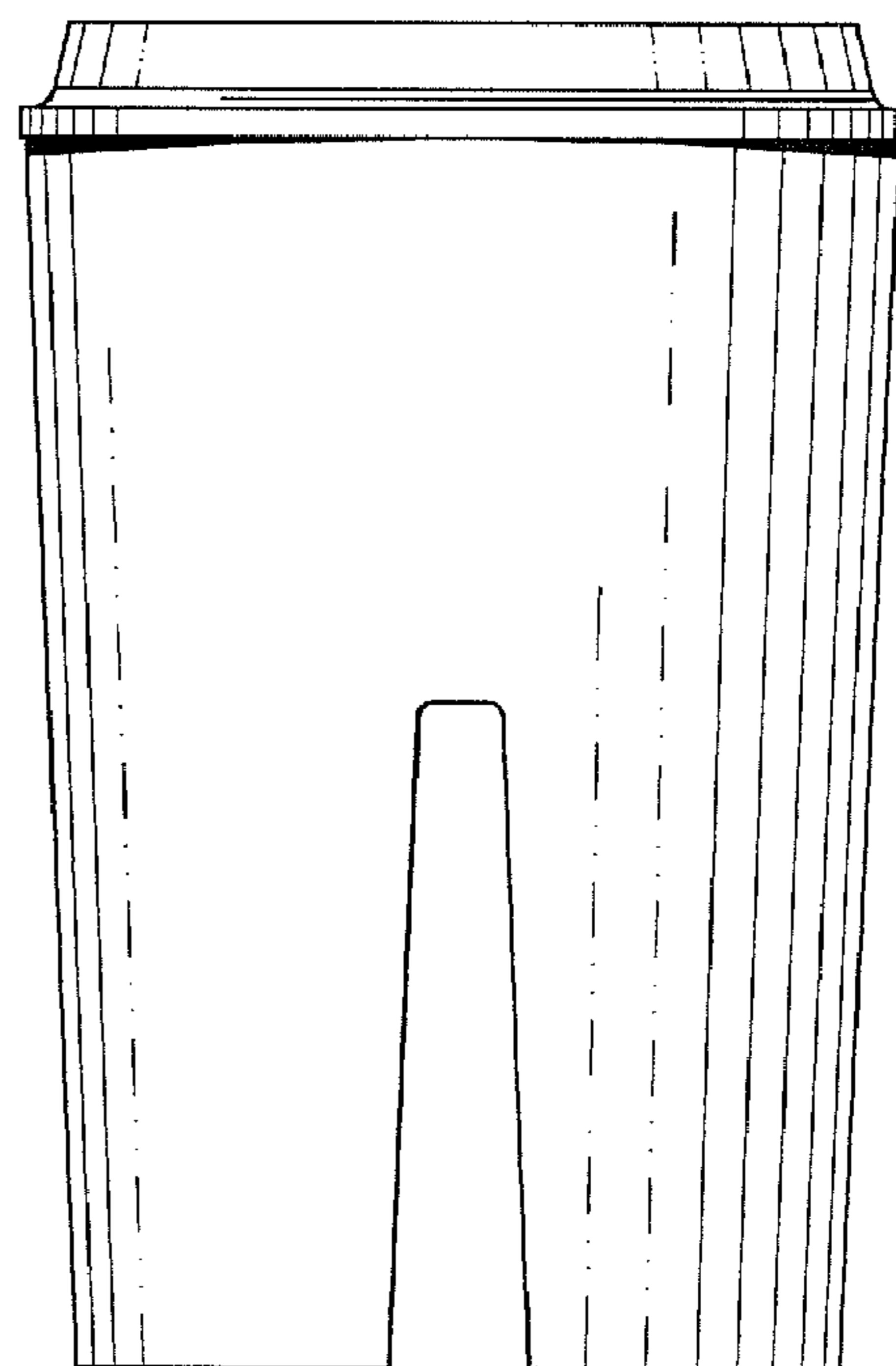

Fig. 3

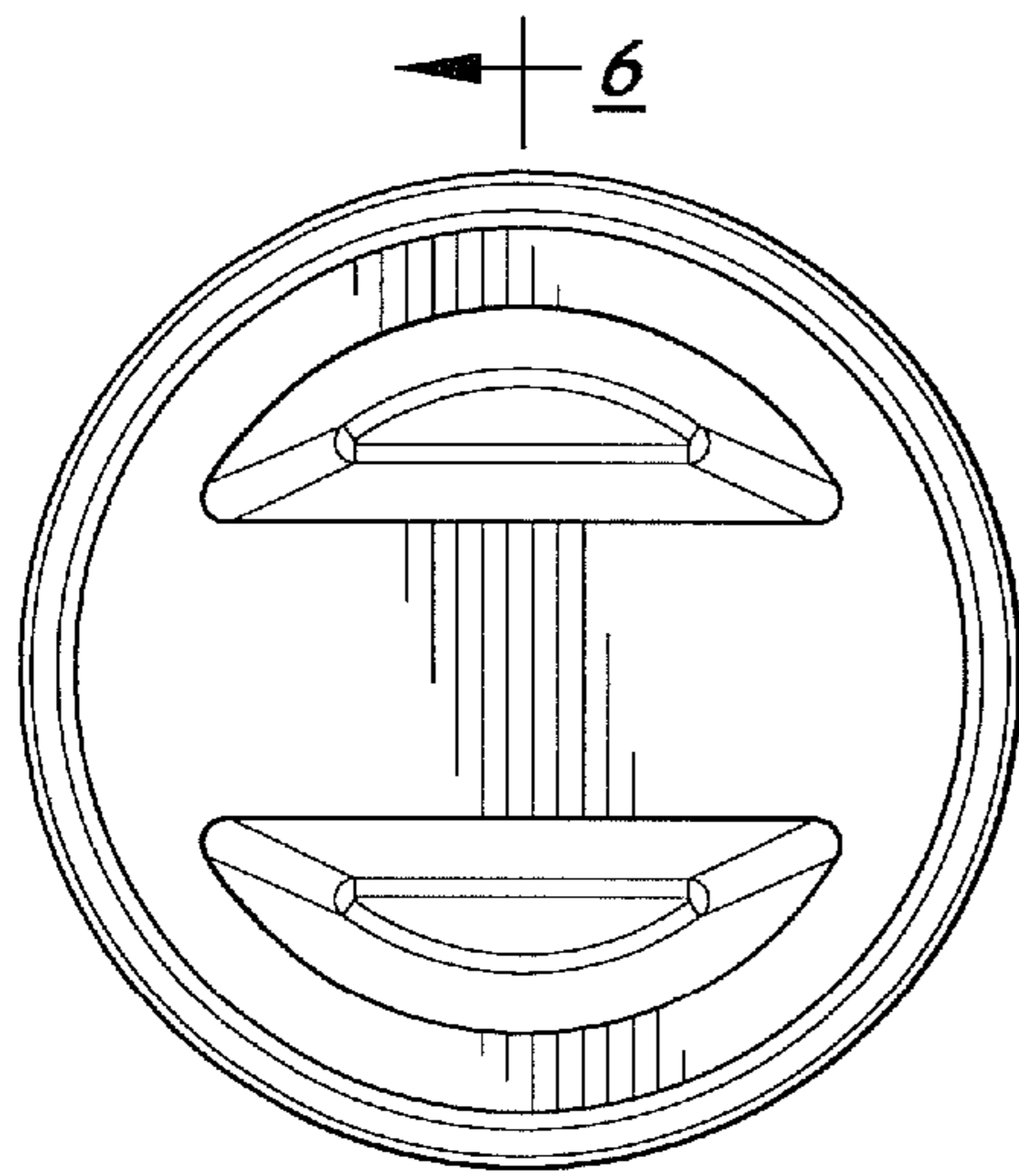

Fig. 4

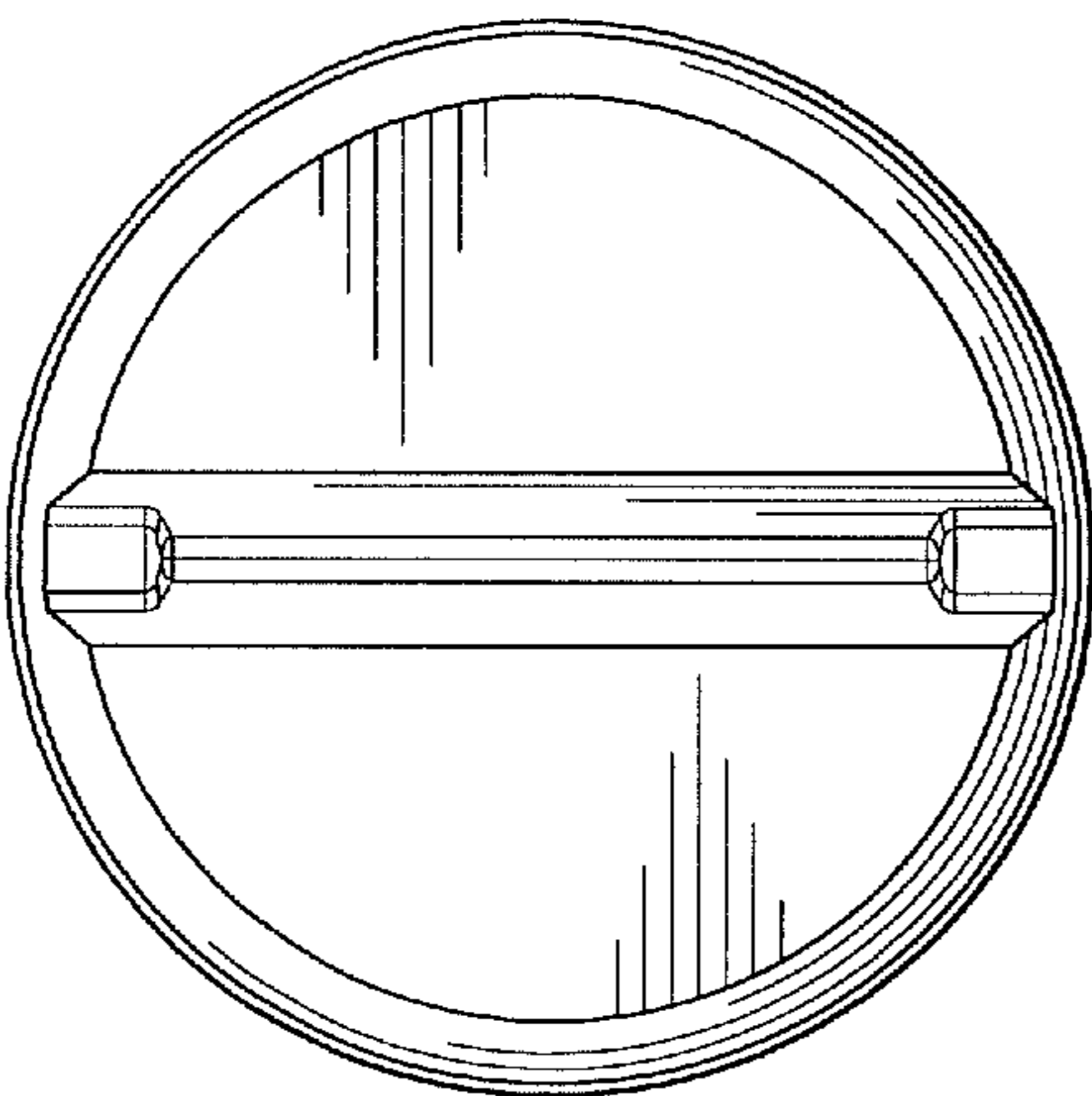

Fig. 5

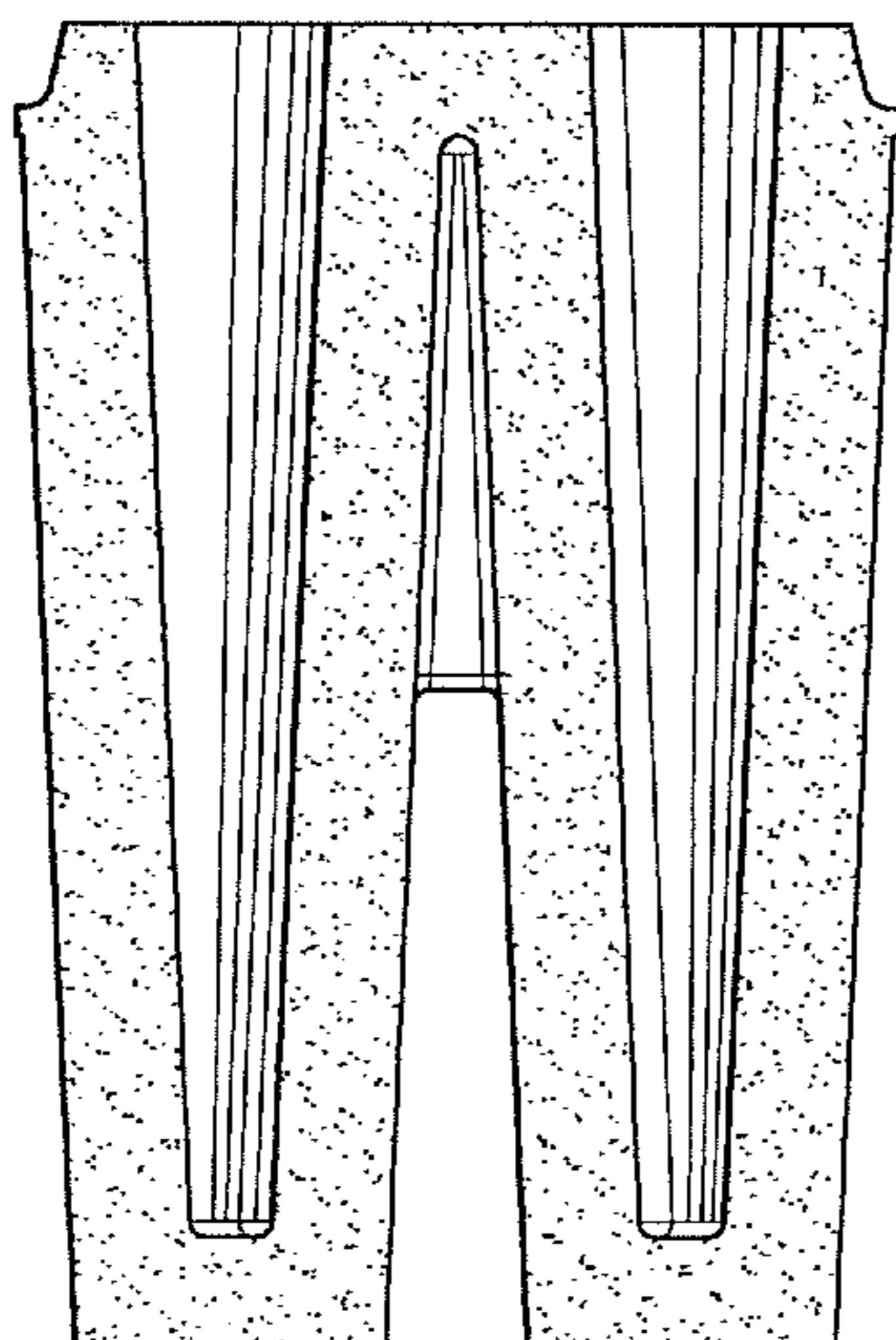

Fig. 6

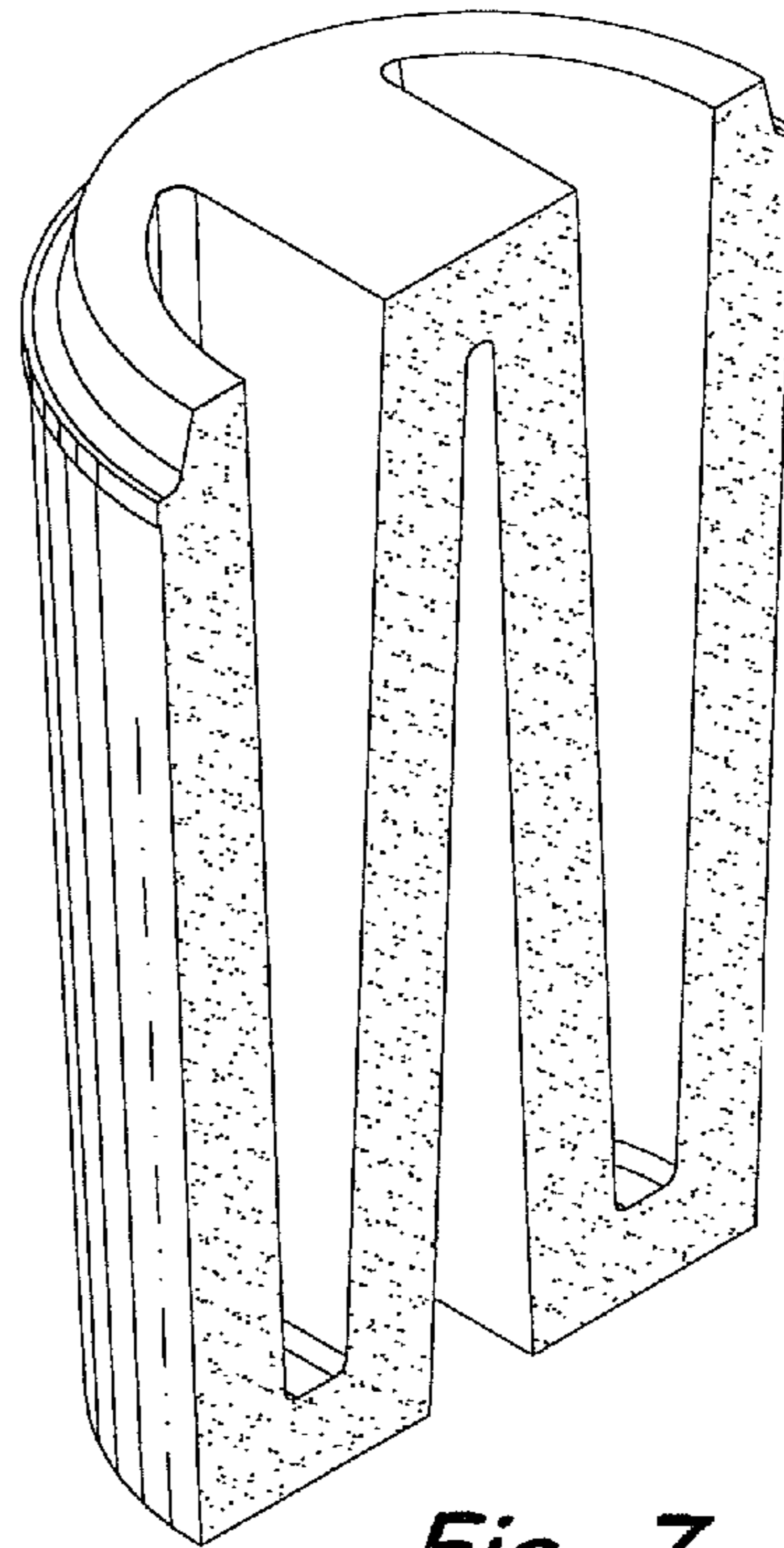

Fig. 7

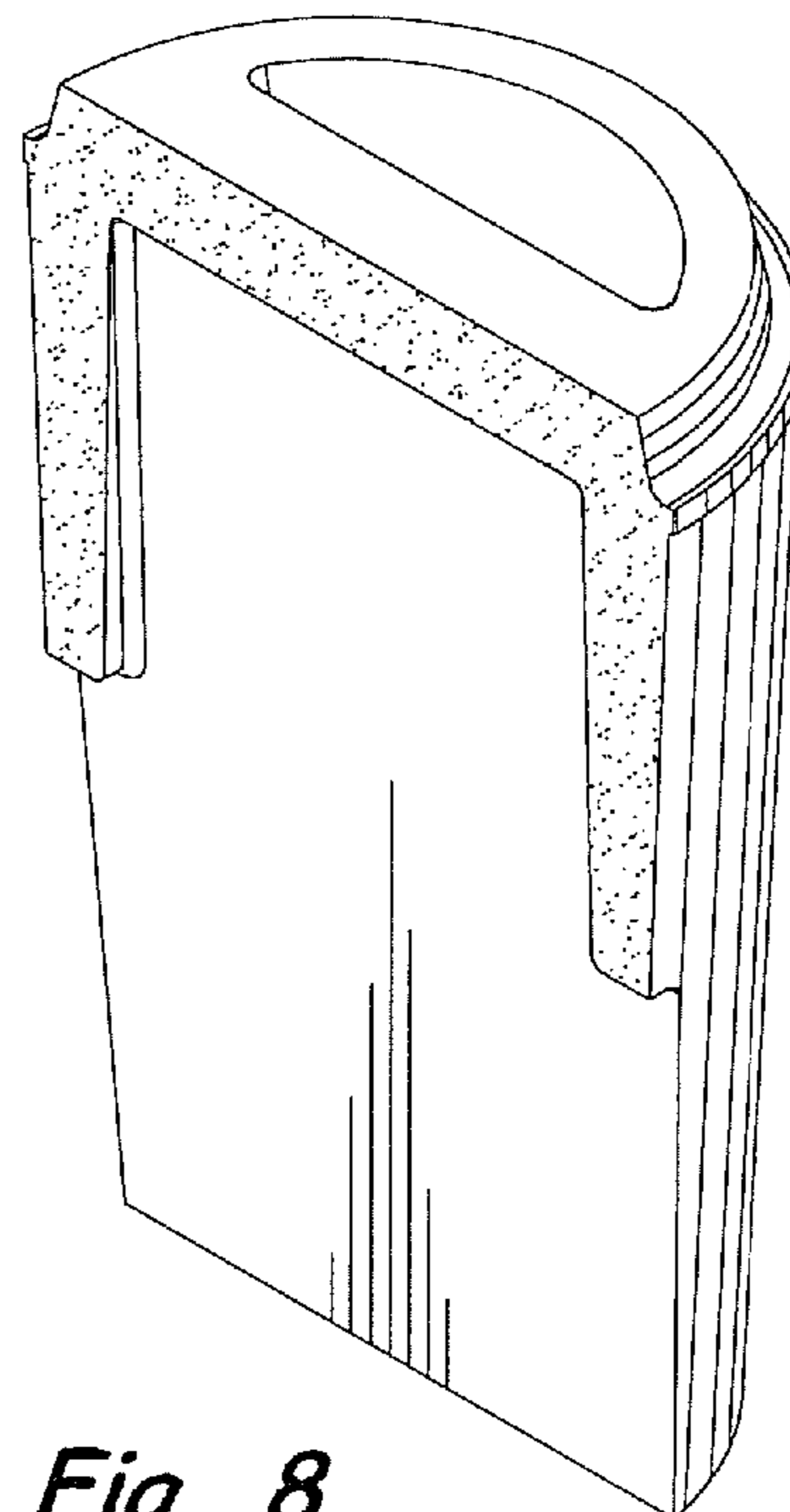

Fig. 8

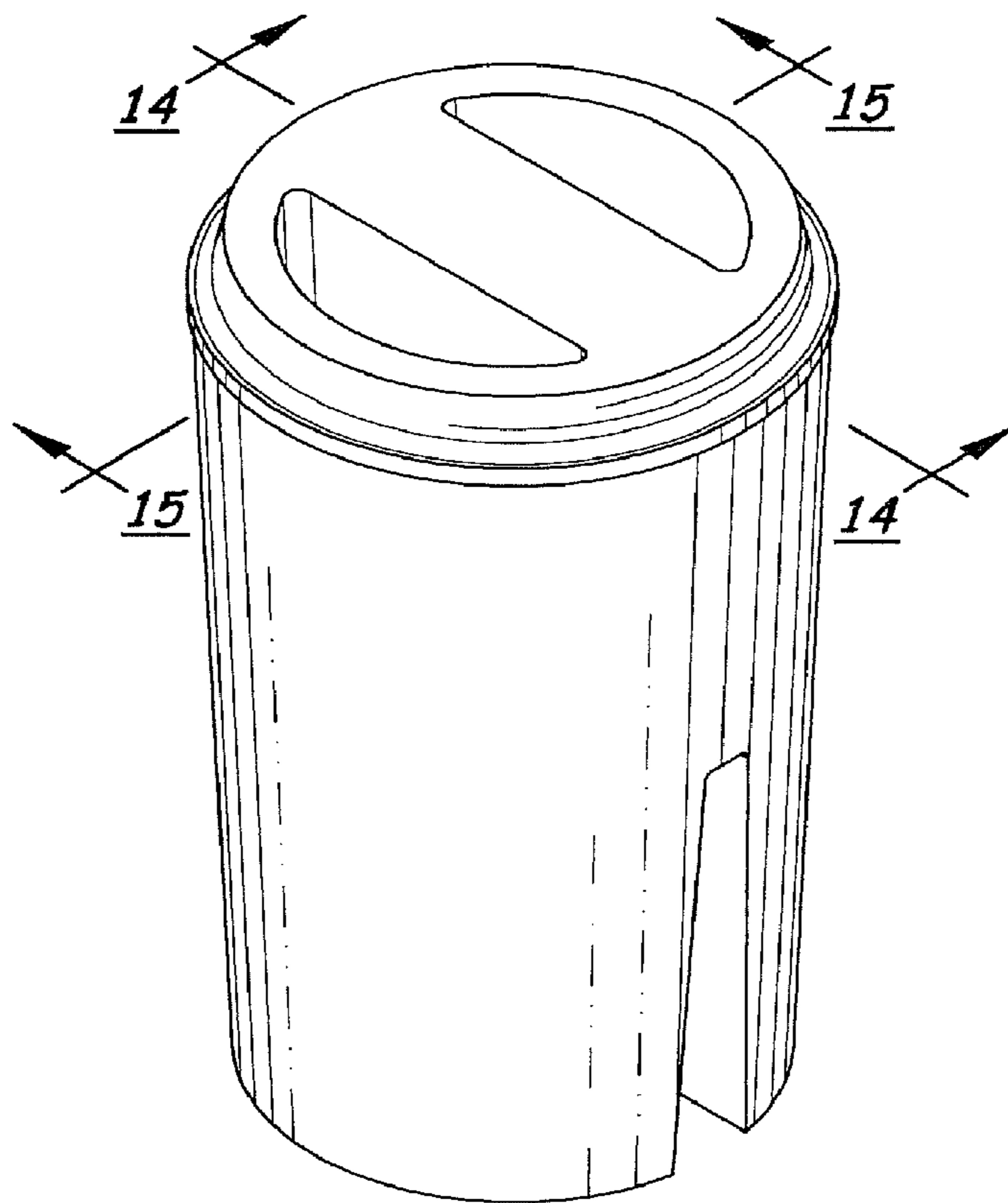

Fig. 9

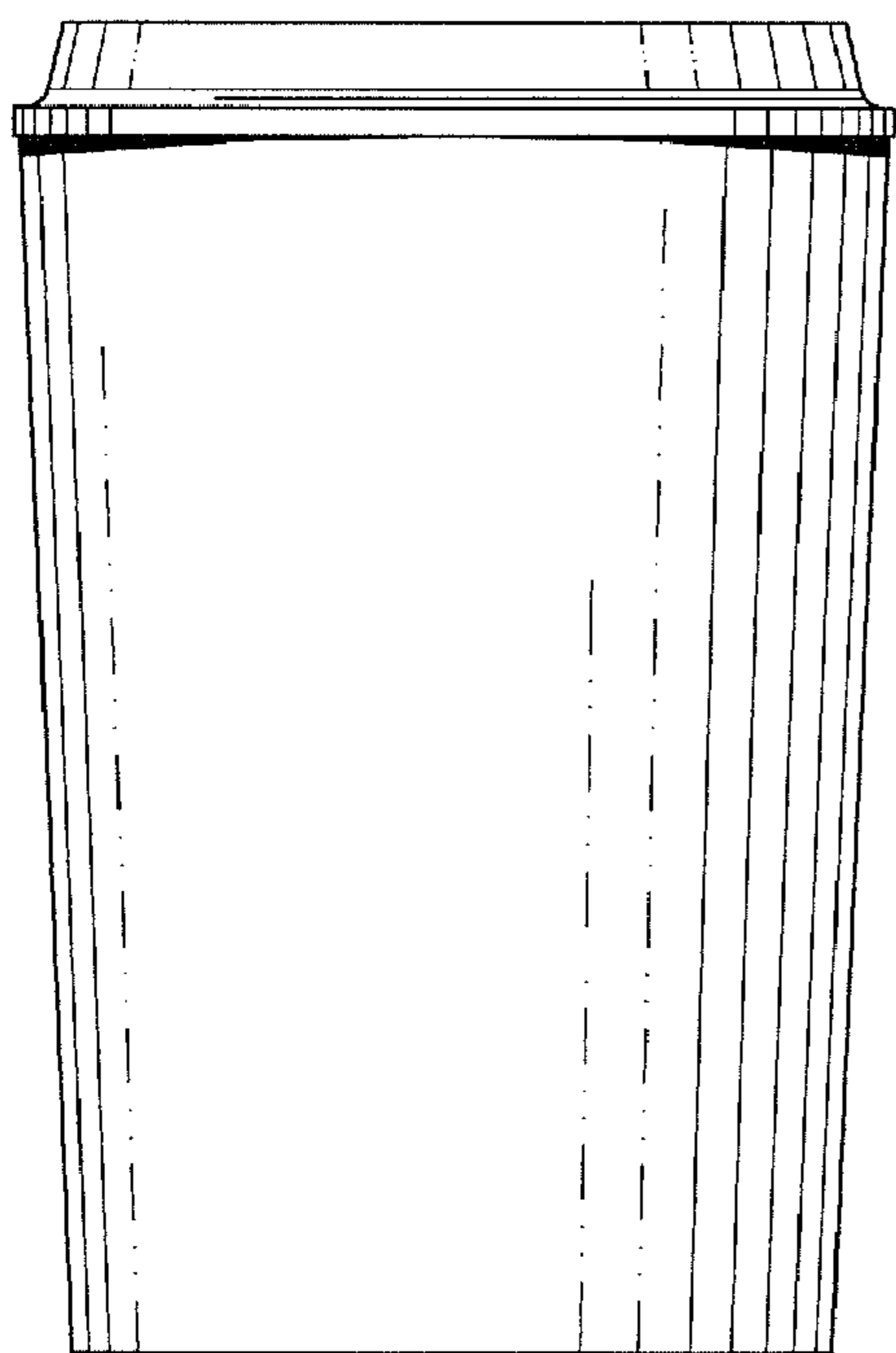

Fig. 10

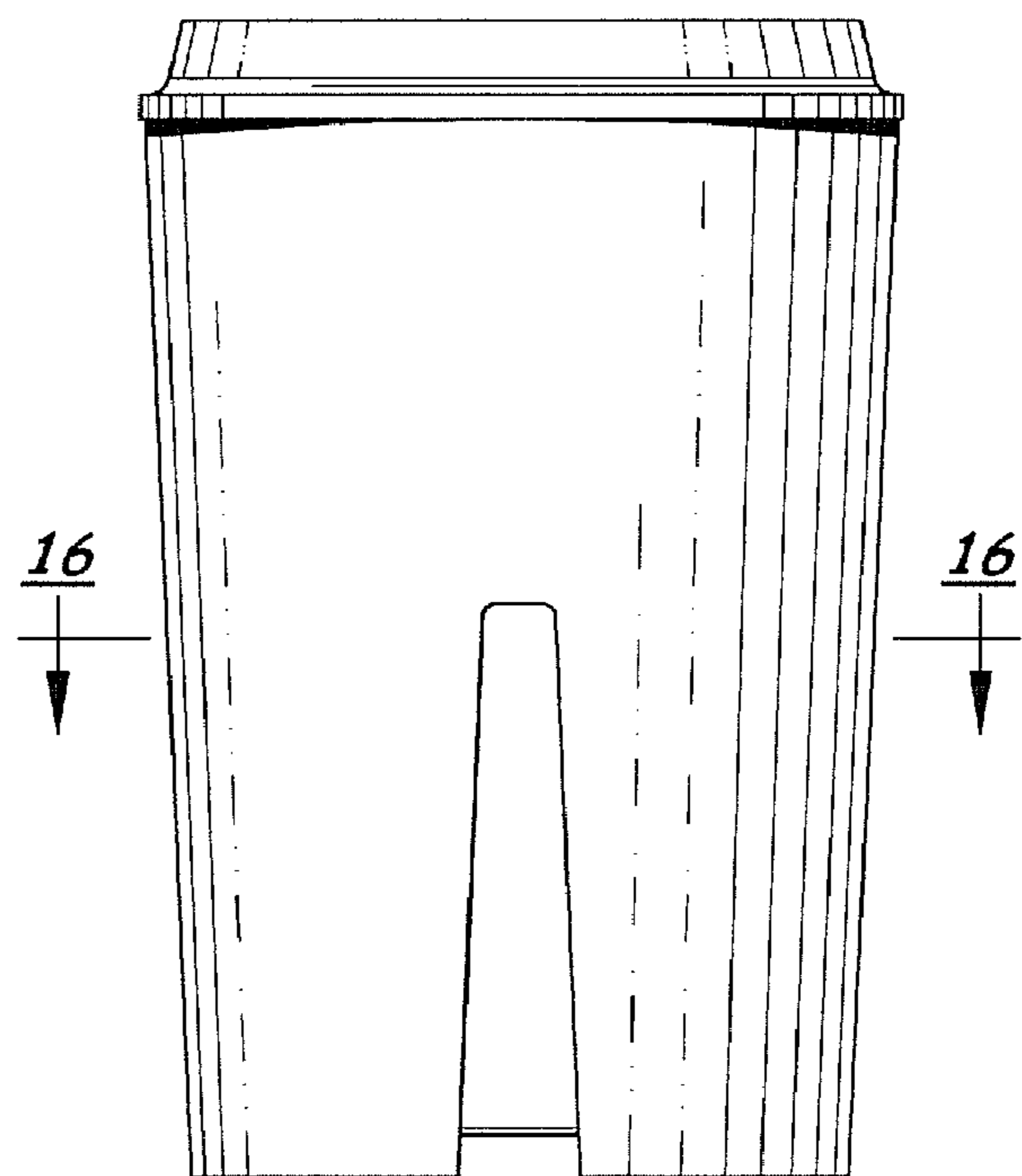

Fig. 11

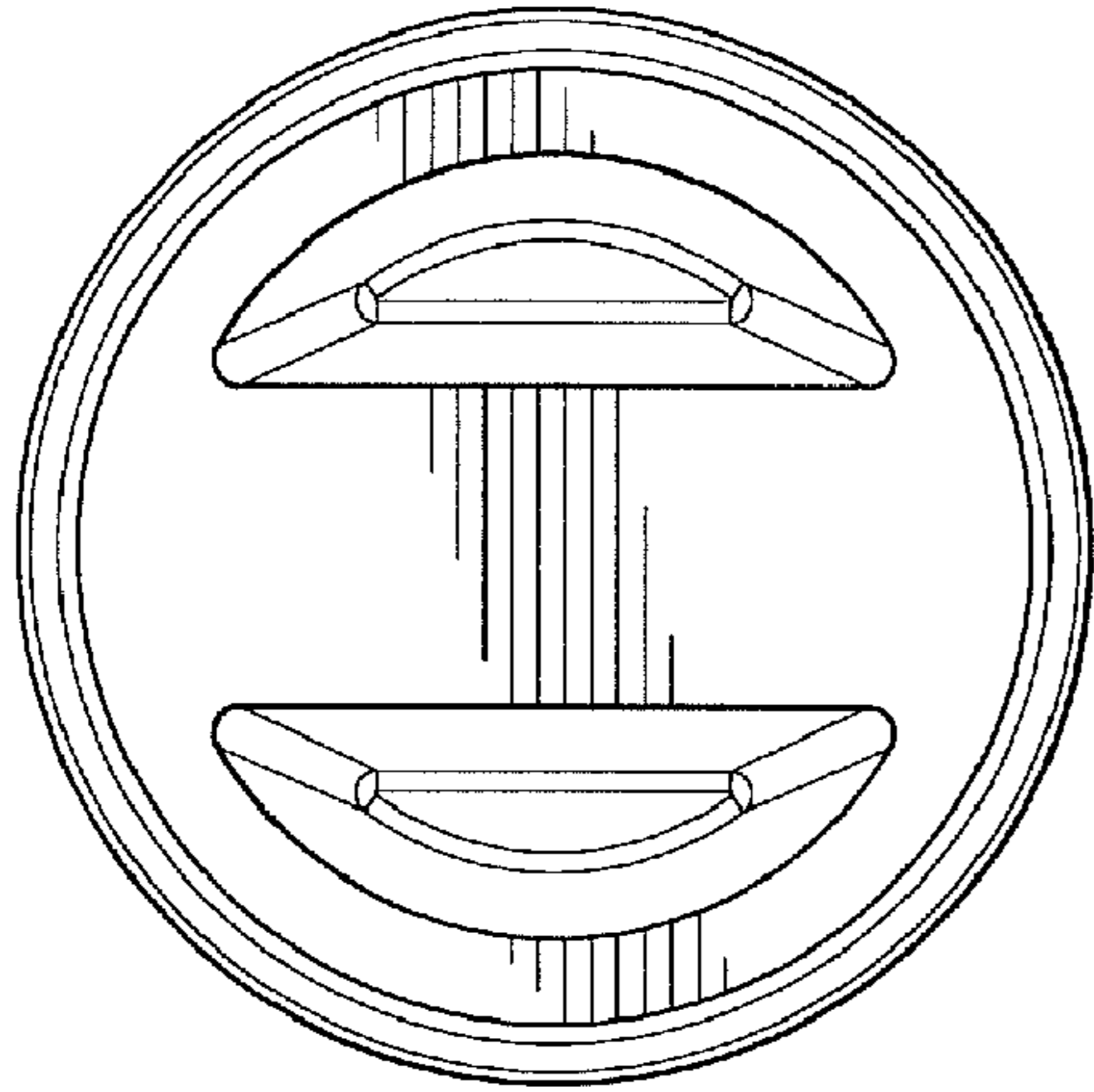

Fig. 12

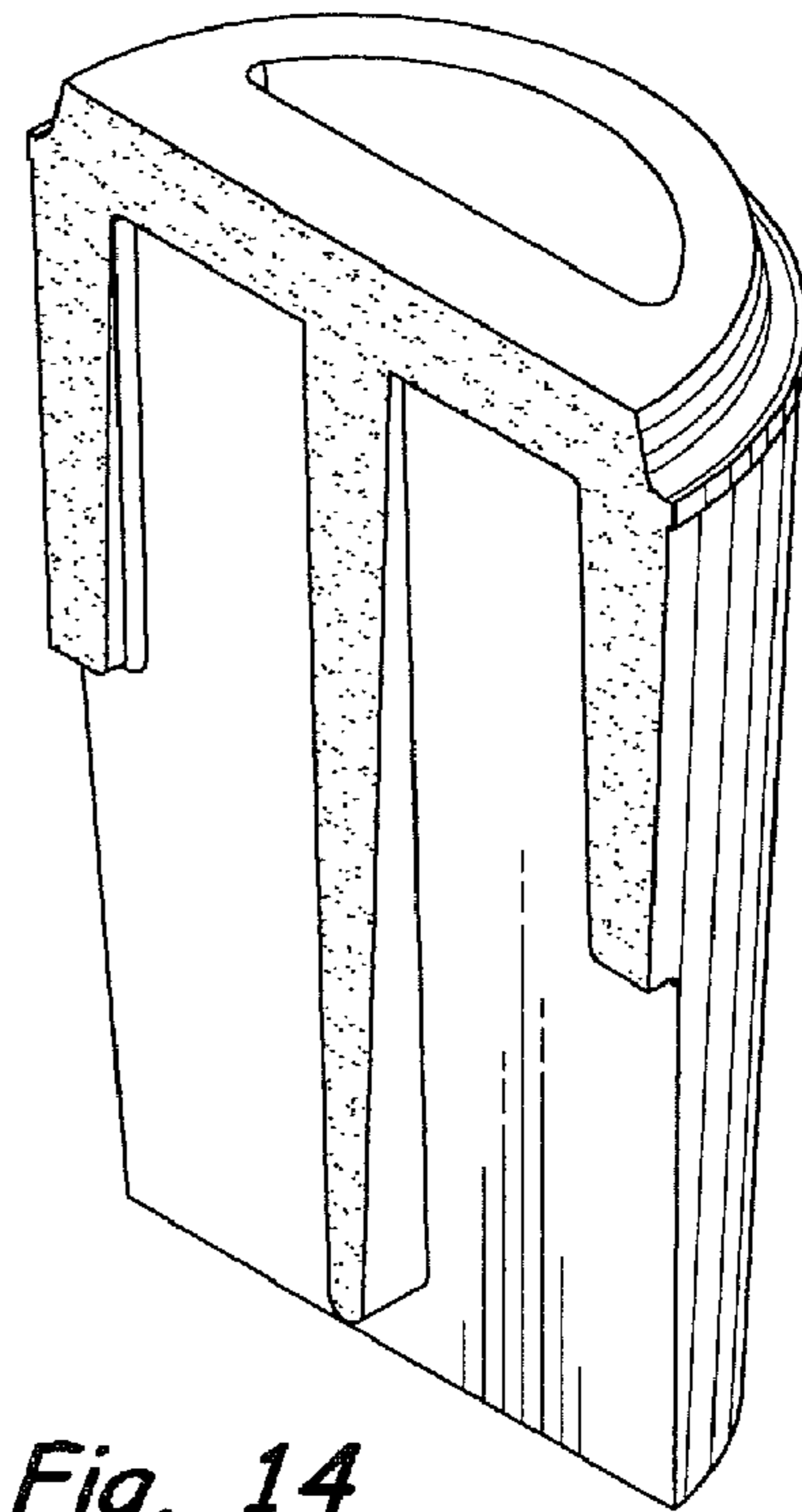

Fig. 14

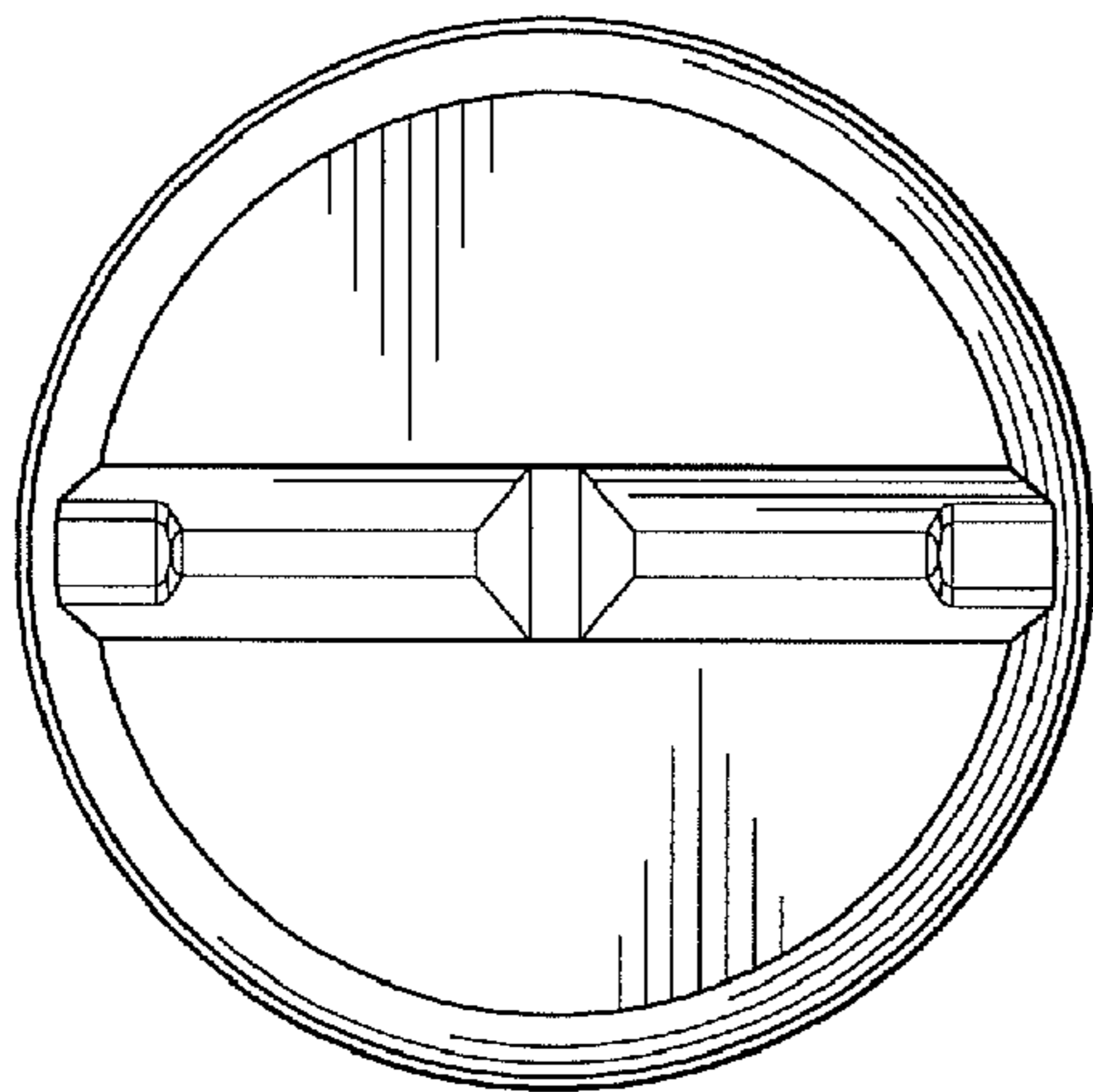

Fig. 13

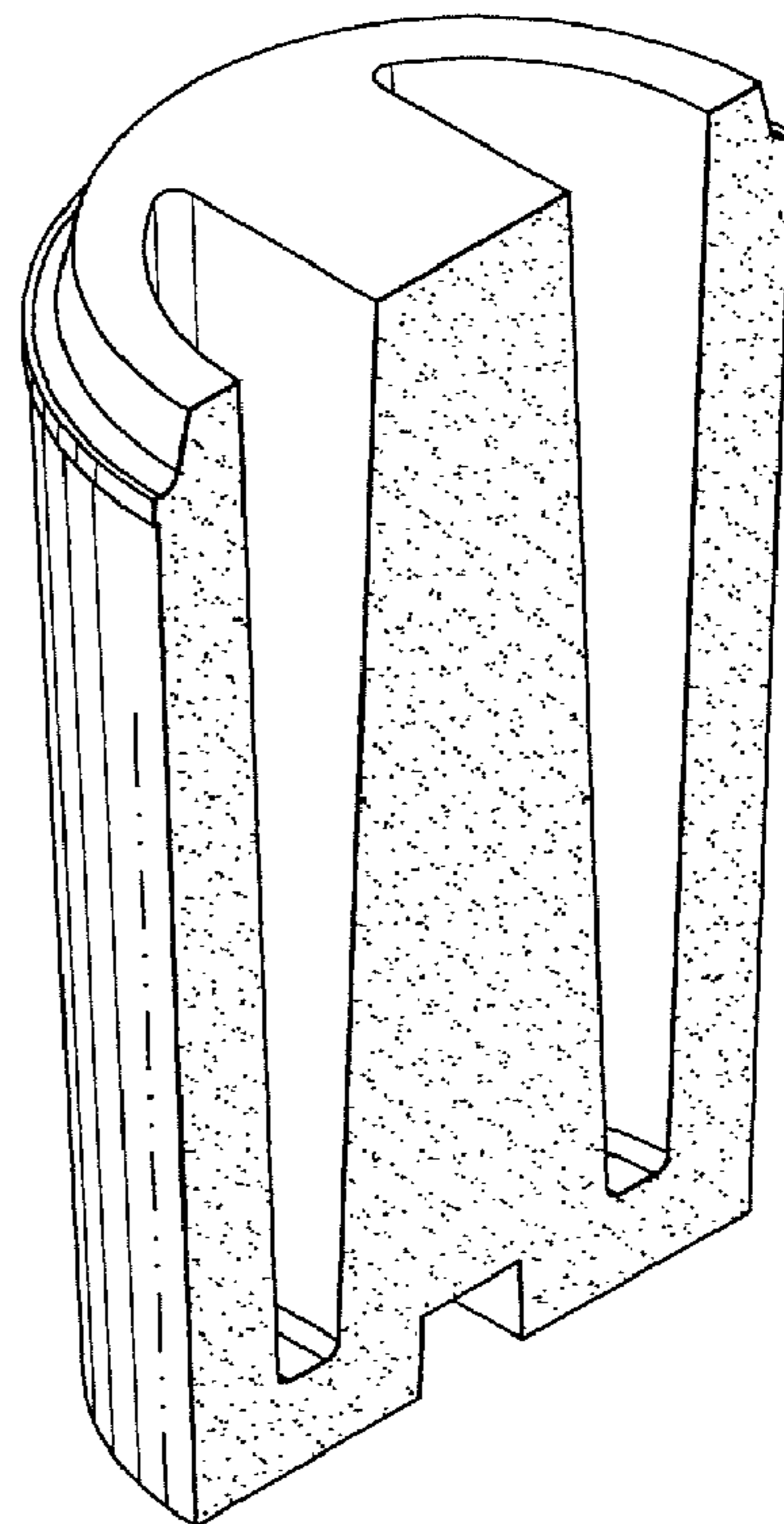

Fig. 15

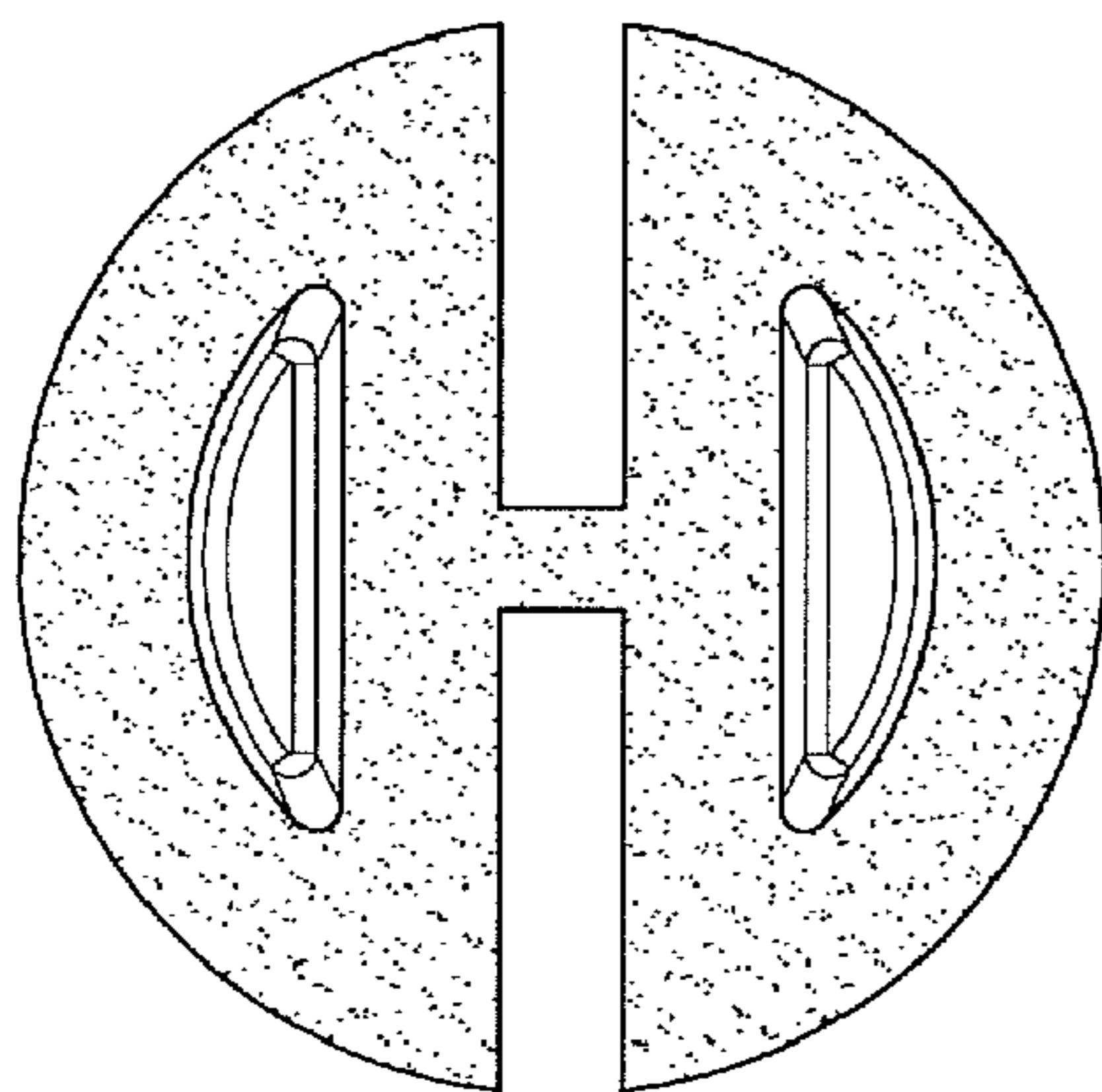

Fig. 16