



US00D615071S

(12) **United States Design Patent**  
**Hume et al.**

(10) **Patent No.:** **US D615,071 S**  
(45) **Date of Patent:** **\*\* May 4, 2010**

(54) **DEPLOYABLE SENSOR MODULE**

(75) Inventors: **Andrew Linton Hume**, Malvern (GB);  
**Dean Alastair Robert Beale**, Malvern  
(GB); **David John Green**, Malvern (GB)

(73) Assignee: **Qinetiq Limited** (GB)

(\*\*) Term: **14 Years**

(21) Appl. No.: **29/200,946**

(22) Filed: **Mar. 8, 2004**

(30) **Foreign Application Priority Data**

Sep. 9, 2003 (GB) ..... 3014334

(51) **LOC (9) Cl.** ..... **14-03**

(52) **U.S. Cl.** ..... **D14/230; D14/233; D14/238**

(58) **Field of Classification Search** ..... D14/138,  
D14/230-238, 299, 358; D12/42, 43; 343/700 R-705,  
343/871-908, 795, 840, 711-713, 819, 846;  
455/90.2, 90.3, 91, 128, 269, 344, 347, 562.1  
See application file for complete search history.

(56) **References Cited**

**U.S. PATENT DOCUMENTS**

1,756,436	A *	4/1930	Pearson	.....	343/888
3,846,797	A	11/1974	Brown et al.		
4,176,360	A *	11/1979	Leavy et al.	.....	343/883
4,598,296	A *	7/1986	Faigen et al.	.....	343/730
5,264,863	A *	11/1993	Miner et al.	.....	343/881
5,541,615	A *	7/1996	Koide et al.	.....	343/858
5,615,855	A *	4/1997	Marue et al.	.....	248/405
6,768,582	B1 *	7/2004	Hachkowski et al.	.....	359/399
7,231,741	B2 *	6/2007	Norwood	.....	52/118
2001/0004000	A1 *	6/2001	Qian et al.	.....	156/184

2003/0107488	A1	6/2003	Van Putten		
2004/0046022	A1 *	3/2004	Hassan-Zade et al.	.....	235/435
2007/0146227	A1 *	6/2007	Brooks et al.	.....	343/881

**FOREIGN PATENT DOCUMENTS**

DE 100 13 084 9/2001

\* cited by examiner

*Primary Examiner*—T. Chase Nelson  
*Assistant Examiner*—John Windmuller

(74) *Attorney, Agent, or Firm*—McDonnell Boehnen  
Hulbert & Berghoff LLP

(57) **CLAIM**

The ornamental design for a deployable sensor module, as shown and described.

**DESCRIPTION**

FIG. 1 is a perspective view from above and one side of an embodiment of a deployable sensor module in a stowed configuration;

FIG. 2 is a front elevation view of an embodiment of a deployable sensor module in a stowed configuration;

FIG. 3 is a top view of an embodiment of a deployable sensor module in a stowed configuration;

FIG. 4 is a front perspective view from above of an embodiment of a deployable sensor module in a partially deployed configuration; and,

FIG. 5 is a front perspective view of an embodiment of a deployable sensor module in a fully deployed.

In FIGS. 1, 3, 4, and 5, the broken lines depict portions of the module that form no part of the claimed design.

**1 Claim, 5 Drawing Sheets**

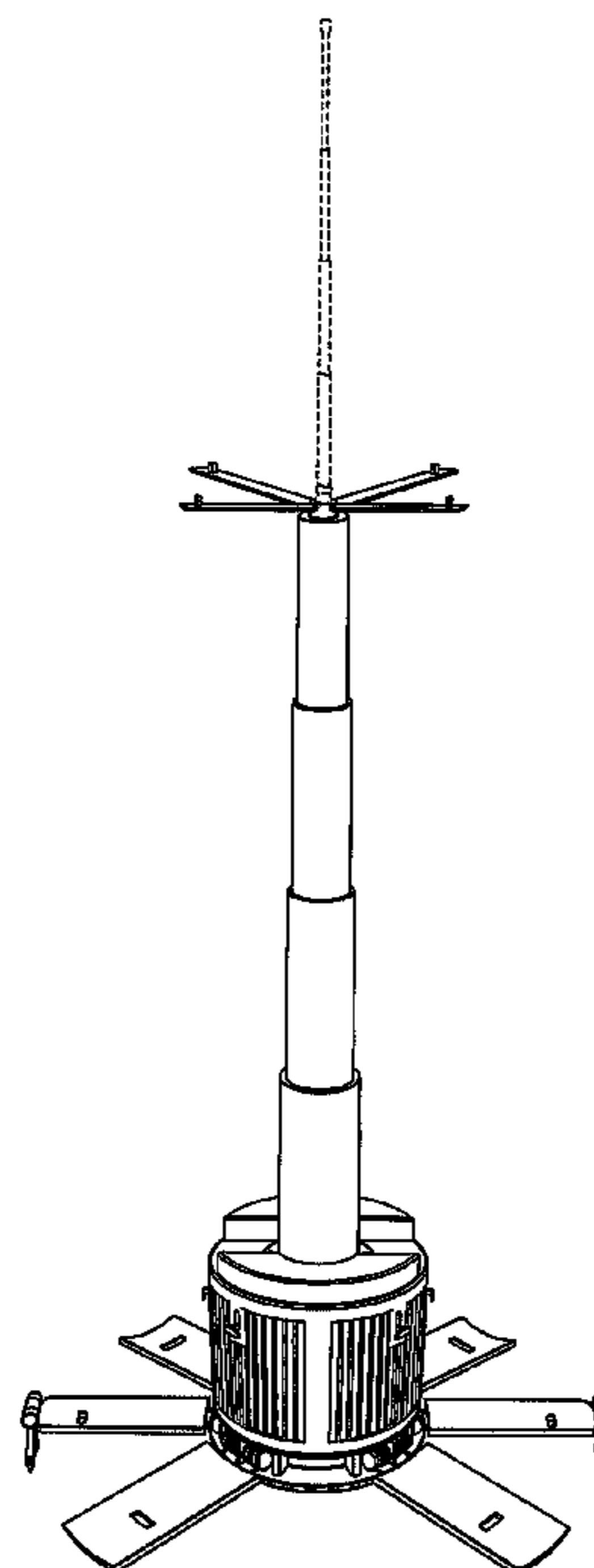
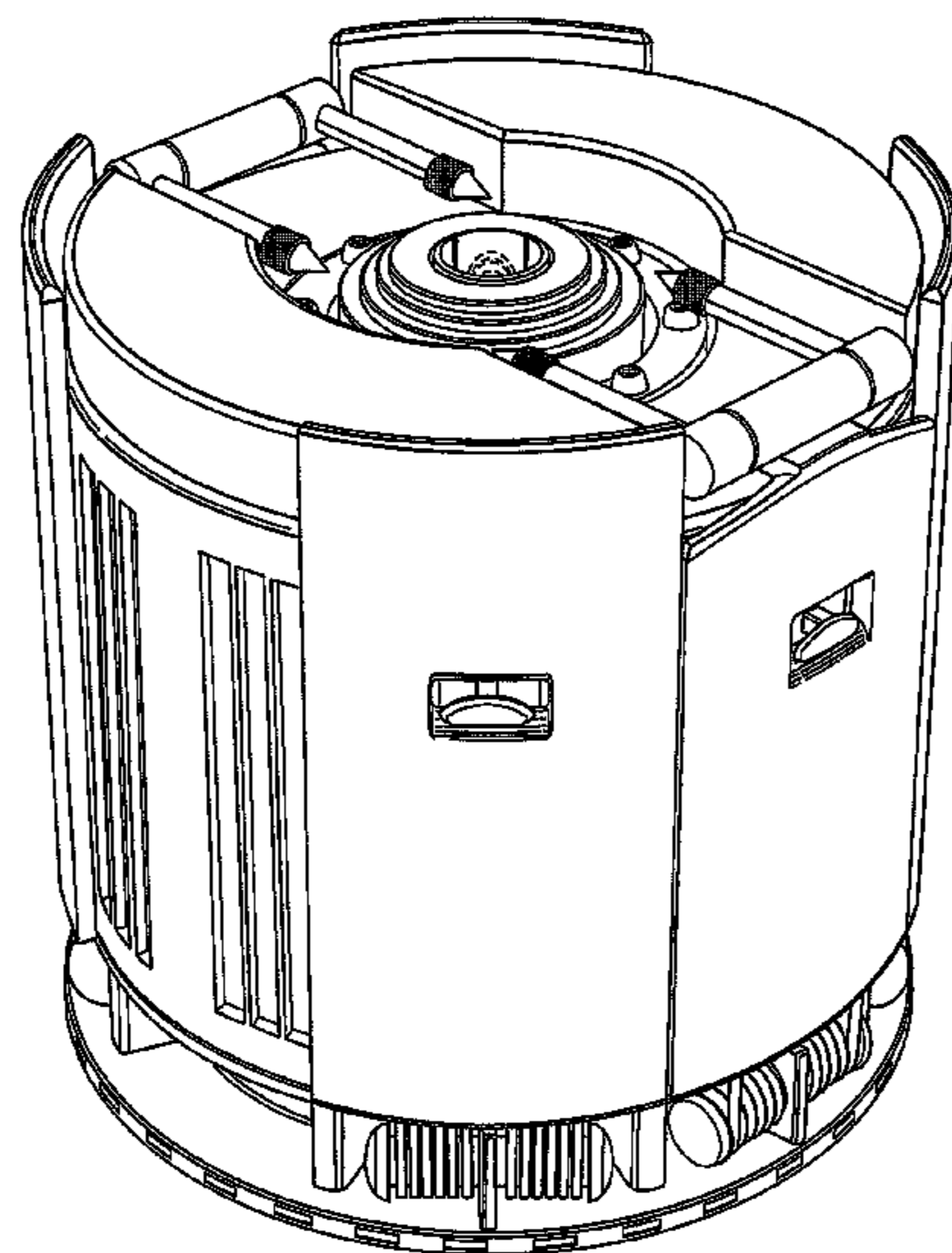

Fig. 1

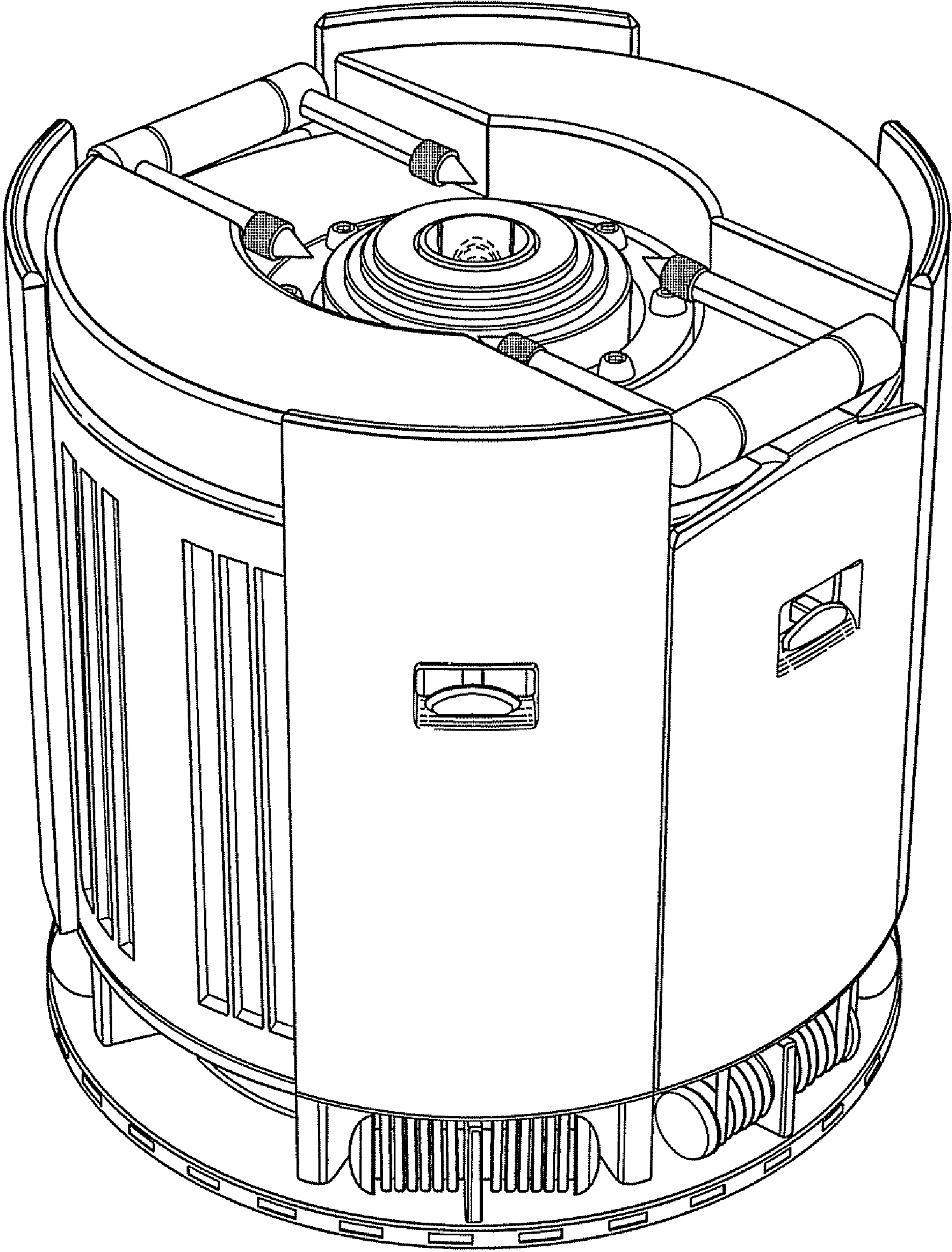

Fig. 2

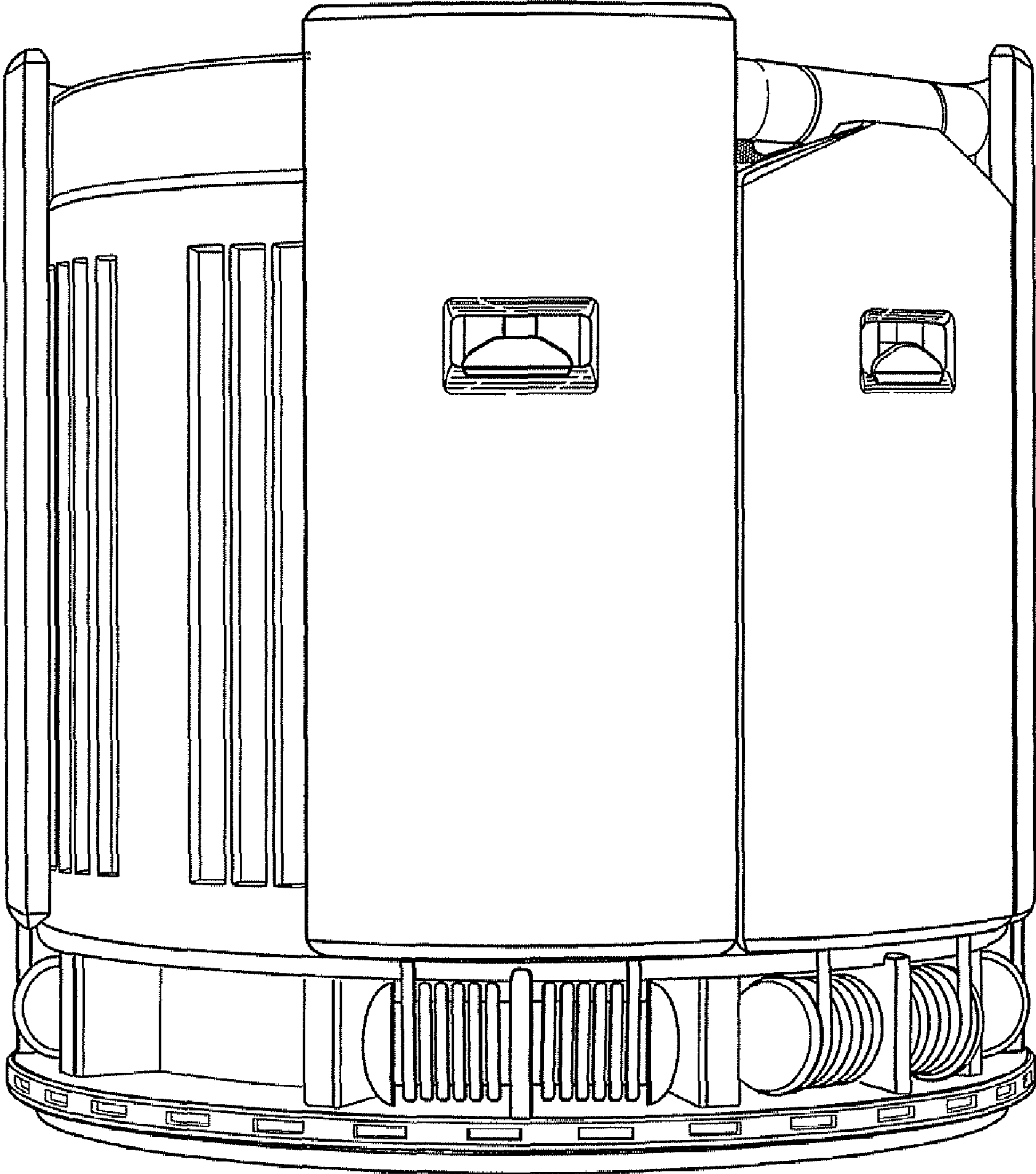



Fig. 3

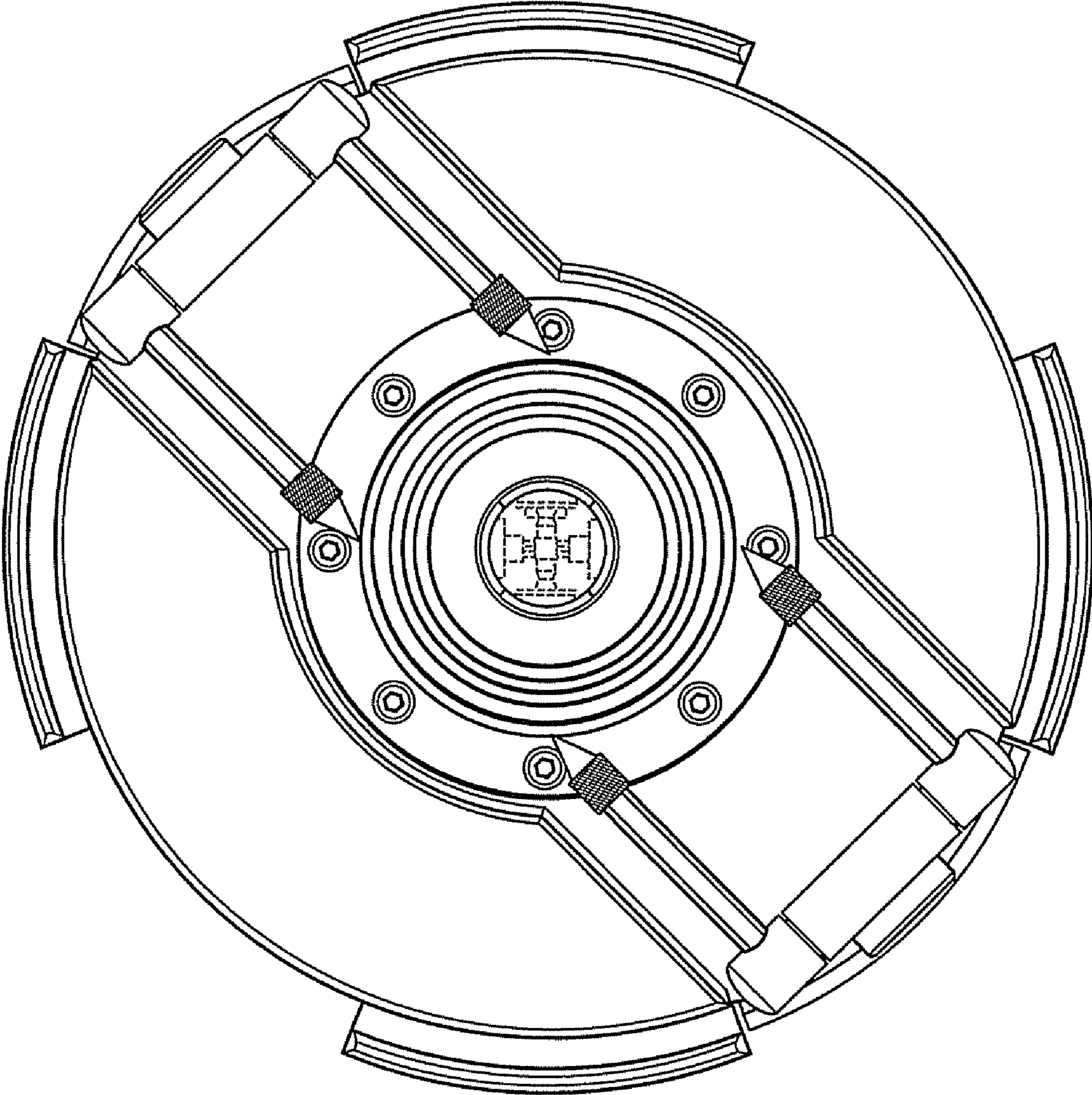

Fig. 4

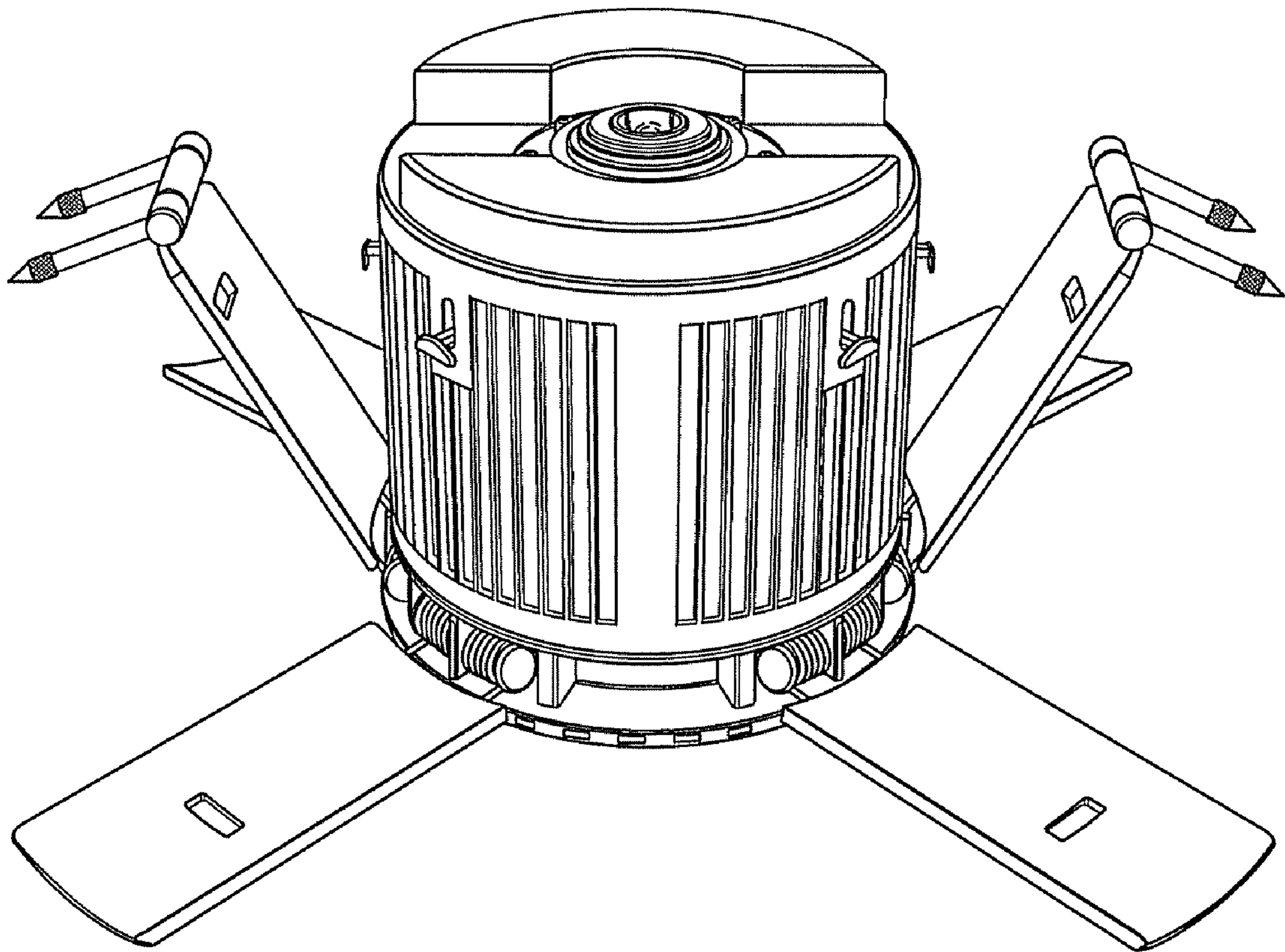

Fig. 5

