



US00D615045S

(12) **United States Design Patent**
Lanfear et al.

(10) **Patent No.:** **US D615,045 S**
(45) **Date of Patent:** **** May 4, 2010**

- (54) **ATTENDANT MODULE**
- (75) Inventors: **Tina M. Lanfear**, Hansville, WA (US);
Harold Erickson, Mukilteo, WA (US);
Hoi Truong, Bothell, WA (US)
- (73) Assignee: **The Boeing Company**, Chicago, IL
(US)
- (**) Term: **14 Years**
- (21) Appl. No.: **29/344,757**
- (22) Filed: **Oct. 2, 2009**

- D586,740 S 2/2009 Song
- D586,742 S 2/2009 Song
- D592,131 S * 5/2009 Heinzen et al. D13/103
- D592,595 S 5/2009 Heinzen
- D604,254 S * 11/2009 Lanfear et al. D13/162
- 7,613,546 B2 * 11/2009 Nelson et al. 700/284
- 2008/0058964 A1 3/2008 Nickerson

OTHER PUBLICATIONS

Photograph of ILF/SKM 767-300 aircraft, Aug. 1998.
Photograph of KLM-777 aircraft, Oct. 2003.

* cited by examiner

Primary Examiner—Daniel D Bui
Assistant Examiner—Thomas J Johannes
(74) *Attorney, Agent, or Firm*—Ostrager Chong Flaherty & Broitman P.C.

Related U.S. Application Data

- (62) Division of application No. 29/305,757, filed on Mar. 27, 2008, now Pat. No. Des. 604,254.

- (51) **LOC (9) Cl.** **13-03**
- (52) **U.S. Cl.** **D13/162; D13/184**
- (58) **Field of Classification Search** D13/103,
D13/119, 162, 164, 184, 199; D14/240,
D14/496; 174/17 R, 50, 51, 52, 52.1, 58;
312/100, 263, 292, 293.1–293.3, 294; 220/3.3,
220/3.8, 3.92; 361/600, 601, 622, 679, 686,
361/720, 724, 728, 748, 752, 796; 379/419,
379/428.01, 440, 441, 442

See application file for complete search history.

(57) **CLAIM**

The ornamental design for an attendant module, as shown and described.

DESCRIPTION

FIG. 1 is a front, top and right side perspective view of a first embodiment of an attendant module showing our new design;
 FIG. 2 is a front view thereof;
 FIG. 3 is a top view thereof;
 FIG. 4 is a right side view thereof;
 FIG. 5 is a left side view thereof;
 FIG. 6 is a bottom view thereof;
 FIG. 7 is a front, top and right side perspective view of a second embodiment of an attendant module showing our new design;
 FIG. 8 is a front view thereof;
 FIG. 9 is a top view thereof;
 FIG. 10 is a right side view thereof;
 FIG. 11 is a left side view thereof; and,
 FIG. 12 is a bottom view thereof.

(56) **References Cited**

U.S. PATENT DOCUMENTS

- D284,959 S 8/1986 Berg
- D380,199 S 6/1997 Beruscha
- 5,754,643 A * 5/1998 Decker et al. 379/413.02
- D400,512 S 11/1998 Korhonen
- D403,656 S * 1/1999 Ichikawa D13/103
- 5,907,127 A * 5/1999 Daoud 174/57
- D417,188 S * 11/1999 Maeyama D13/103
- D425,493 S 5/2000 Cutright
- D438,532 S 3/2001 Gargani
- D489,337 S 5/2004 Murray
- D517,507 S 3/2006 Johnson
- D518,451 S 4/2006 Nussberger
- D533,092 S 12/2006 Disselkoen
- D542,230 S 5/2007 Merritt
- D567,776 S 4/2008 Wells
- D580,373 S 11/2008 Stange

1 Claim, 8 Drawing Sheets

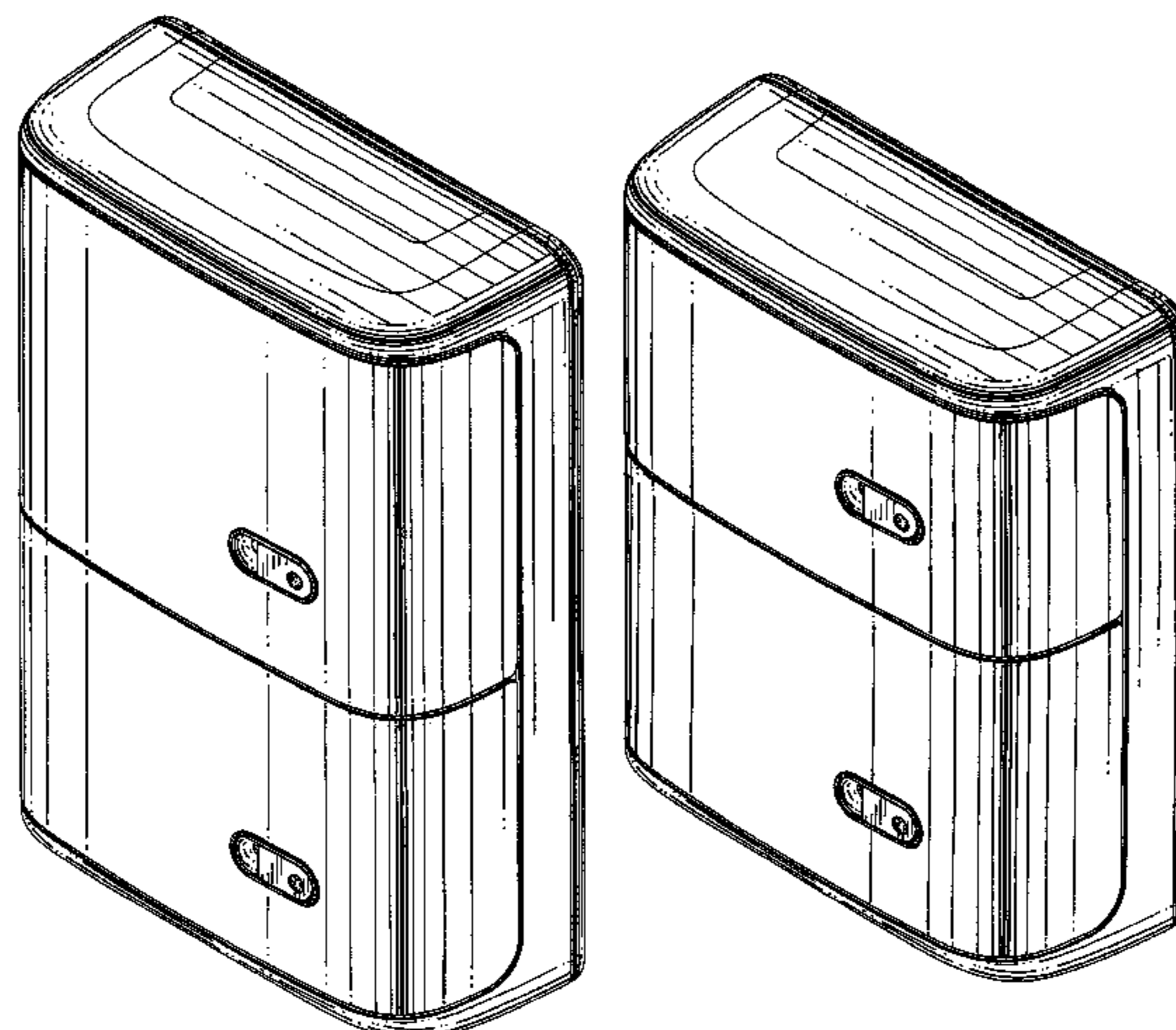

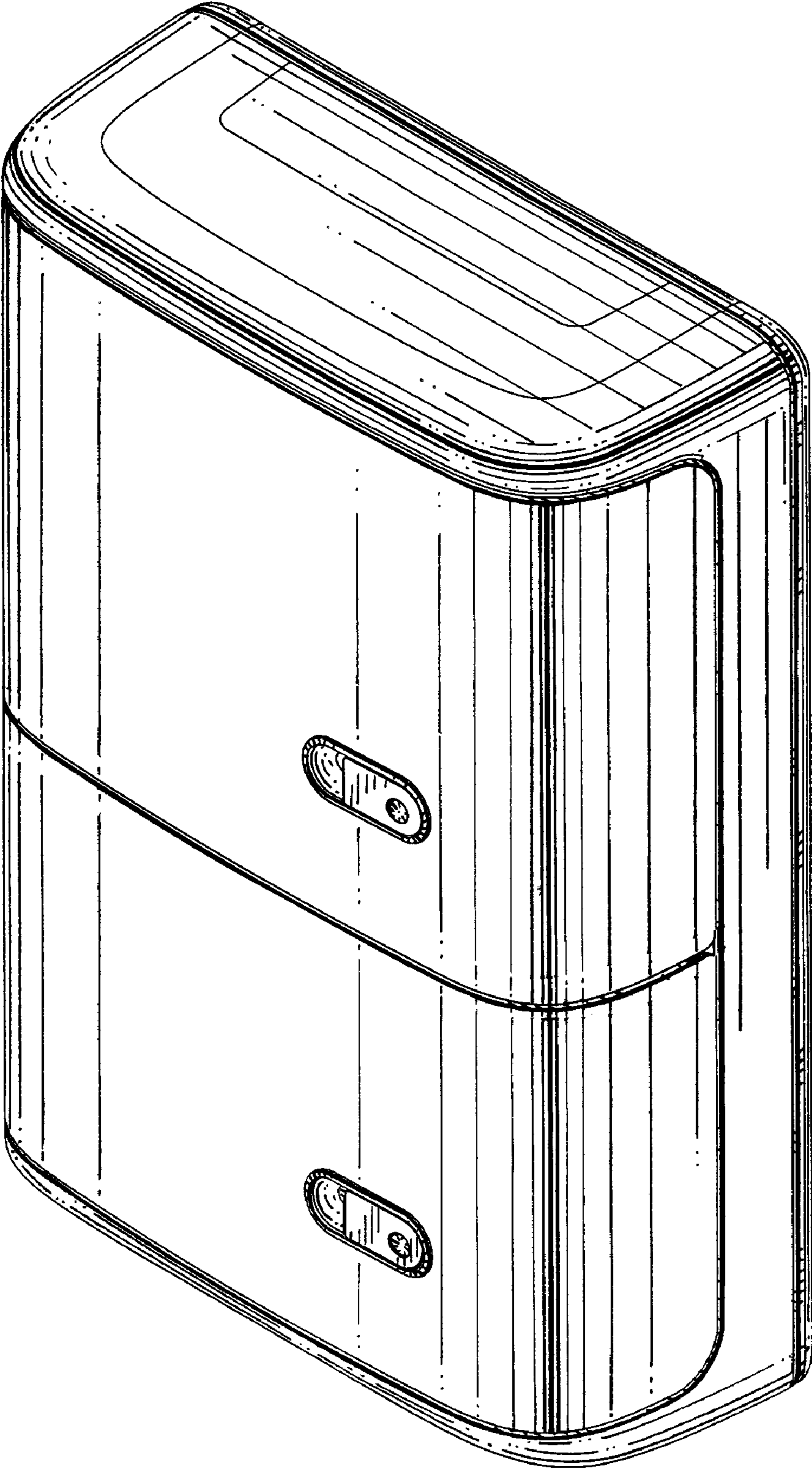

FIG. 1

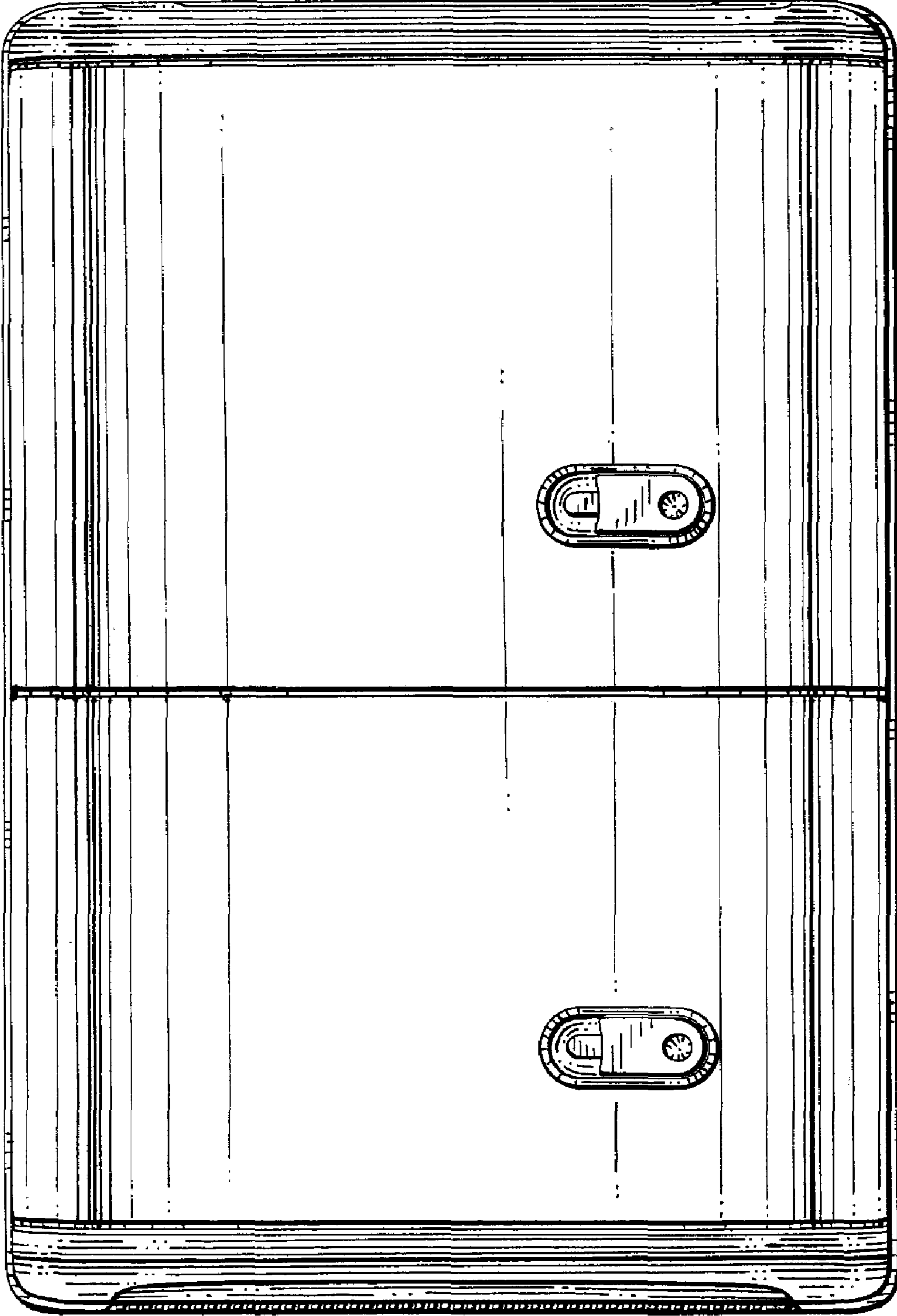

FIG.2

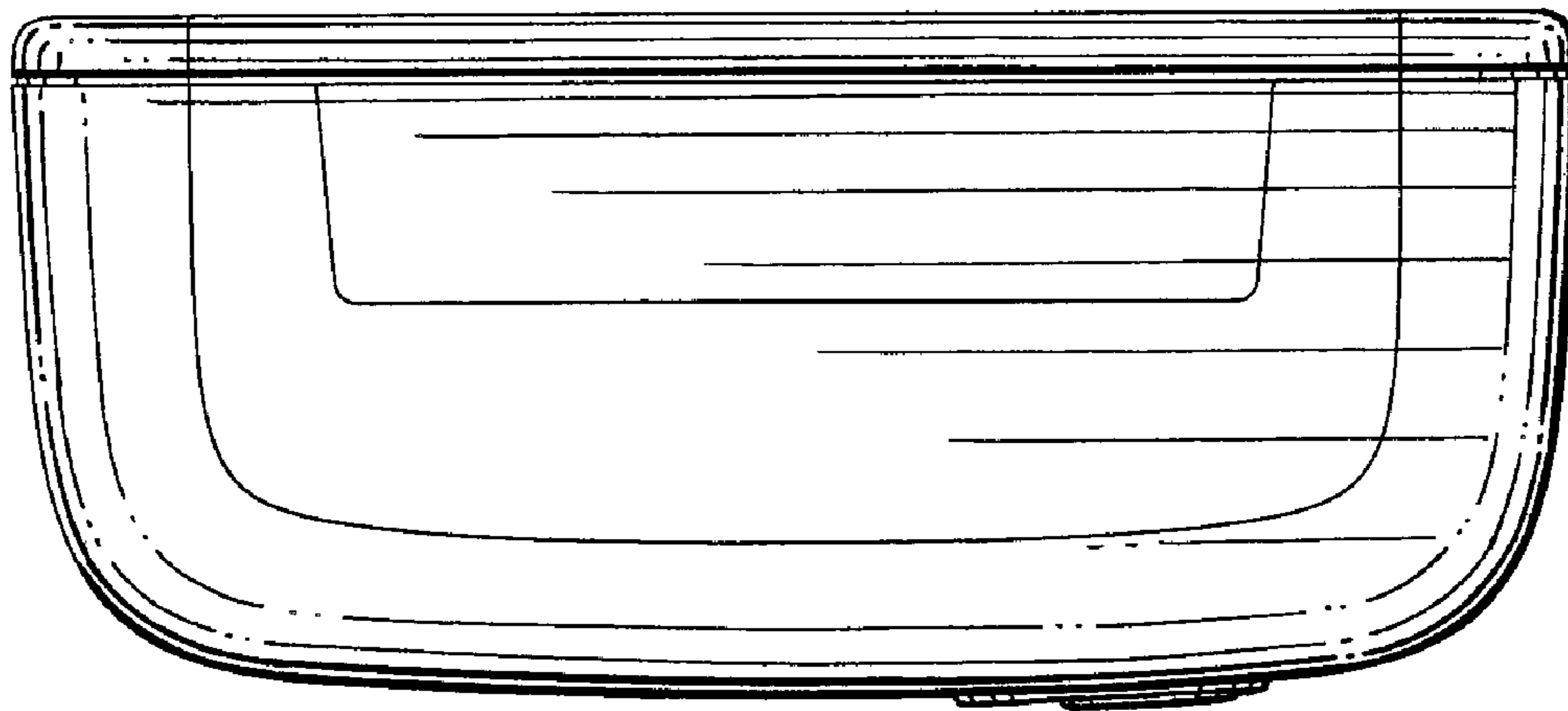

FIG. 3

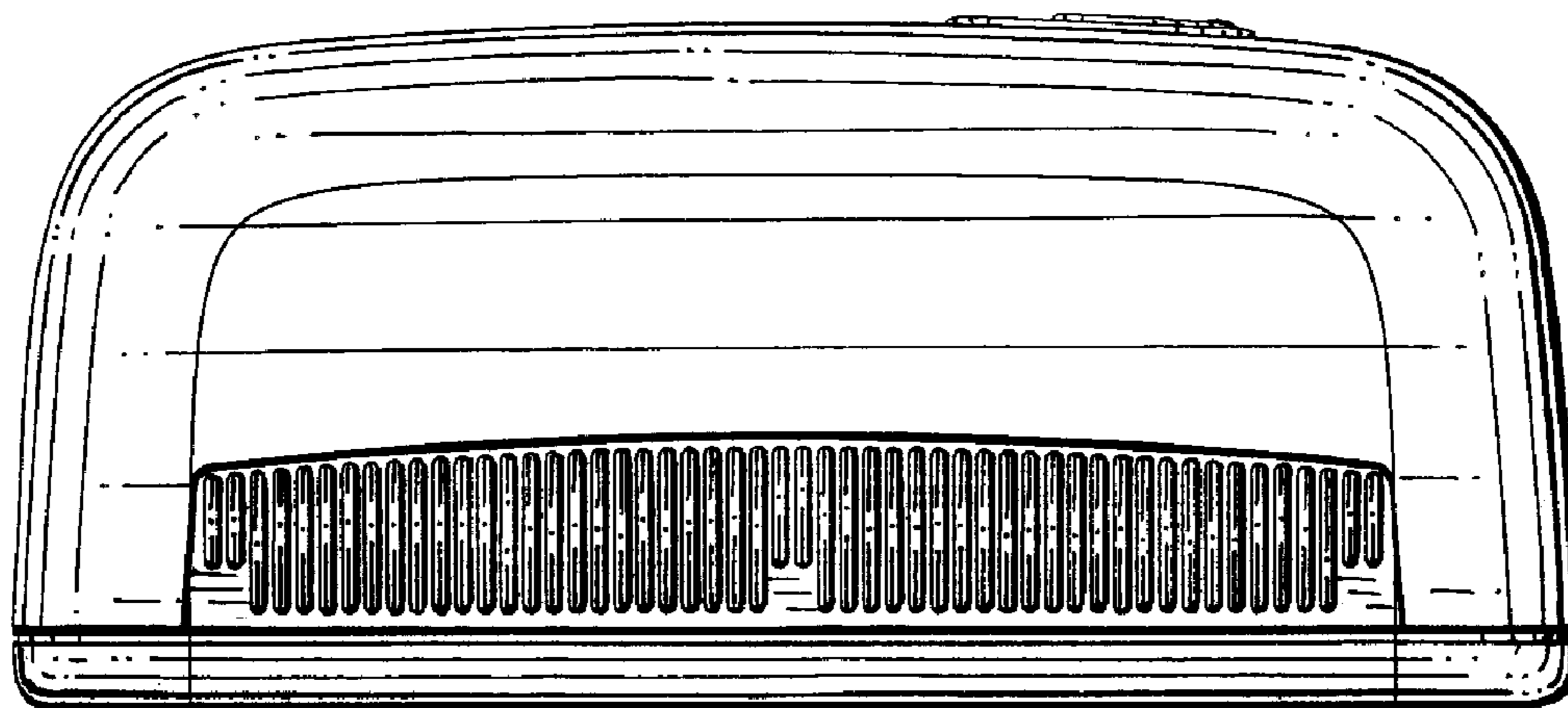

FIG. 4

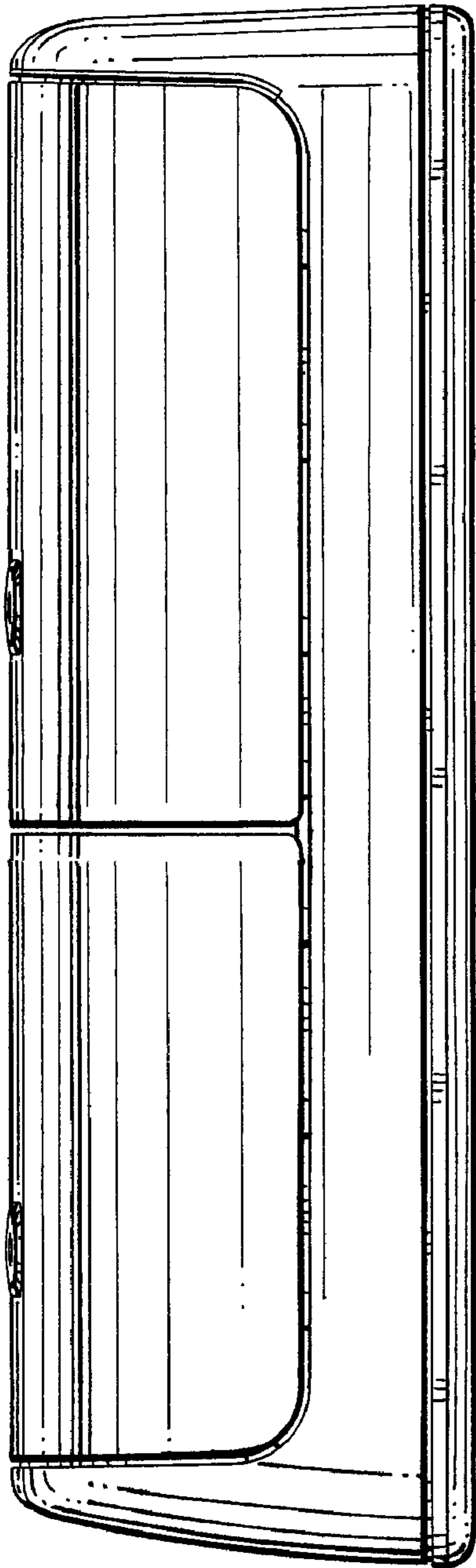

FIG. 5

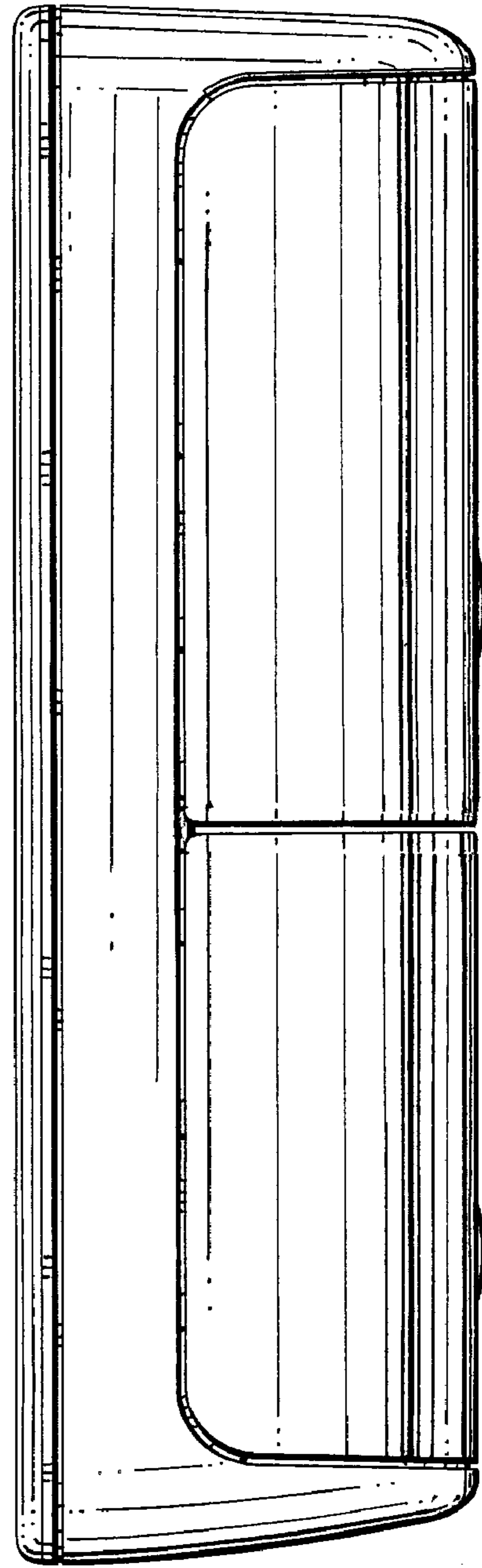

FIG. 6

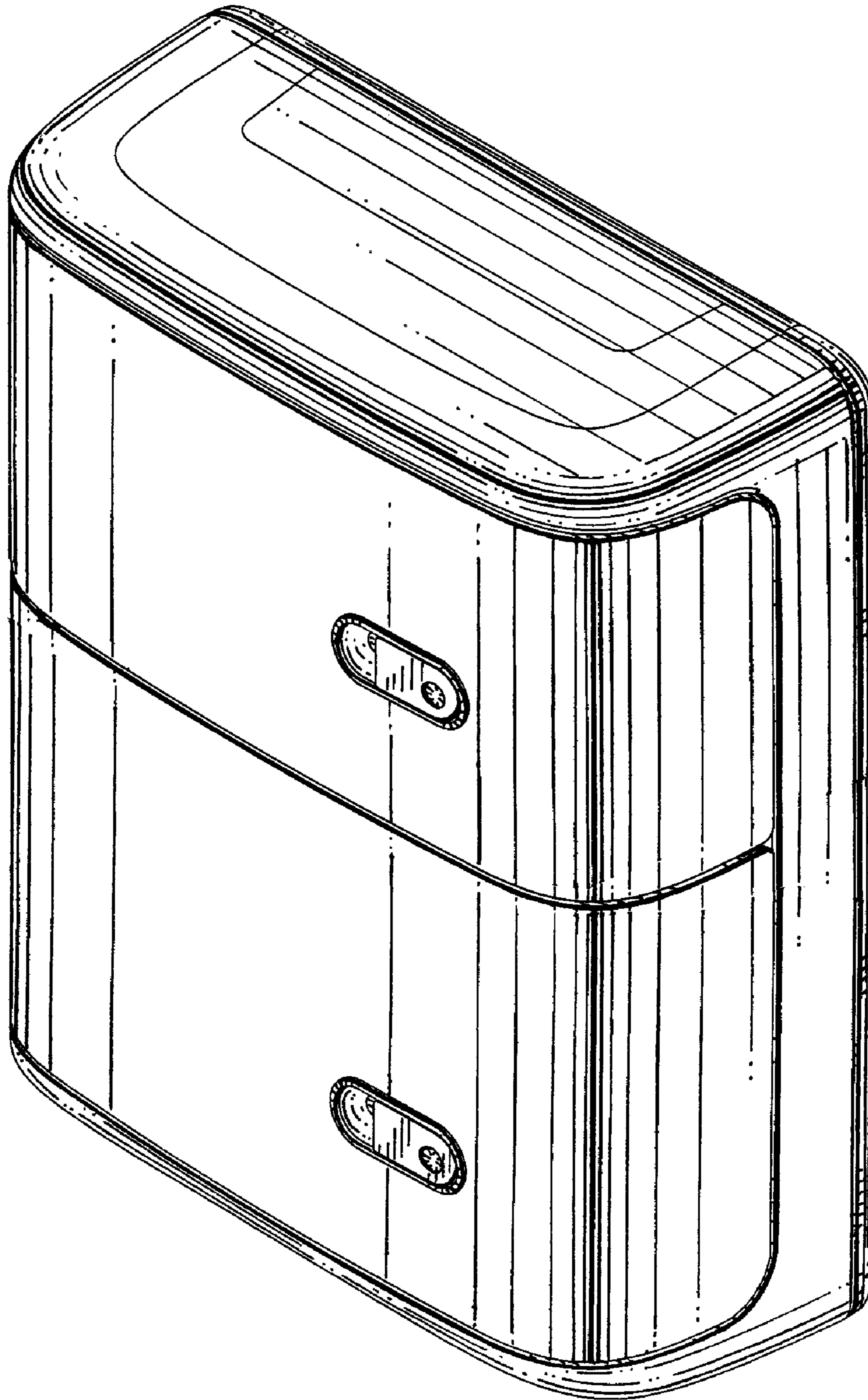

FIG. 7

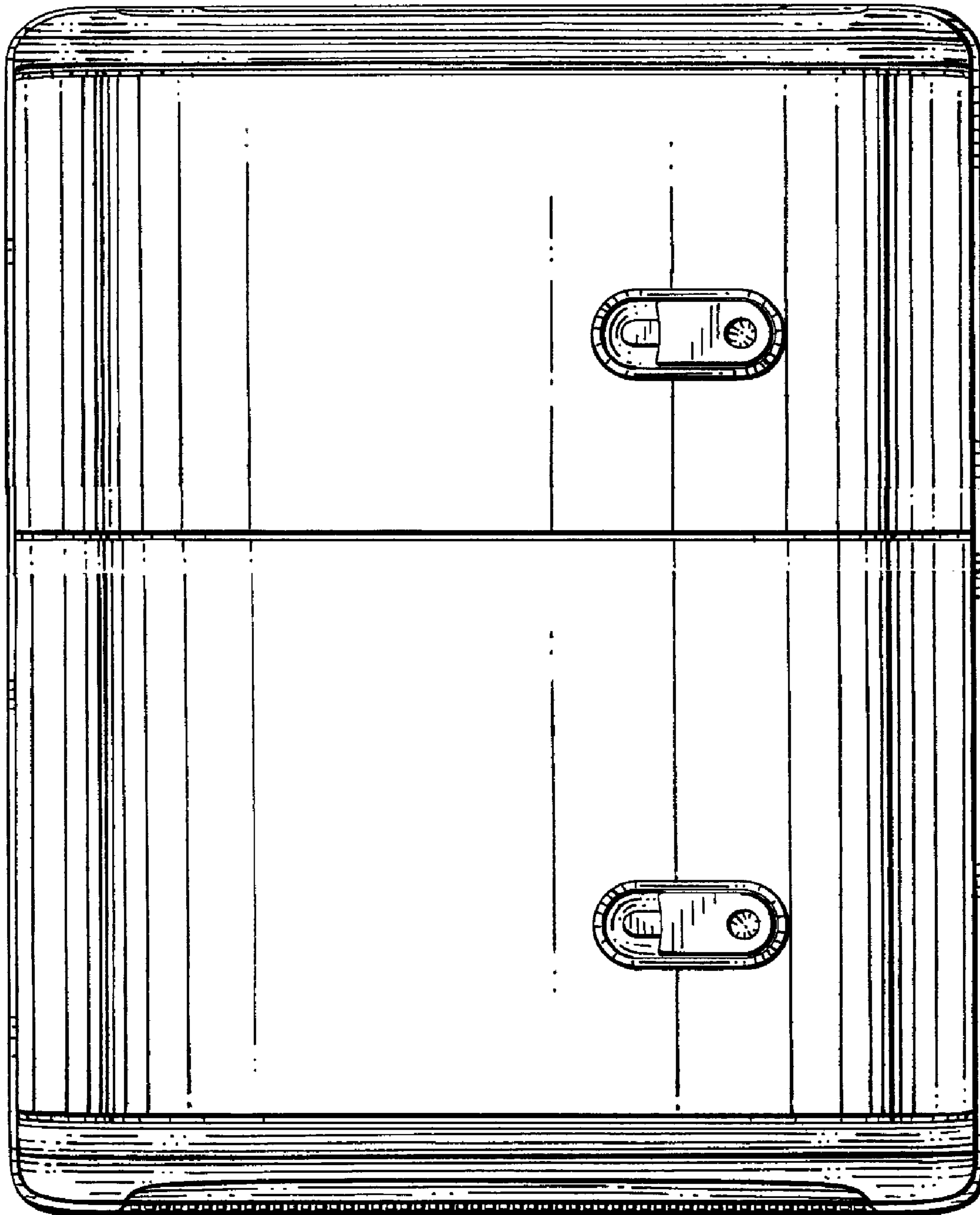

FIG.8

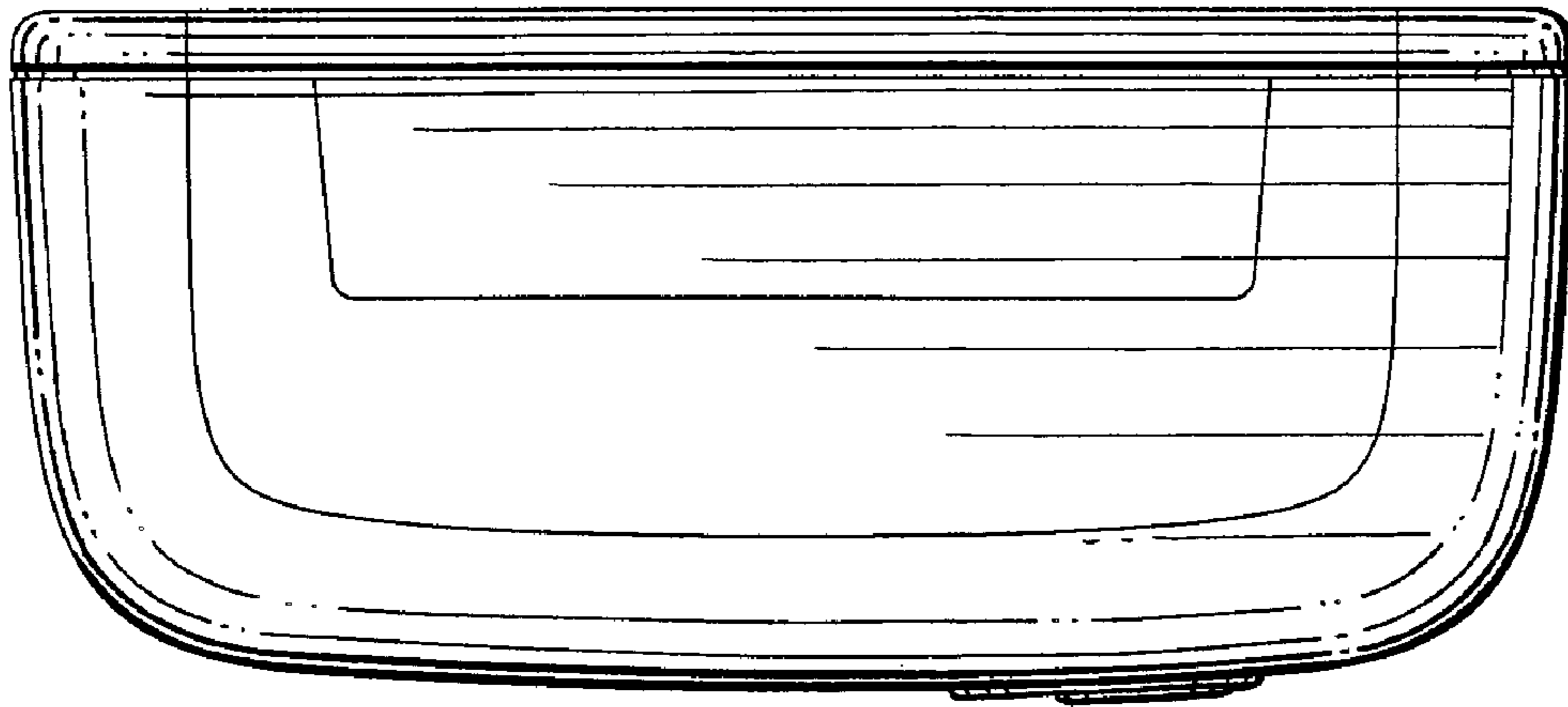

FIG. 9

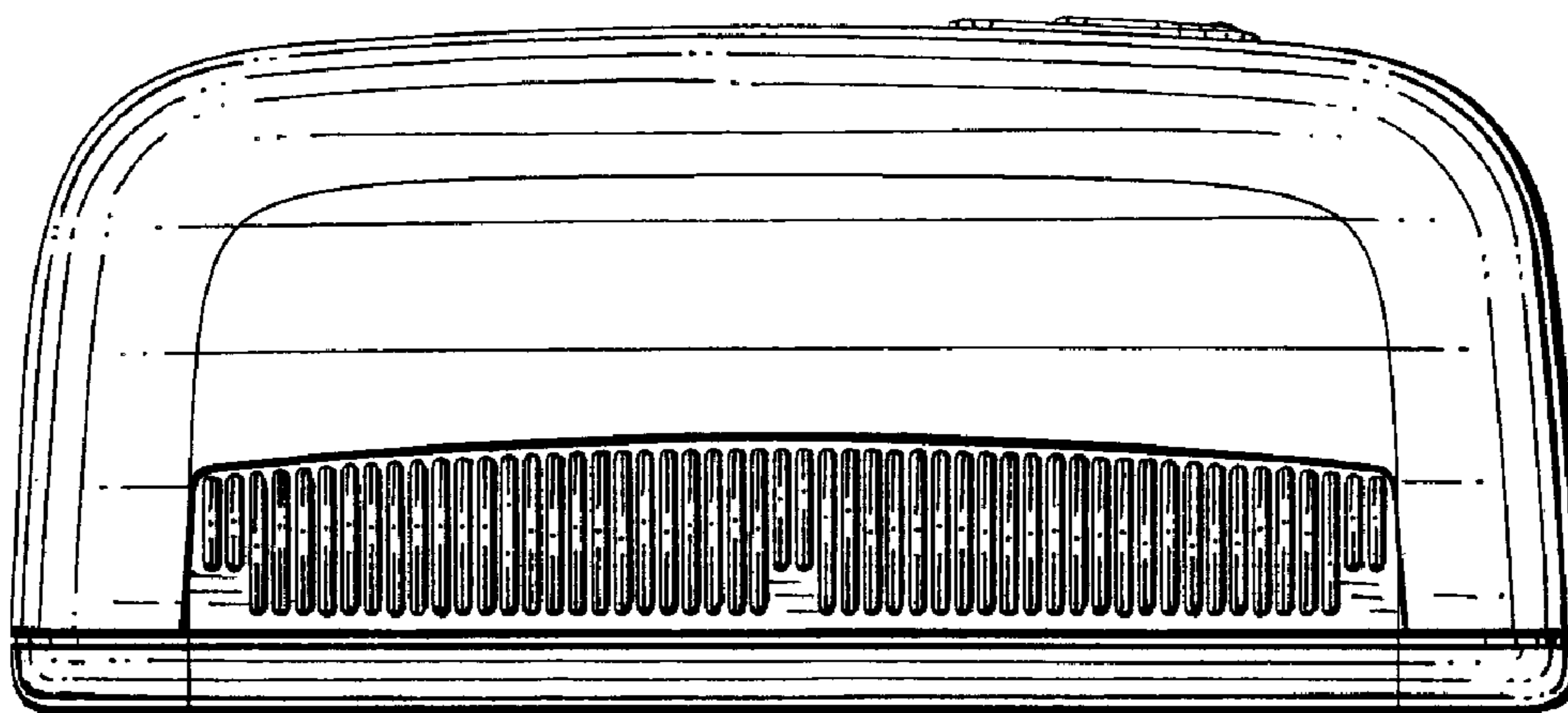

FIG. 12

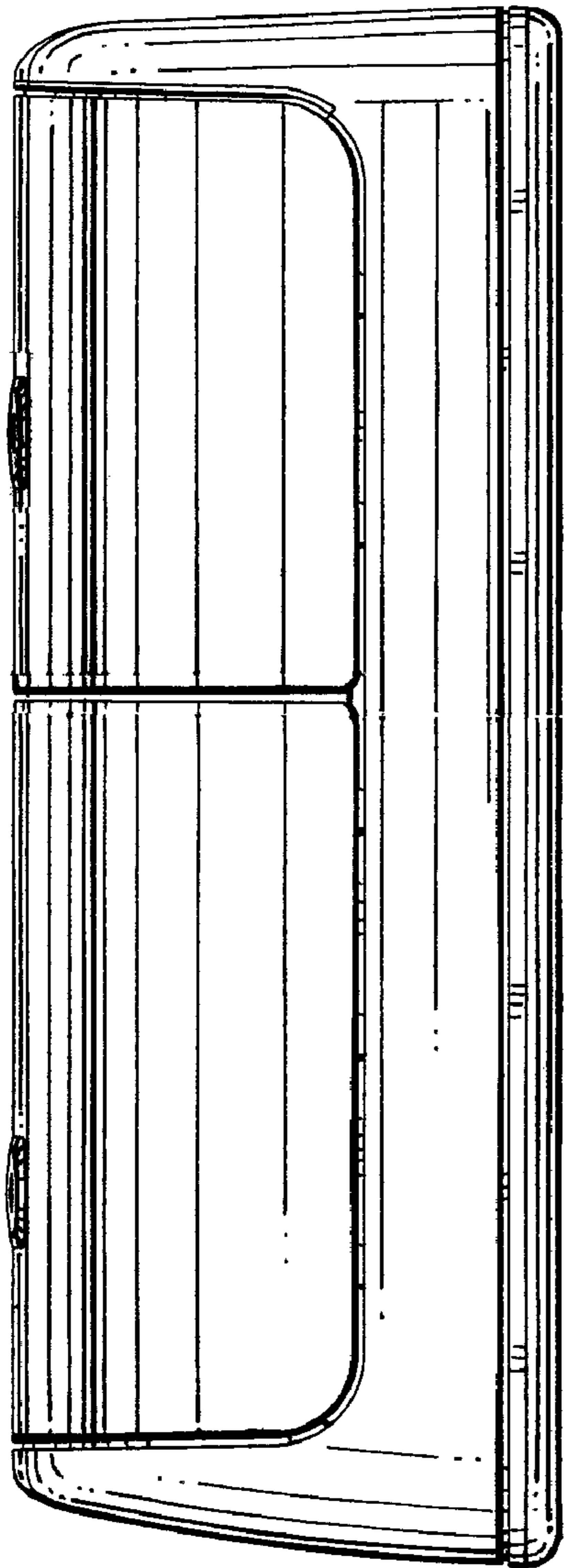

FIG. 10

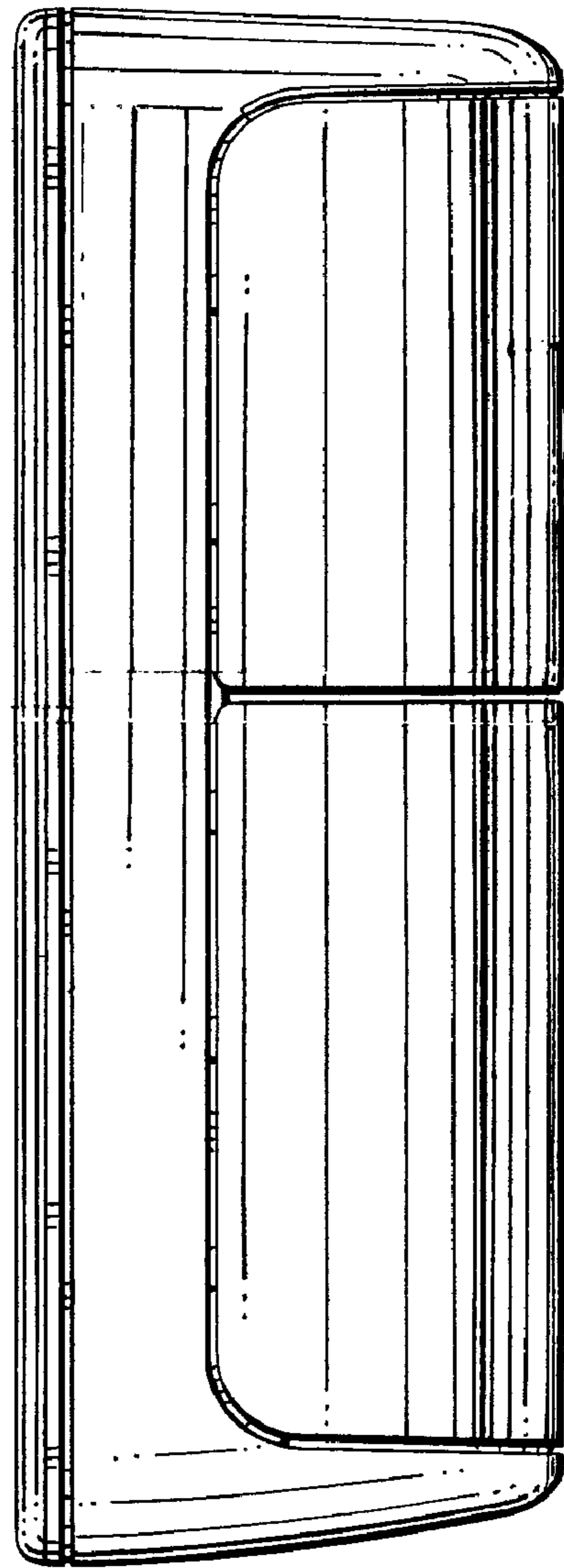

FIG. 11