



US00D615007S

(12) **United States Design Patent**  
**Kasai et al.**

(10) **Patent No.:** **US D615,007 S**  
(45) **Date of Patent:** **\*\* May 4, 2010**

(54) **RADIATOR GRILL FOR AUTOMOBILE**

D467,202 S \* 12/2002 Mondragon Sarmiento  
et al. .... D12/96  
D486,101 S \* 2/2004 Sun et al. .... D12/163

(75) Inventors: **Gou Kasai**, Kanagawa (JP); **Takashi Noguchi**, Kanagawa (JP); **Matthew Weaver**, London (GB)

\* cited by examiner

(73) Assignee: **Nissan Jidosha Kabushiki Kaisha**,  
Yokohama-shi, Kanagawa-ken (JP)

*Primary Examiner*—Melody N Brown  
(74) *Attorney, Agent, or Firm*—Fross Zelnick Lehrman &  
Zissu, P.C.; Lawrence E. Apolzon, Esq.

(\*\*) Term: **14 Years**

(57) **CLAIM**

(21) Appl. No.: **29/316,234**

The ornamental design for a radiator grill for automobile, as shown and described.

(22) Filed: **Sep. 3, 2009**

(30) **Foreign Application Priority Data**

**DESCRIPTION**

Jul. 14, 2009 (JP) ..... 2009-016060

FIG. 1 is a perspective view of the front, right and top of a radiator grill for automobile showing our new design;

(51) **LOC (9) Cl.** ..... **12-16**

FIG. 2 is a front view thereof;

(52) **U.S. Cl.** ..... **D12/163; D12/169**

FIG. 3 is a rear view thereof;

(58) **Field of Classification Search** ..... D12/163,  
D12/196, 90-92, 86, 171, 169, 216; 180/68.1,  
180/68.6; 296/193.11

FIG. 4 is a left side view thereof;

FIG. 5 is a right side view thereof;

See application file for complete search history.

FIG. 6 is a top plan view thereof; and,

FIG. 7 is a bottom view thereof.

(56) **References Cited**

The elements shown in broken lines are of illustrative purposes only and form no part of the claimed design.

**U.S. PATENT DOCUMENTS**

D293,230 S \* 12/1987 Kawaoka ..... D12/163  
D394,035 S \* 5/1998 Stosel et al. .... D12/163

**1 Claim, 6 Drawing Sheets**

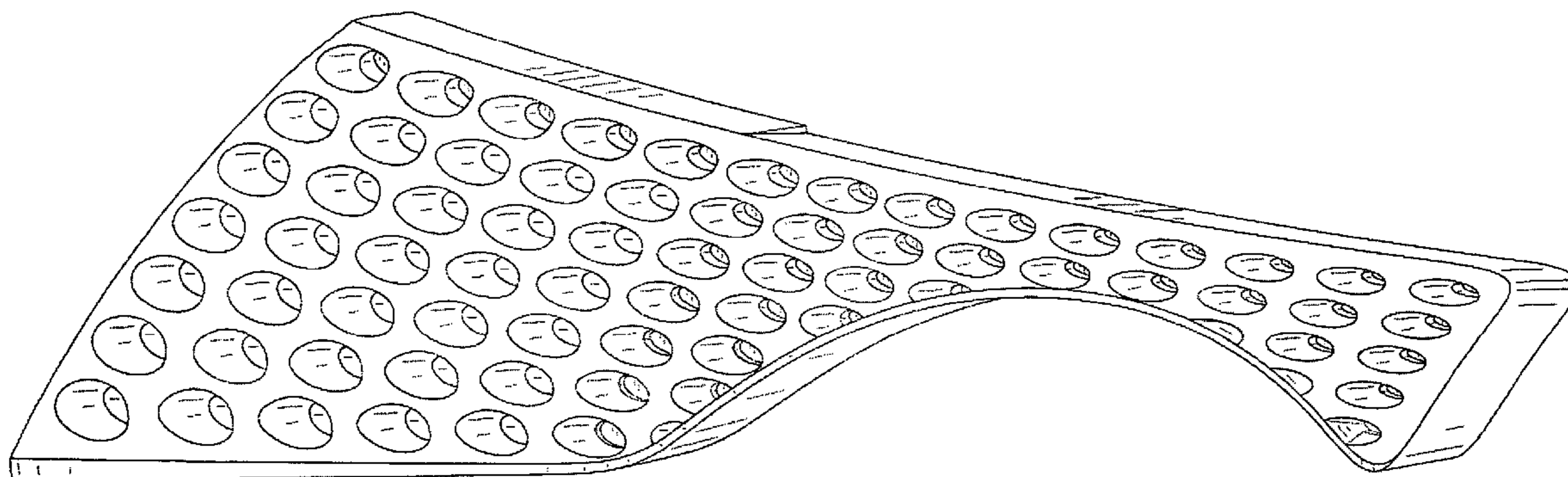

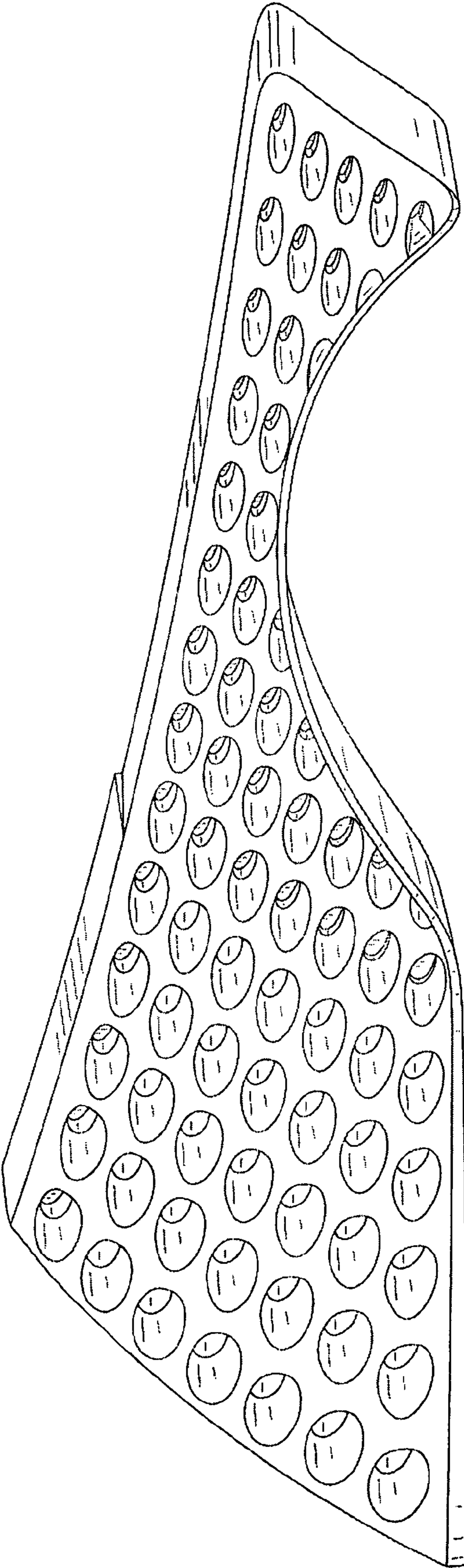

FIG. 1

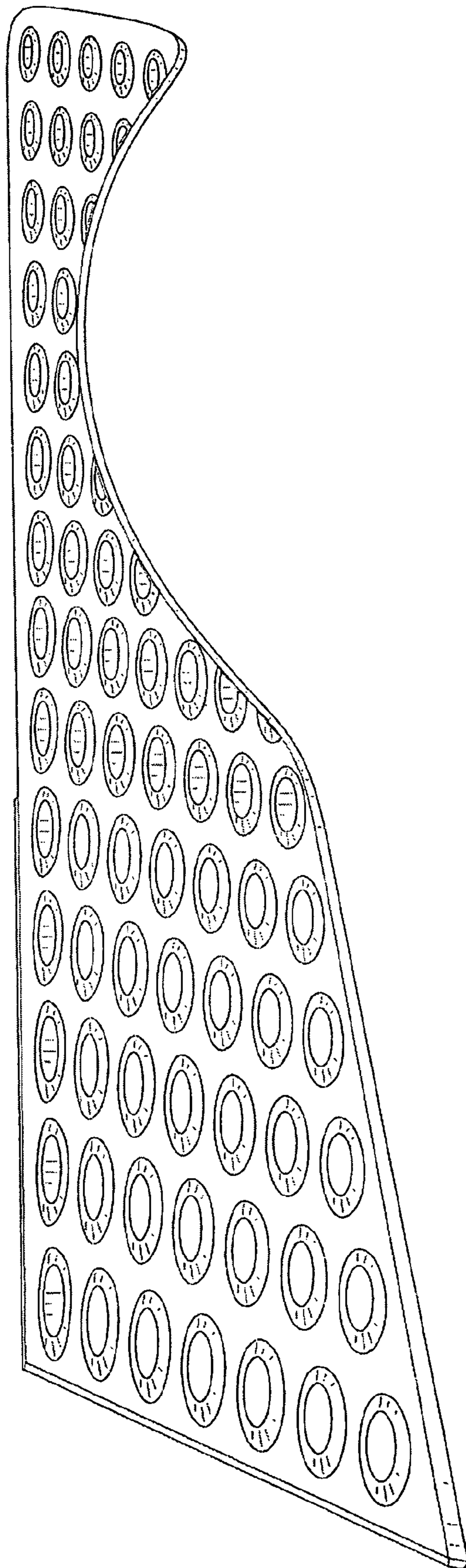

FIG. 2

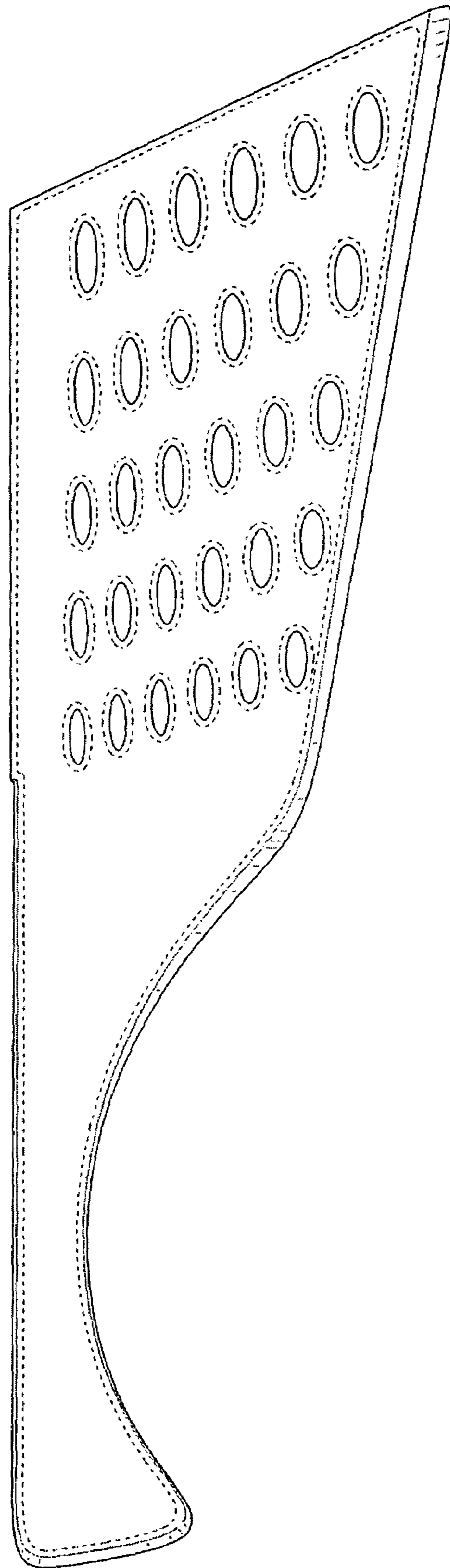
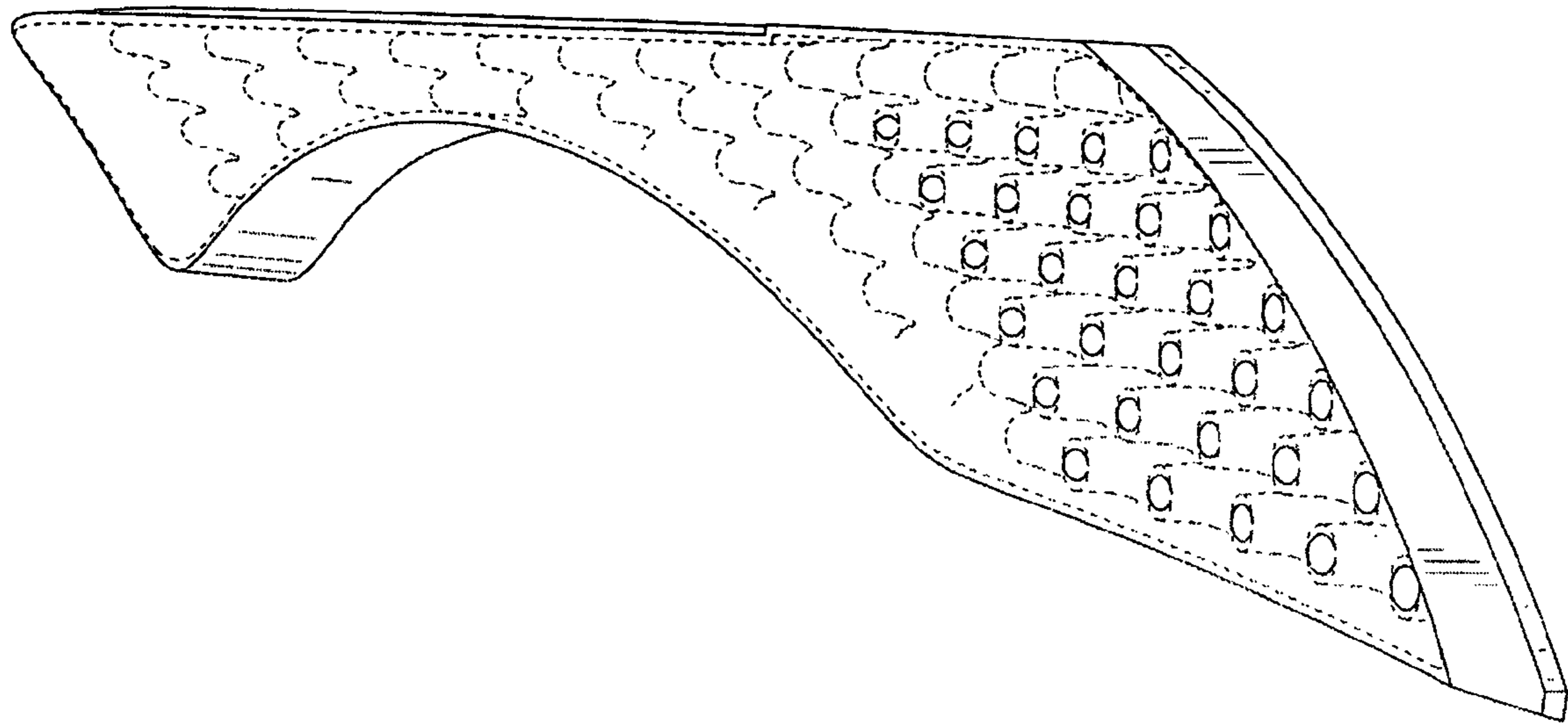
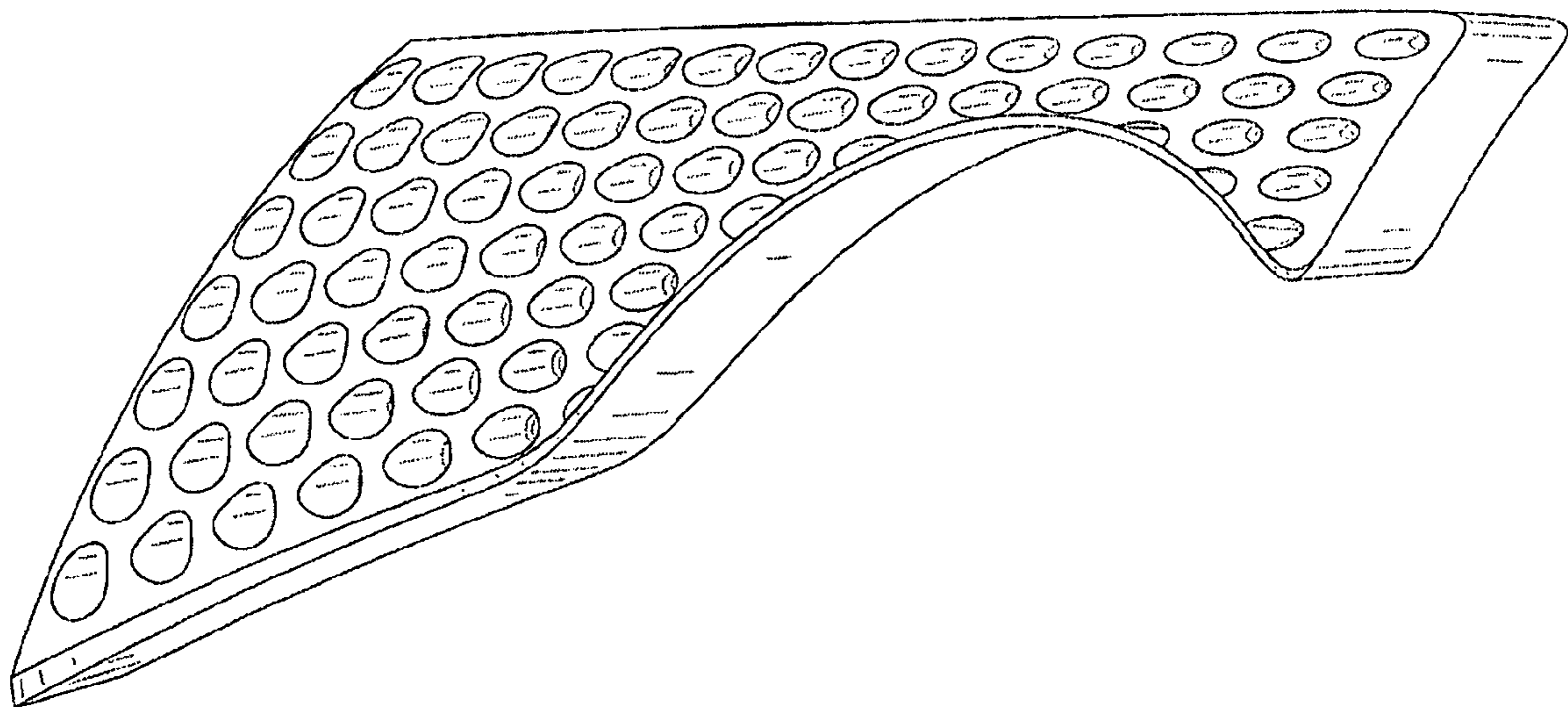

FIG. 3



**FIG. 4**



**FIG. 5**

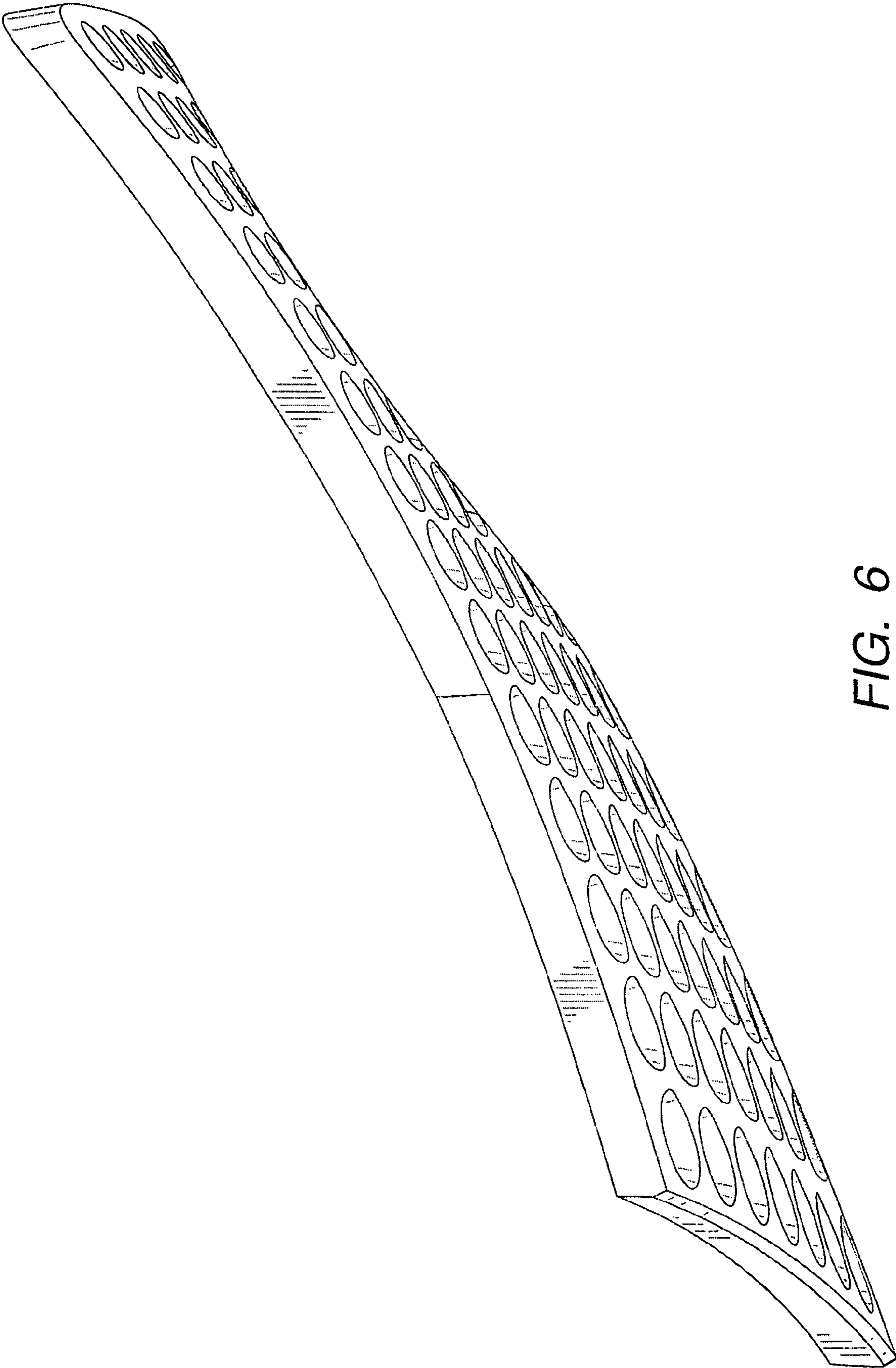

FIG. 6

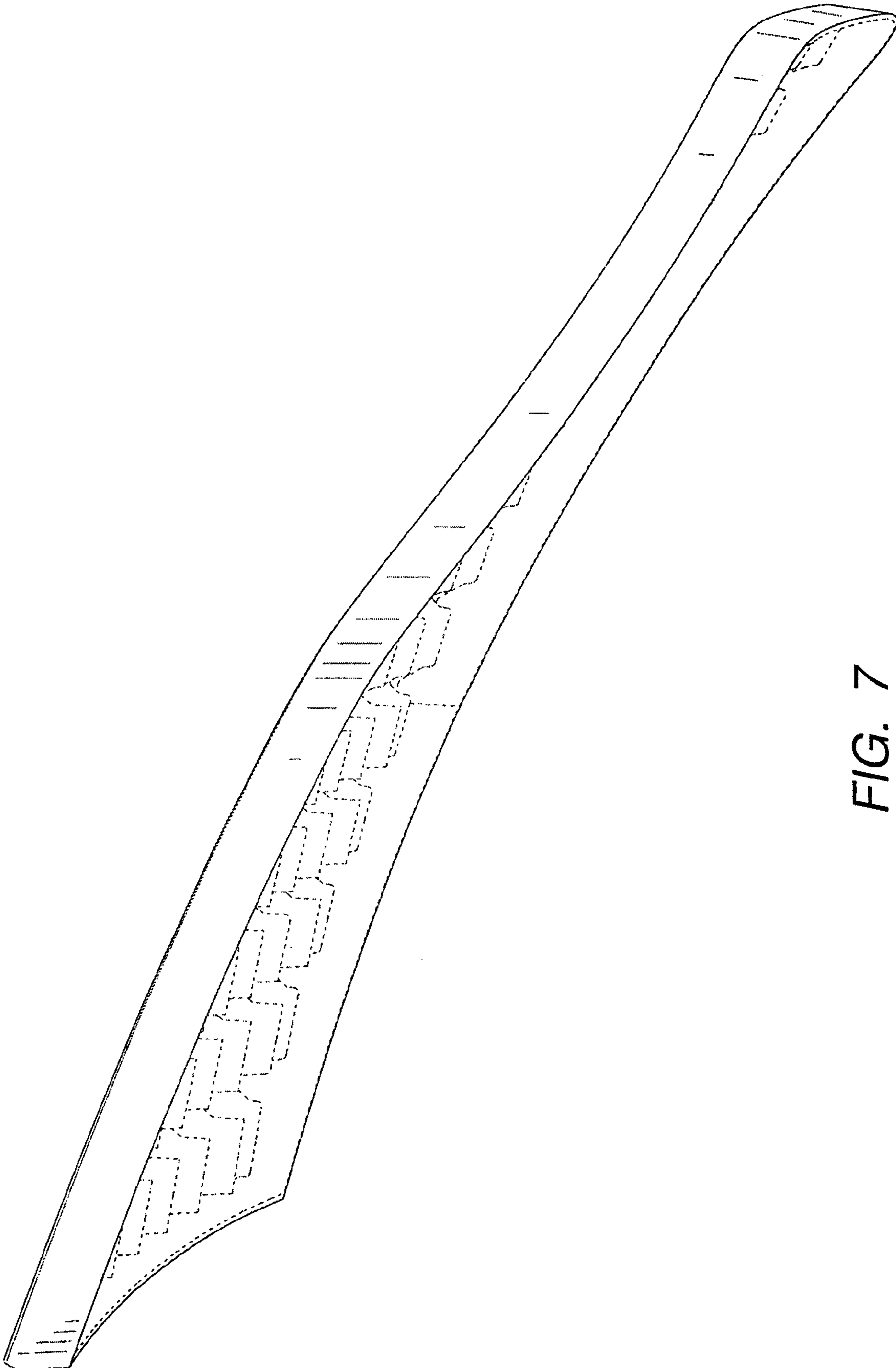

FIG. 7