



US00D614986S

(12) **United States Design Patent**  
**Shin**

(10) **Patent No.:** **US D614,986 S**

(45) **Date of Patent:** **\*\* May 4, 2010**

(54) **MIRRORED LIGHT BAR SET FOR EMERGENCY VEHICLES**

7,394,398 B2 7/2008 Pederson  
D592,089 S \* 5/2009 Shin ..... D10/114  
2008/0080203 A1 \* 4/2008 Neufeglise ..... 362/540

(76) Inventor: **David D Shin**, 7322 Madison St.,  
Paramount, CA (US) 90723

\* cited by examiner

(\*\*) Term: **14 Years**

*Primary Examiner*—Caron Veynar

*Assistant Examiner*—George D Kirschbaum

(21) Appl. No.: **29/341,525**

(74) *Attorney, Agent, or Firm*—Kirk A. Buhler; Buhler & Associates

(22) Filed: **Aug. 6, 2009**

(57) **CLAIM**

(51) **LOC (9) Cl.** ..... **10-05**

The ornamental design for a mirrored light bar set for emergency vehicles, as shown and described.

(52) **U.S. Cl.** ..... **D10/114**

(58) **Field of Classification Search** ..... D10/114;  
D26/72, 85; 362/540–549

**DESCRIPTION**

See application file for complete search history.

FIG. 1 is a top, left perspective view of a mirrored light bar set for emergency vehicles showing my new design;

(56) **References Cited**

**U.S. PATENT DOCUMENTS**

2,814,029	A	11/1957	McRea	
3,278,741	A	10/1966	Wood	
D249,250	S	9/1978	Peirisj, Jr.	
4,357,595	A	11/1982	Gosswiller	
D274,001	S	5/1984	Sailers	
4,620,268	A	10/1986	Ferenc	
4,937,711	A	6/1990	Shuen	
4,956,753	A	9/1990	Renfrew	
D324,921	S	3/1992	Stanuch et al.	
D355,142	S	2/1995	Wagner	
D400,675	S	11/1998	Sopko	
RE36,245	E *	7/1999	Stanuch et al. ....	362/480
D419,249	S	1/2000	Ford et al.	
D442,106	S	5/2001	Stein et al.	
6,461,008	B1	10/2002	Pederson	
6,511,216	B2 *	1/2003	Strickland .....	362/542
6,590,502	B1	7/2003	Pederson	
6,623,151	B2	9/2003	Pederson	
6,788,217	B2	9/2004	Pederson	
6,789,930	B2	9/2004	Pederson	
6,814,459	B2	11/2004	Pederson	
6,822,578	B2	11/2004	Pederson	
7,033,036	B2	4/2006	Pederson	

FIG. 2 is a front, top right perspective view of the right unit, as seen in FIG. 1, the left unit being a mirror image thereof;

FIG. 3 is a top, left, perspective view of the right unit, as seen in FIG. 1, the left unit being a mirror image thereof;

FIG. 4 is a top view thereof;

FIG. 5 is a bottom view thereof;

FIG. 6 is a front view thereof;

FIG. 7 is a back view thereof;

FIG. 8 is a right side view of the left unit, the right unit having a mirror image view thereof;

FIG. 9 is a left side view of the right unit, the left unit having a mirror image view thereof; and,

FIG. 10 is environmental of the claimed design.

The broken lines in FIGS. 1 and 4–10 depict mounting hardware environmental subject matter and form no part of the claimed design.

The broken lines in FIG. 10 depict environmental subject matter of a vehicle and form no part of the claimed design.

**1 Claim, 6 Drawing Sheets**

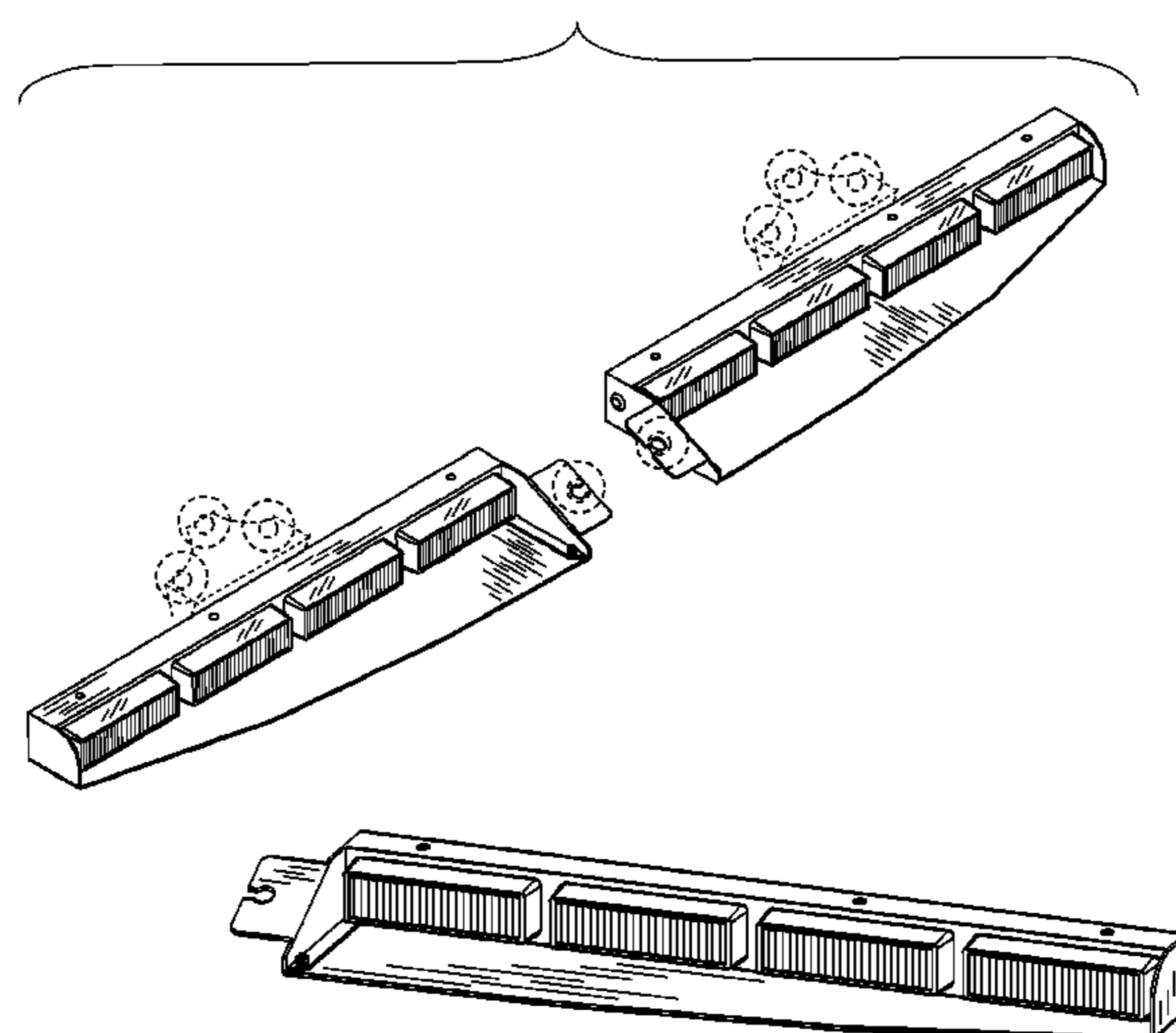

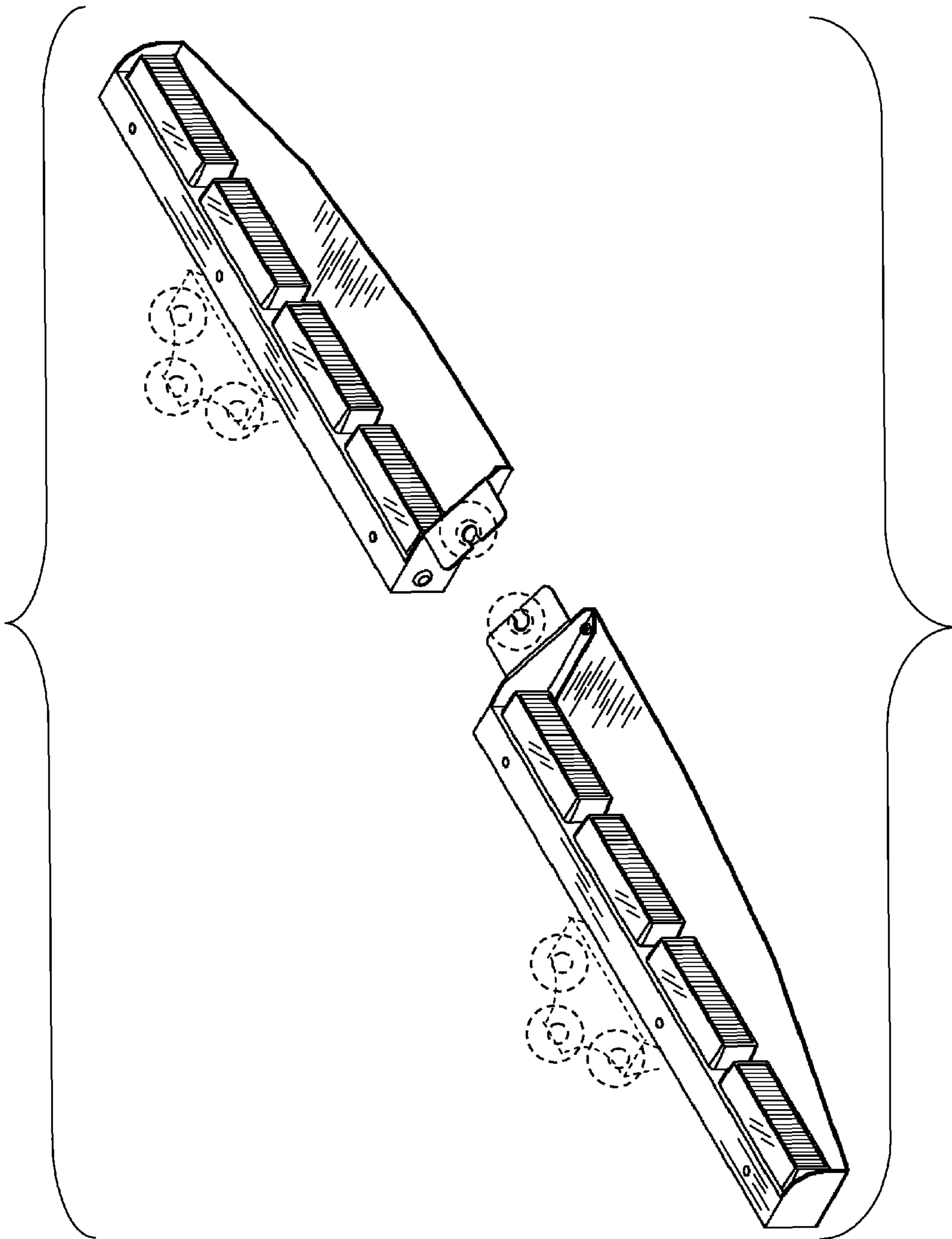

FIG. 1

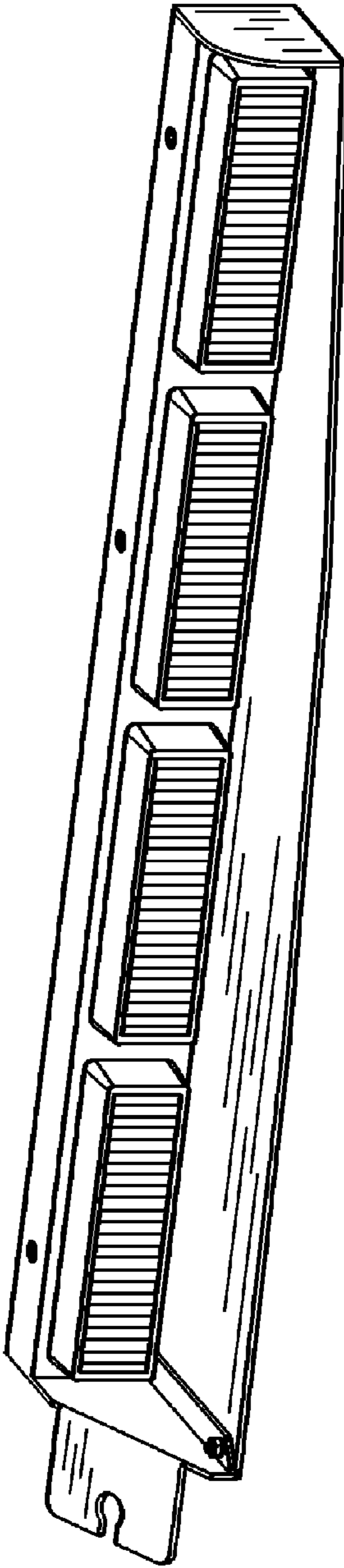

FIG. 2

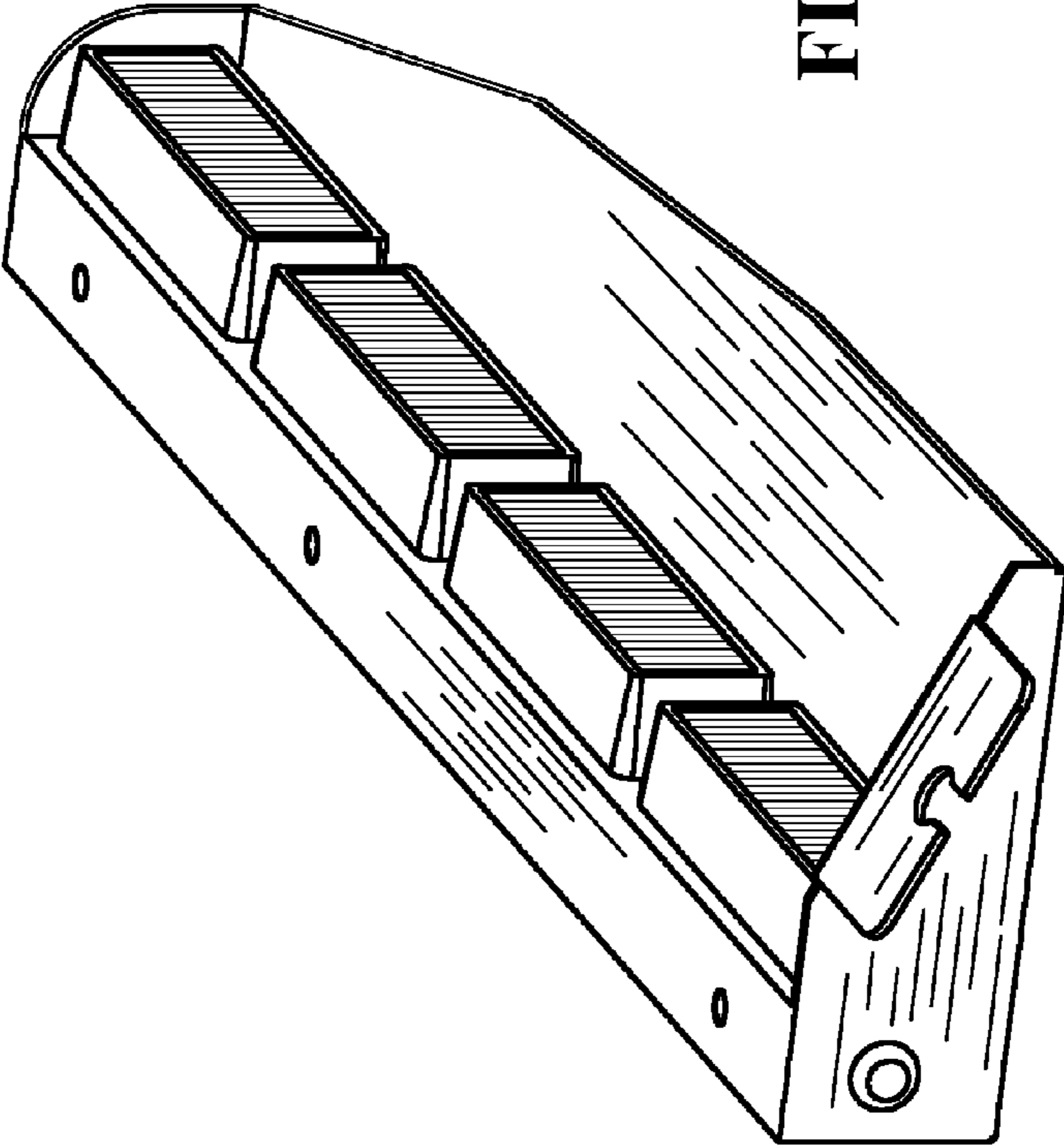

FIG. 3

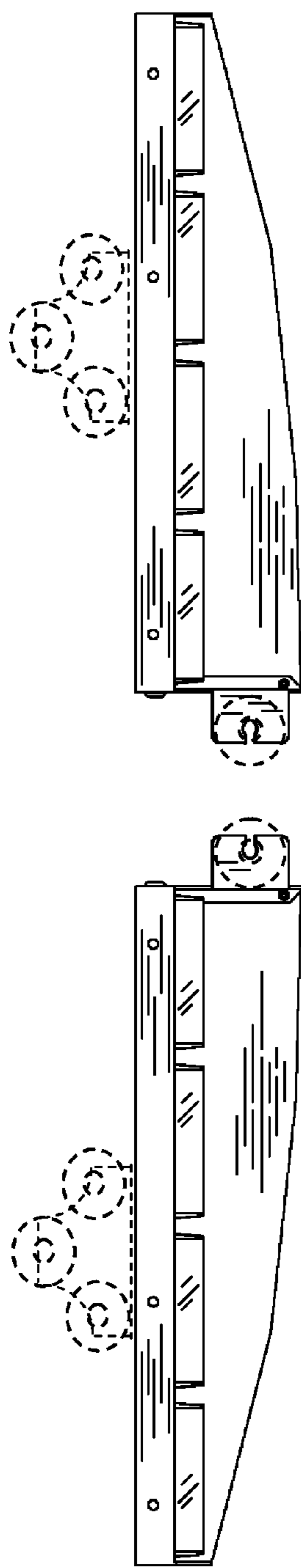

FIG. 4

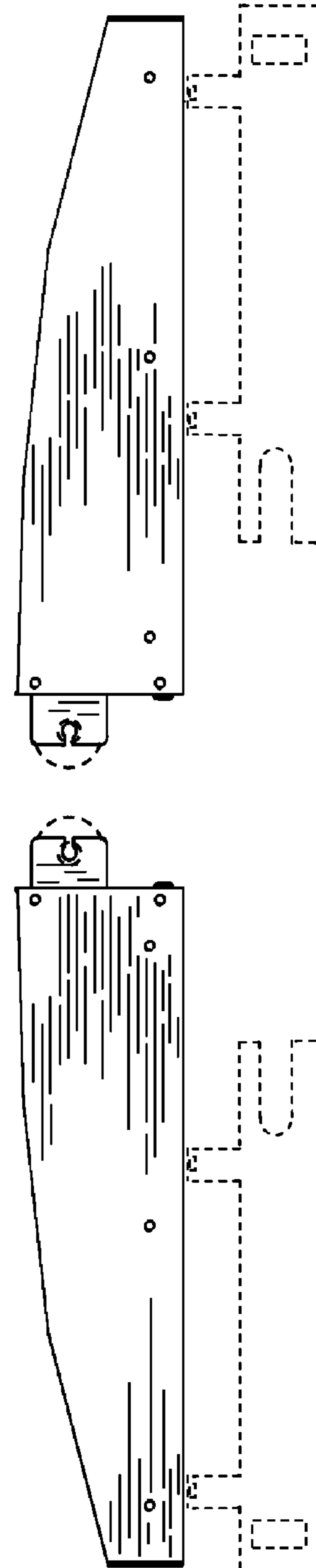

FIG. 5

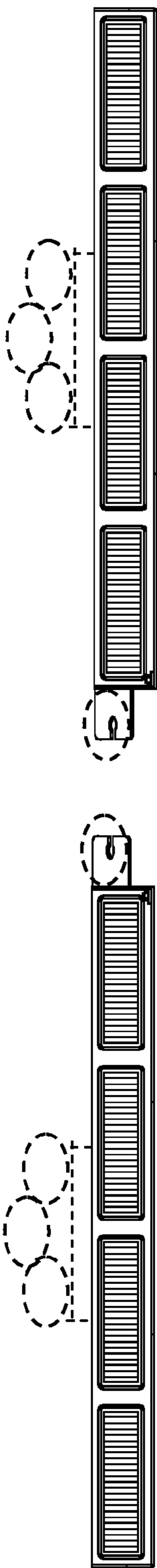

FIG. 6

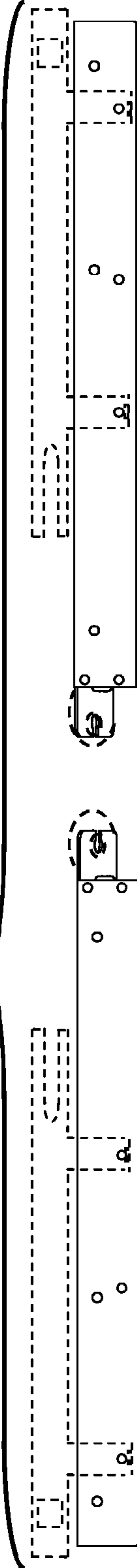

FIG. 7

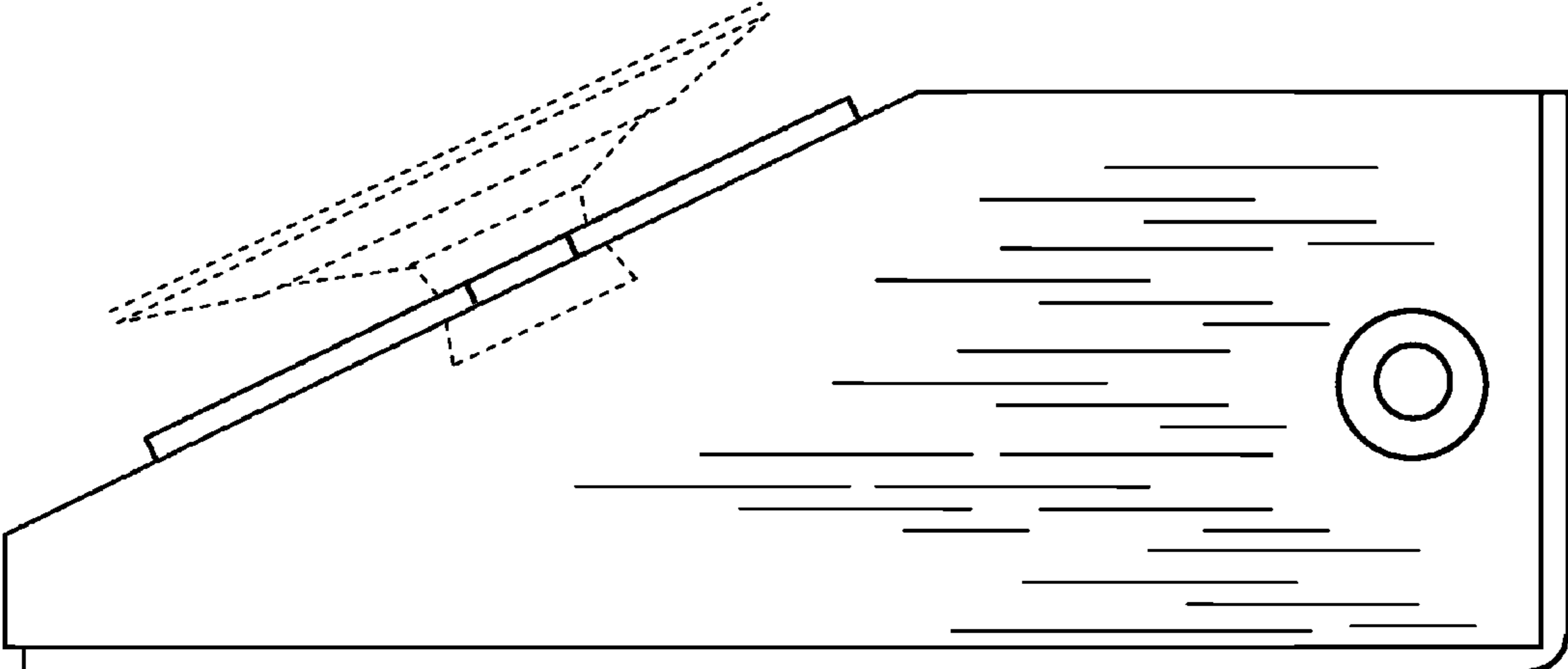

FIG. 8

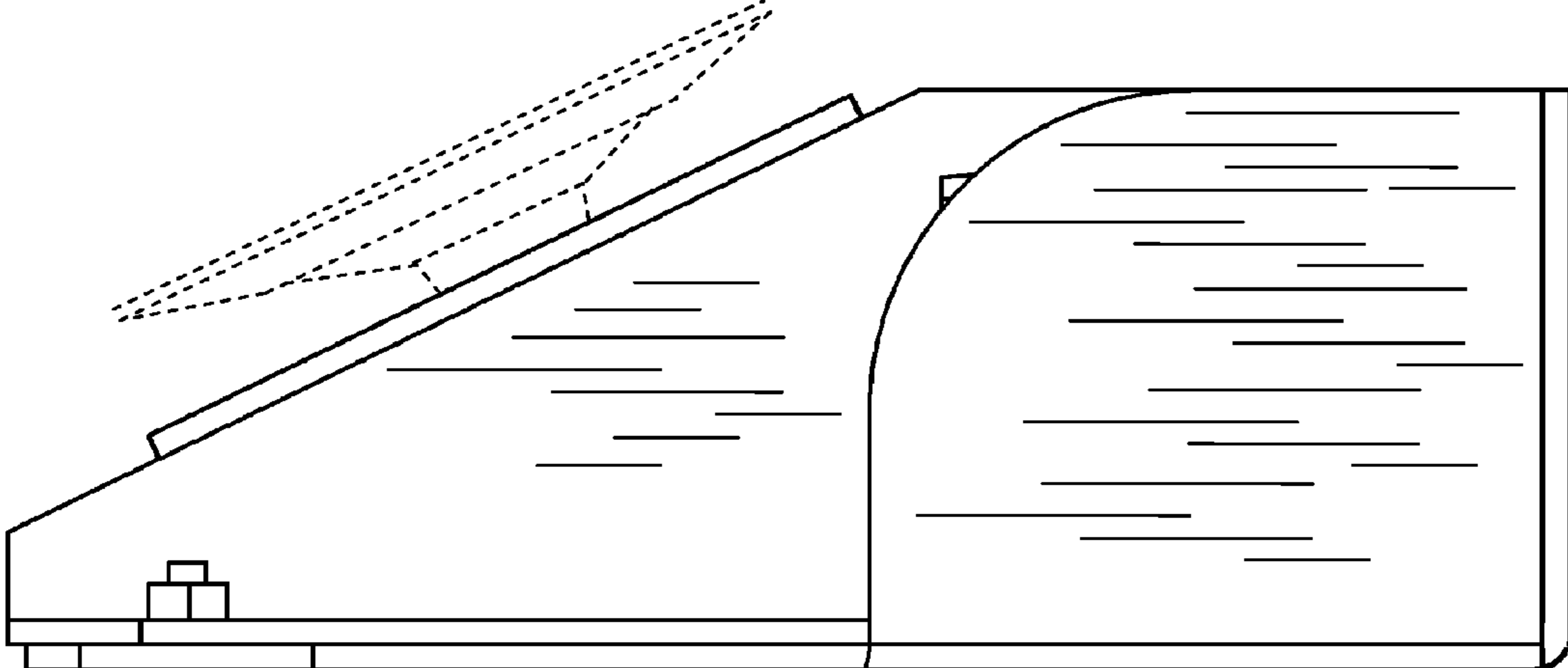

FIG. 9

