



US00D614940S

(12) **United States Design Patent**  
**Gaska et al.**

(10) **Patent No.:** **US D614,940 S**

(45) **Date of Patent:** **\*\* May 4, 2010**

(54) **ARM FOR AN ACTUATABLE HOLDING SYSTEM**

6,202,267 B1 \* 3/2001 Collins et al. .... 24/598.5

\* cited by examiner

(75) Inventors: **Gilius A. Gaska**, Saint Joseph, MI (US);  
**Michael J. Scherzer**, Saint Joseph, MI (US)

*Primary Examiner*—Holly H Baynham  
(74) *Attorney, Agent, or Firm*—Tara M. Hartman; McGarry Bair P.C.

(73) Assignee: **Whirlpool Corporation**, Benton Harbor, MI (US)

(57) **CLAIM**

The ornamental design for an arm for an actuatable holding system, as shown and described.

(\*\*) Term: **14 Years**

**DESCRIPTION**

(21) Appl. No.: **29/337,999**

FIG. 1 is a lower-front perspective view of the ornamental design for an entire configuration for an actuatable holding system according to the invention, with the arms shown in a closed position.

(22) Filed: **Jun. 3, 2009**

FIG. 2 is a lower-front perspective view of the ornamental design for an entire configuration for an actuatable holding system according to the invention, with the arms shown in an opened position.

(51) **LOC (9) Cl.** ..... **08-05**

(52) **U.S. Cl.** ..... **D8/373**

(58) **Field of Classification Search** ..... D8/354,  
D8/373; 248/316.5; 211/19, 68, 312

See application file for complete search history.

FIG. 3 is a front view thereof, with the rear view being identical; and,

(56) **References Cited**

**U.S. PATENT DOCUMENTS**

- 2,991,530 A \* 7/1961 Johnson et al. .... 24/598.5
- 3,014,257 A \* 12/1961 Huffman ..... 24/598.5
- 4,702,447 A \* 10/1987 Westwood, III ..... 248/231.51
- 5,802,889 A \* 9/1998 Arnold ..... 70/18
- 5,867,877 A \* 2/1999 Patterson et al. .... 24/598.5

FIG. 4 is a left side view thereof, with the right side view being identical.

The structures depicted by means of broken lines in the figures have been shown for illustrative purposes only and form no part of the claimed design. In particular, the body is shown in broken lines and the arms are shown in solid lines.

**1 Claim, 4 Drawing Sheets**

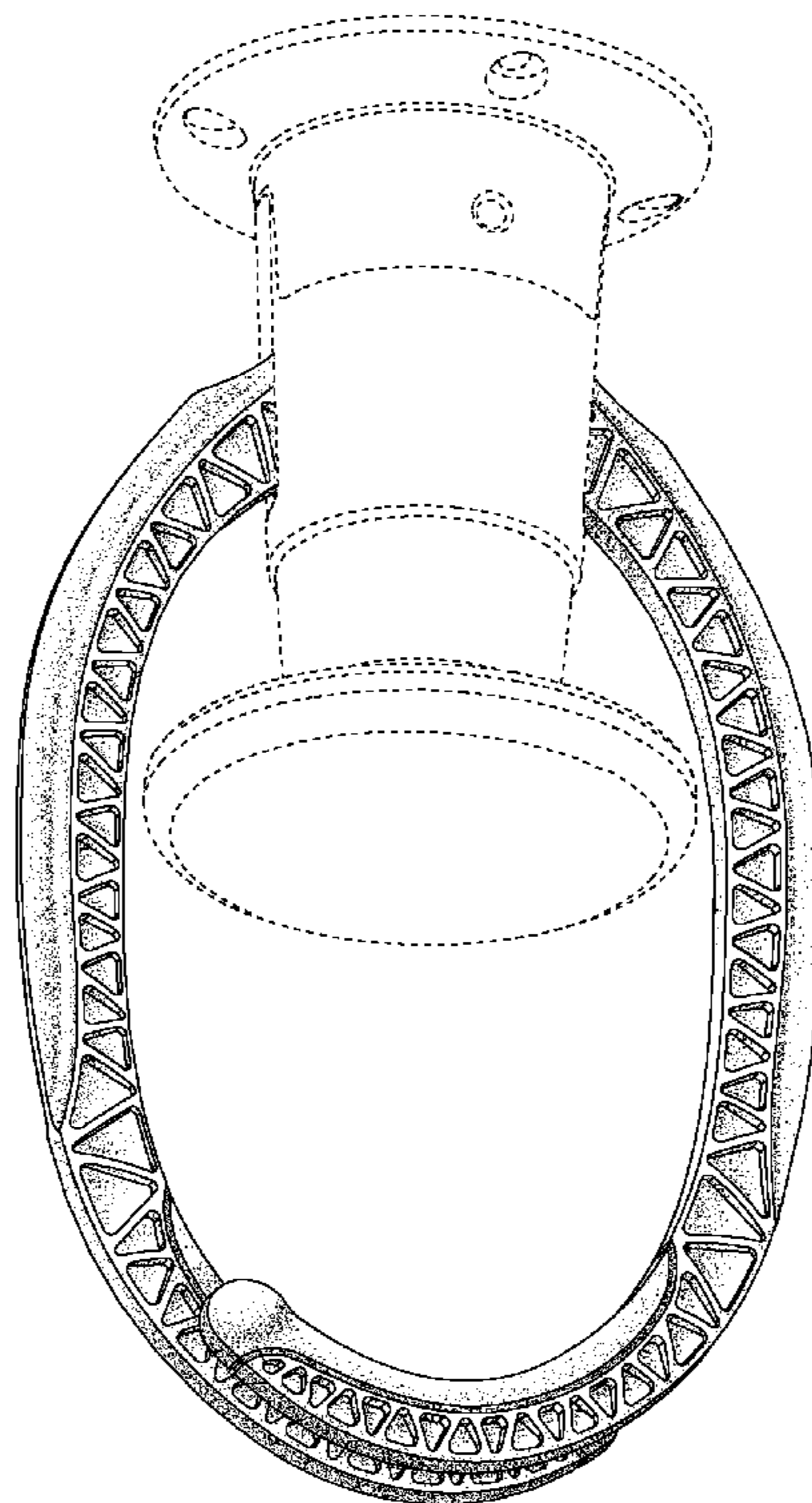

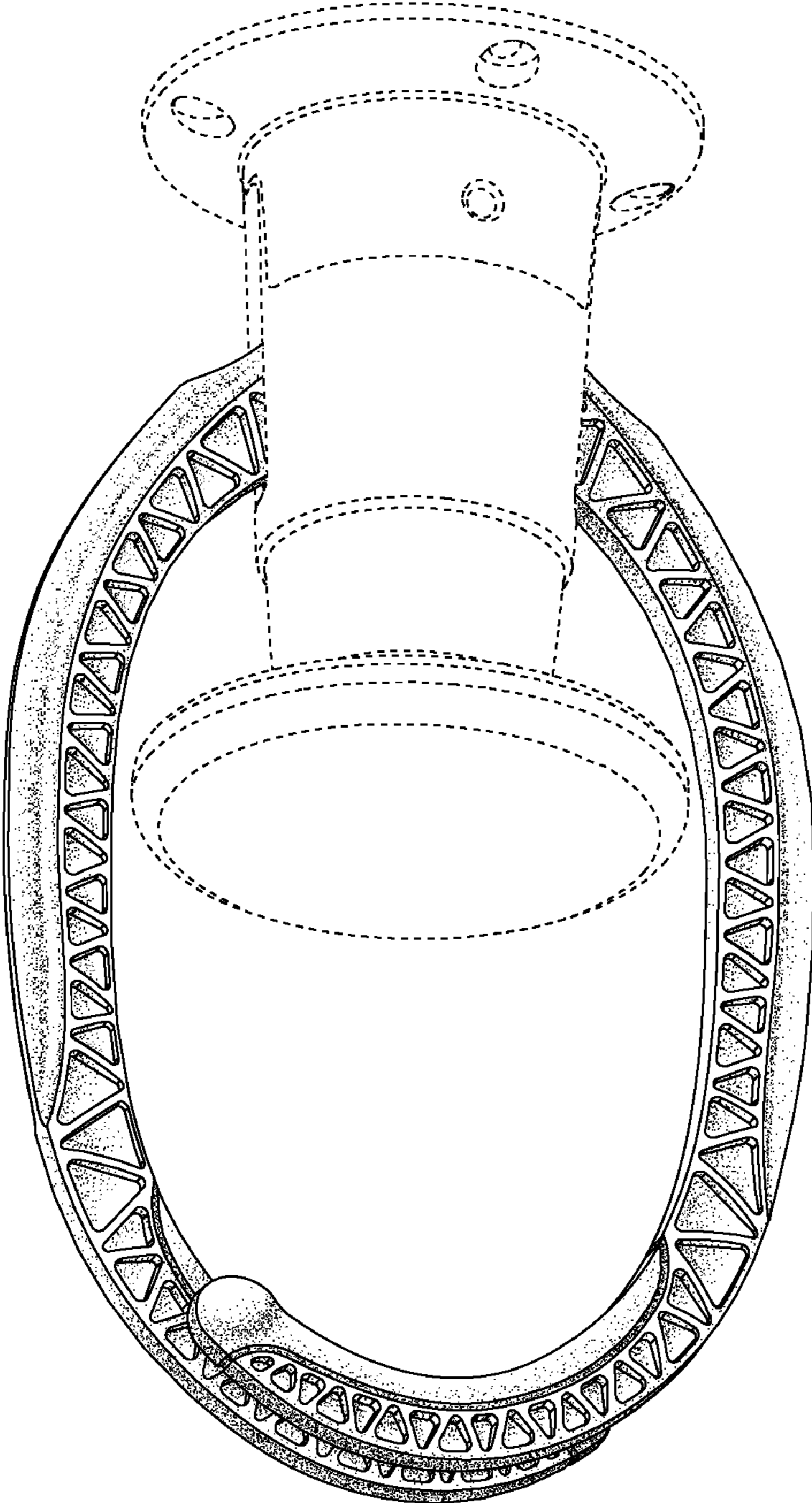

Fig. 1

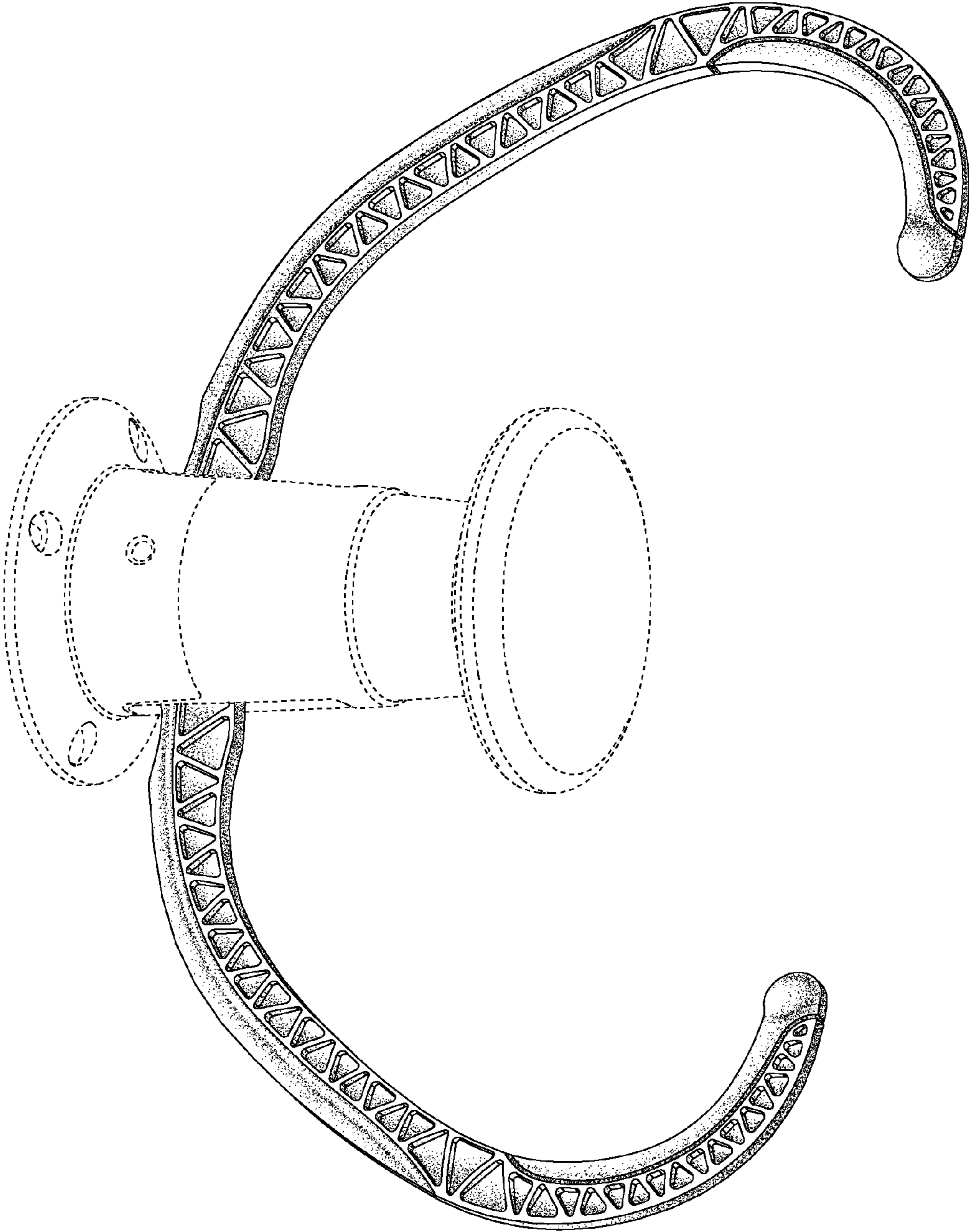

Fig. 2

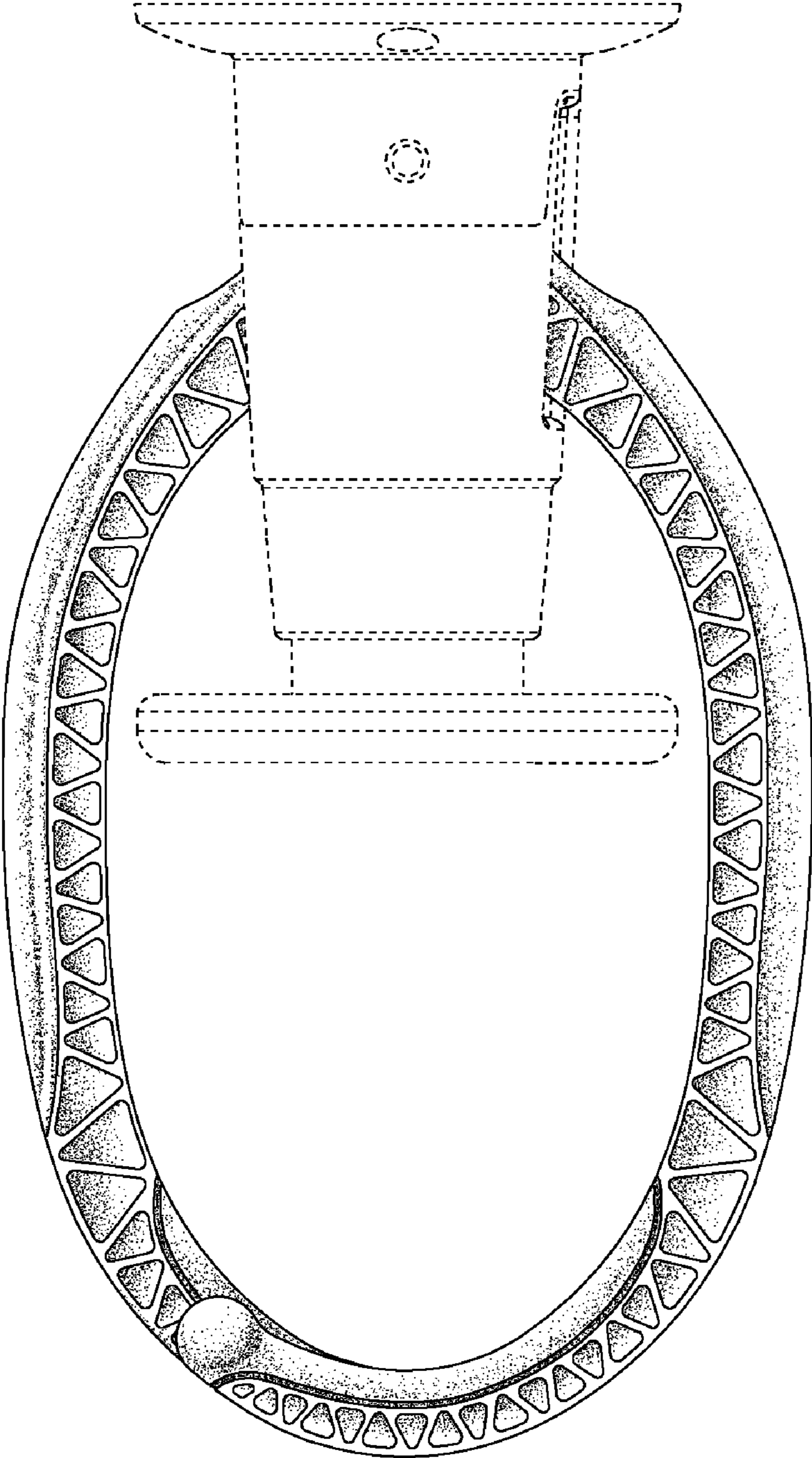

Fig 3

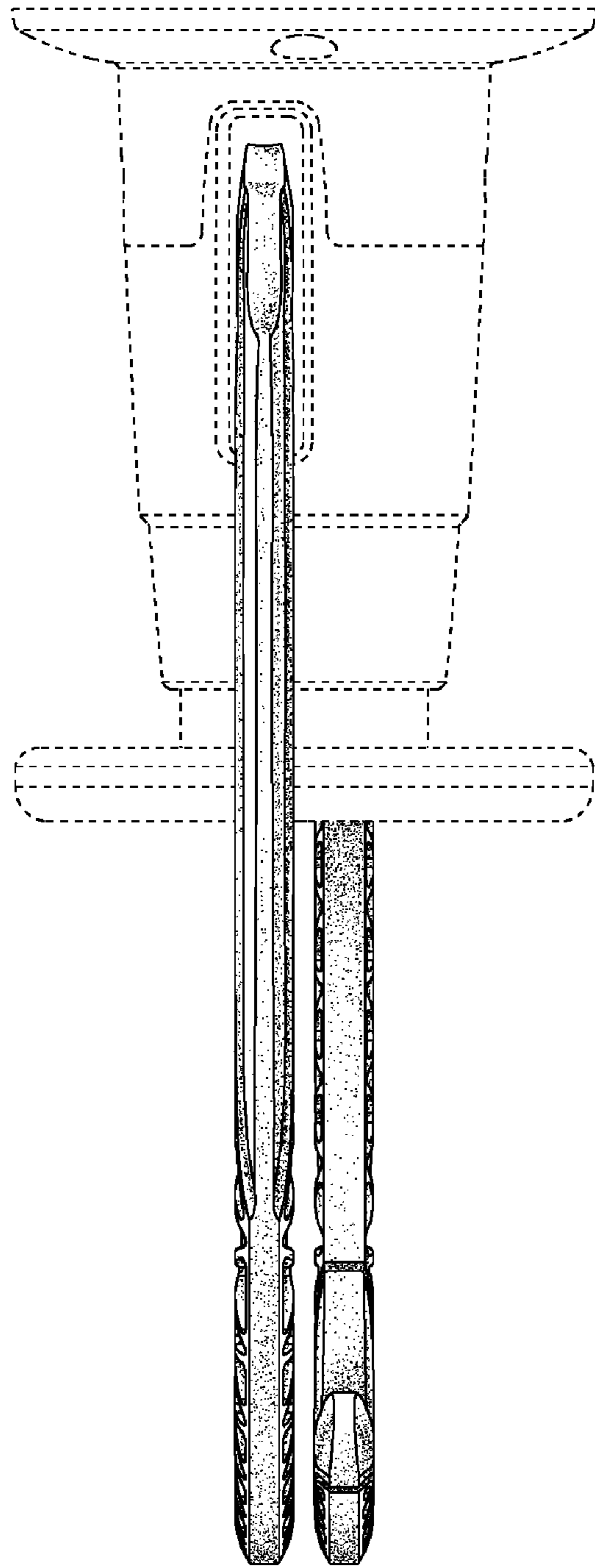

Fig. 4