



US00D614934S

(12) **United States Design Patent**
Cruz

(10) **Patent No.:** **US D614,934 S**

(45) **Date of Patent:** **** May 4, 2010**

(54) **HANDLE-GRIP ACCESSORY FOR
MOTORCYCLE PASSENGER**

(76) Inventor: **Alvin Cruz**, 105 15th St., #5, Brooklyn,
NY (US) 11215

(**) Term: **14 Years**

(21) Appl. No.: **29/336,732**

(22) Filed: **May 7, 2009**

(51) **LOC (9) Cl.** **12-11**

(52) **U.S. Cl.** **D8/303; D12/114**

(58) **Field of Classification Search** D8/303;
D12/114, 110, 178; 74/488, 489, 551.1-551.9;
D2/639; D29/100; 180/89.1, 312
See application file for complete search history.

(56) **References Cited**

U.S. PATENT DOCUMENTS

3,533,107	A *	10/1970	Americo et al.	2/83
3,896,499	A *	7/1975	Kelly	2/311
D245,816	S *	9/1977	Conti et al.	D29/101.5
4,411,222	A	10/1983	Wolfson	
4,413,358	A *	11/1983	Jimenez	2/321
5,002,140	A	3/1991	Neumuller	
5,081,719	A *	1/1992	Donnelly	2/311
6,167,572	B1	1/2001	Naumovitz	
D457,688	S *	5/2002	Cordero	D29/100
D500,393	S *	12/2004	Beacham et al.	D29/100
6,868,584	B2	3/2005	Trottier	
6,896,279	B2	5/2005	Galvagno	
D515,245	S *	2/2006	Wartick	D29/100
D519,715	S *	5/2006	Curran	D2/639
7,114,196	B1 *	10/2006	Cicio	2/338
7,137,640	B1	11/2006	Rice et al.	

7,258,192	B2 *	8/2007	Davis et al.	180/312
7,506,714	B2 *	3/2009	Davis et al.	180/89.1
2008/0110290	A1 *	5/2008	Buettner	74/551.8

* cited by examiner

Primary Examiner—Philip S Hyder

Assistant Examiner—Linda G. Brooks

(74) *Attorney, Agent, or Firm*—KB Patents; Luca D'Ottone

(57) **CLAIM**

The ornamental design for a handle-grip accessory for motorcycle passenger, as shown and described.

DESCRIPTION

FIG. 1 is perspective front view of the handle-grip accessory for motorcycle passenger of the present invention.

FIG. 2 is a perspective rear view of the handle-grip accessory for motorcycle passenger of the present invention.

FIG. 3 is a front perspective view of the handle-grip accessory for motorcycle passenger of the present invention.

FIG. 4 is a right side view of the handle-grip accessory for motorcycle passenger of the present invention.

FIG. 5 is a left side view of the handle-grip accessory for motorcycle passenger of the present invention.

FIG. 6 is a top perspective view of the handle-grip accessory for motorcycle passenger of the present invention.

FIG. 7 is a back perspective view of the handle-grip accessory for motorcycle passenger of the present invention; and,

FIG. 8 is a rear perspective view of the handle-grip accessory for motorcycle passenger of the present invention.

1 Claim, 8 Drawing Sheets

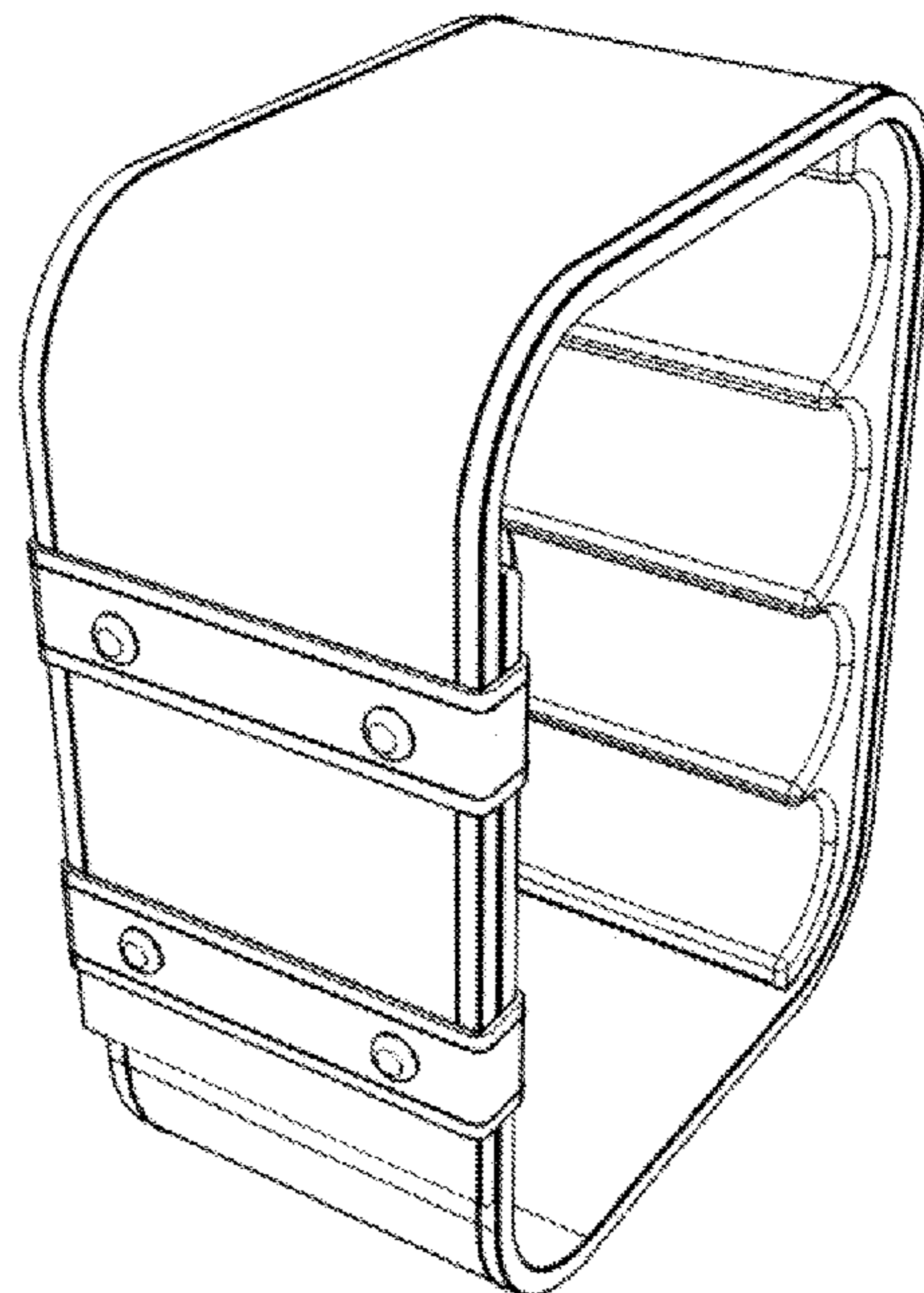
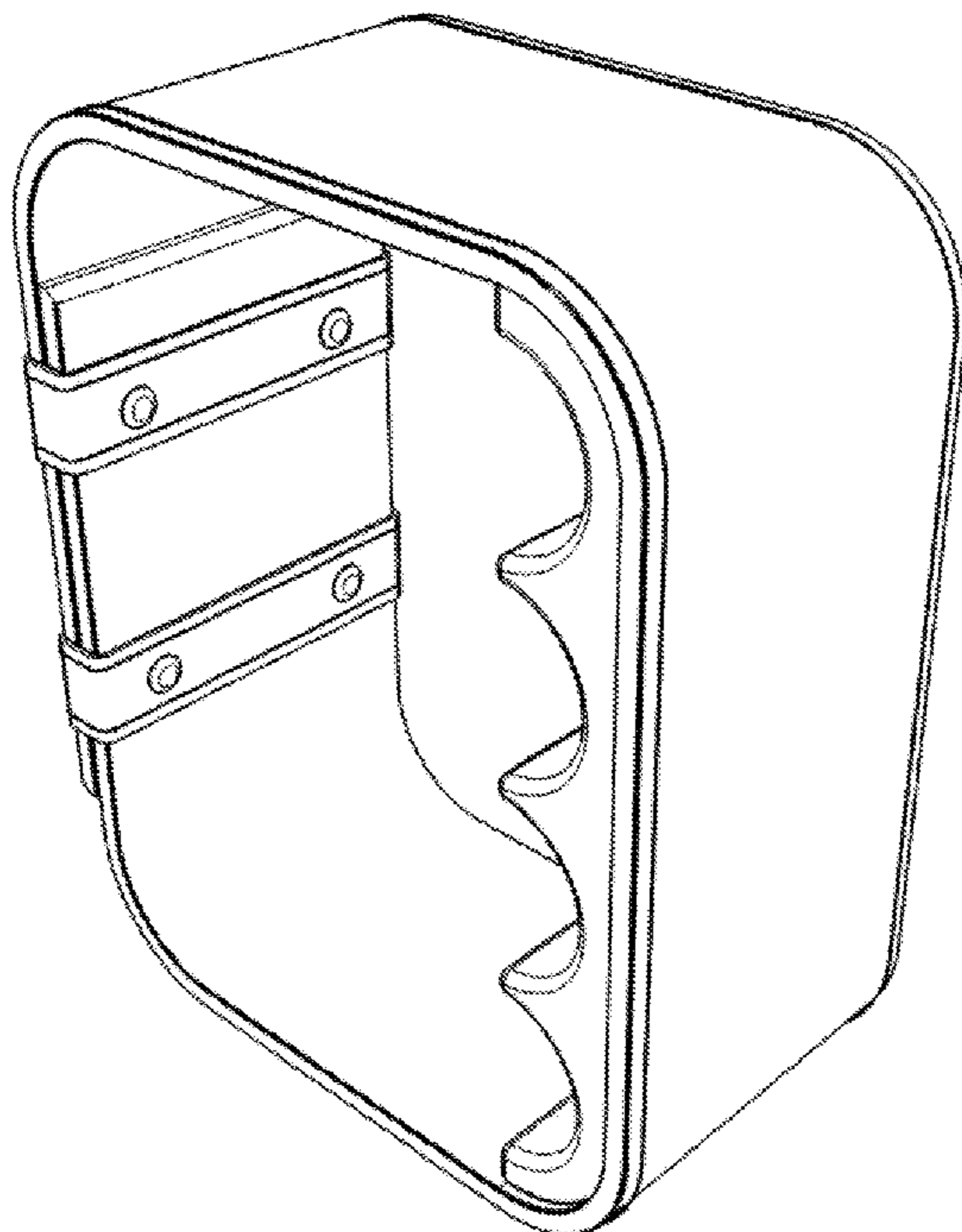

FIG. 1

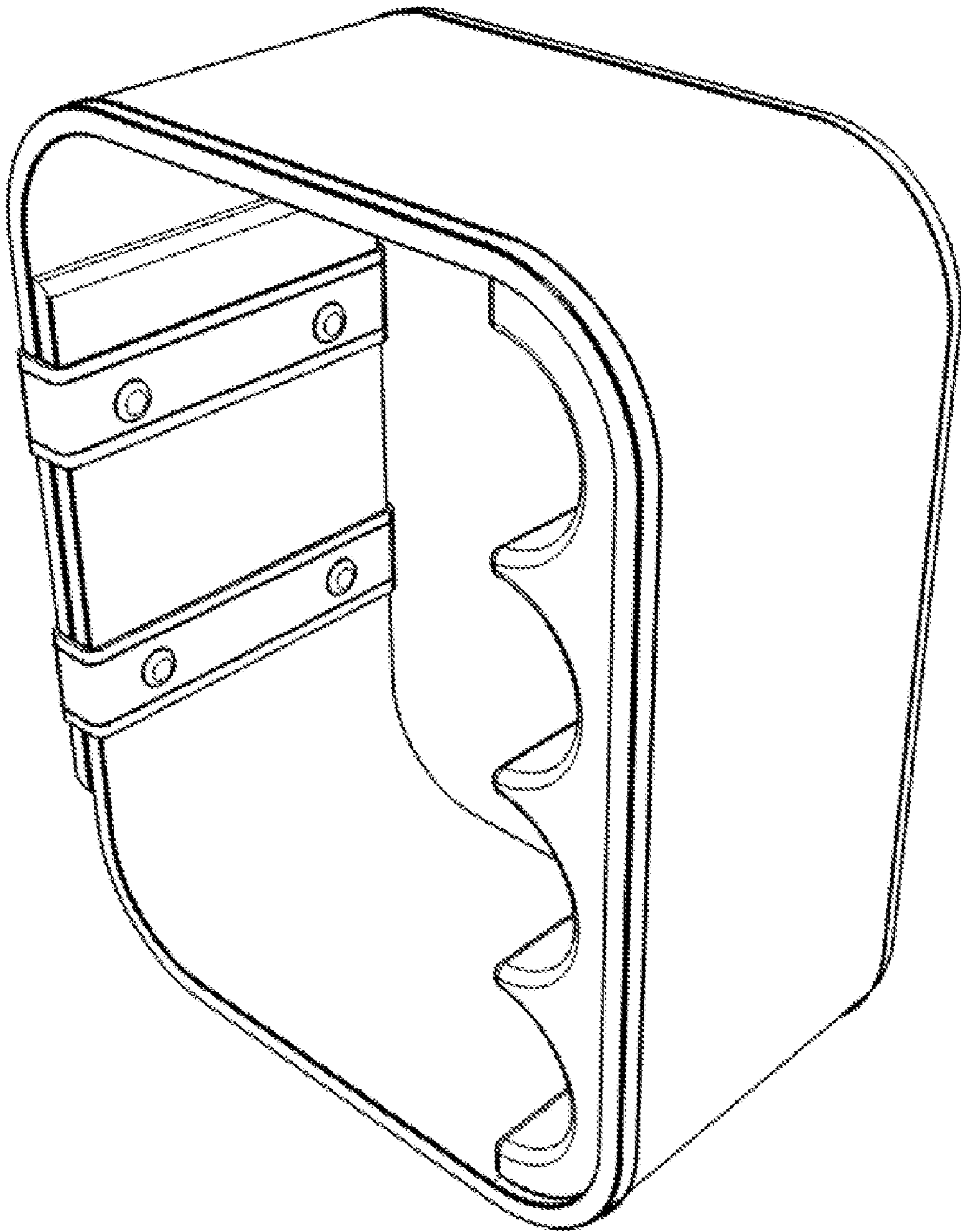

FIG. 2

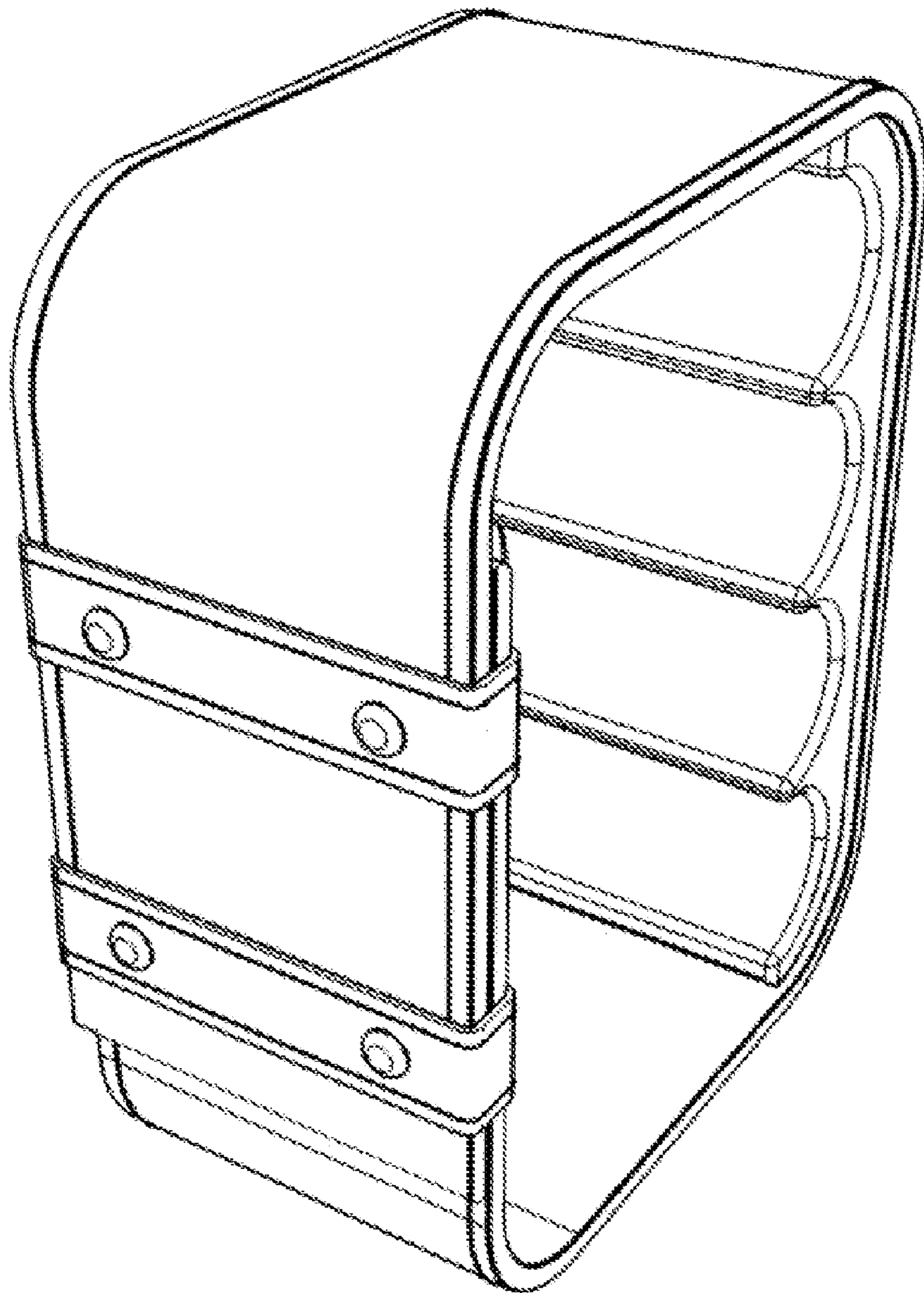

FIG. 3

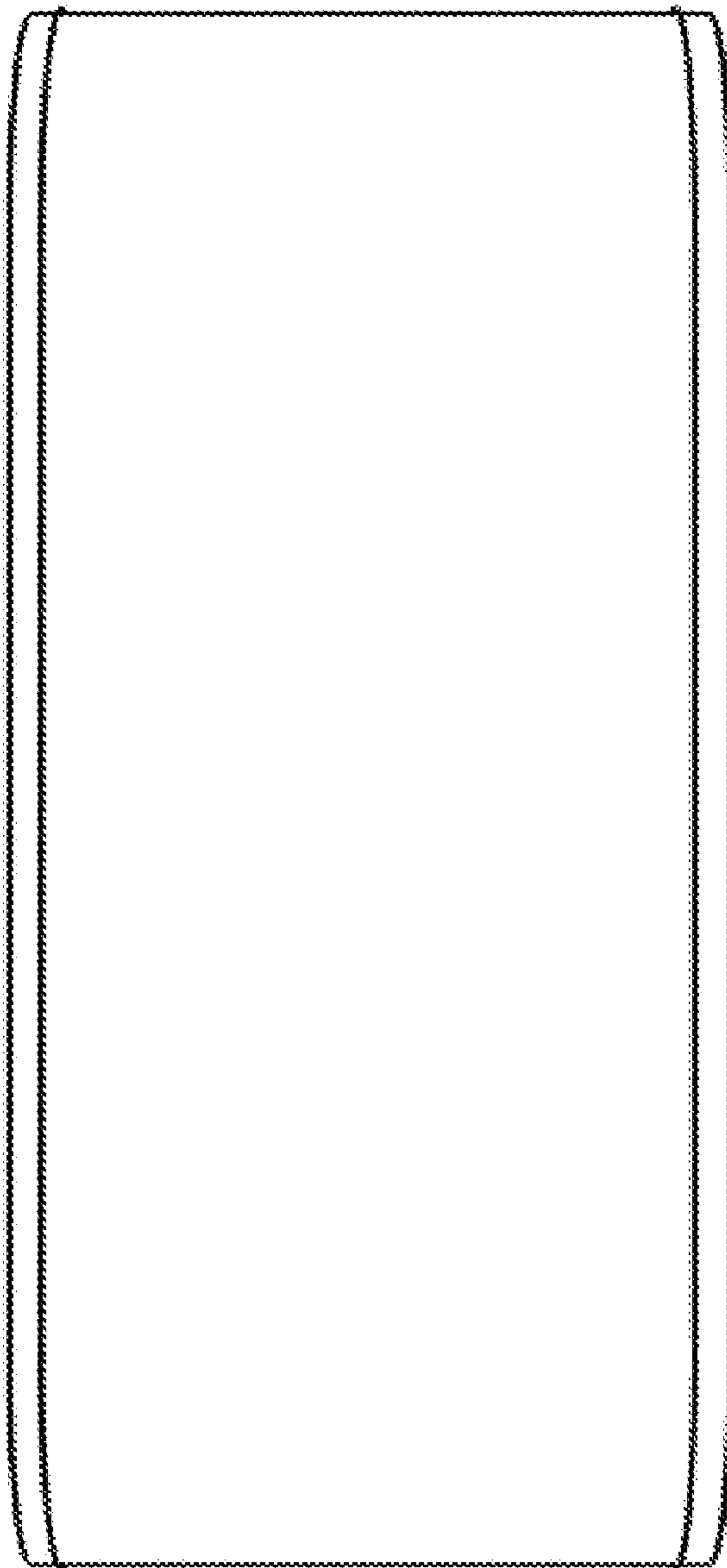

FIG. 4

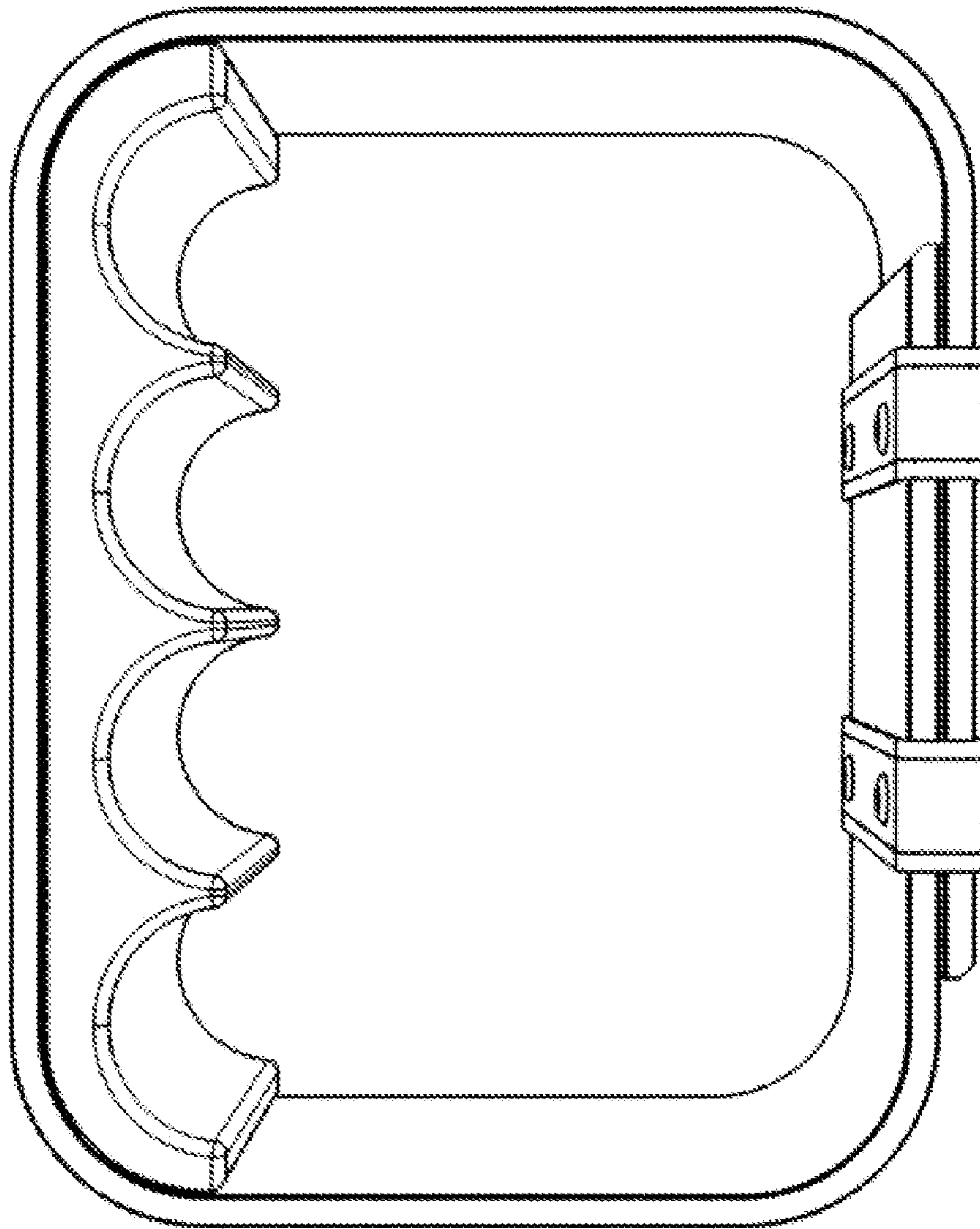

FIG. 5

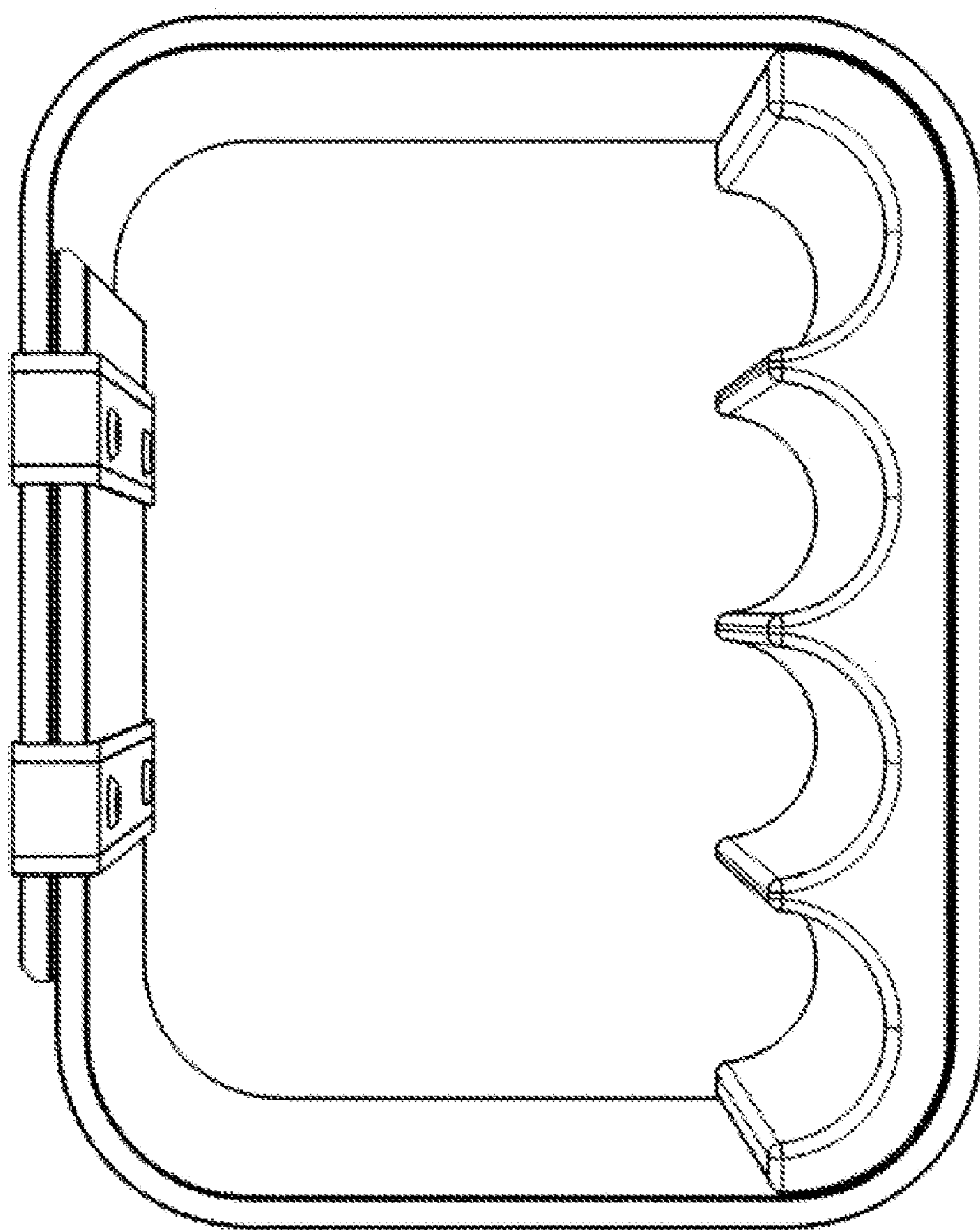

FIG. 6

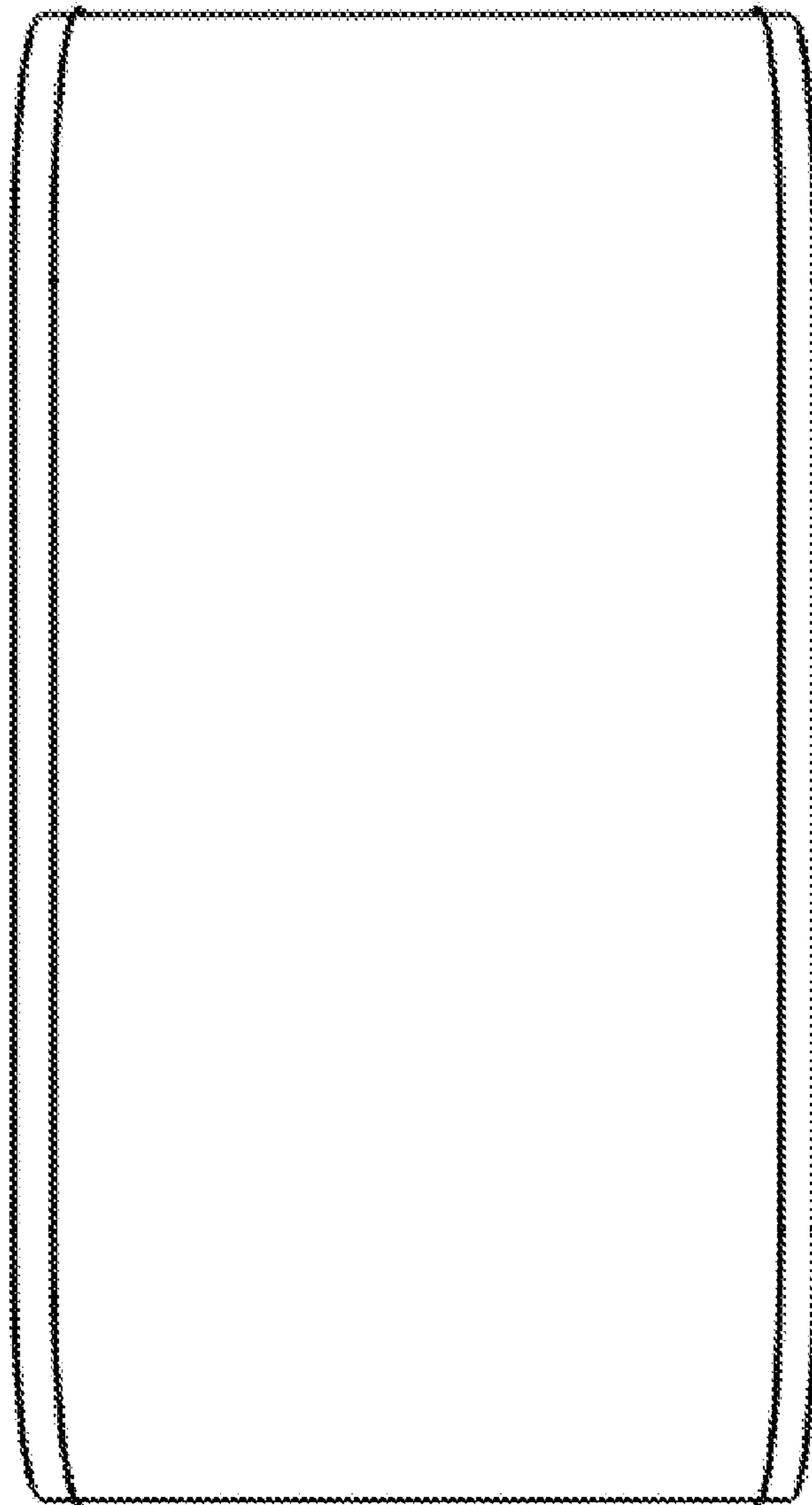

FIG. 7

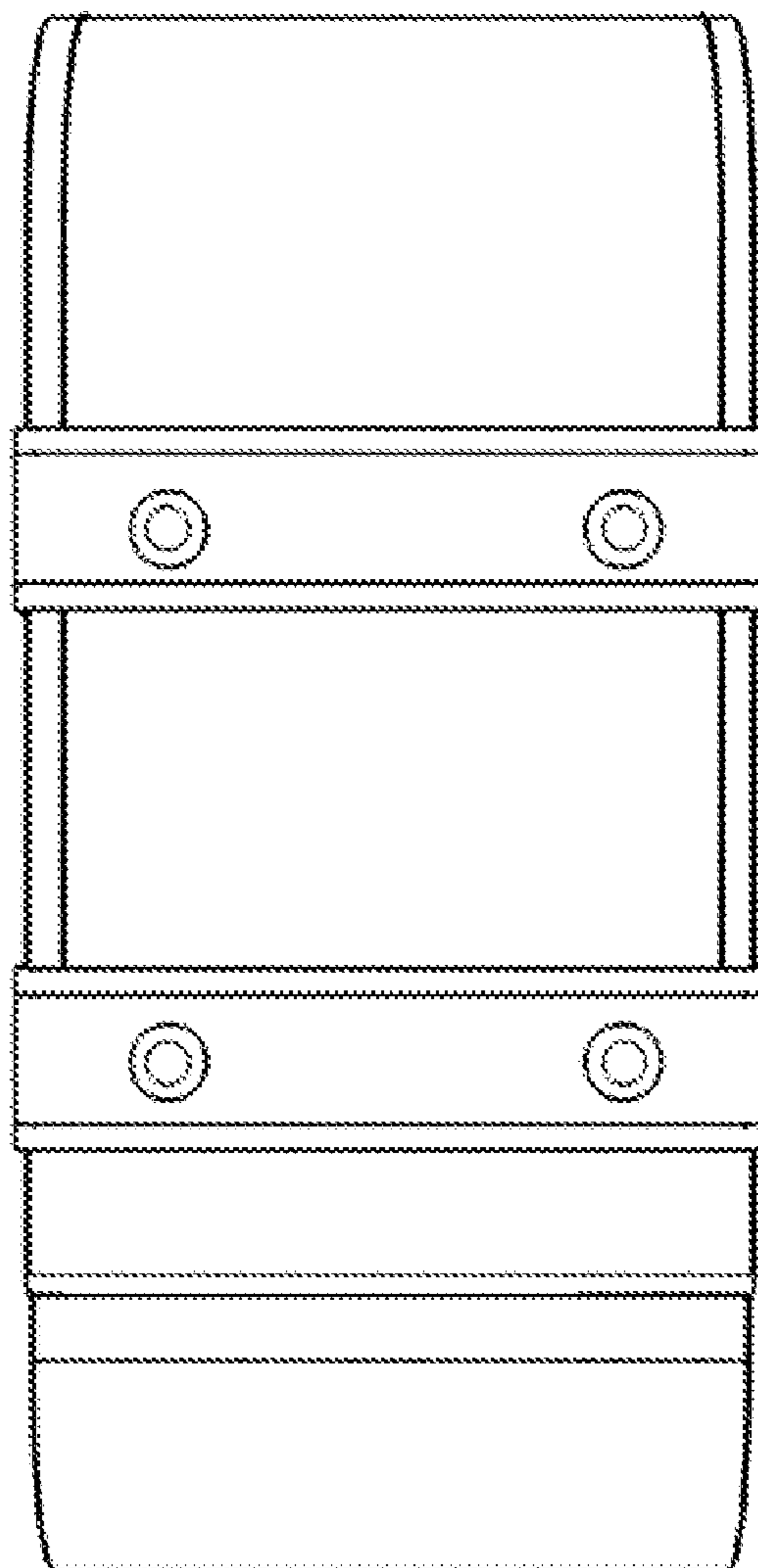

FIG. 8

