



US00D614879S

(12) **United States Design Patent**  
**Higashida et al.**

(10) **Patent No.:** **US D614,879 S**  
(45) **Date of Patent:** **\*\* May 4, 2010**

(54) **VEHICLE SEAT**

(75) Inventors: **Dai Higashida**, Palos Verdes Estates, CA (US); **Kuo-Chang Chen**, Los Alamitos, CA (US)

(73) Assignee: **Honda Motor Co., Ltd.**, Tokyo (JP)

(\*\*) Term: **14 Years**

(21) Appl. No.: **29/344,006**

(22) Filed: **Sep. 22, 2009**

**Related U.S. Application Data**

(63) Continuation of application No. 29/333,734, filed on Mar. 13, 2009, now abandoned, and a continuation of application No. 29/335,040, filed on Apr. 7, 2009.

(51) **LOC (9) Cl.** ..... **06-01**

(52) **U.S. Cl.** ..... **D6/356**

(58) **Field of Classification Search** ..... D6/334-336, D6/356, 367, 368, 374, 375, 381, 500-502; 297/232, 238, 353, 344.1, 354.1, 391, 396, 297/452.21, 452.24, 452.25, 452.26, 452.29, 297/452.34, 452.35

See application file for complete search history.

(56) **References Cited**

**U.S. PATENT DOCUMENTS**

5,704,685 A \* 1/1998 Handa et al. .... 297/238  
5,829,833 A \* 11/1998 Handa et al. .... 297/238

D536,188 S \* 2/2007 Moburg ..... D6/356  
D542,041 S \* 5/2007 Moburg ..... D6/356  
D576,811 S \* 9/2008 Wyszogrod et al. .... D6/356  
D578,315 S \* 10/2008 Wyszogrod et al. .... D6/356  
D590,611 S \* 4/2009 Higashida ..... D6/356  
D590,612 S \* 4/2009 Zhang et al. .... D6/356  
2006/0071529 A1 \* 4/2006 Yetukuri et al. .... 297/396

\* cited by examiner

*Primary Examiner*—Mimosa De

(74) *Attorney, Agent, or Firm*—Plumsea Law Group, LLC; Mark E. Duell

(57) **CLAIM**

The ornamental design for a vehicle seat, as shown and described.

**DESCRIPTION**

FIG. 1 is a perspective view of a vehicle seat showing our new design;

FIG. 2 is a front elevational view thereof;

FIG. 3 is a side view thereof; and,

FIG. 4 is a top plan view thereof.

The broken line showings of the remainder of the vehicle seat form no part of the claimed design.

**1 Claim, 4 Drawing Sheets**

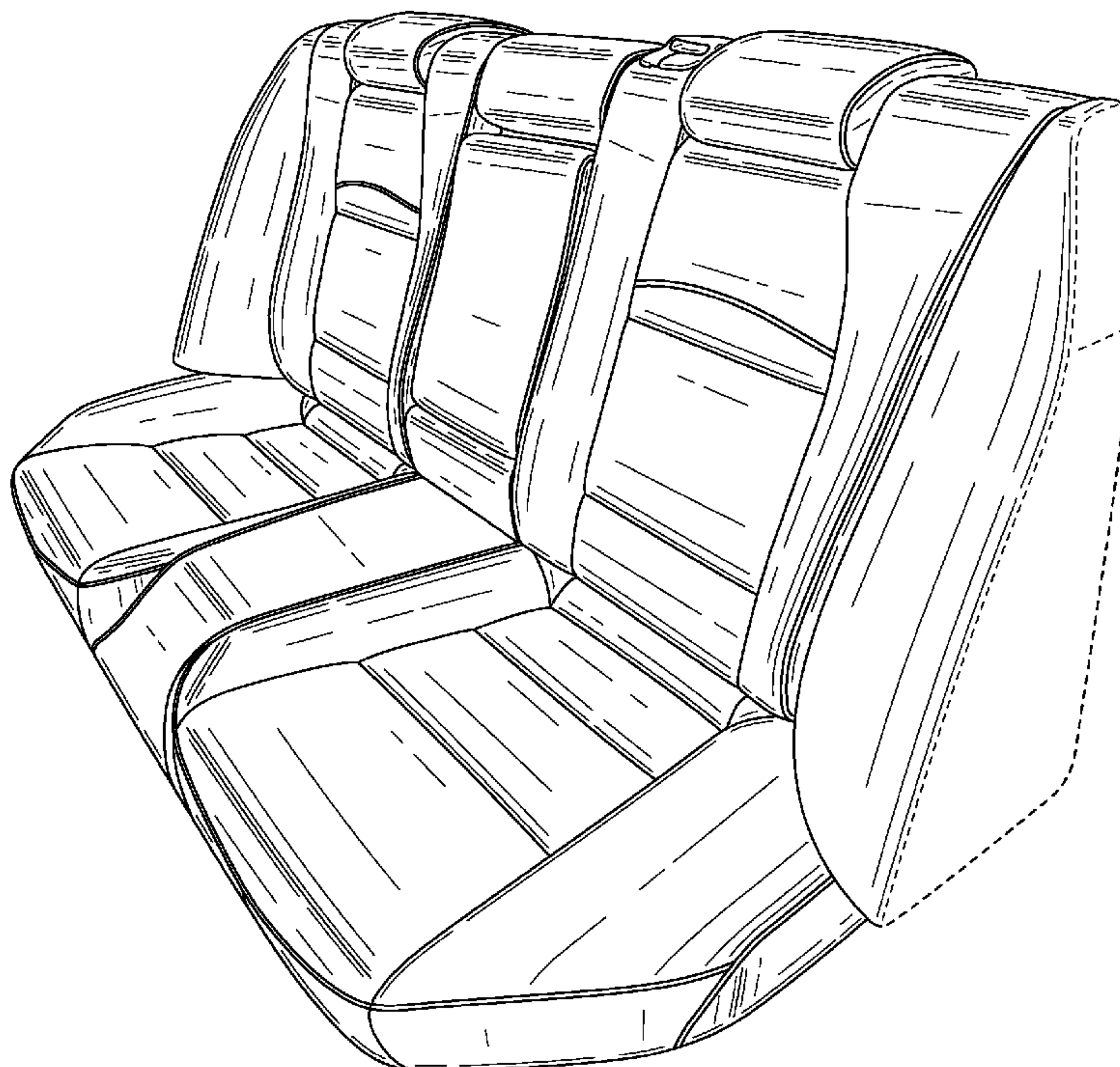

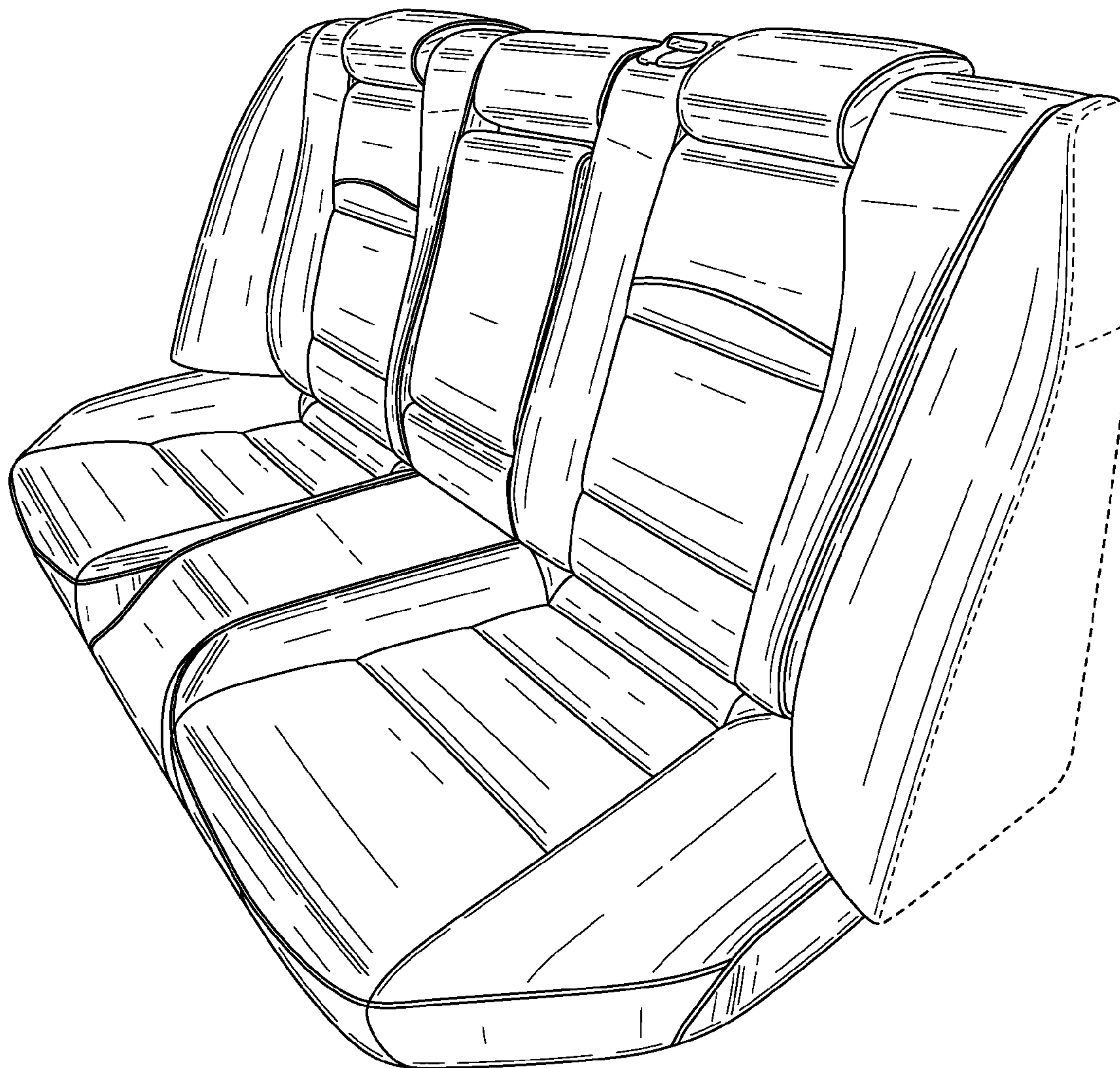

FIG. 1

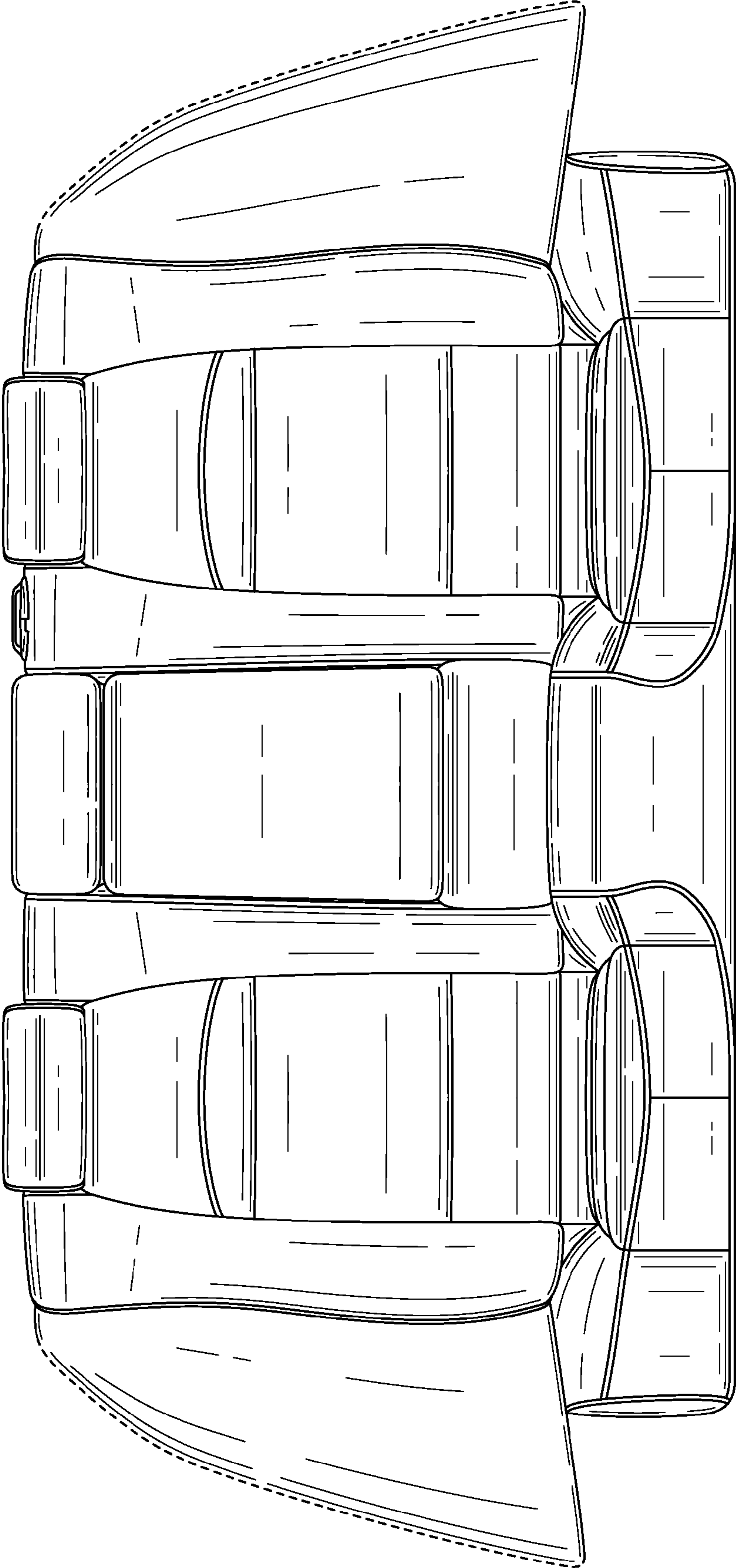

FIG. 2

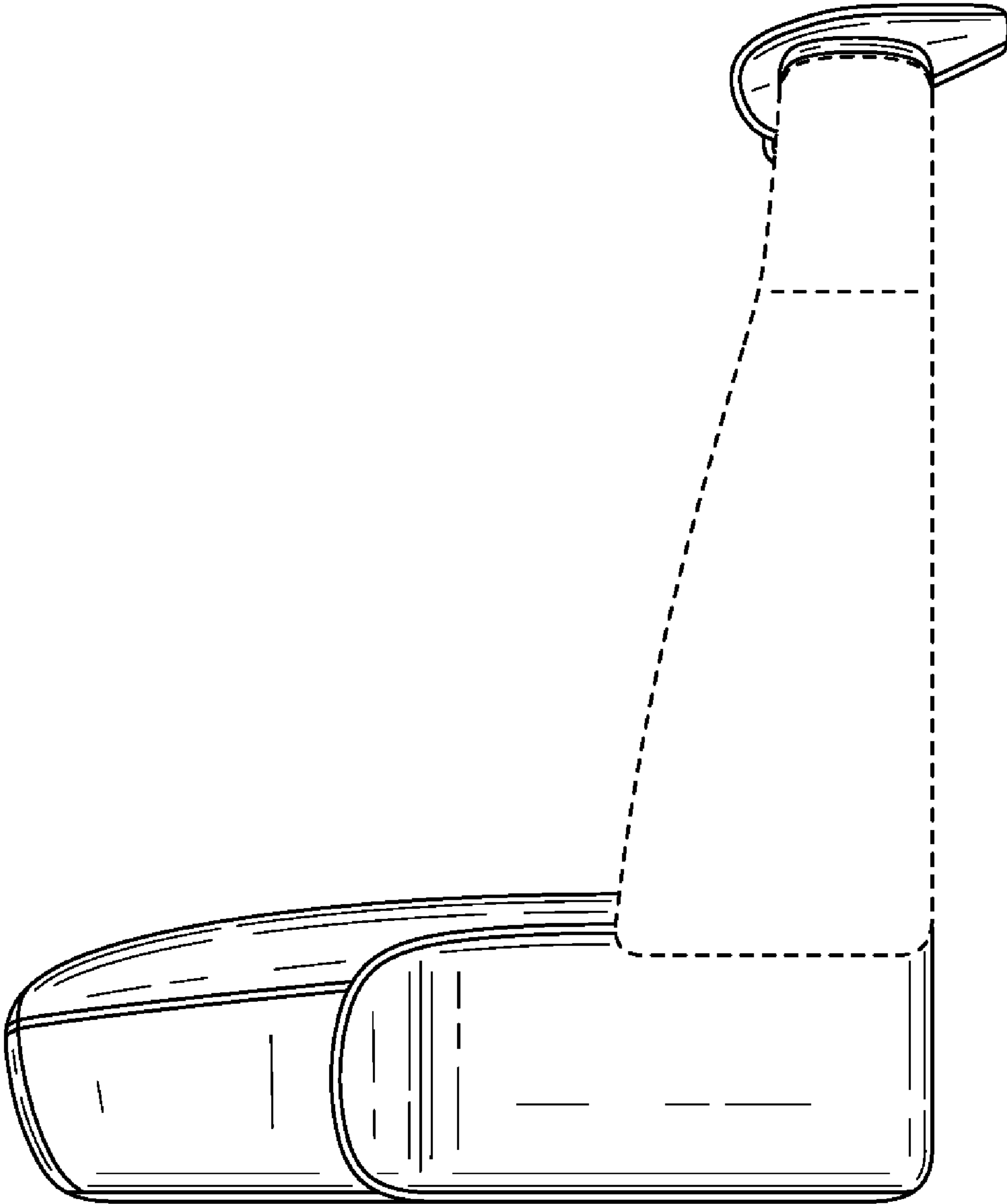

FIG. 3



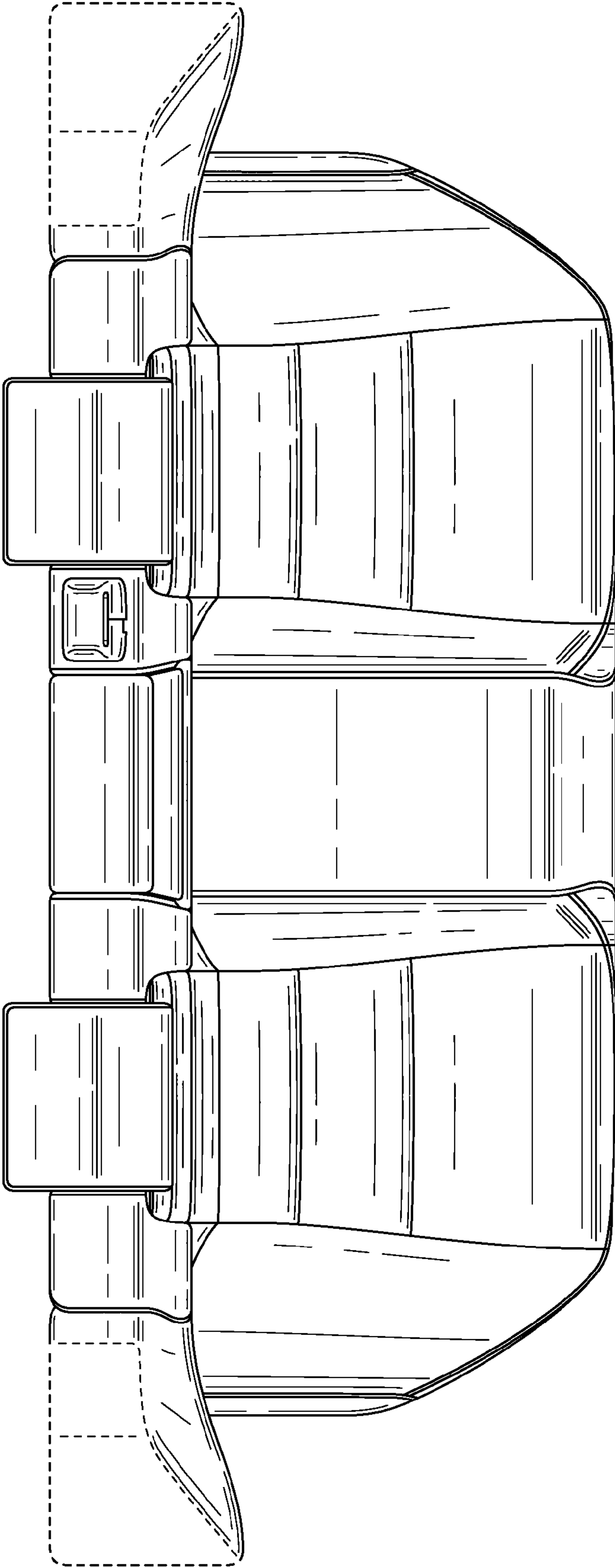

FIG. 4