



US00D614547S

(12) **United States Design Patent**  
**Schell et al.**

(10) **Patent No.:** **US D614,547 S**

(45) **Date of Patent:** **\*\* Apr. 27, 2010**

(54) **COMBINED VEHICLE GRILLE AND BUMPER**

(75) Inventors: **Damon Arthur Schell**, Redondo Beach, CA (US); **Hiroshi Kannon**, Saitama (JP)

(73) Assignee: **Honda Motor Co., Ltd.**, Tokyo (JP)

(\*\*) Term: **14 Years**

(21) Appl. No.: **29/335,038**

(22) Filed: **Apr. 7, 2009**

**Related U.S. Application Data**

(63) Continuation of application No. 29/333,734, filed on Mar. 13, 2009, now abandoned, and a continuation of application No. 29/333,759, filed on Mar. 13, 2009.

(51) **LOC (9) Cl.** ..... **12-16**

(52) **U.S. Cl.** ..... **D12/169; D12/163**

(58) **Field of Classification Search** ..... D12/169, D12/196, 171, 163, 216, 90-92, 86; 293/102, 293/113, 115, 117, 120; 296/180.1, 180.2, 296/193.11; 180/68.1, 68.6  
See application file for complete search history.

(56) **References Cited**

**U.S. PATENT DOCUMENTS**

D515,994 S \* 2/2006 Moruzzi ..... D12/169  
D555,040 S \* 11/2007 Davidson ..... D12/92

D555,041 S \* 11/2007 Davidson ..... D12/92  
D566,016 S \* 4/2008 Pfeiffer ..... D12/169  
D567,724 S \* 4/2008 Irie et al. .... D12/169  
D576,527 S \* 9/2008 Nakajima et al. .... D12/169  
D579,389 S \* 10/2008 Miyazaki ..... D12/169  
D583,284 S \* 12/2008 Schell ..... D12/163  
D586,263 S \* 2/2009 Osborne et al. .... D12/92  
D589,415 S \* 3/2009 Osborne et al. .... D12/169  
D599,706 S \* 9/2009 Tanaka et al. .... D12/92  
D602,399 S \* 10/2009 Sakae et al. .... D12/91

\* cited by examiner

*Primary Examiner*—Melody N Brown

(74) *Attorney, Agent, or Firm*—Plumsea Law Group, LLC; Mark E. Duell

(57) **CLAIM**

The ornamental design for a combined vehicle grille and bumper, as shown and described.

**DESCRIPTION**

FIG. 1 is a perspective view of a combined vehicle grille and bumper, showing our new design;

FIG. 2 is a side elevational view of one side thereof;

FIG. 3 is a side elevational view of the opposite side thereof; and,

FIG. 4 is a front elevational view thereof.

The broken line showings of the remainder of the vehicle form no part of the claimed design.

**1 Claim, 4 Drawing Sheets**

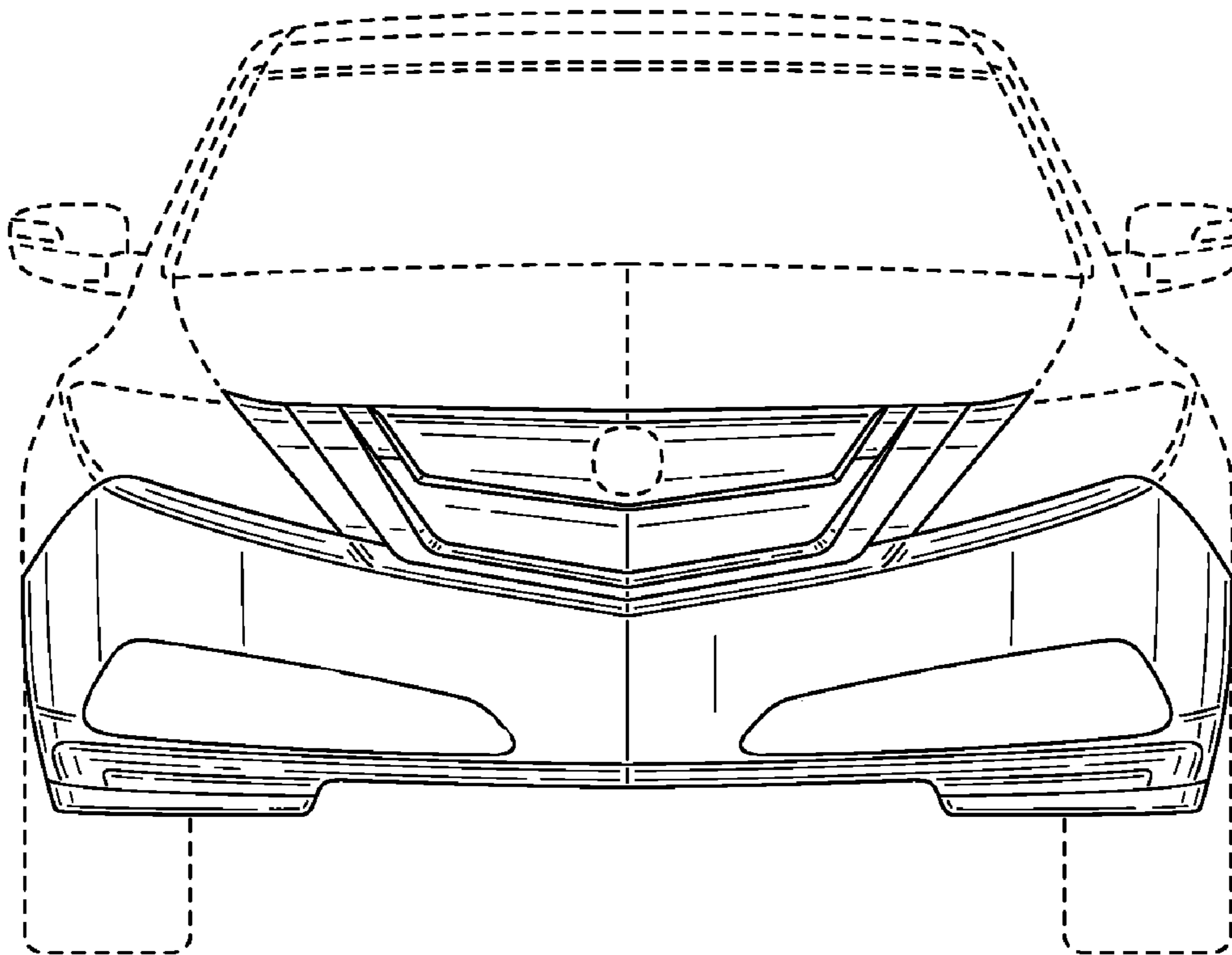

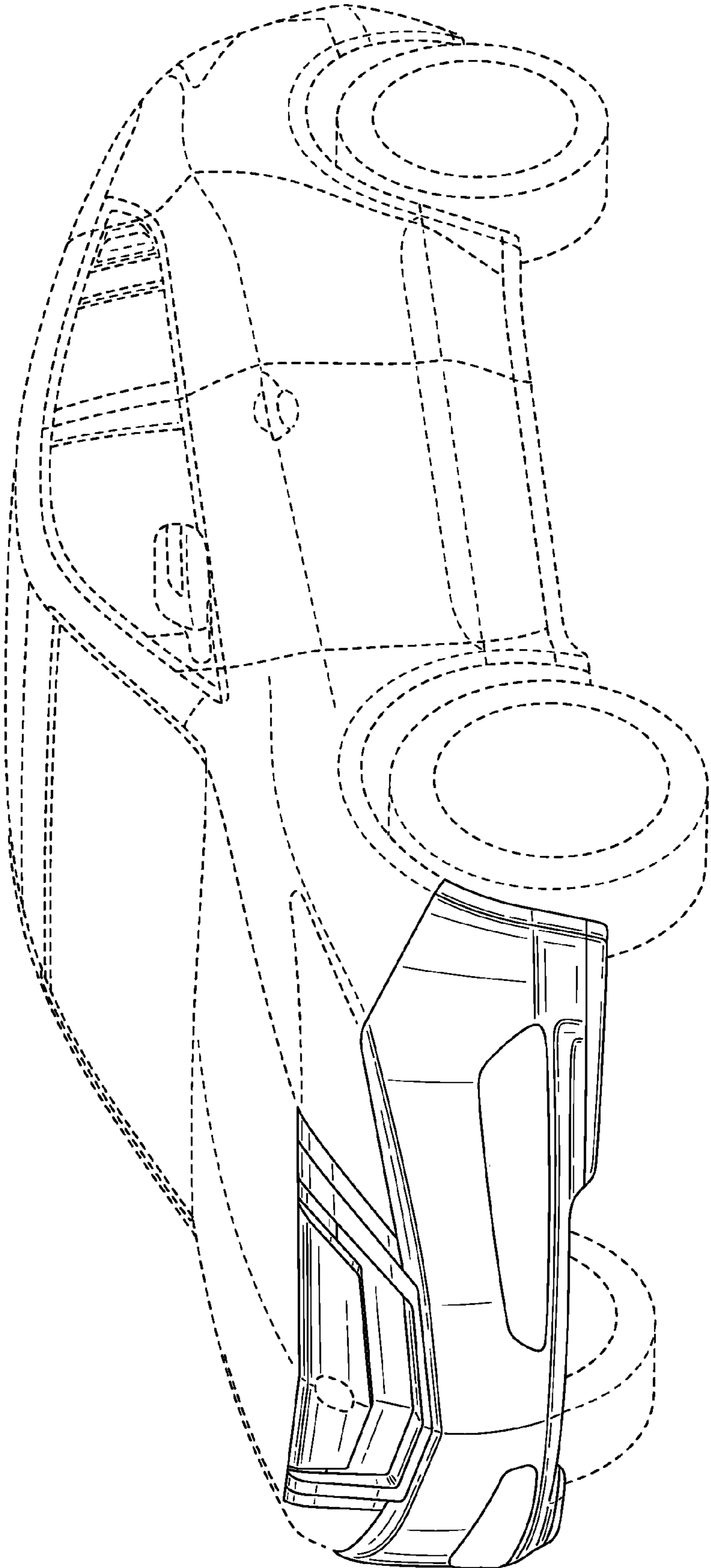

FIG. 1

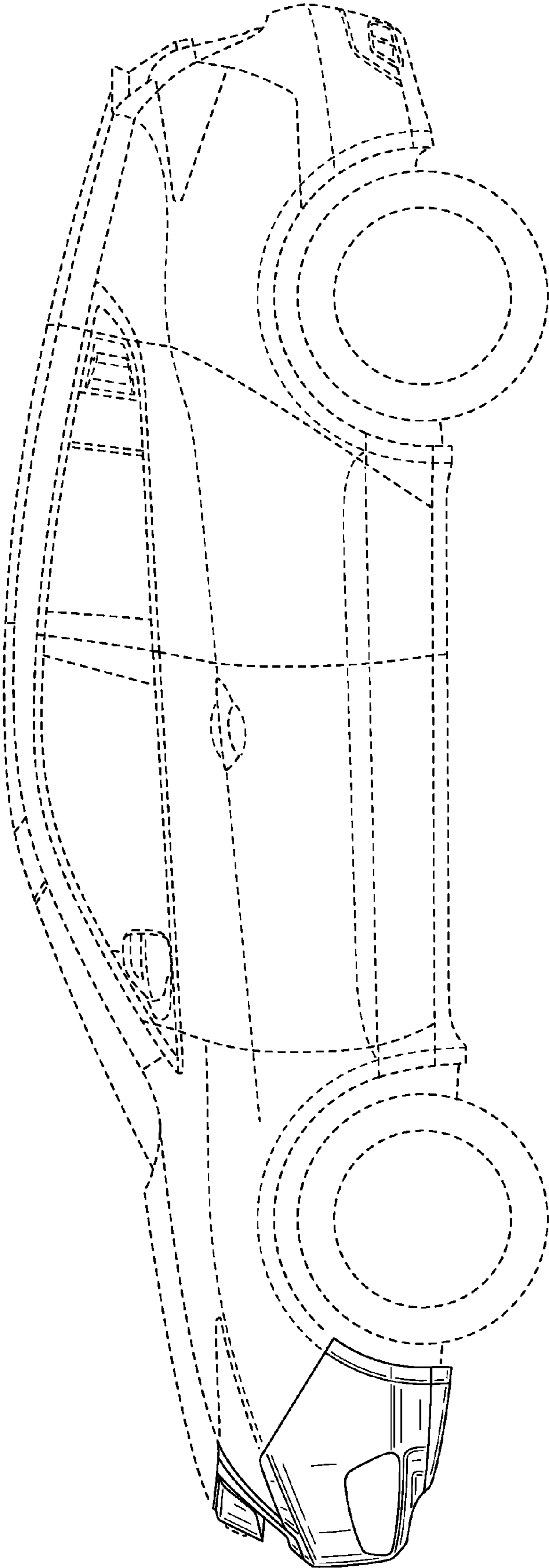

FIG. 2

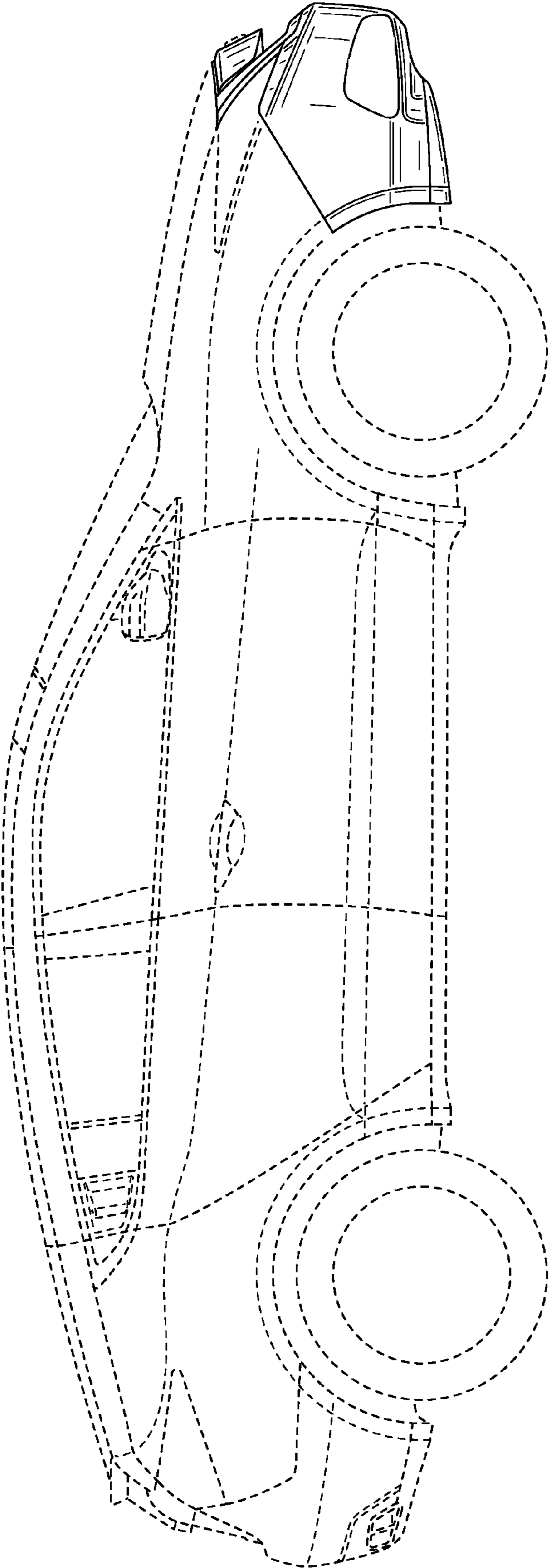

FIG. 3

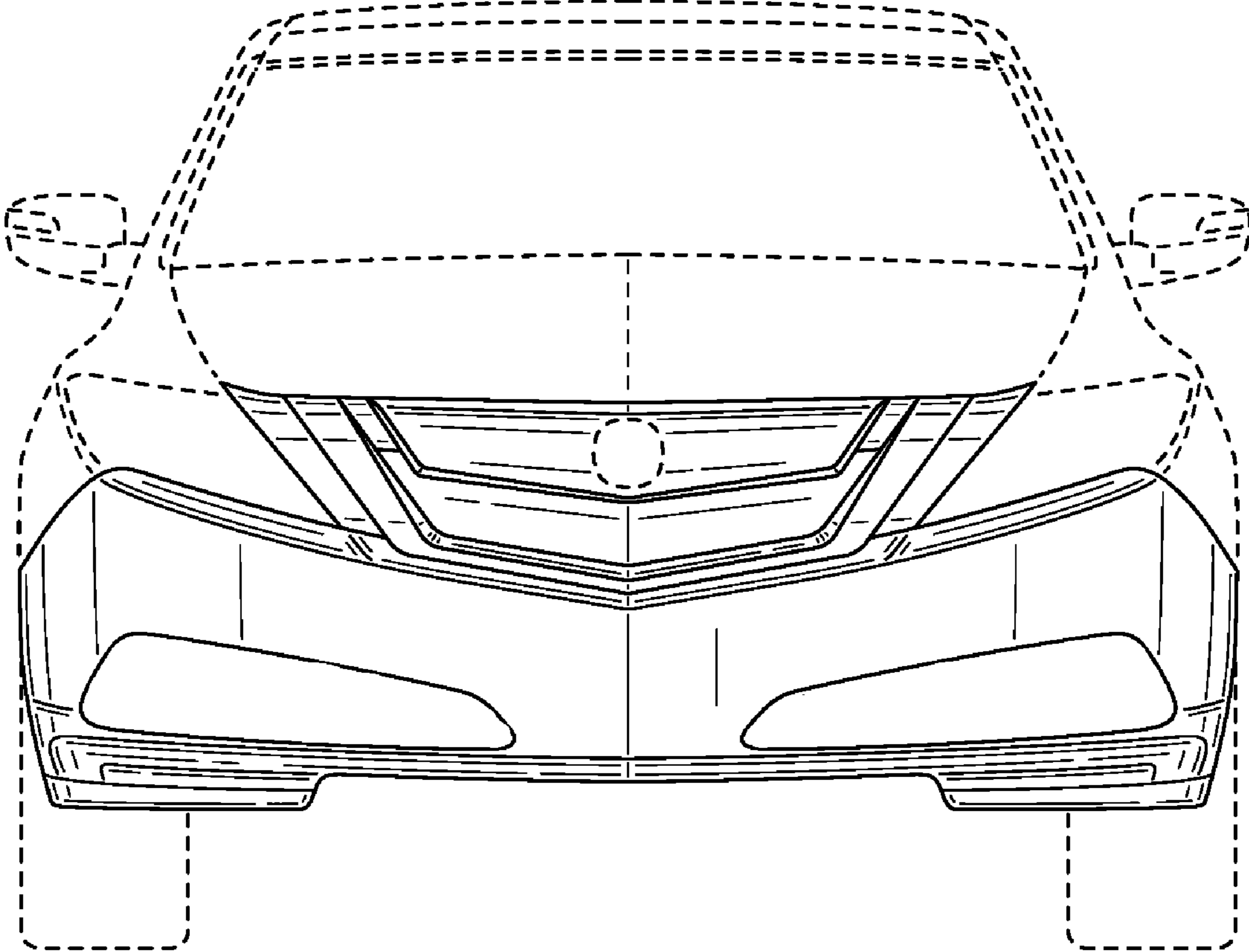

FIG. 4

UNITED STATES PATENT AND TRADEMARK OFFICE  
**CERTIFICATE OF CORRECTION**

PATENT NO. : D614,547 S  
APPLICATION NO. : 29/335038  
DATED : April 27, 2010  
INVENTOR(S) : Damon Arthur Schell et al.

Page 1 of 1

It is certified that error appears in the above-identified patent and that said Letters Patent is hereby corrected as shown below:

On the Title Page, item (74) Inventors:

The second inventor's last name "Kannon" is replaced with --Kannan--

Signed and Sealed this  
Eighth Day of February, 2011

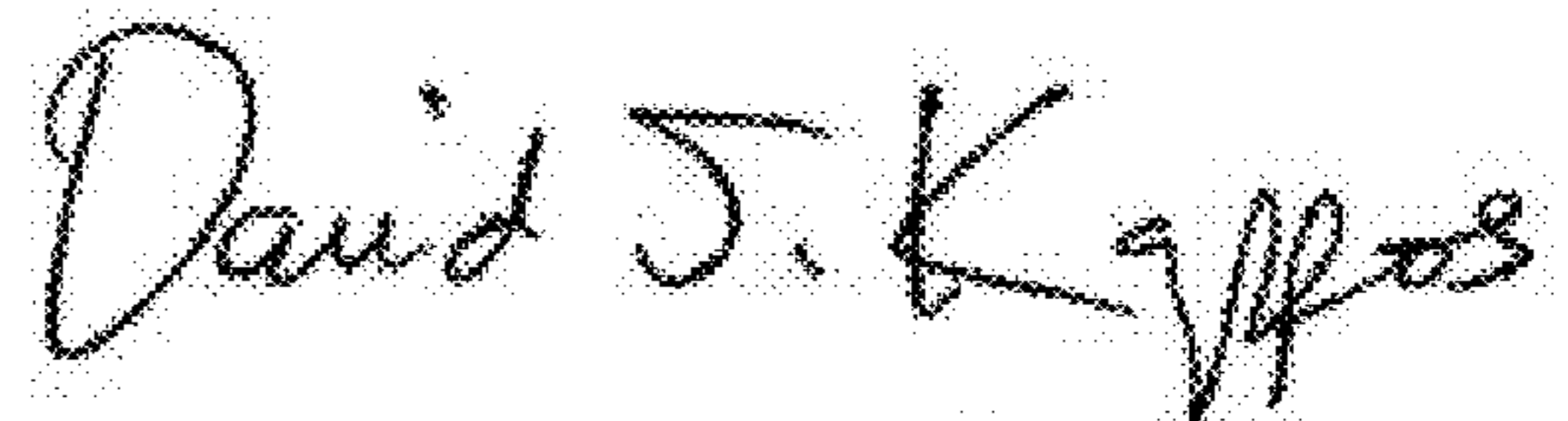
A handwritten signature in black ink that reads "David J. Kappos". The signature is written in a cursive, slightly slanted style.

David J. Kappos  
*Director of the United States Patent and Trademark Office*