



US00D614453S

(12) **United States Design Patent**
Curtin et al.

(10) **Patent No.:** **US D614,453 S**
(45) **Date of Patent:** **** Apr. 27, 2010**

- (54) **COLLAPSIBLE FOOD CARRIER**
- (75) Inventors: **Heather Curtin**, Renton, WA (US);
Christine J. Lee, Seattle, WA (US);
Caroline Park, Seattle, WA (US)
- (73) Assignee: **Progressive International Corporation**,
Kent, WA (US)

- D481,910 S 11/2003 Kim
- D500,227 S 12/2004 Seok
- D508,378 S 8/2005 Bertulis
- D527,227 S 8/2006 Bertulis
- D549,519 S 8/2007 Moon et al.
- D557,601 S 12/2007 Minidis
- 7,472,799 B2 1/2009 Cadiente et al.
- D588,874 S 3/2009 Huang
- D592,049 S 5/2009 Doliwa et al.

(**) Term: **14 Years**

* cited by examiner

(21) Appl. No.: **29/341,442**

Primary Examiner—Terry A Wallace

(22) Filed: **Aug. 5, 2009**

(74) *Attorney, Agent, or Firm*—Black Lowe & Graham,
PLLC

(51) **LOC (9) Cl.** **07-07**

(57) **CLAIM**

(52) **U.S. Cl.** **D7/629**

The ornamental design for a collapsible food carrier, as shown.

(58) **Field of Classification Search** D7/601,
D7/602, 629, 392.1; 206/553, 557, 508,
206/519; 220/6, 666, 667, 780–806

DESCRIPTION

See application file for complete search history.

FIG. 1 is a perspective view of the collapsible food carrier, showing my new design;

(56) **References Cited**

U.S. PATENT DOCUMENTS

- 2,725,087 A 11/1955 Potter
- 3,347,060 A 10/1967 Barkan
- D235,406 S 6/1975 Daenen
- 3,981,401 A * 9/1976 Blanchard 206/508
- 4,157,103 A 6/1979 La Fleur
- 5,377,860 A 1/1995 Littlejohn et al.
- D413,489 S * 9/1999 Miller D7/629

FIG. 2 is a front view of the collapsible food carrier;

FIG. 3 is a top view of the collapsible food carrier;

FIG. 4 is a left side view of the collapsible food carrier;

FIG. 5 is a right side view of the collapsible food carrier; and,

FIG. 6 is a bottom view of the collapsible food carrier.

1 Claim, 4 Drawing Sheets

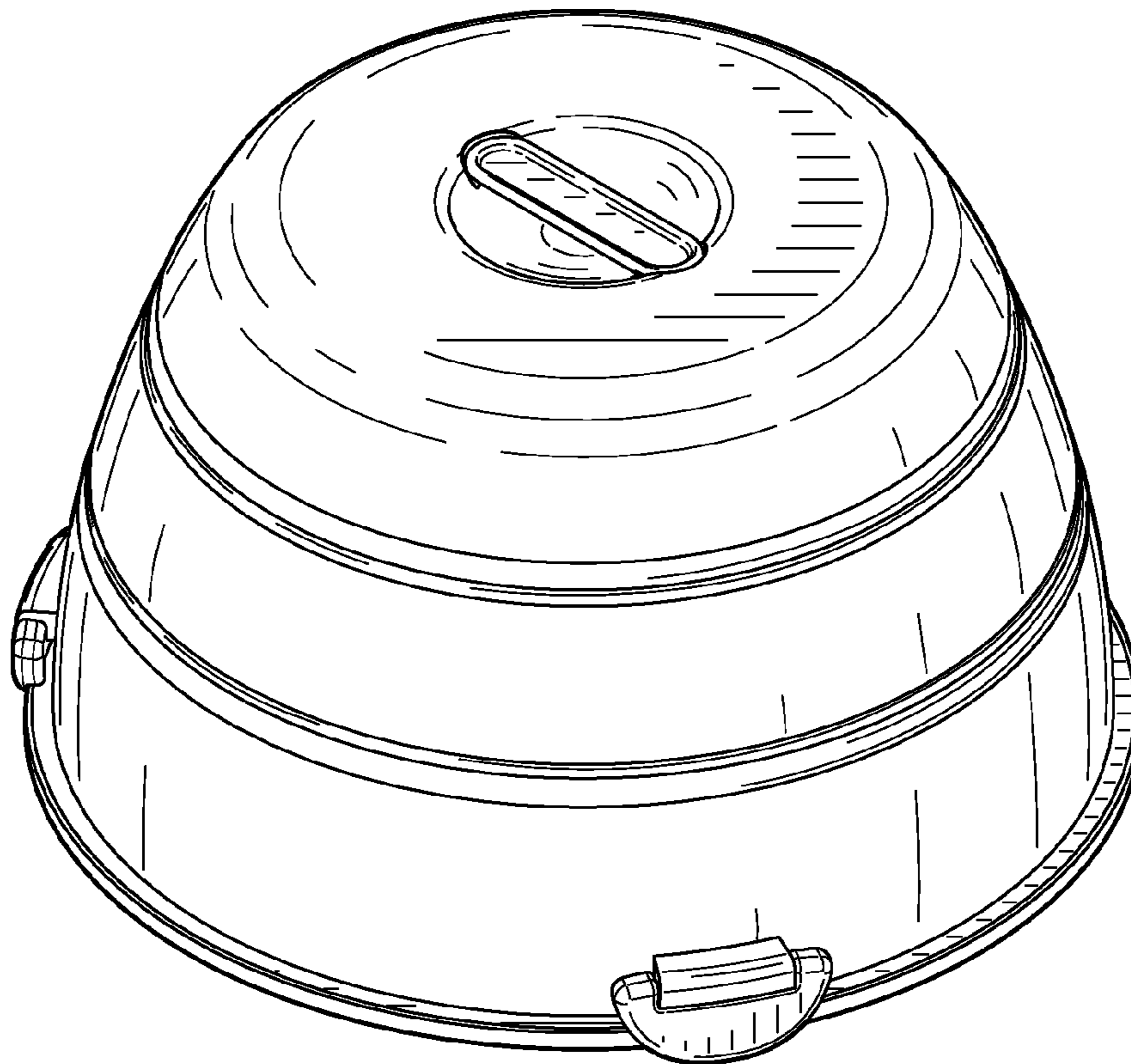

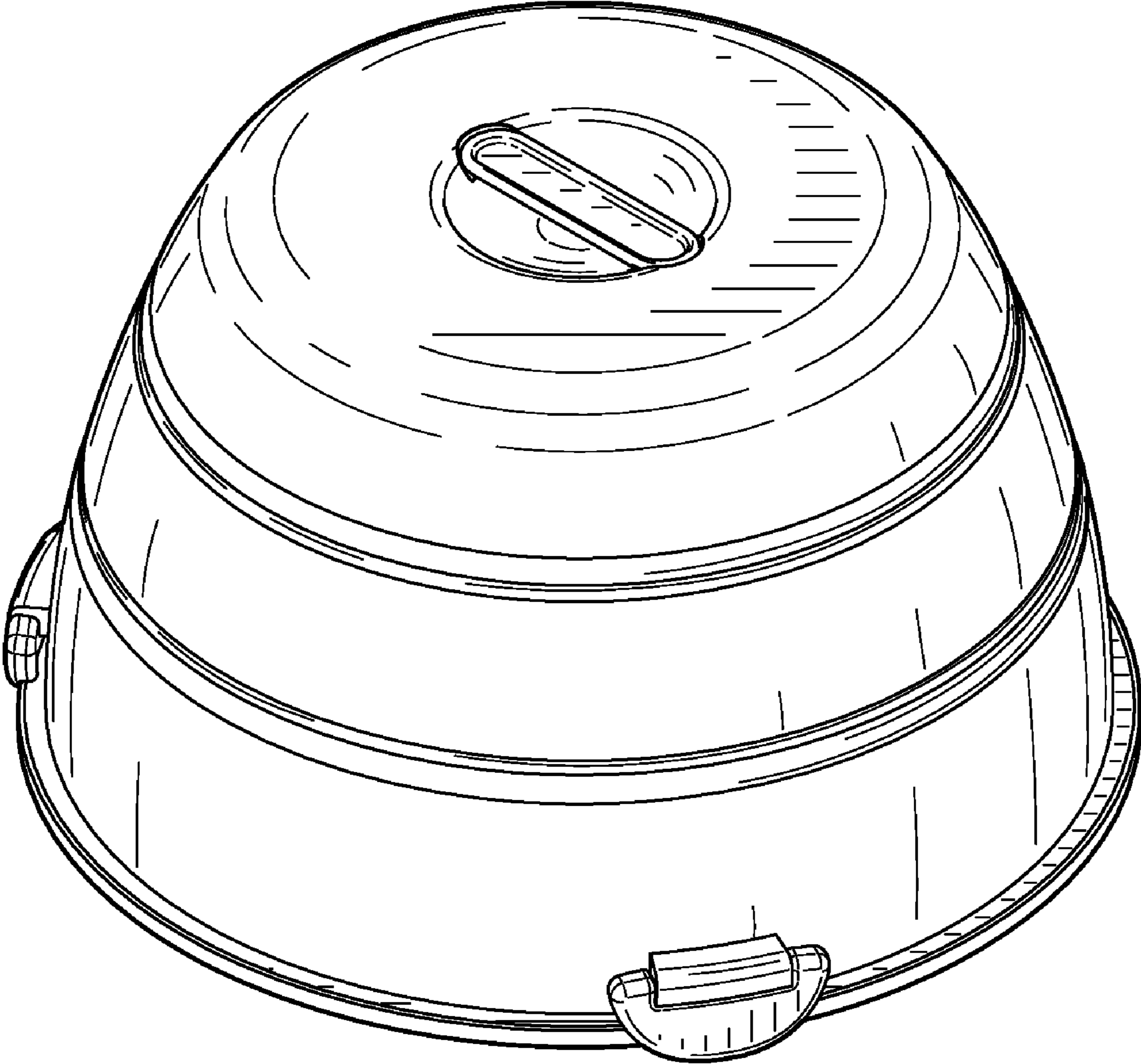

FIG.1

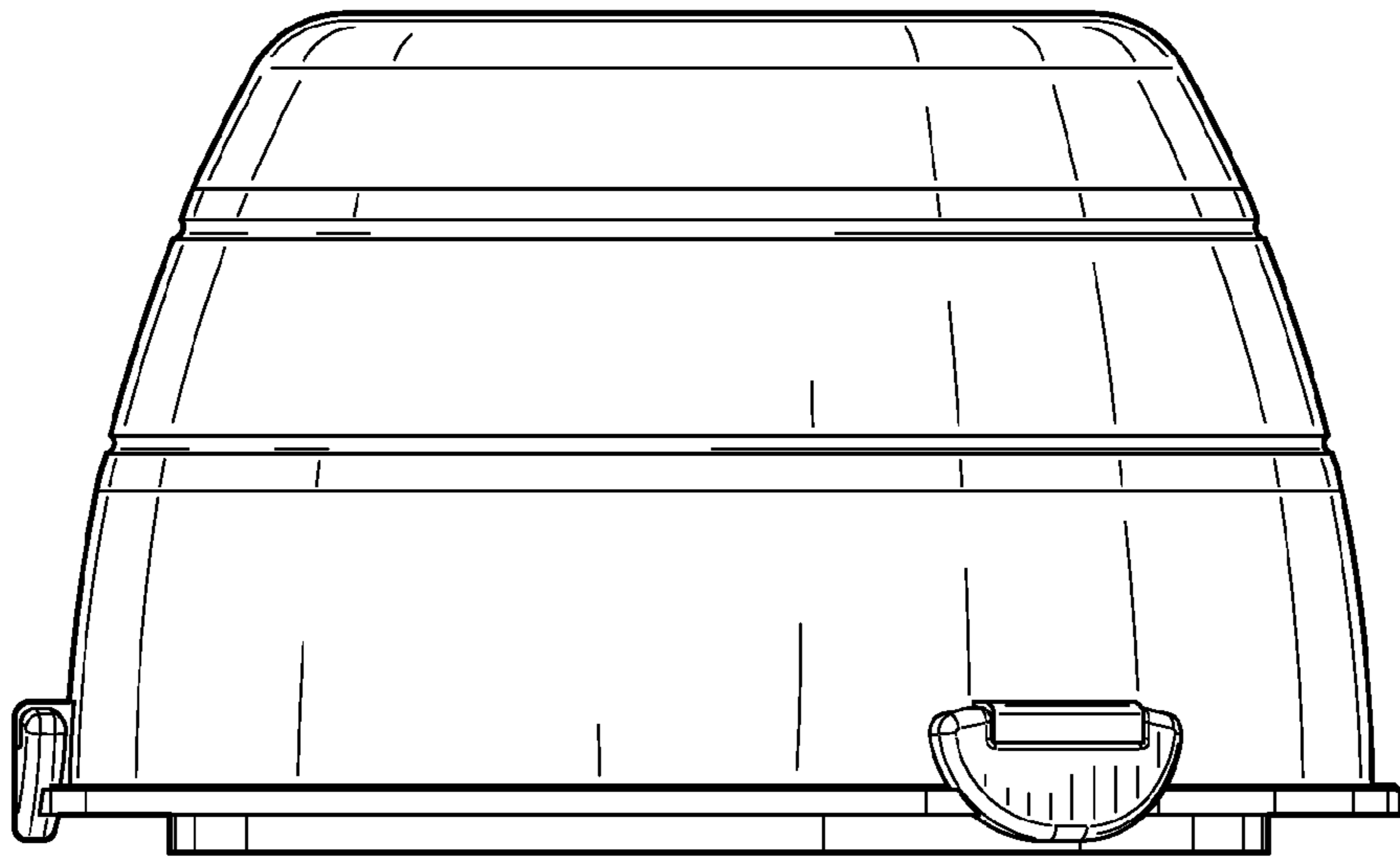

FIG. 2

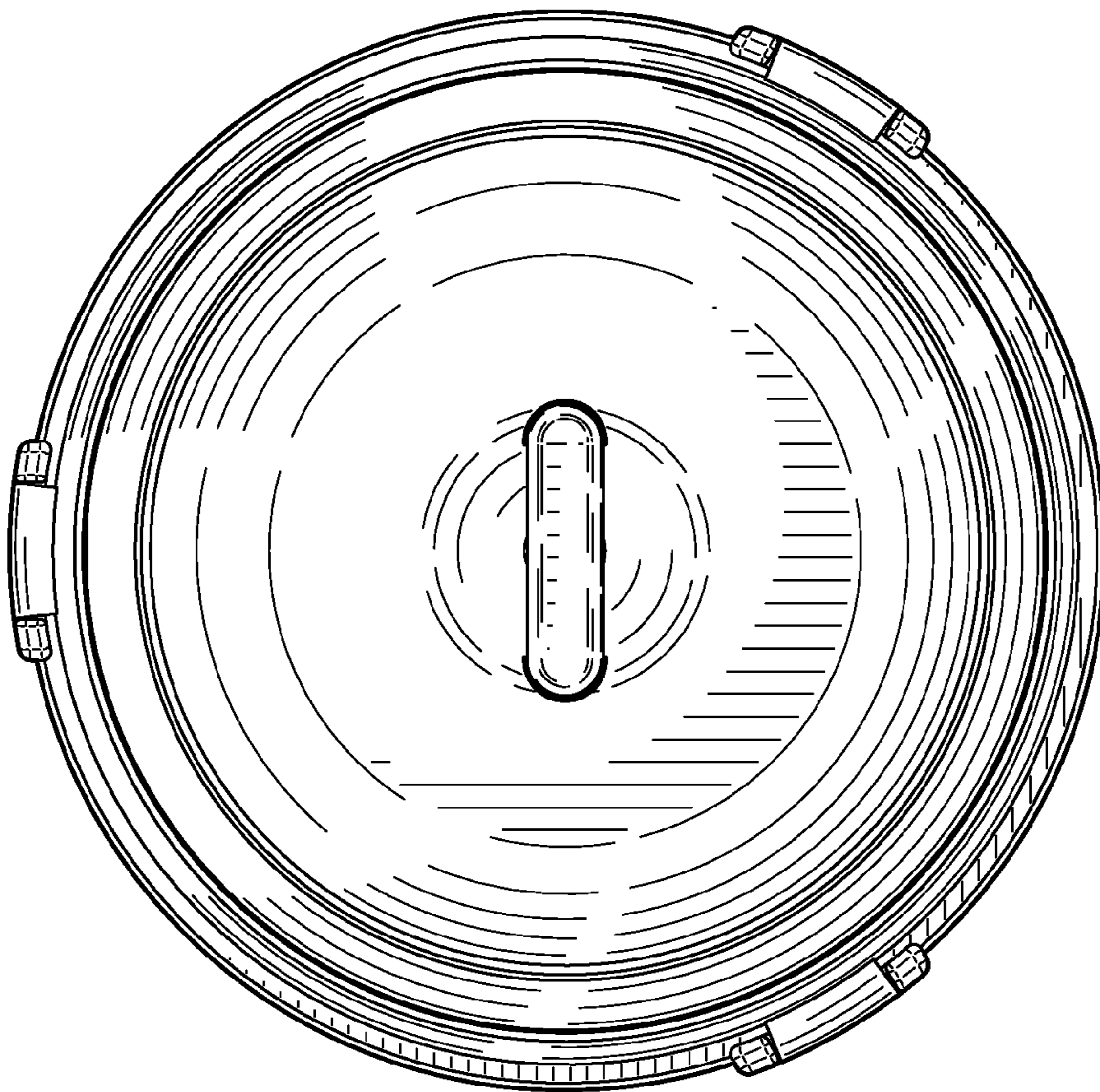

FIG. 3

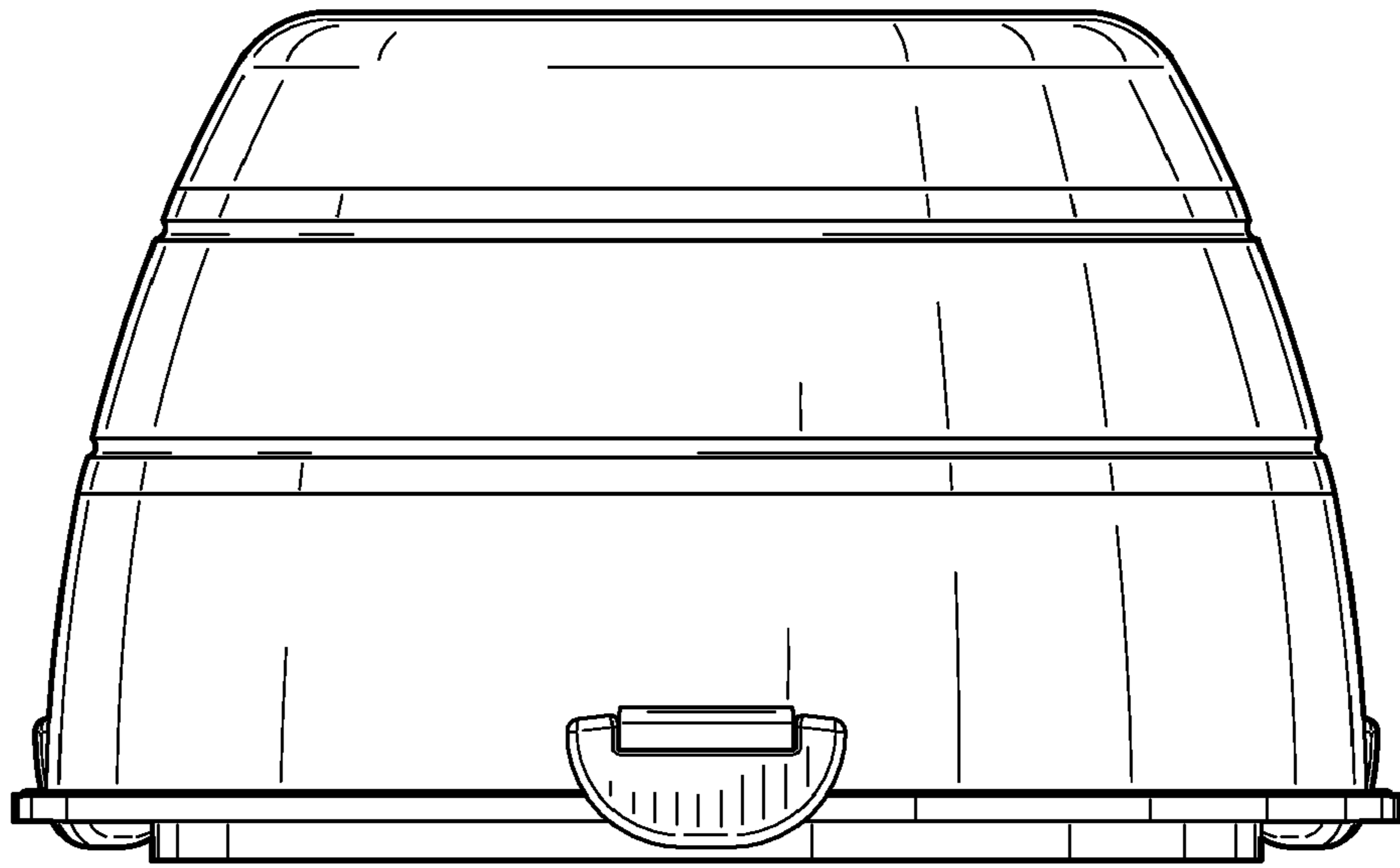

FIG. 4

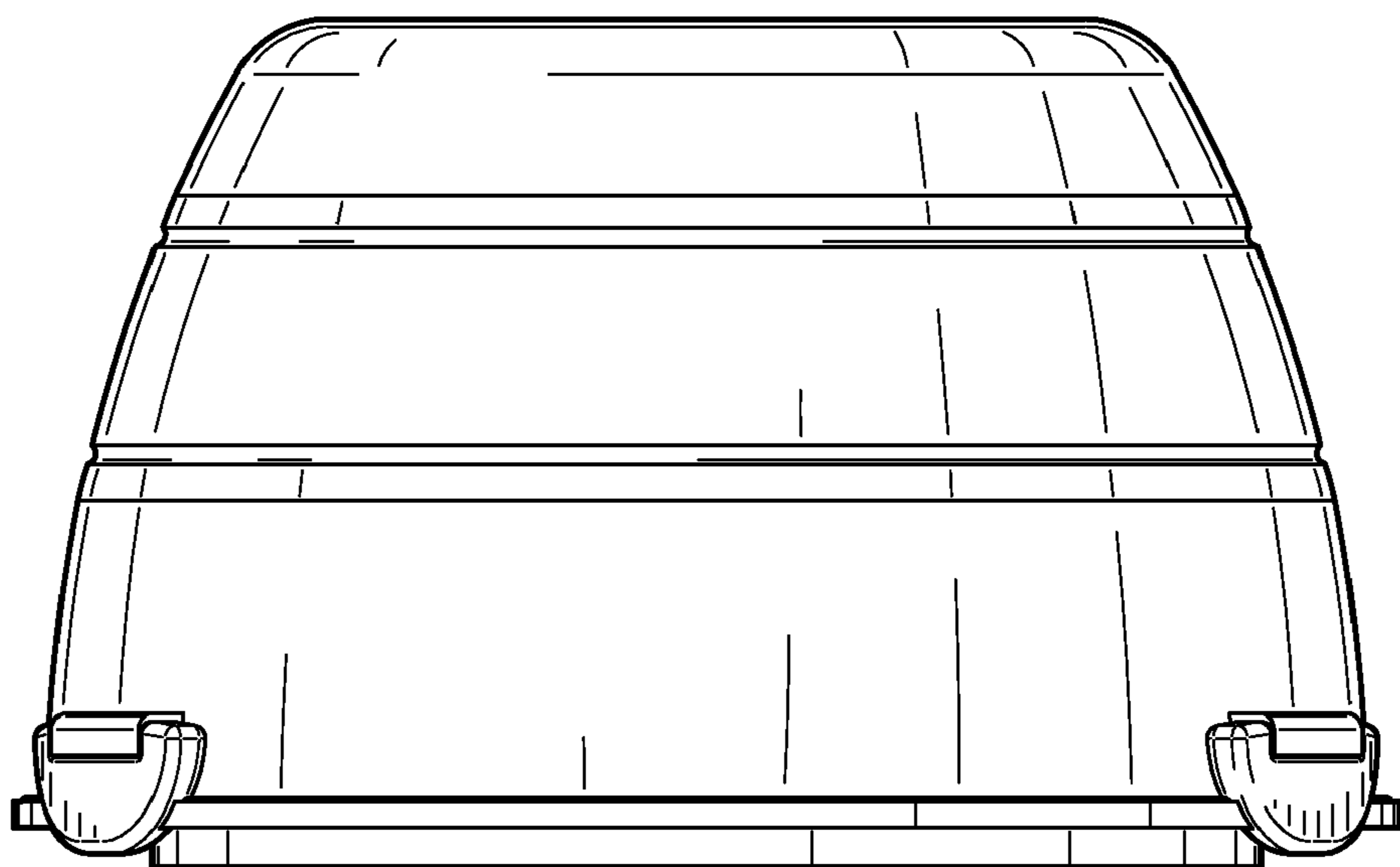

FIG. 5

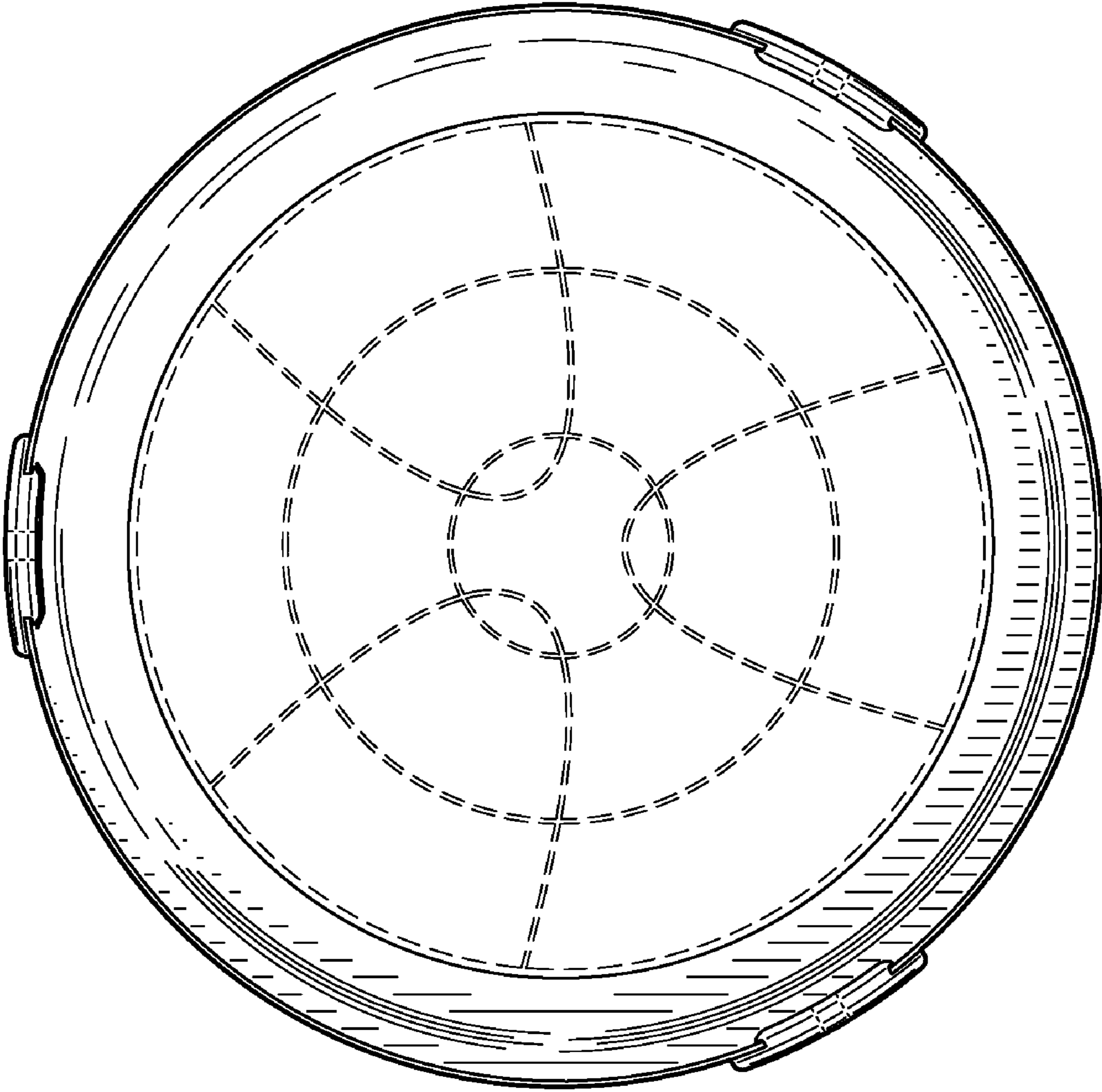

FIG.6