



US00D614281S

(12) **United States Design Patent**  
**Jeffrey**

(10) **Patent No.:** **US D614,281 S**

(45) **Date of Patent:** **\*\* Apr. 20, 2010**

(54) **IONIZER UNIT AND FRAME**

(75) Inventor: **David M. Jeffrey**, Colorado Springs, CO  
(US)

(73) Assignee: **A Major Difference, Inc.**, Aurora, CO  
(US)

(\*\*) Term: **14 Years**

(21) Appl. No.: **29/341,046**

(22) Filed: **Jul. 29, 2009**

(51) **LOC (9) Cl.** ..... **23-04**

(52) **U.S. Cl.** ..... **D23/386**

(58) **Field of Classification Search** ..... D23/386,  
D23/355-366, 351, 352, 369, 332-336, 342;  
422/120, 122; 55/356, 473, 504; 96/97;  
D14/188, 170-172, 214, 496; 261/DIG. 17,  
261/DIG. 65, DIG. 88, DIG. 31; 205/742-744;  
D24/170, 201, 204, 212, 213; D8/71, 74;  
33/42; 29/257; D15/141; 361/231

See application file for complete search history.

(56) **References Cited**

**U.S. PATENT DOCUMENTS**

3,373,740	A *	3/1968	Riepl	.....	D24/201
D282,715	S *	2/1986	Manning	.....	D8/74
5,535,089	A *	7/1996	Ford et al.	.....	361/231
D380,953	S *	7/1997	Norgaard	.....	D8/71
D390,241	S *	2/1998	Mori	.....	D8/71
D453,215	S *	1/2002	Summers et al.	.....	D23/365

D454,946	S *	3/2002	Jackson	.....	D23/366
D481,281	S *	10/2003	Anderson	.....	D8/71
6,716,335	B2 *	4/2004	Takesako et al.	.....	205/742
7,160,434	B2 *	1/2007	Becker et al.	.....	205/742
D572,354	S *	7/2008	Tsuchiya et al.	.....	D23/355
D574,070	S *	7/2008	Dabrowski	.....	D23/342
7,392,589	B2 *	7/2008	Friegang	.....	33/42

\* cited by examiner

*Primary Examiner*—T. Chase Nelson

*Assistant Examiner*—David G Muller

(74) *Attorney, Agent, or Firm*—Dorsey & Whitney LLP

(57) **CLAIM**

The ornamental design for a ionizer unit and frame, as shown and described.

**DESCRIPTION**

FIG. 1 is a front isometric view of an ionizer unit and frame of the present invention;

FIG. 2 is a top plan view thereof;

FIG. 3 is a front elevation view thereof;

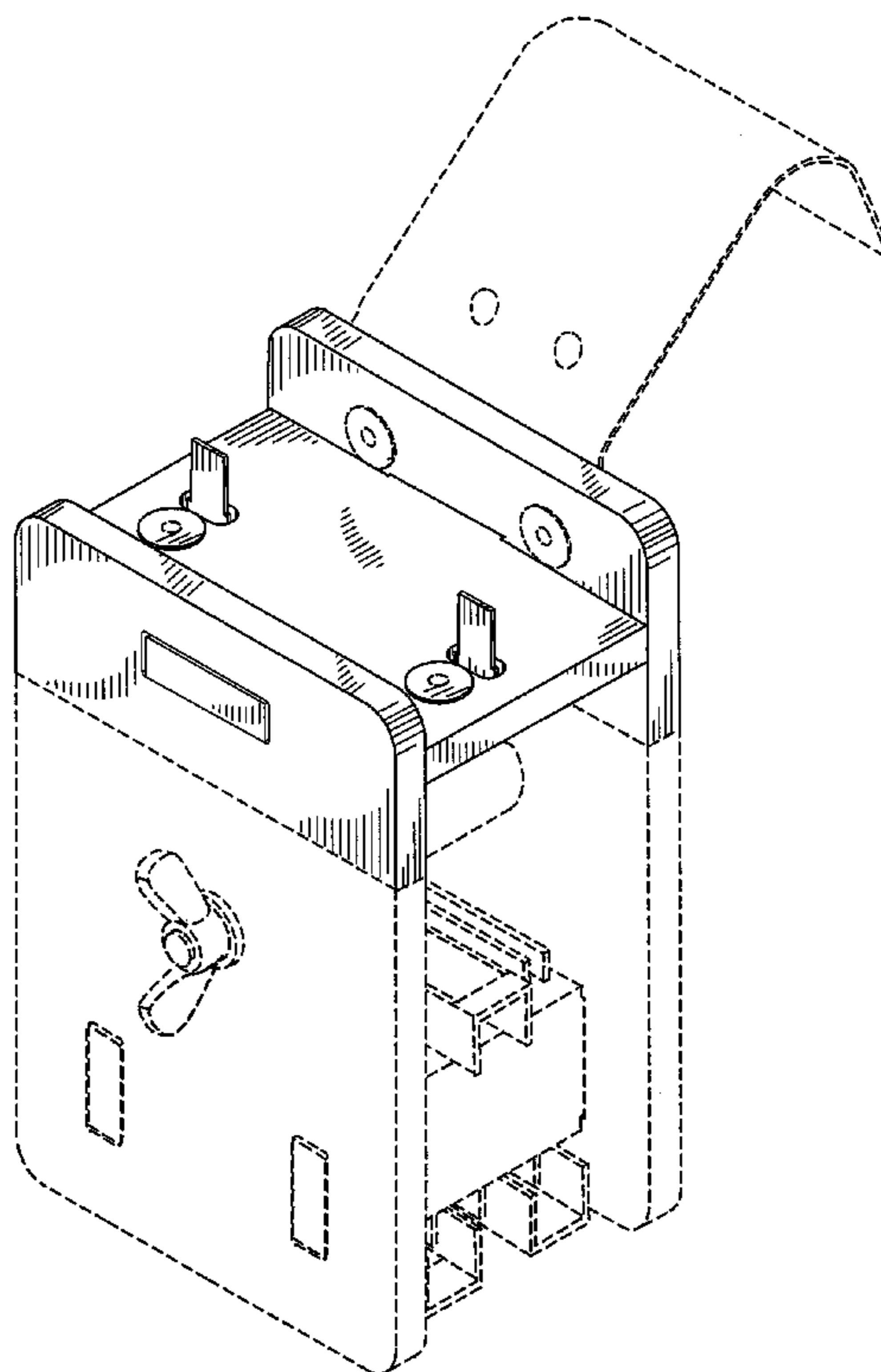
FIG. 4 is a bottom plan view thereof;

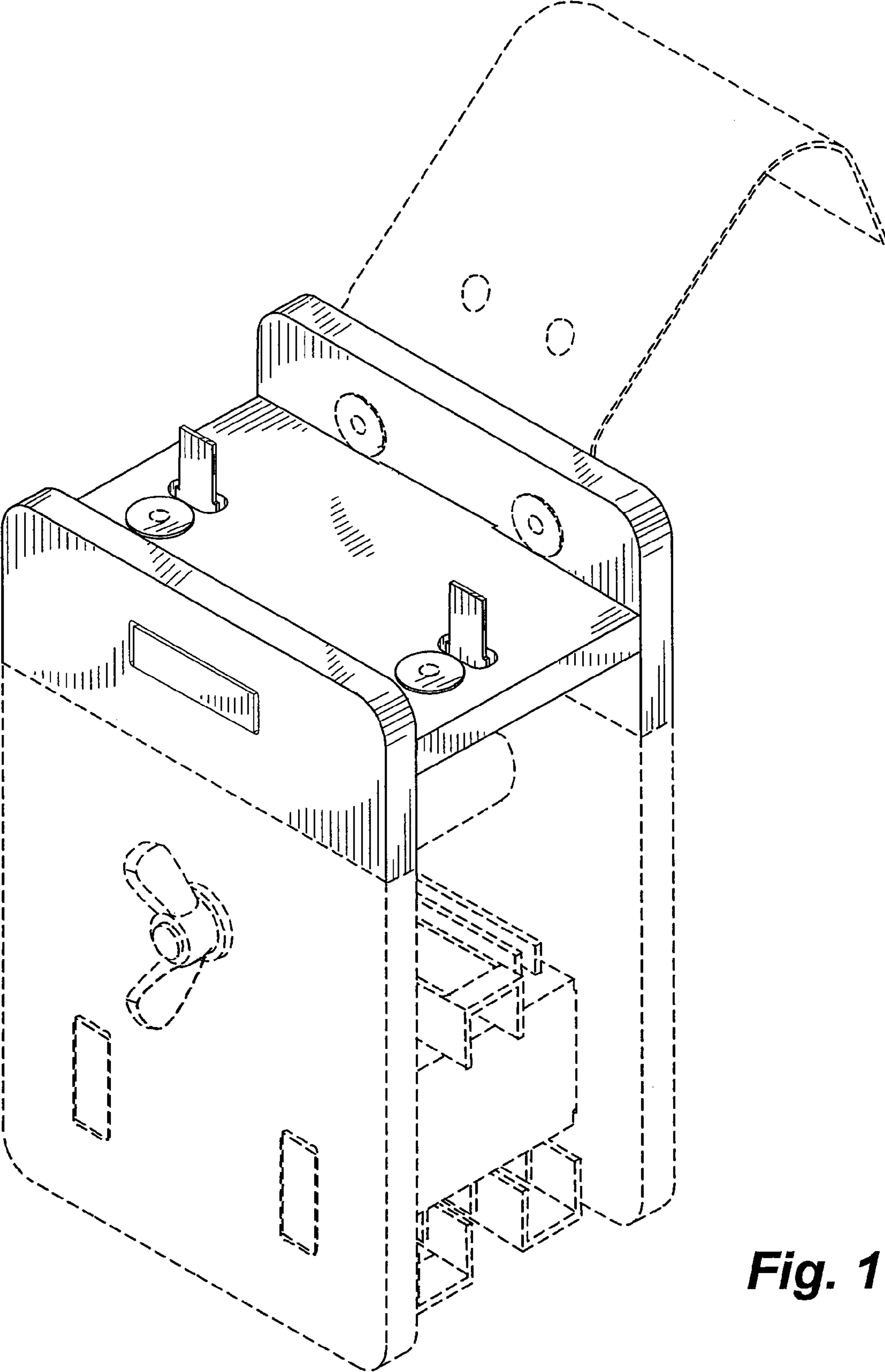
FIG. 5 is a right side elevation view thereof, the left side elevation view being a mirror image; and,

FIG. 6 is a rear elevation view thereof.

The broken line showing of parts of the drawings is included for the purpose of illustrating use and environment and forms no part of the claimed design.

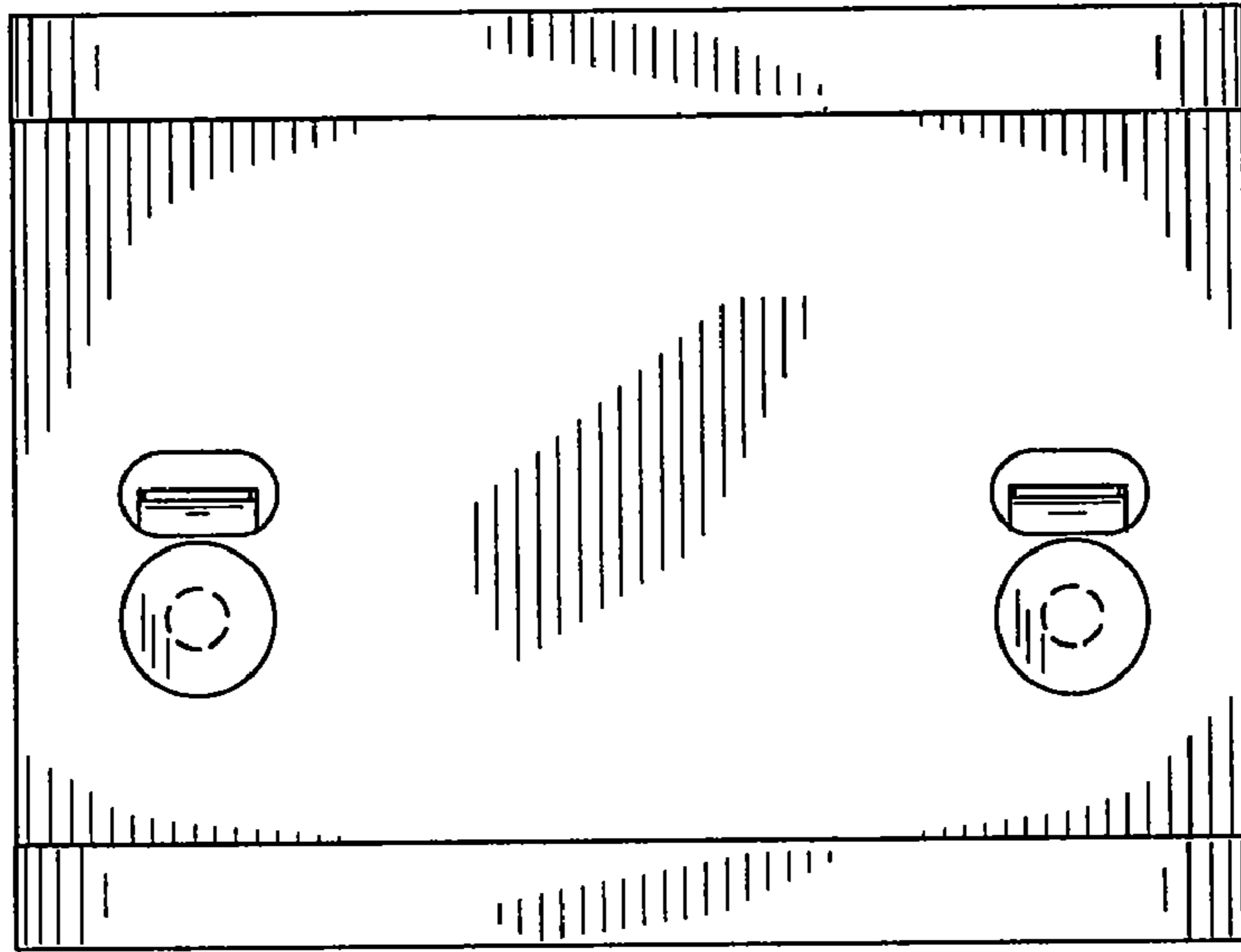
**1 Claim, 3 Drawing Sheets**



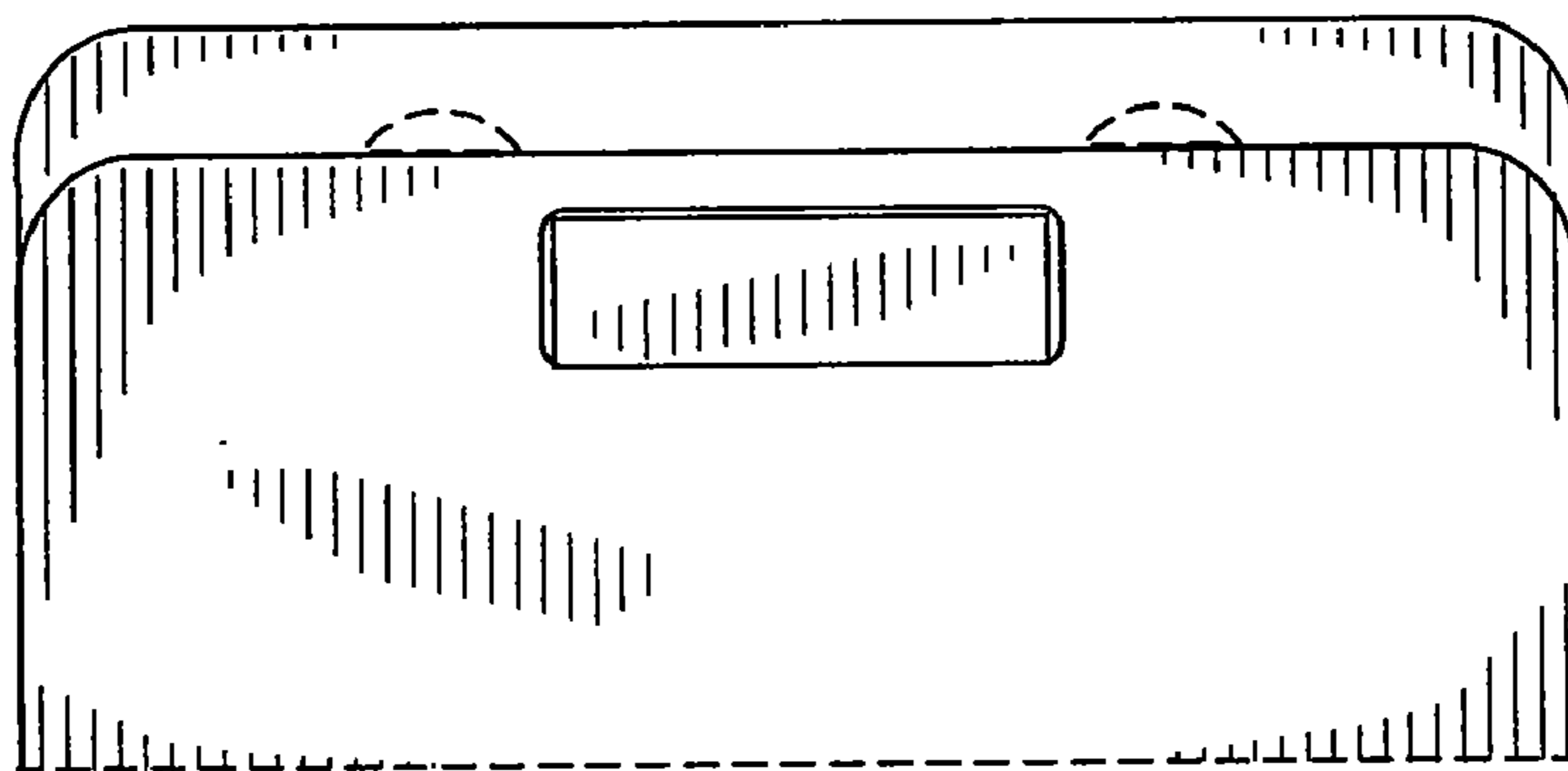


**Fig. 1**

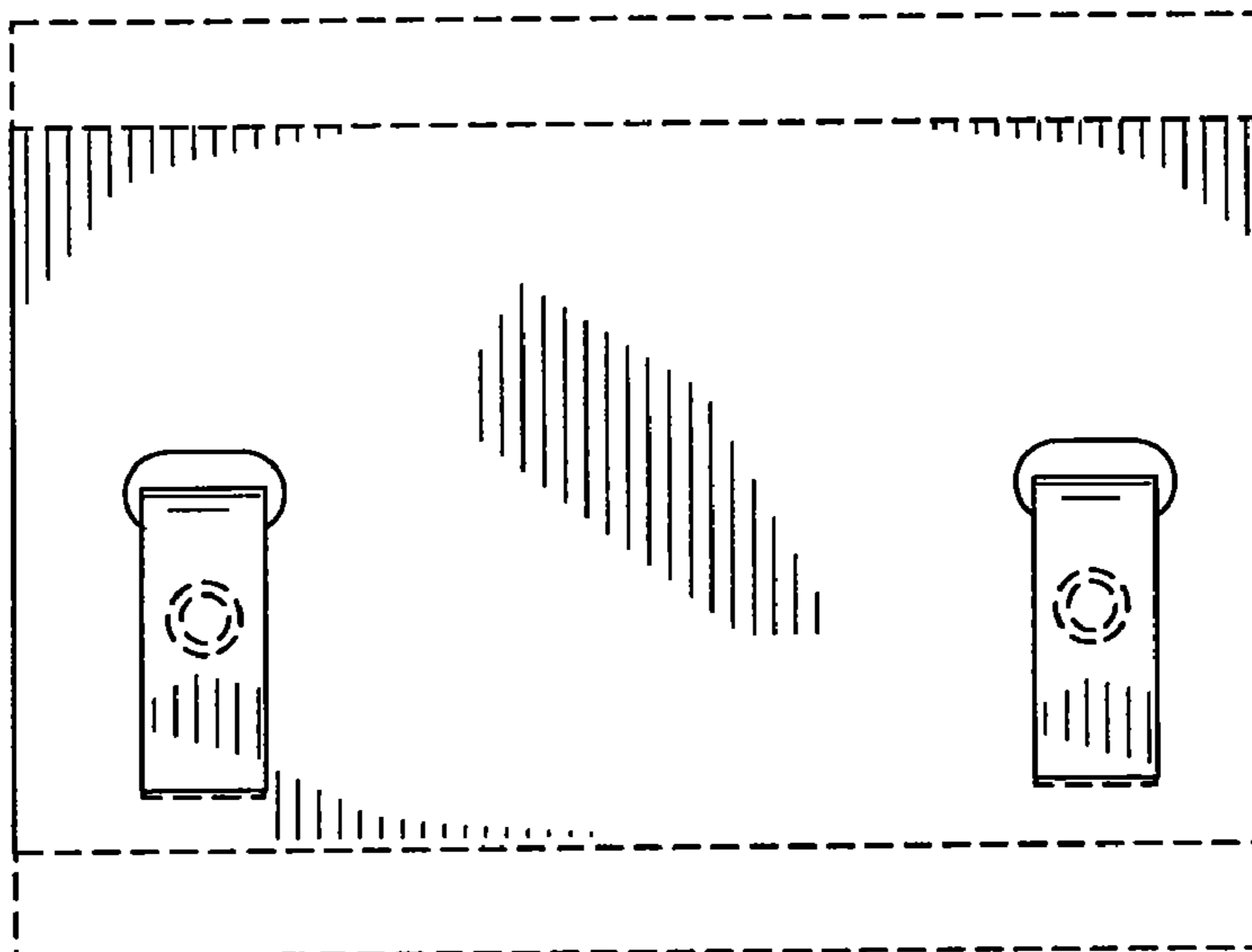
**Fig. 2**



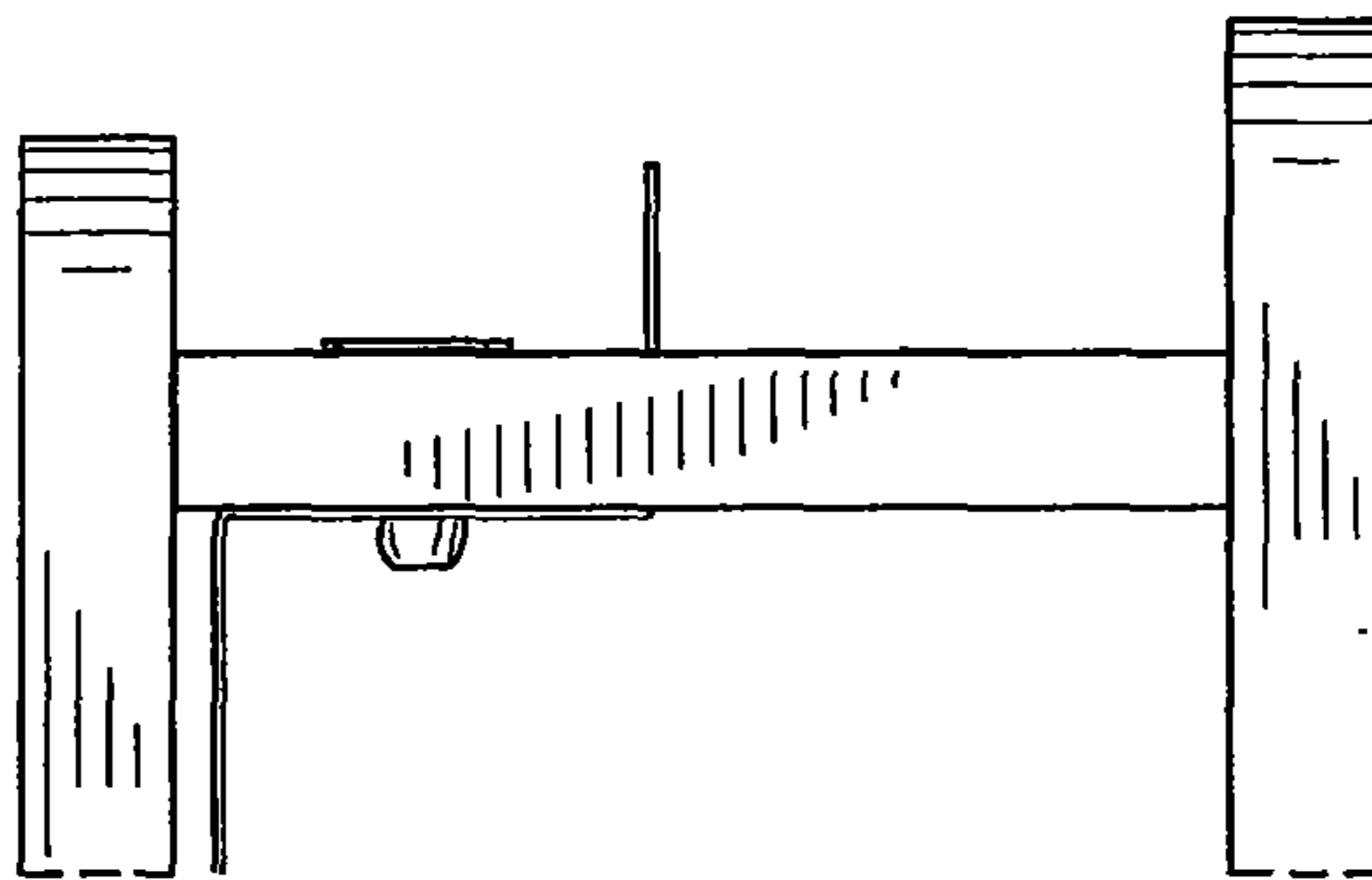
**Fig. 3**



**Fig. 4**



**Fig. 5**



**Fig. 6**

