



US00D614207S

(12) **United States Design Patent**
Ruvang

(10) **Patent No.:** **US D614,207 S**
(45) **Date of Patent:** **** *Apr. 20, 2010**

- (54) **GROUND ENGAGING WEAR MEMBER**
- (75) Inventor: **John A. Ruvang**, Lake Dallas, TX (US)
- (73) Assignee: **Hensley Industries, Inc.**, Dallas, TX (US)
- (**) Term: **14 Years**
- (21) Appl. No.: **29/343,321**
- (22) Filed: **Sep. 10, 2009**

Related U.S. Application Data

(62) Division of application No. 29/298,828, filed on Dec. 13, 2007, now Pat. No. Des. 602,505.

- (51) **LOC (9) Cl.** **15-03**
- (52) **U.S. Cl.** **D15/29**
- (58) **Field of Classification Search** D15/25, D15/28, 29; 37/450, 452-455, 446, 465
See application file for complete search history.

(56) **References Cited**

U.S. PATENT DOCUMENTS

4,231,173 A * 11/1980 Davis 37/457
(Continued)

FOREIGN PATENT DOCUMENTS

AR 78084 8/2008
(Continued)

OTHER PUBLICATIONS

Examination Report dated Oct. 30, 2009, by the Colombian Patent Office, regarding Colombian Industrial Design Application 08-61054 (6 pages).

(Continued)

Primary Examiner—Mark A Goodwin
(74) *Attorney, Agent, or Firm*—Haynes and Boone, LLP

(57) **CLAIM**

The ornamental design for a ground engaging wear member, as shown and described.

DESCRIPTION

FIG. 1 is a perspective view of the ground engaging wear member showing my new design according to a first embodiment;

FIG. 2 is another perspective view of the first embodiment;
 FIG. 3 is an elevational view of the first embodiment;
 FIG. 4 is a sectional view of the first embodiment taken along line 4—4 of FIG. 1;
 FIG. 5 is a sectional view of the first embodiment taken along line 5—5 of FIG. 2;
 FIG. 6 is a sectional view of the first embodiment taken along line 6—6 of FIG. 1;
 FIG. 7 is a sectional view of the first embodiment taken along line 7—7 of FIG. 2;
 FIG. 8 is a perspective view of the ground engaging wear member showing my new design according to a second embodiment;
 FIG. 9 is another perspective view of the second embodiment;
 FIG. 10 is an elevational view of the second embodiment;
 FIG. 11 is a sectional view of the second embodiment taken along line 11—11 of FIG. 8;
 FIG. 12 is a sectional view of the second embodiment taken along line 12—12 of FIG. 9;
 FIG. 13 is a sectional view of the second embodiment taken along line 13—13 of FIG. 8;
 FIG. 14 is a sectional view of the second embodiment taken along line 14—14 of FIG. 9;
 FIG. 15 is a perspective view of the ground engaging wear member showing my new design according to a third embodiment;
 FIG. 16 is another perspective view of the third embodiment;
 FIG. 17 is an elevational view of the third embodiment;
 FIG. 18 is a sectional view of the third embodiment taken along line 18—18 of FIG. 15;
 FIG. 19 is a sectional view of the third embodiment taken along line 19—19 of FIG. 16;
 FIG. 20 is a sectional view of the third embodiment taken along line 20—20 of FIG. 15; and,
 FIG. 21 is a sectional view of the third embodiment taken along line 21—21 of FIG. 16.

Any broken line illustration of environmental structure in the drawings is not part of the design sought to be patented.

1 Claim, 21 Drawing Sheets

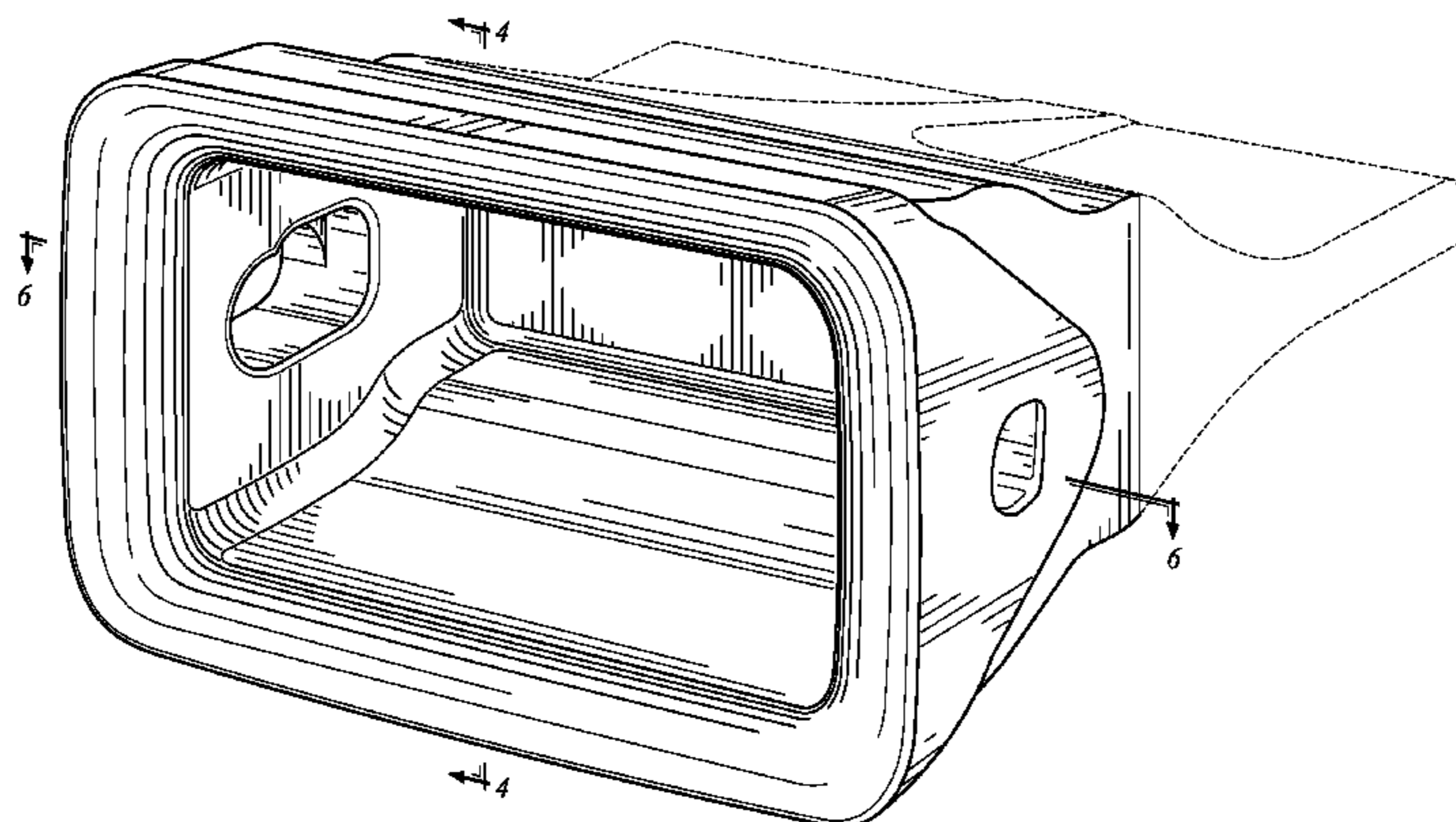

US D614,207 S

Page 2

U.S. PATENT DOCUMENTS

4,965,945 A * 10/1990 Emrich 37/456
5,018,283 A * 5/1991 Fellner 37/452
D329,243 S * 9/1992 Robinson D15/29
5,311,681 A 5/1994 Ruvang et al.
5,331,754 A 7/1994 Ruvang
5,394,629 A 3/1995 Ruvang et al.
D363,074 S 10/1995 Ruvang
D365,109 S 12/1995 Robinson et al.
D365,577 S 12/1995 Ruvang
5,564,206 A 10/1996 Ruvang
5,713,145 A 2/1998 Ruvang
5,718,070 A 2/1998 Ruvang
5,765,301 A * 6/1998 Clendenning 37/457
5,802,752 A * 9/1998 Quarfordt 37/452
D413,338 S * 8/1999 Pueyo Molina D15/29
5,937,550 A * 8/1999 Emrich 37/458
6,041,529 A 3/2000 Ruvang
D430,172 S * 8/2000 Kesavan D15/28
6,108,950 A 8/2000 Ruvang et al.
D435,567 S * 12/2000 Clendenning D15/29
D436,116 S * 1/2001 Clendenning D15/29
6,209,238 B1 4/2001 Ruvang
6,247,255 B1 * 6/2001 Clendenning 37/452
D447,154 S * 8/2001 Clendenning D15/29
6,393,739 B1 5/2002 Shamblin et al.
6,439,796 B1 8/2002 Ruvang et al.
D471,212 S * 3/2003 Toral Rodriguez D15/28
D471,565 S * 3/2003 Toral Rodriguez D15/28
6,564,482 B2 5/2003 Ruvang

6,826,855 B2 12/2004 Ruvang
6,976,325 B2 12/2005 Robinson et al.
7,100,315 B2 * 9/2006 Carpenter et al. 37/454
7,162,818 B2 1/2007 Ruvang et al.
D602,505 S 10/2009 Ruvang
2004/0107608 A1 * 6/2004 Meyers et al. 37/452
2004/0172866 A1 * 9/2004 Moreno et al. 37/455
2006/0010725 A1 * 1/2006 Jackson 37/456
2006/0010726 A1 * 1/2006 Emrich et al. 37/456
2006/0117613 A1 * 6/2006 Jones et al. 37/456
2006/0265916 A1 * 11/2006 Carpenter et al. 37/452
2007/0000157 A1 * 1/2007 Emrich 37/452

FOREIGN PATENT DOCUMENTS

RU 61706 2/2007
RU 64078 9/2007
WO WO2003016640 2/2003
WO WO2004042153 5/2004
WO WO2005017268 2/2005

OTHER PUBLICATIONS

Office Action mailed Sep. 5, 2008, by the USPTO, regarding U.S. Appl. No. 29/298,828 (5 pages).
Office Action mailed Feb. 4, 2009, by the USPTO, regarding U.S. Appl. No. 29/298,828 (5 pages).
Notice of Allowance mailed Jun. 12, 2009, by the USPTO, regarding U.S. Appl. No. 29/298,828 (7 pages).
U.S. Appl. No. 29/343,314, filed Sep. 10, 2009, Ruvang.

* cited by examiner

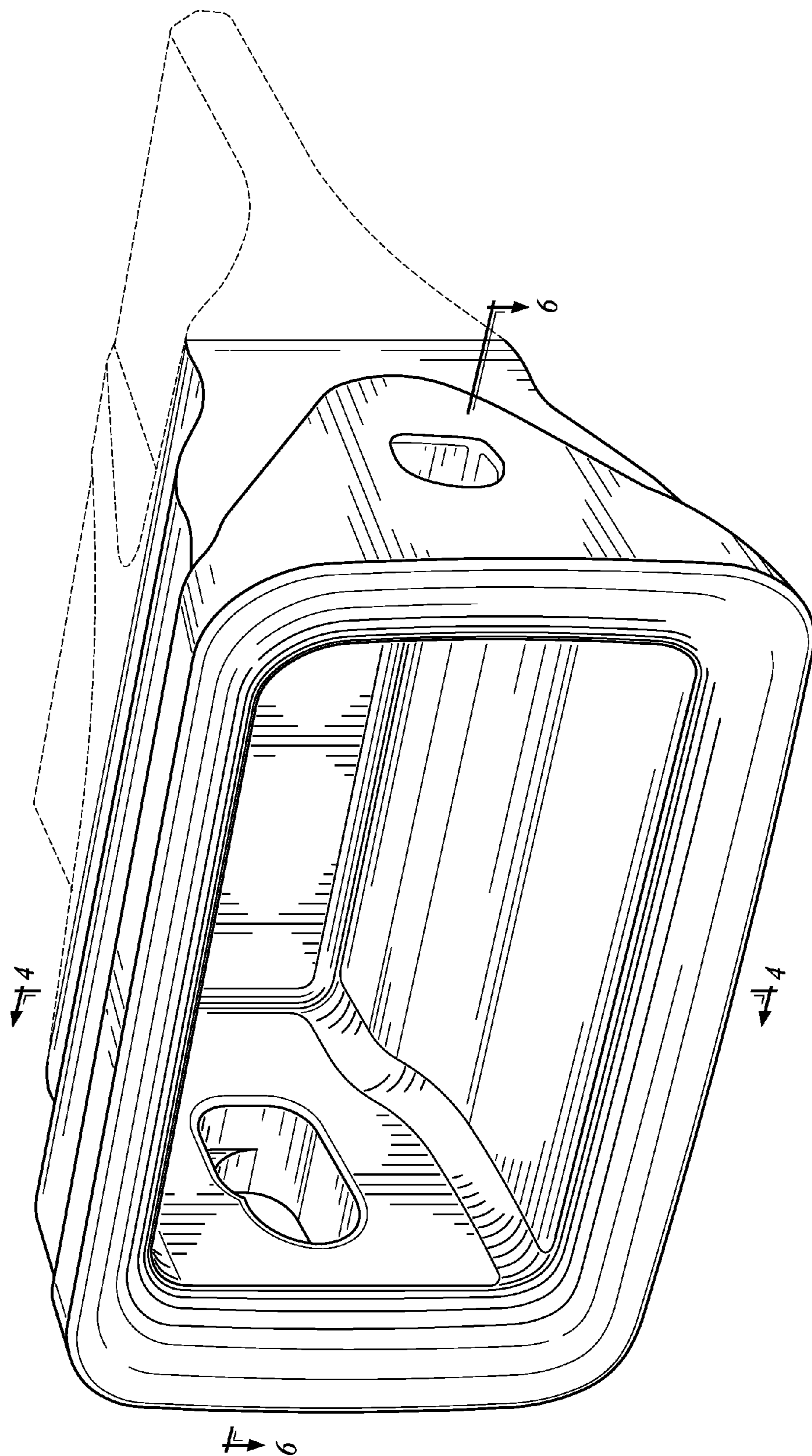

Fig. 1

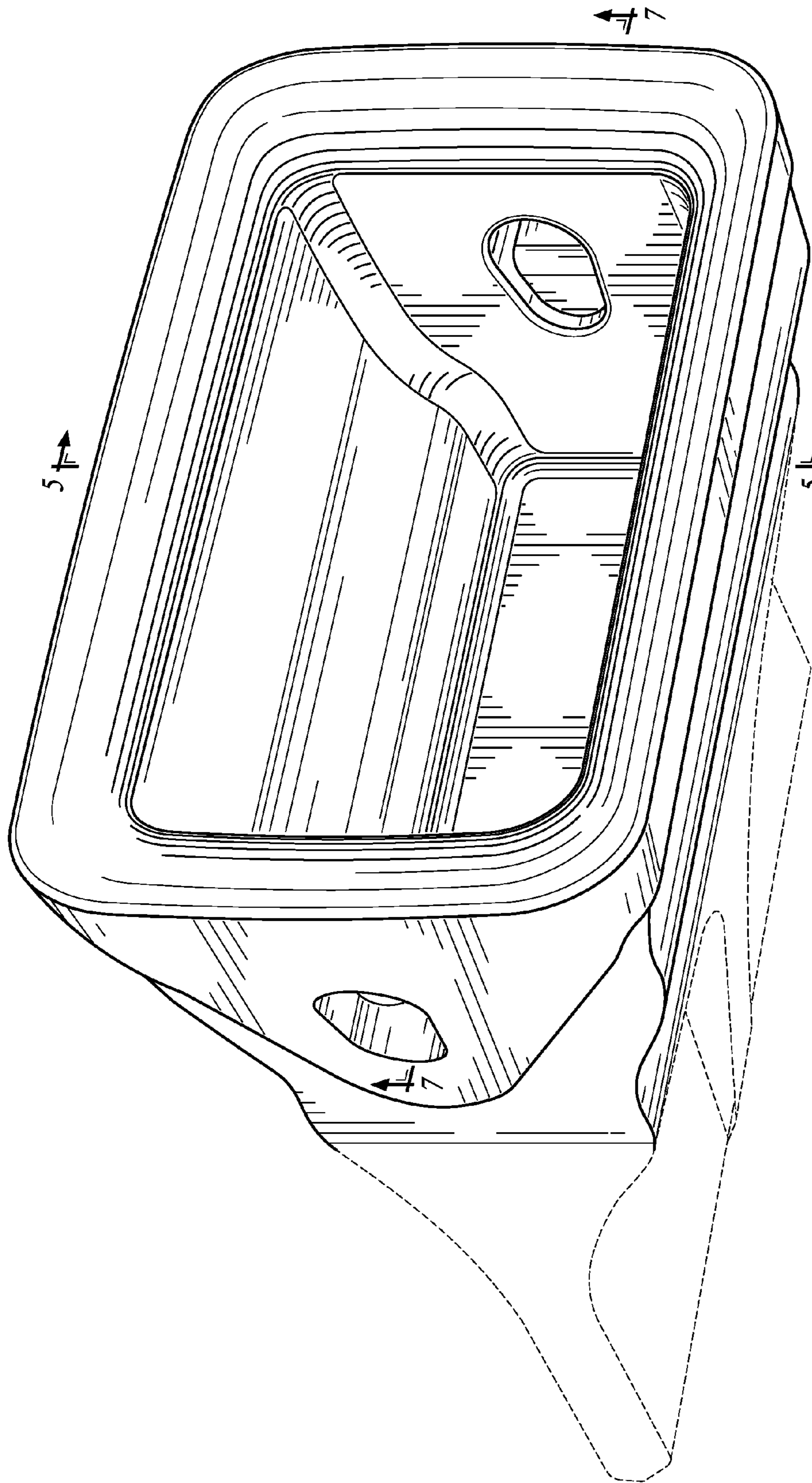

Fig. 2

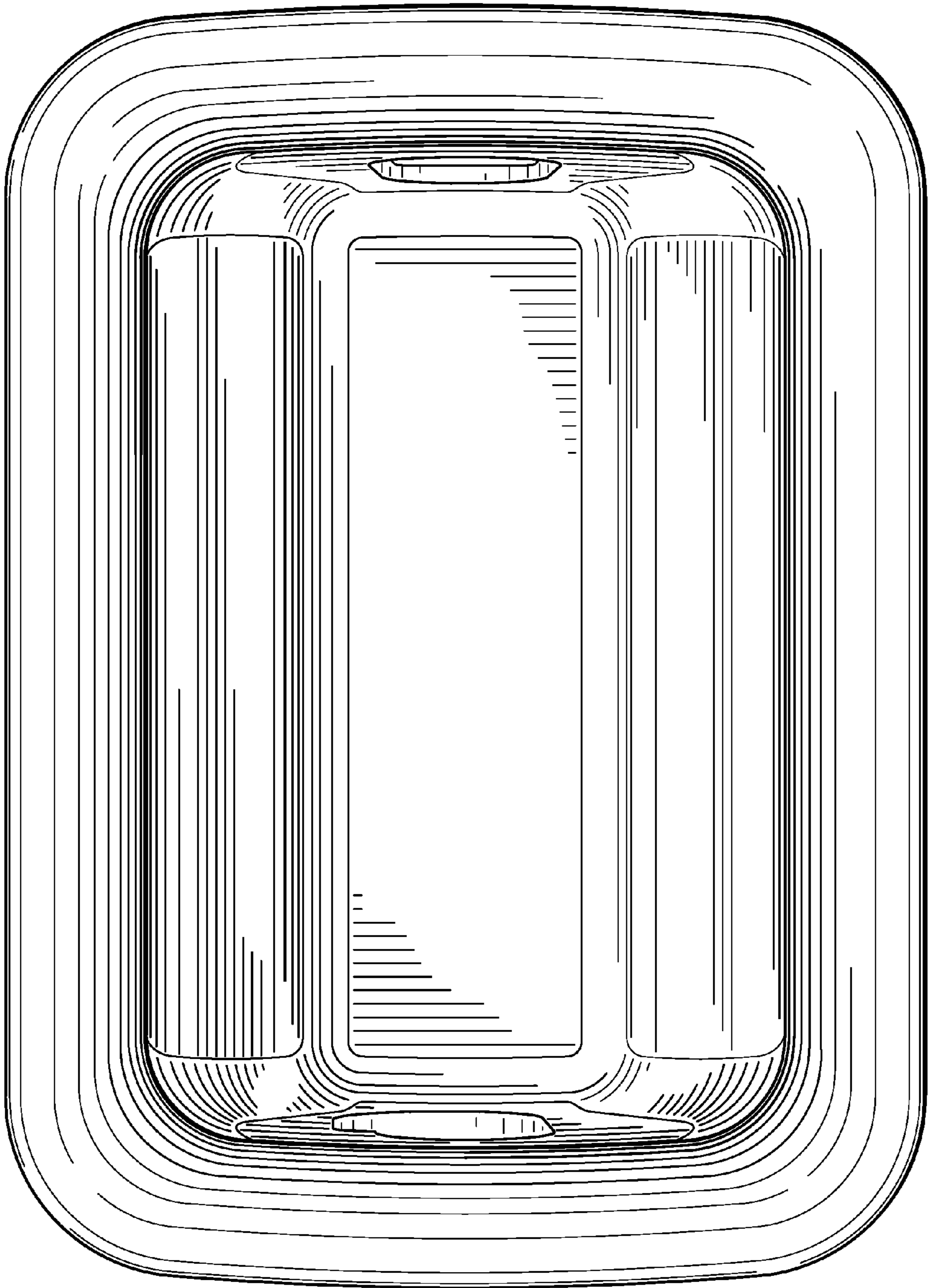

Fig. 3

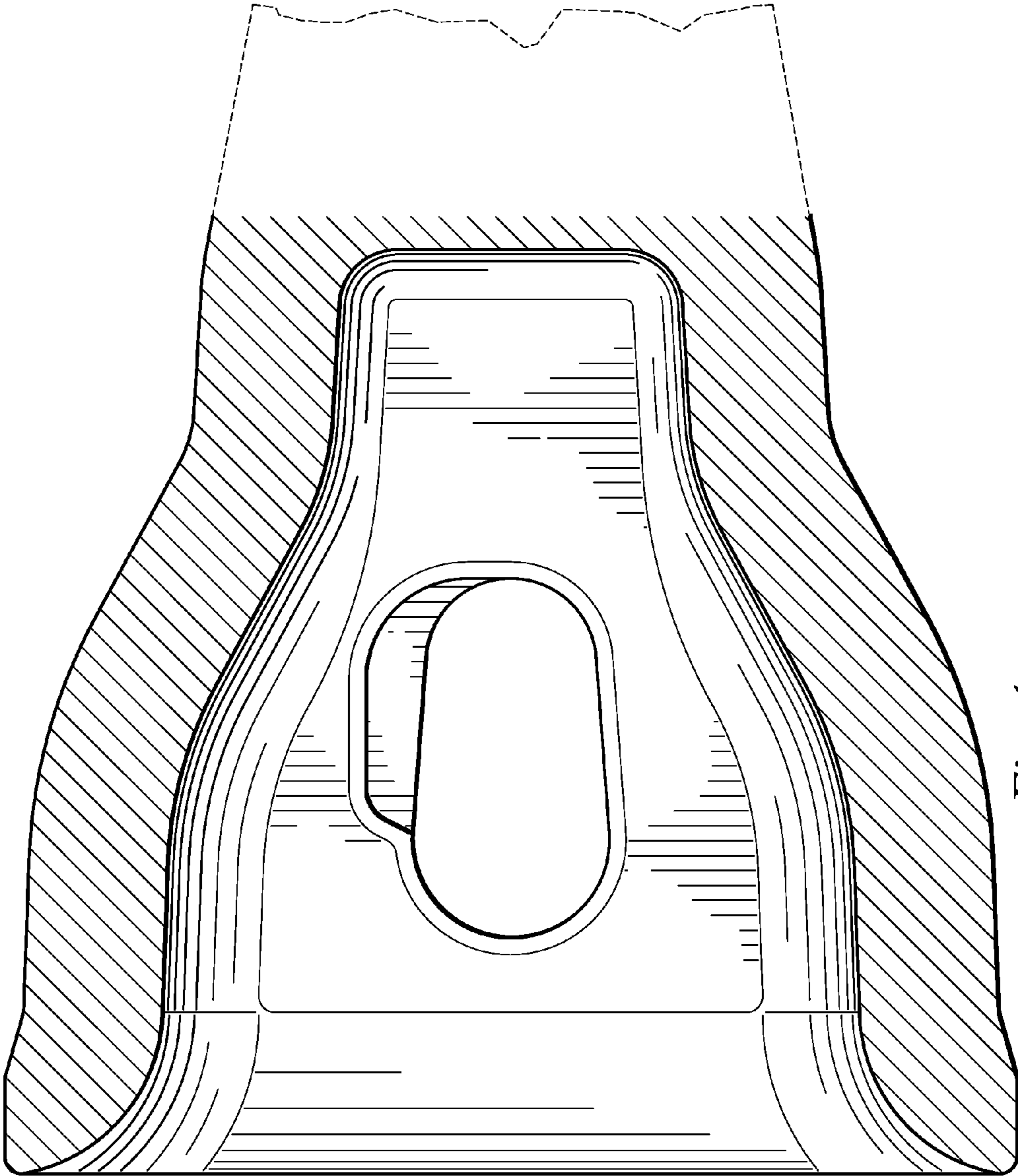

Fig. 4

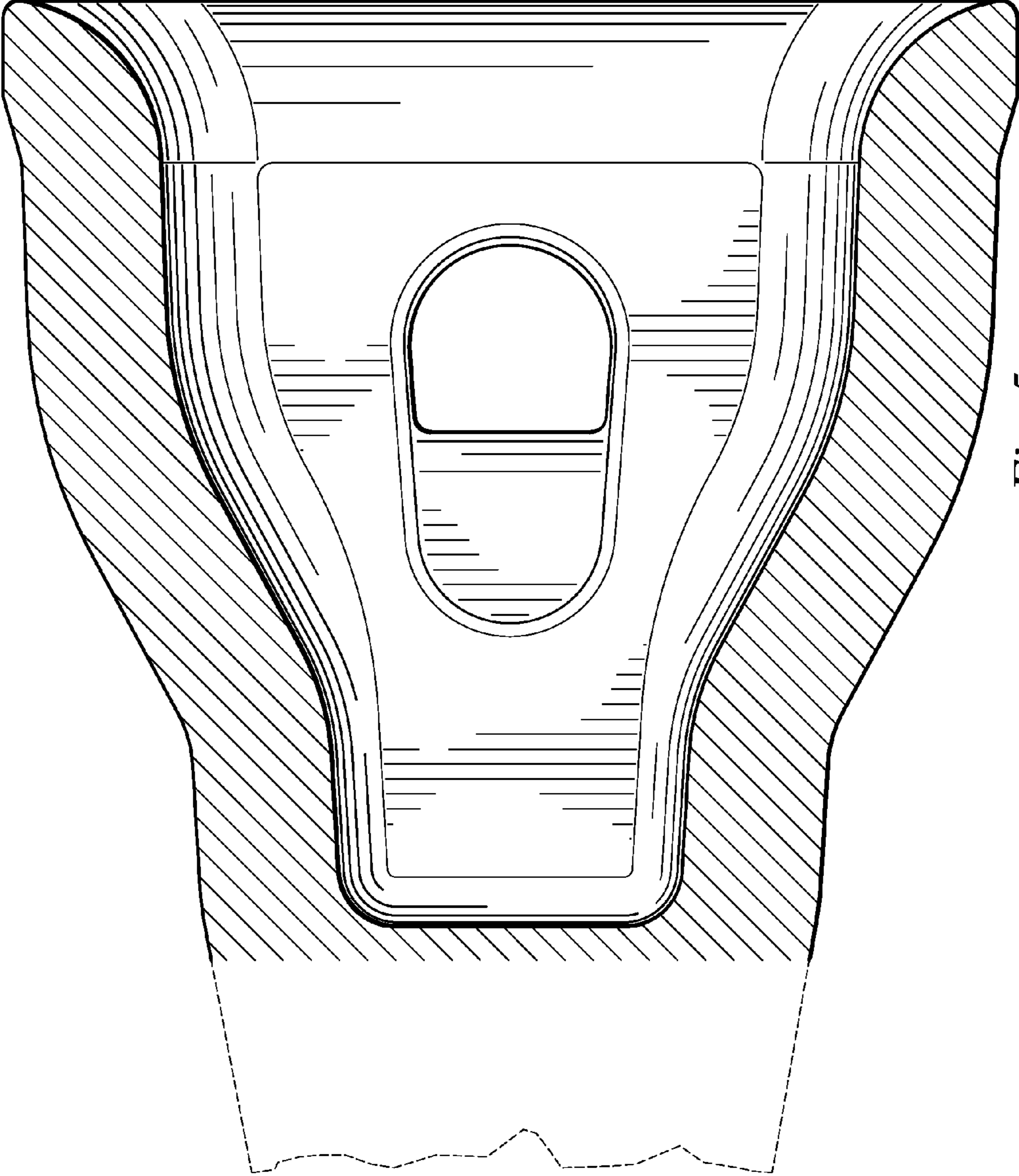

Fig. 5

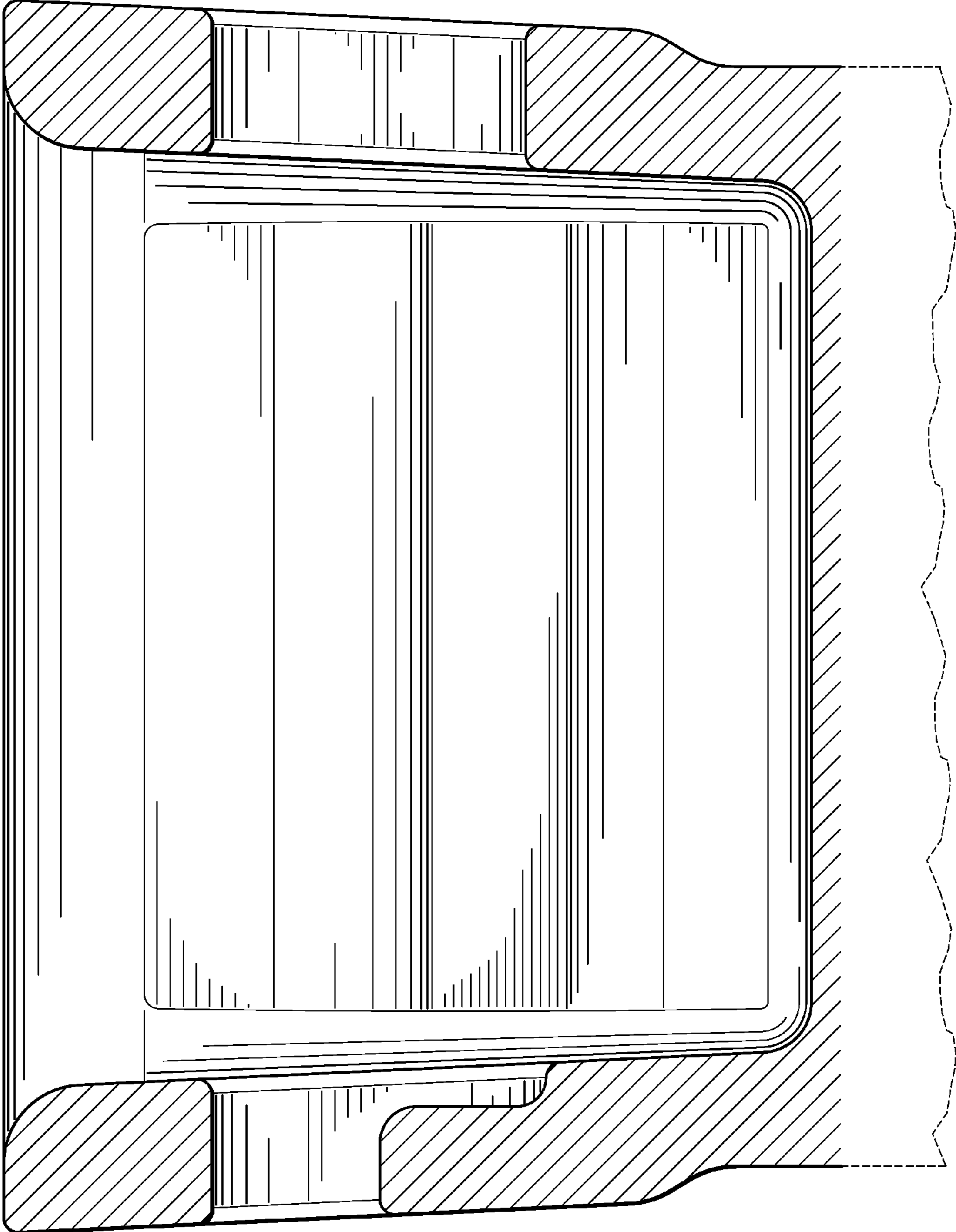

Fig. 6

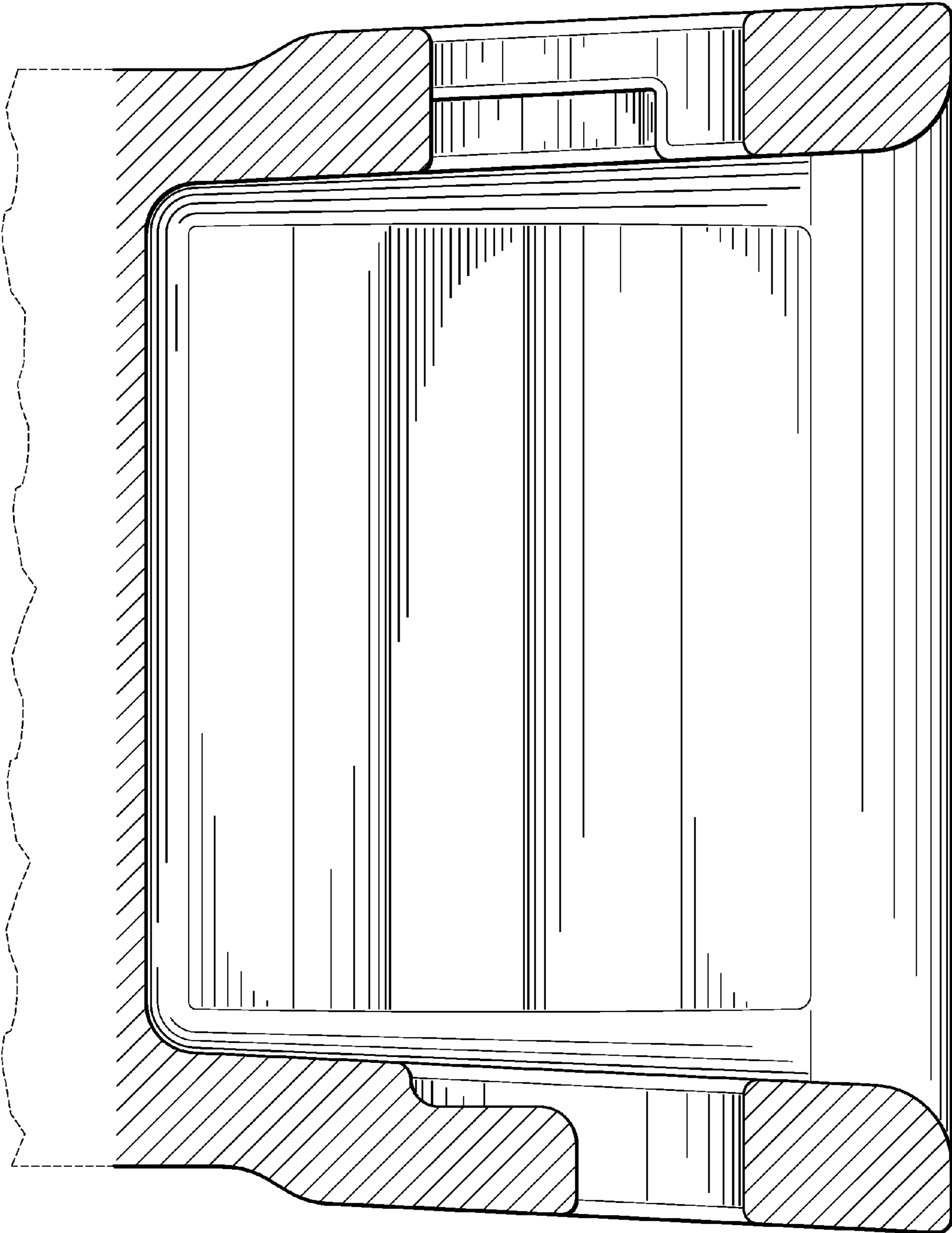

Fig. 7

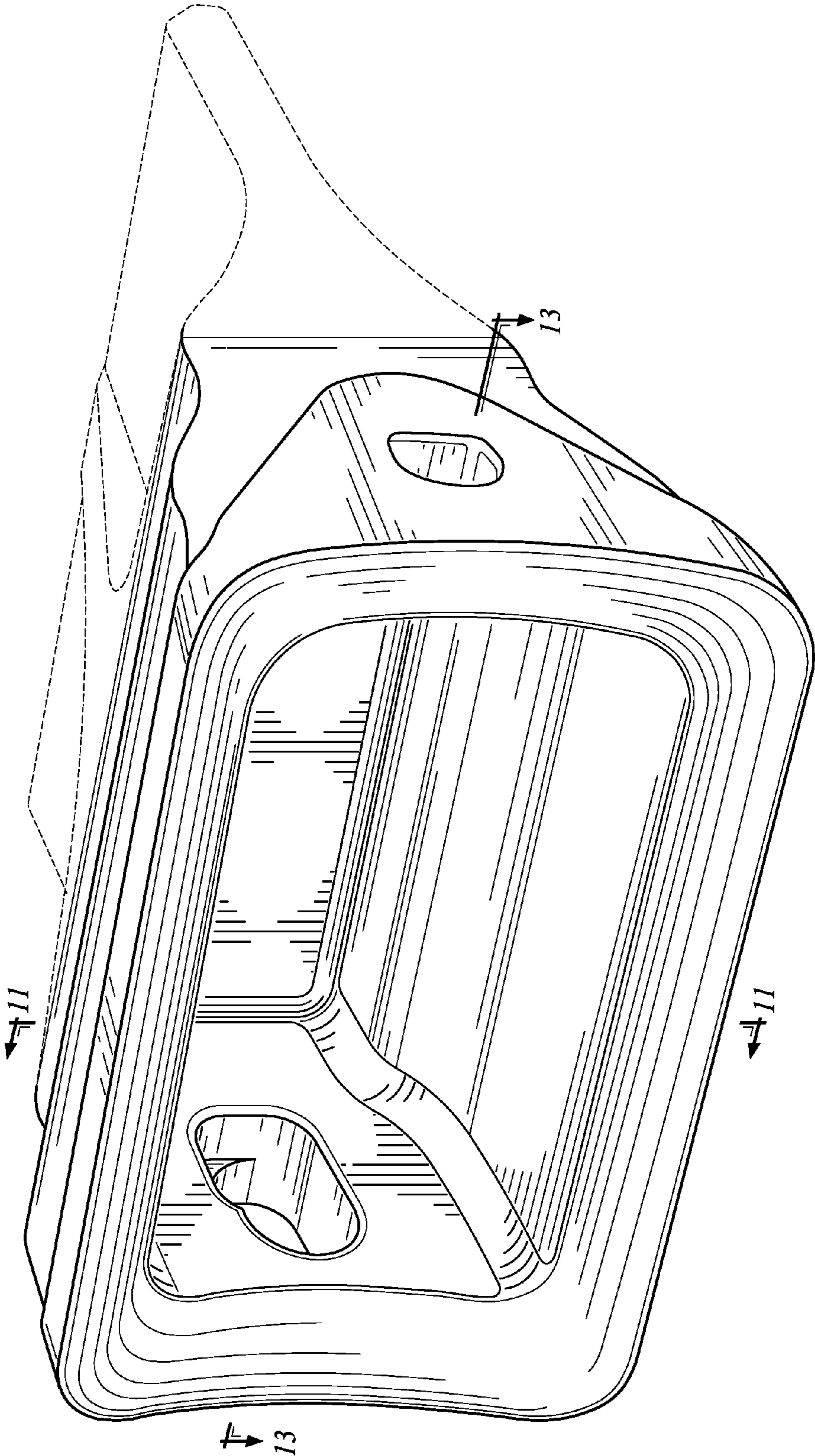

Fig. 8

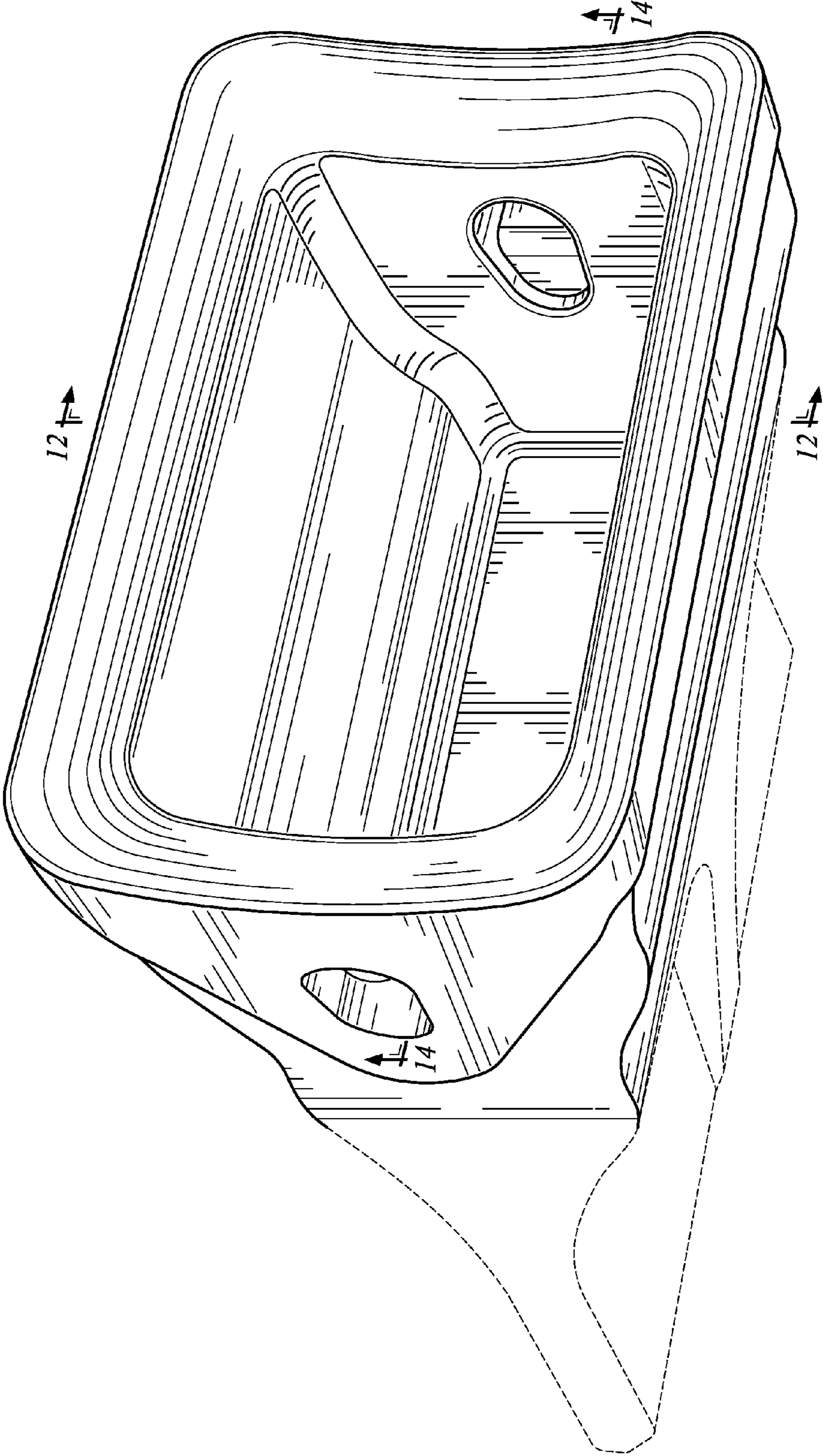

Fig. 9

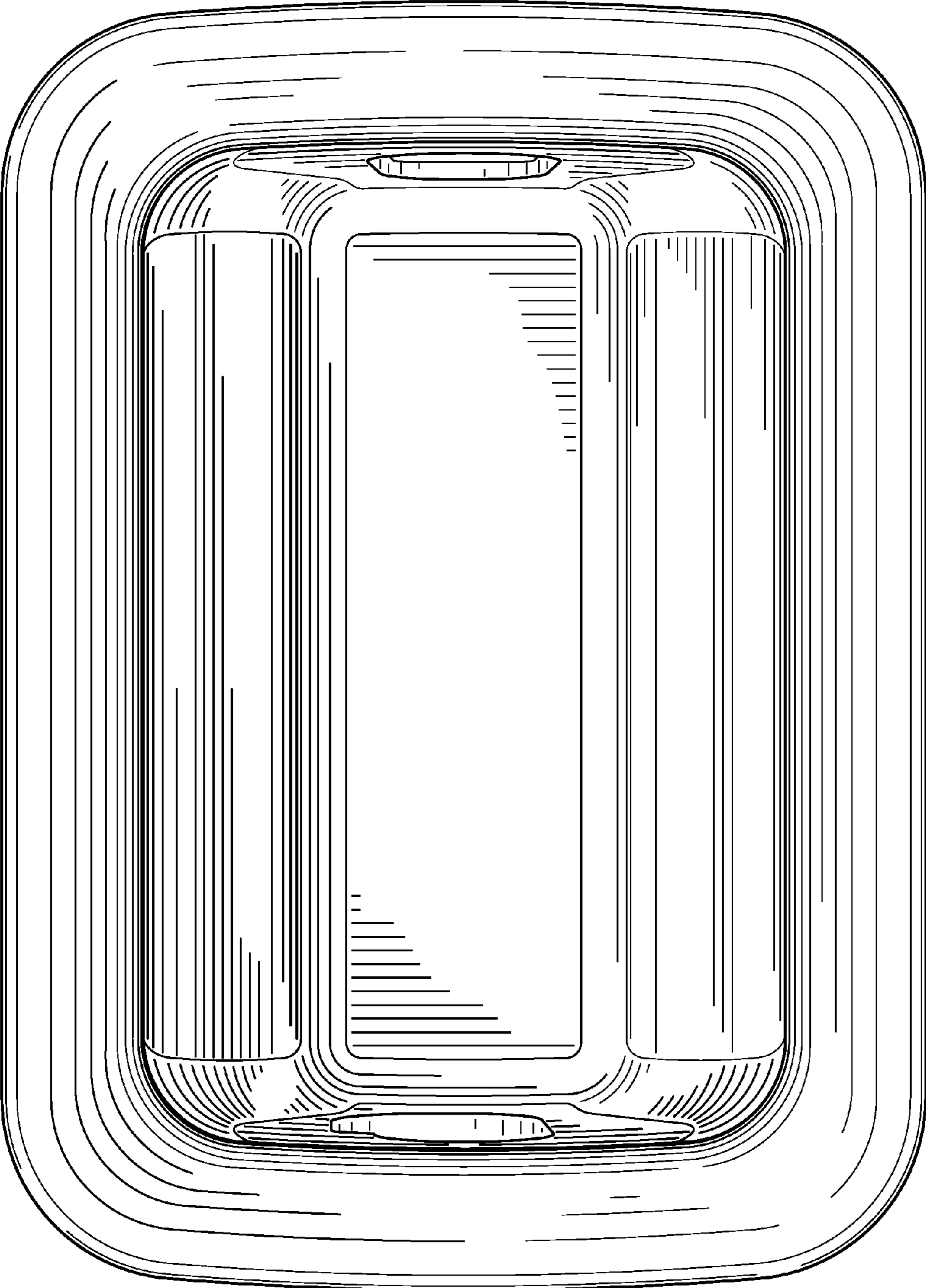

Fig. 10

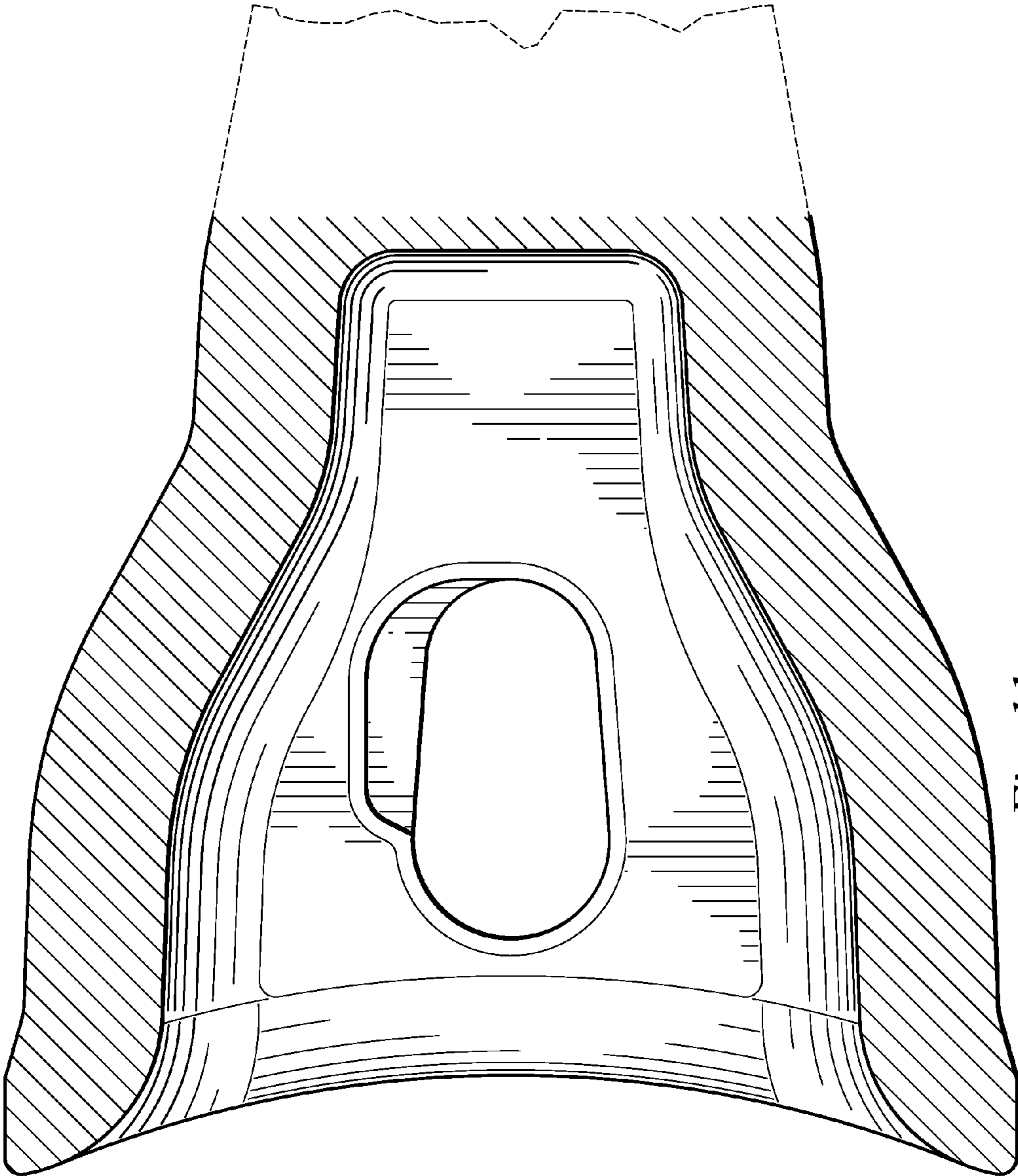

Fig. 11

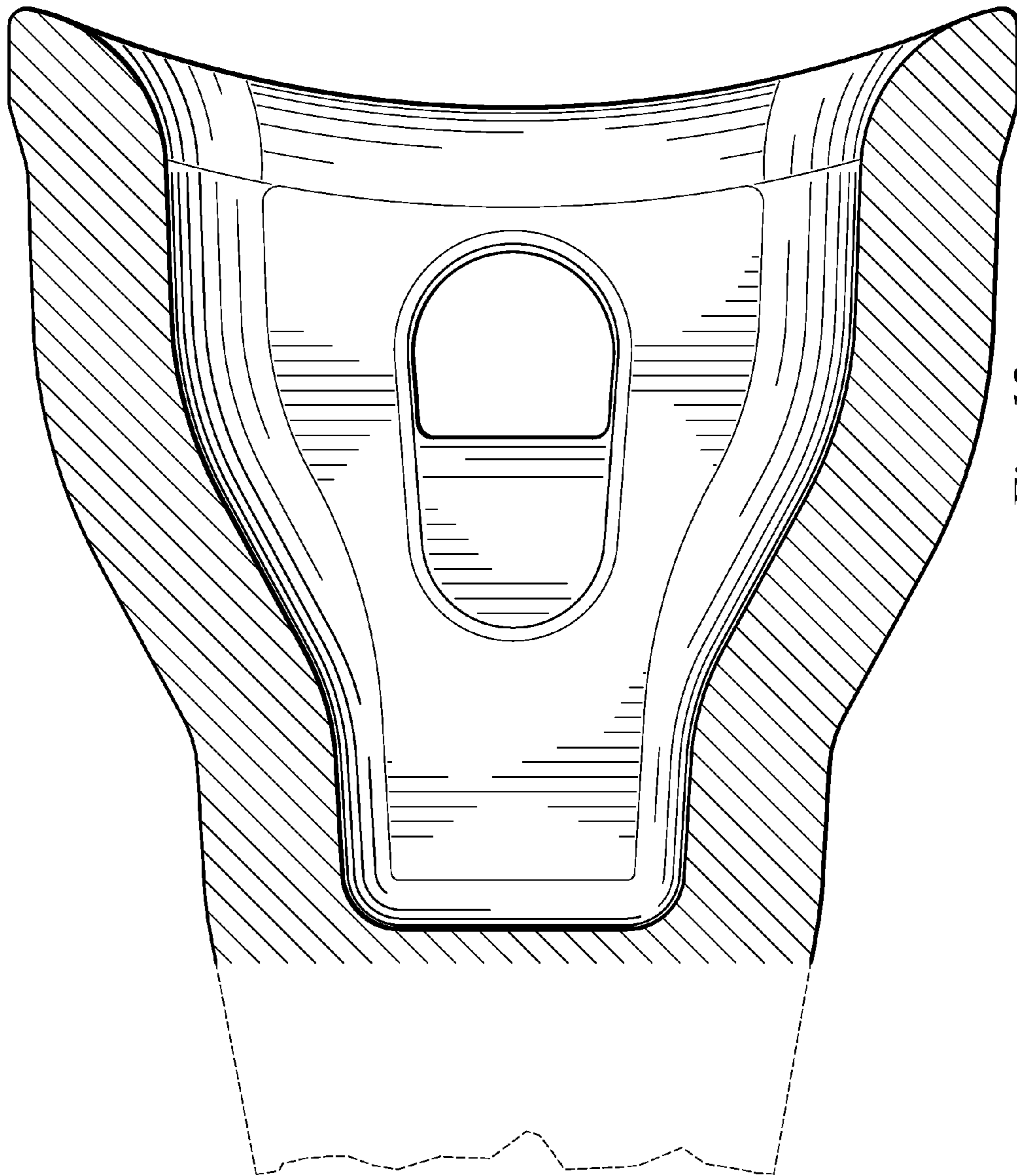

Fig. 12

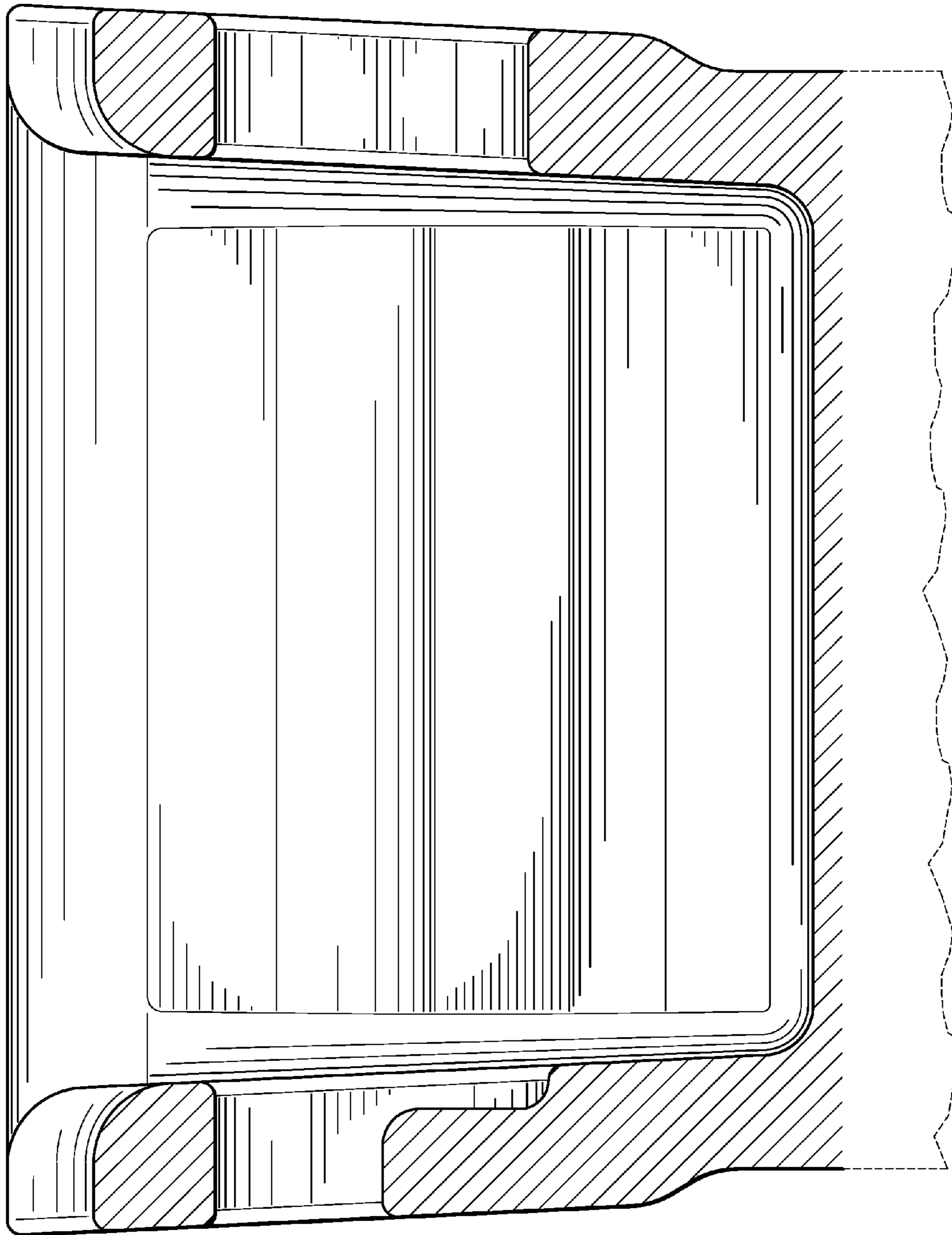

Fig. 13

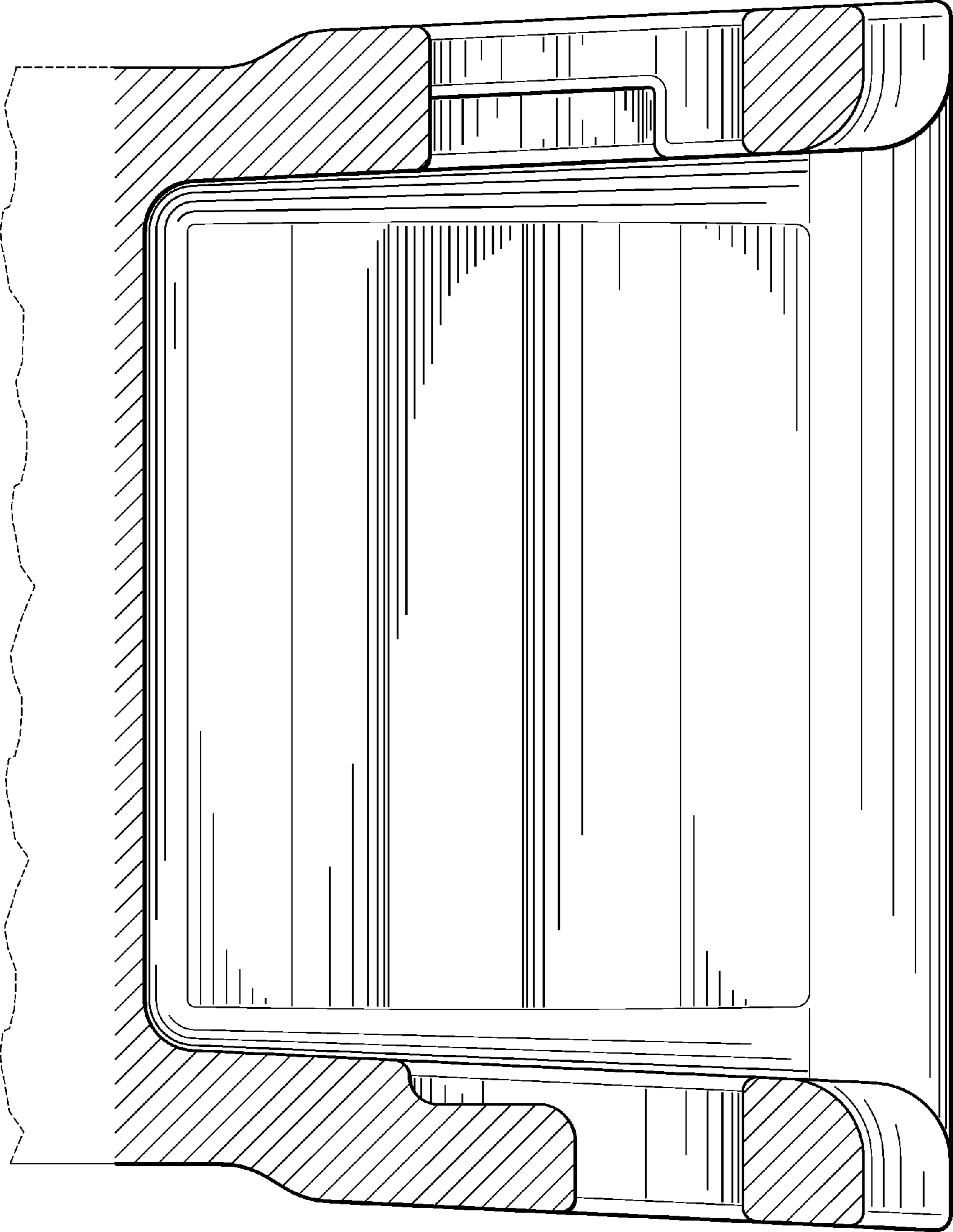

Fig. 14

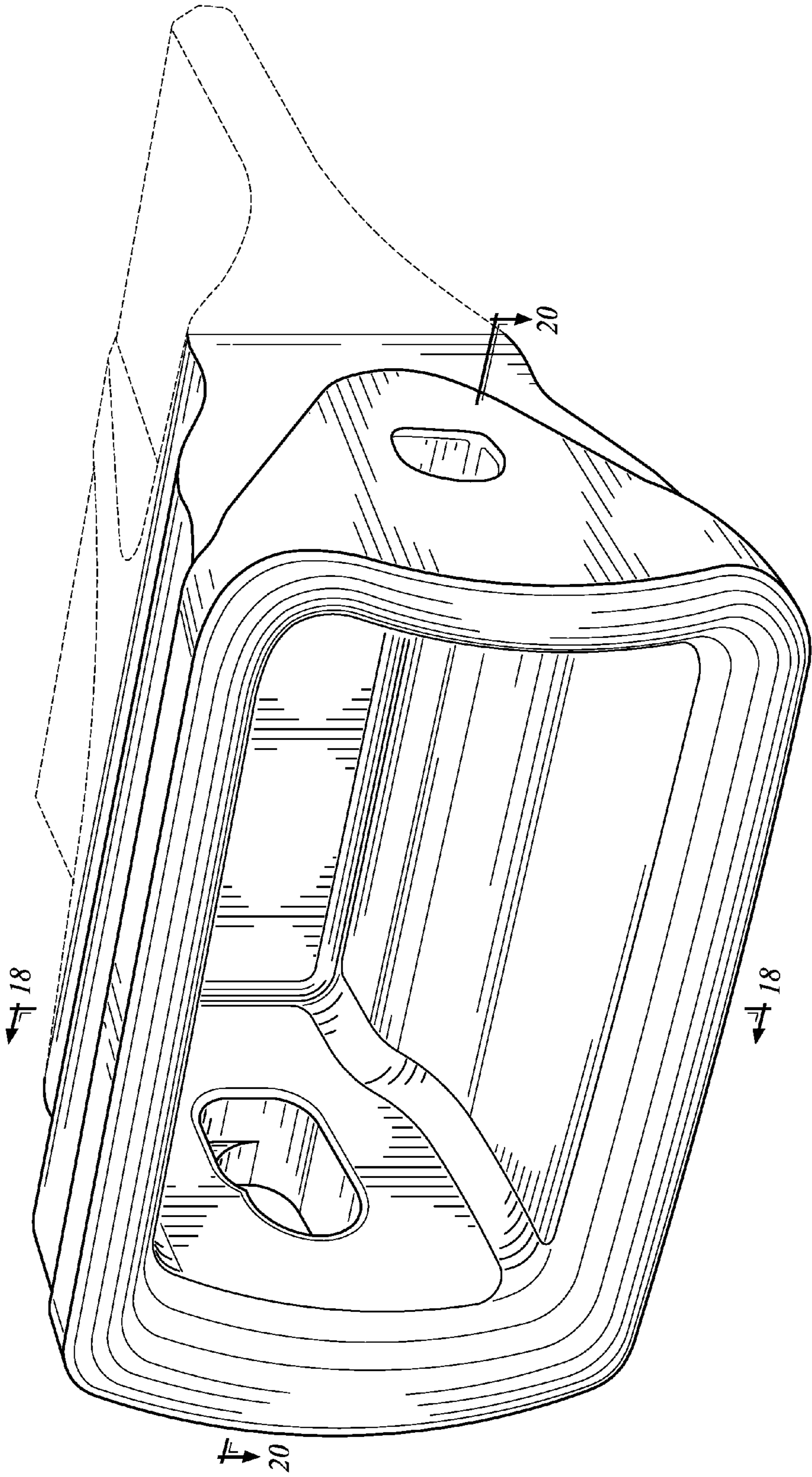

Fig. 15

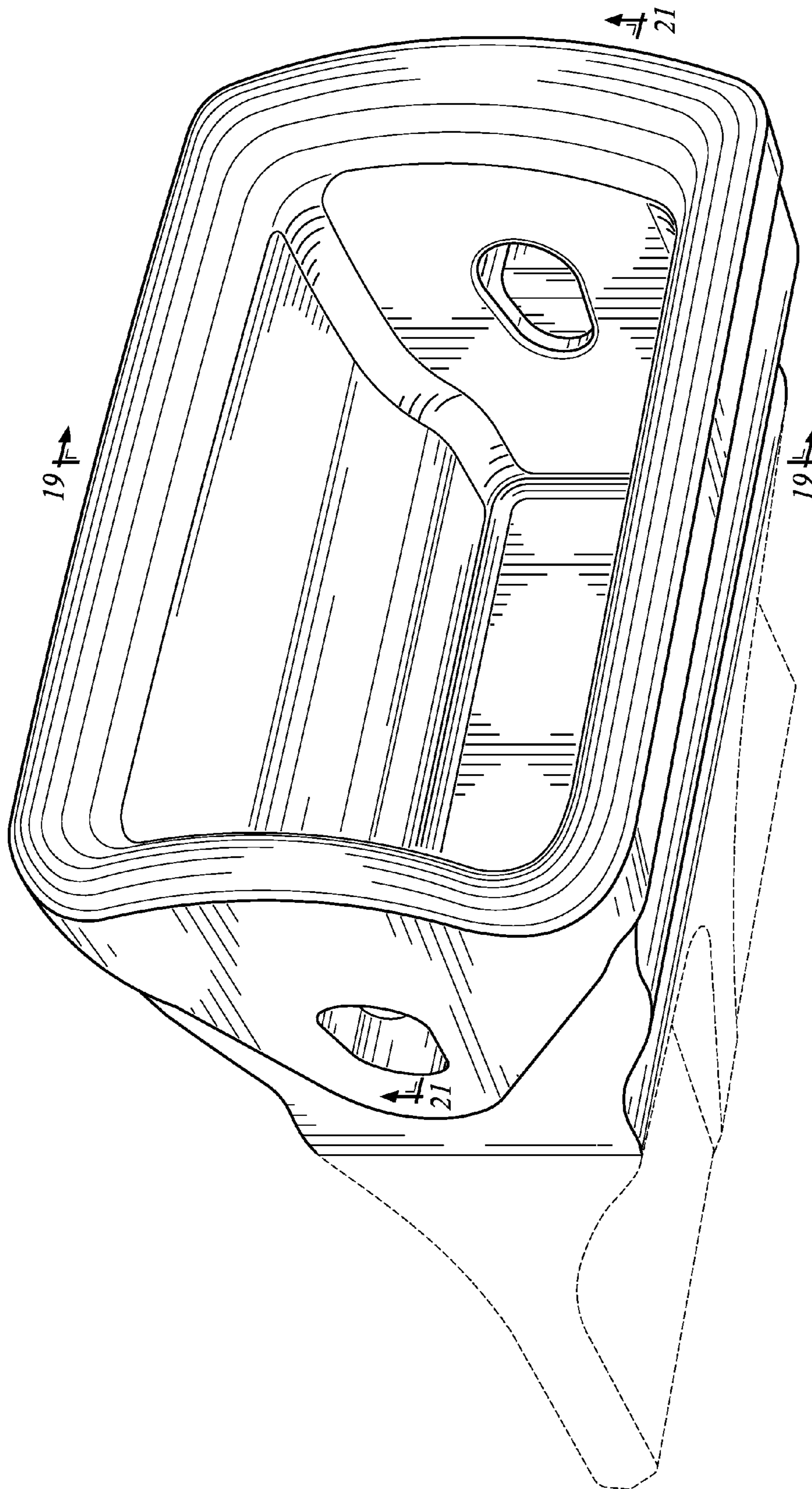

Fig. 16

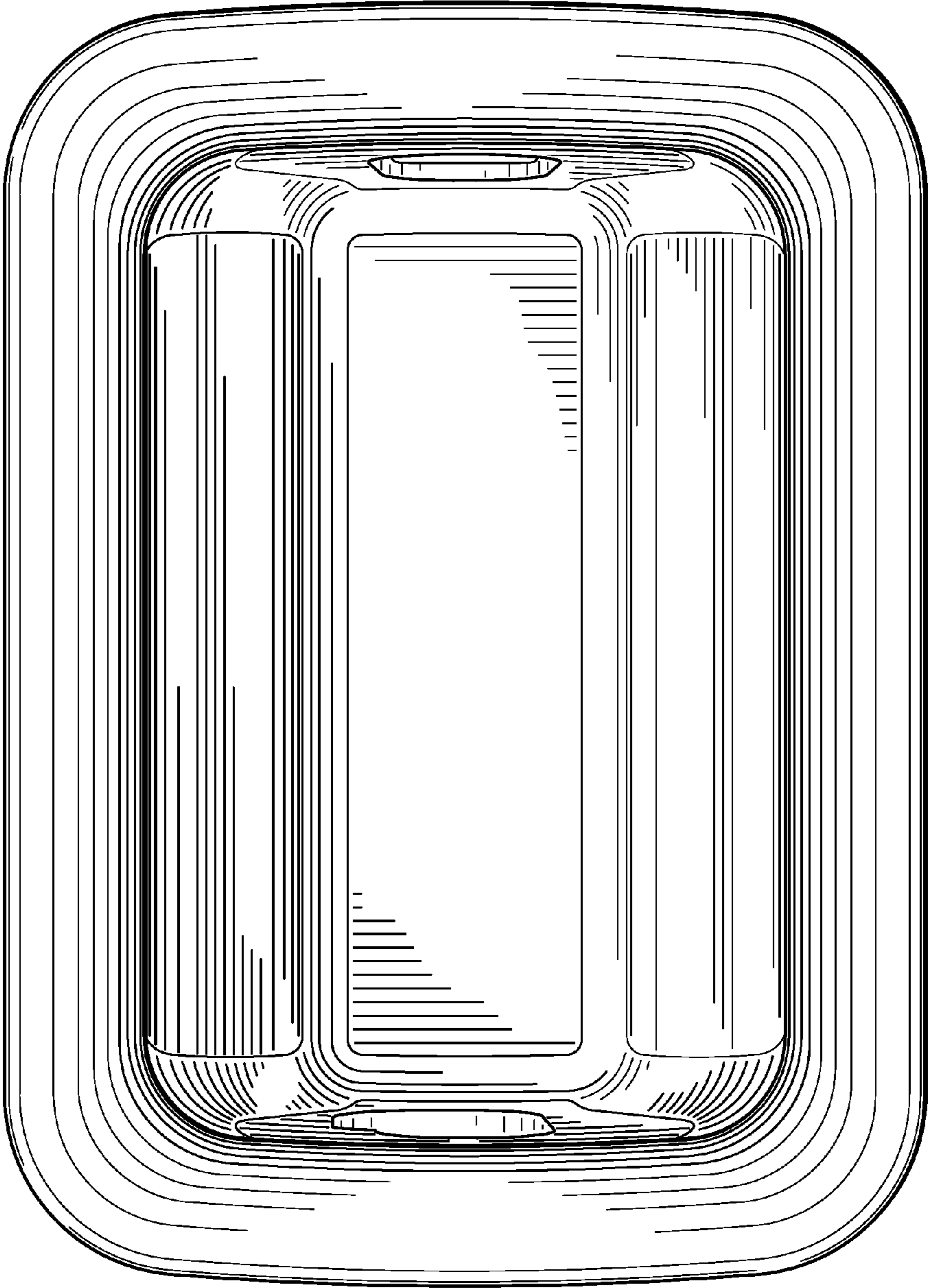

Fig. 17

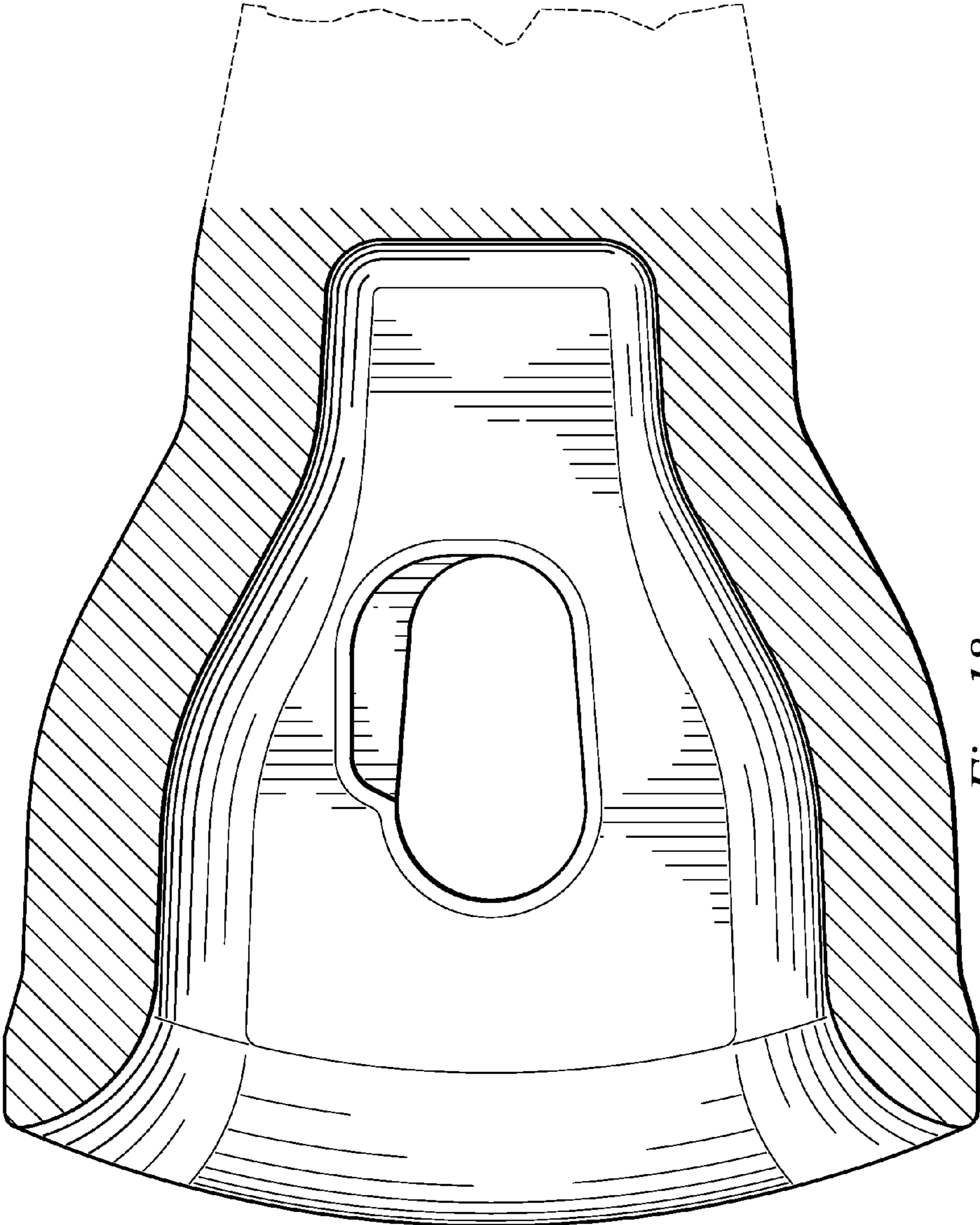

Fig. 18

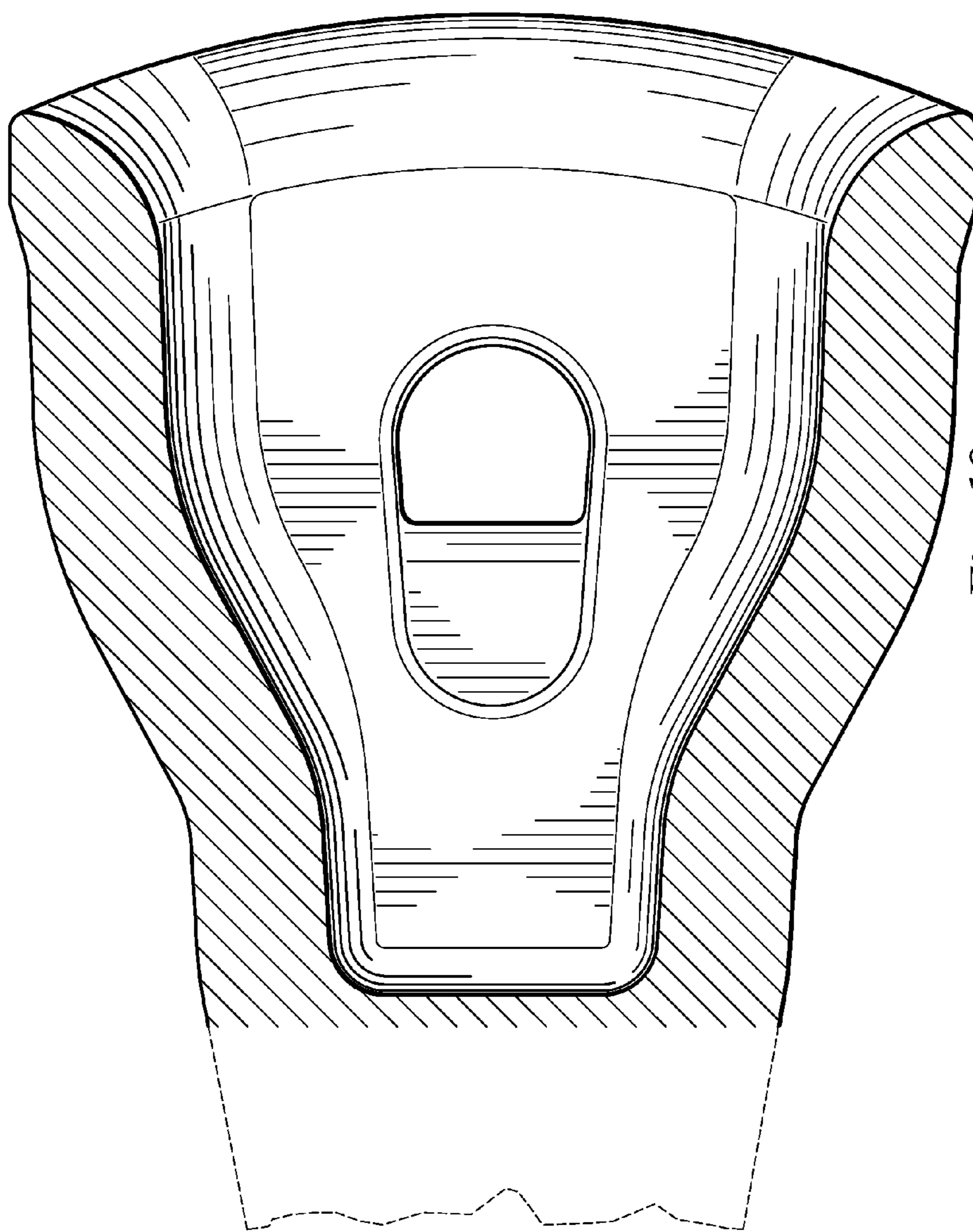

Fig. 19

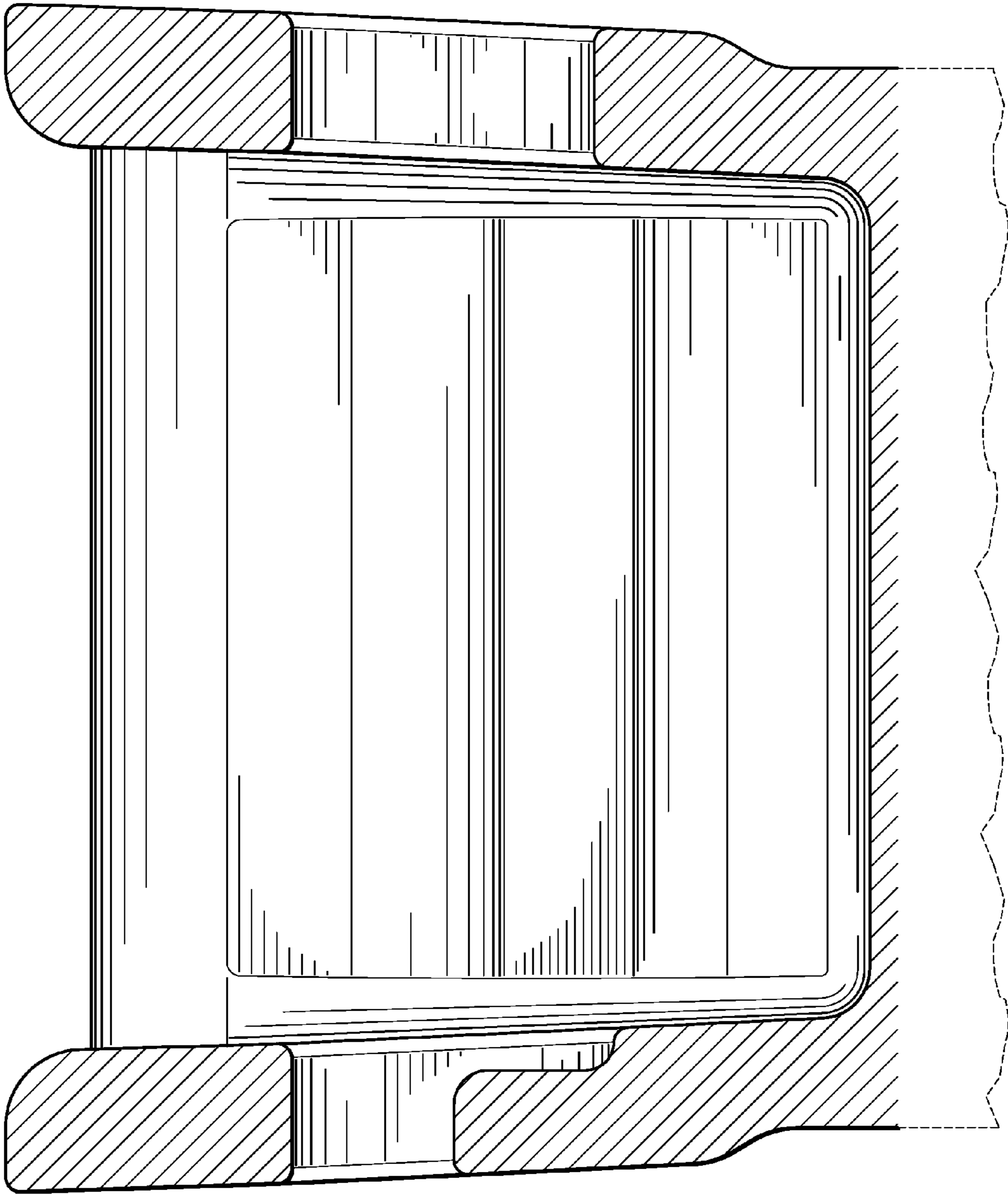

Fig. 20

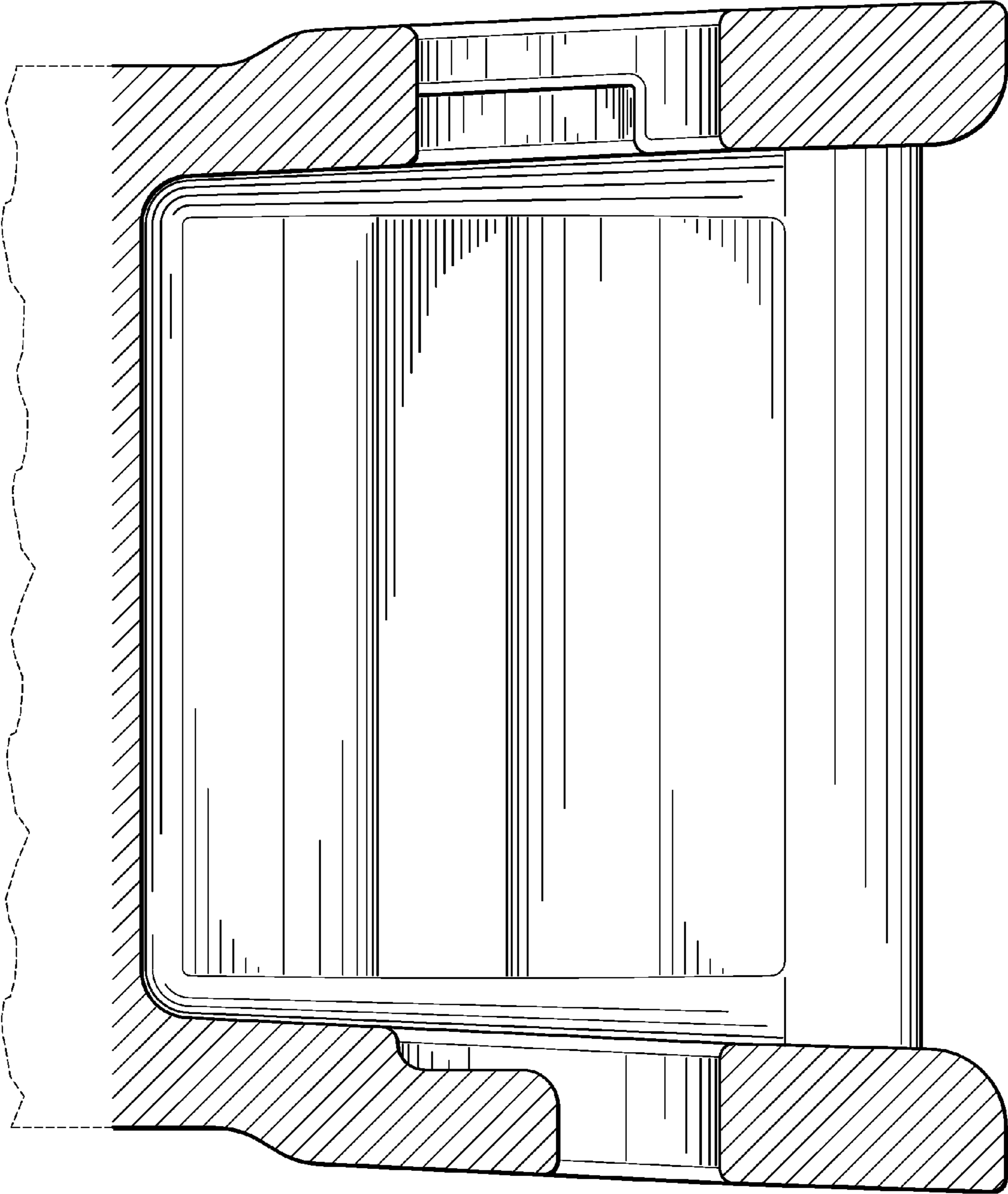

Fig. 21