



US00D614086S

(12) **United States Design Patent**
Wernimont

(10) **Patent No.:** **US D614,086 S**
(45) **Date of Patent:** **** Apr. 20, 2010**

(54) **MOTORCYCLE LOWER LEG AND AXLE COVER WITH A POINTED MOTIF**

(76) Inventor: **Russ Wernimont**, 37100 Applegate Rd.,
Murrieta, CA (US) 92563

(**) Term: **14 Years**

(21) Appl. No.: **29/338,271**

(22) Filed: **Jun. 8, 2009**

(51) **LOC (9) Cl.** **12-11**

(52) **U.S. Cl.** **D12/126**

(58) **Field of Classification Search** D12/110,
D12/114, 126, 184-186, 159-161, 203-213,
D12/118; 296/1.07, 1.08; 280/288.4, 293,
280/304.3, 152.1-152.3, 852, 276, 284, 160.1,
280/157, 279; 180/219, 220; 301/108.1-108.4,
301/37.1, 37.24, 37.371, 37.37, 37.31-37.33,
301/64.1, 65; 74/608, 609

See application file for complete search history.

(56) **References Cited**

U.S. PATENT DOCUMENTS

4,967,867 A * 11/1990 Fuller 180/219
5,152,584 A * 10/1992 Maxwell, Jr. 301/37.107
5,464,277 A * 11/1995 Redd 301/108.4
D407,351 S * 3/1999 Williams et al. D12/126
5,881,835 A * 3/1999 Lucht et al. D12/126
D415,088 S * 10/1999 Schardt D12/204
D419,120 S * 1/2000 Khaladj et al. D12/160

OTHER PUBLICATIONS

2004 J & P Cycles Keeping the World on 2 Wheels ® catalog,
Gladiator Axle Covers by Perse and Series 2000 Billet Axle Caps on

p. 569 and Stainless Fork Tube Caps for Wide Glide ® Forks on p.
598.*

* cited by examiner

Primary Examiner—Philip S Hyder

Assistant Examiner—Linda G. Brooks

(74) *Attorney, Agent, or Firm*—Marcus C. Dawes; Daniel L.
Dawes

(57) **CLAIM**

The ornamental design for a motorcycle lower leg and axle cover with a pointed motif, as shown and described.

DESCRIPTION

FIG. 1 is a bottom three quarter angle view of a motorcycle lower leg and axle cover with a pointed motif showing my new design;

FIG. 2 is a left elevational view thereof;

FIG. 3 is a right elevational view thereof;

FIG. 4 is a rear elevational view thereof;

FIG. 5 is a front elevational view thereof;

FIG. 6 is a top view thereof; and,

FIG. 7 is a bottom view thereof.

The broken lines show portions of the motorcycle lower leg and axle cover with a pointed motif that form no part of the claimed design.

1 Claim, 2 Drawing Sheets

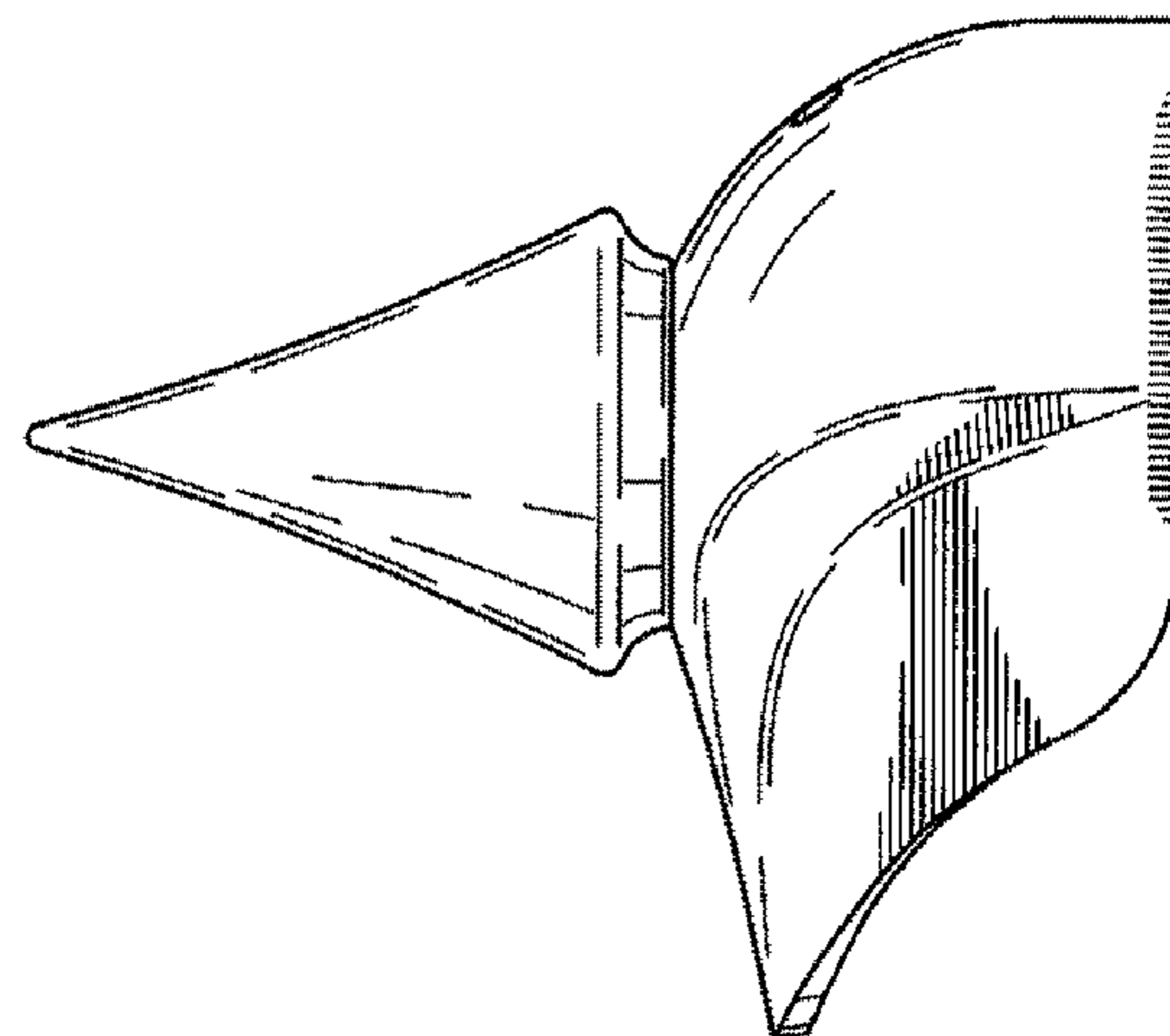
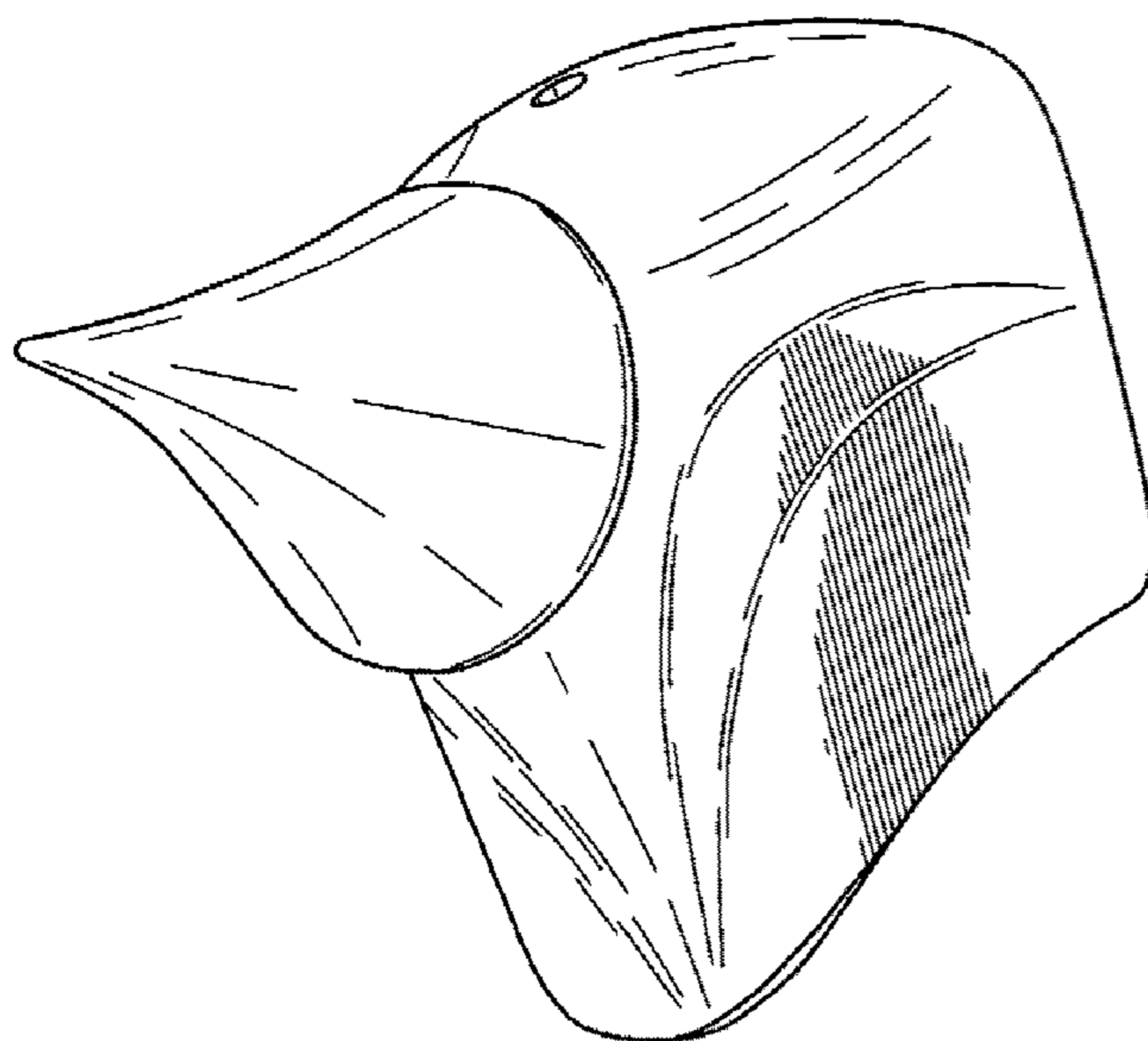

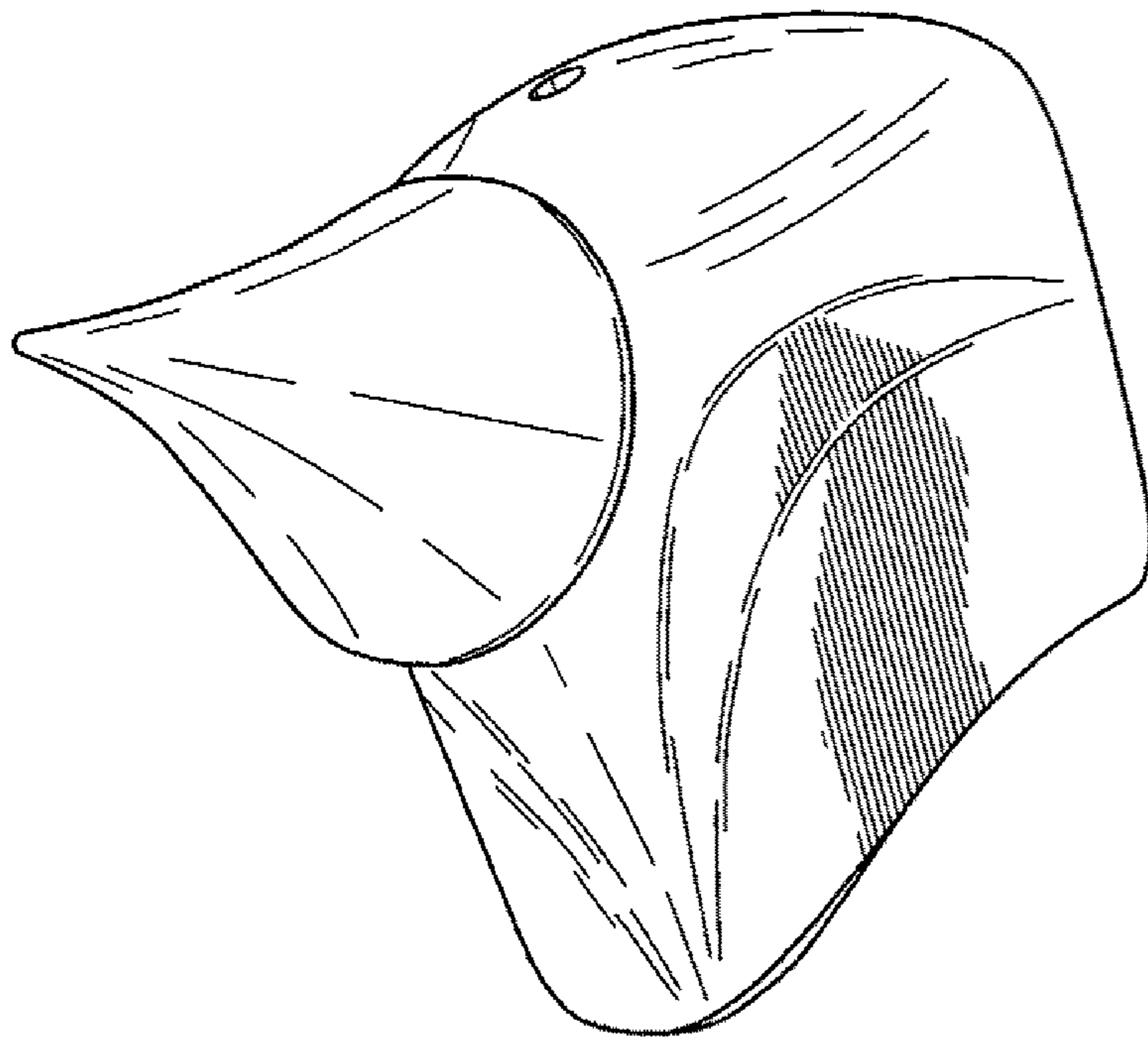

FIG. 1

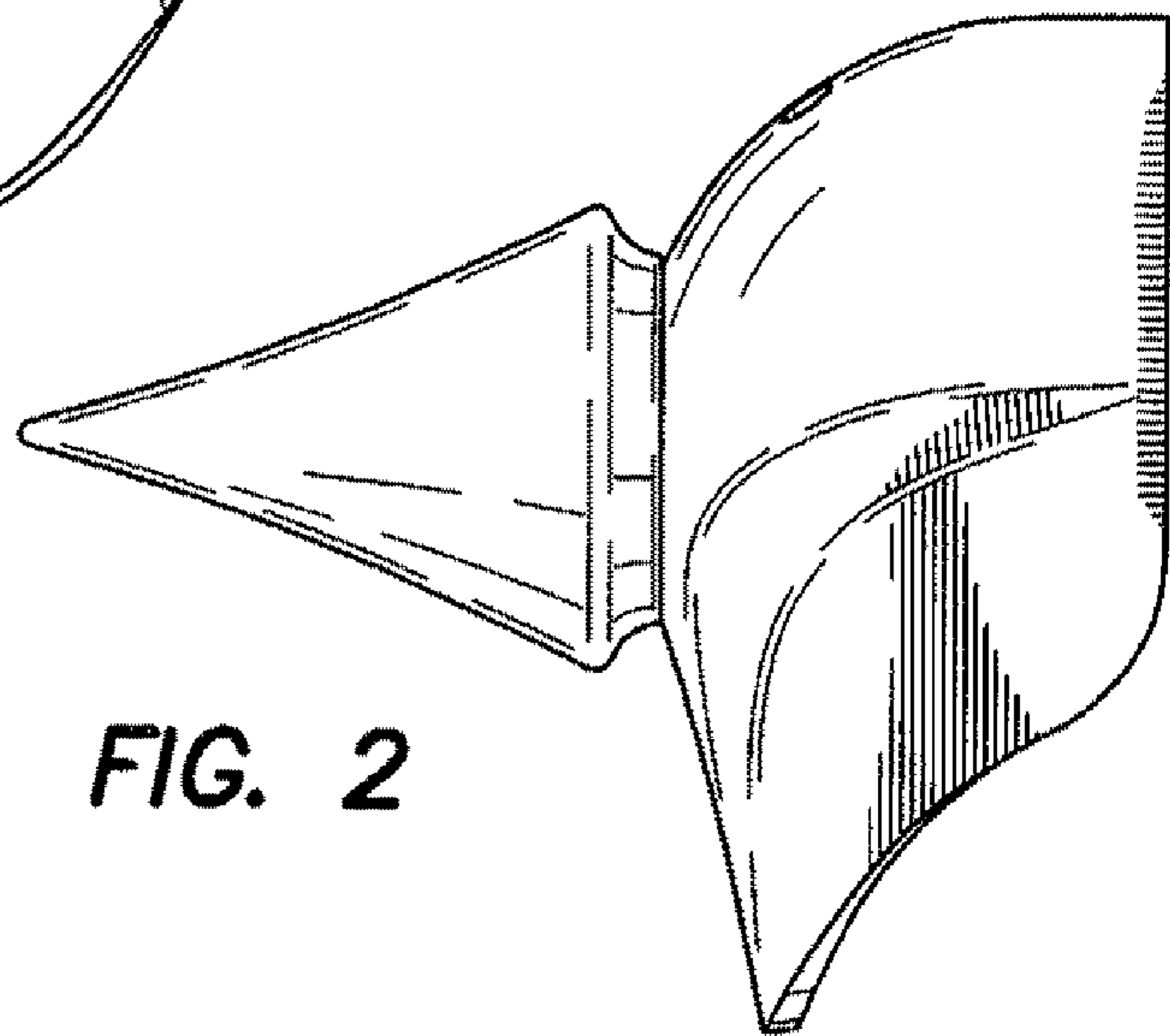

FIG. 2

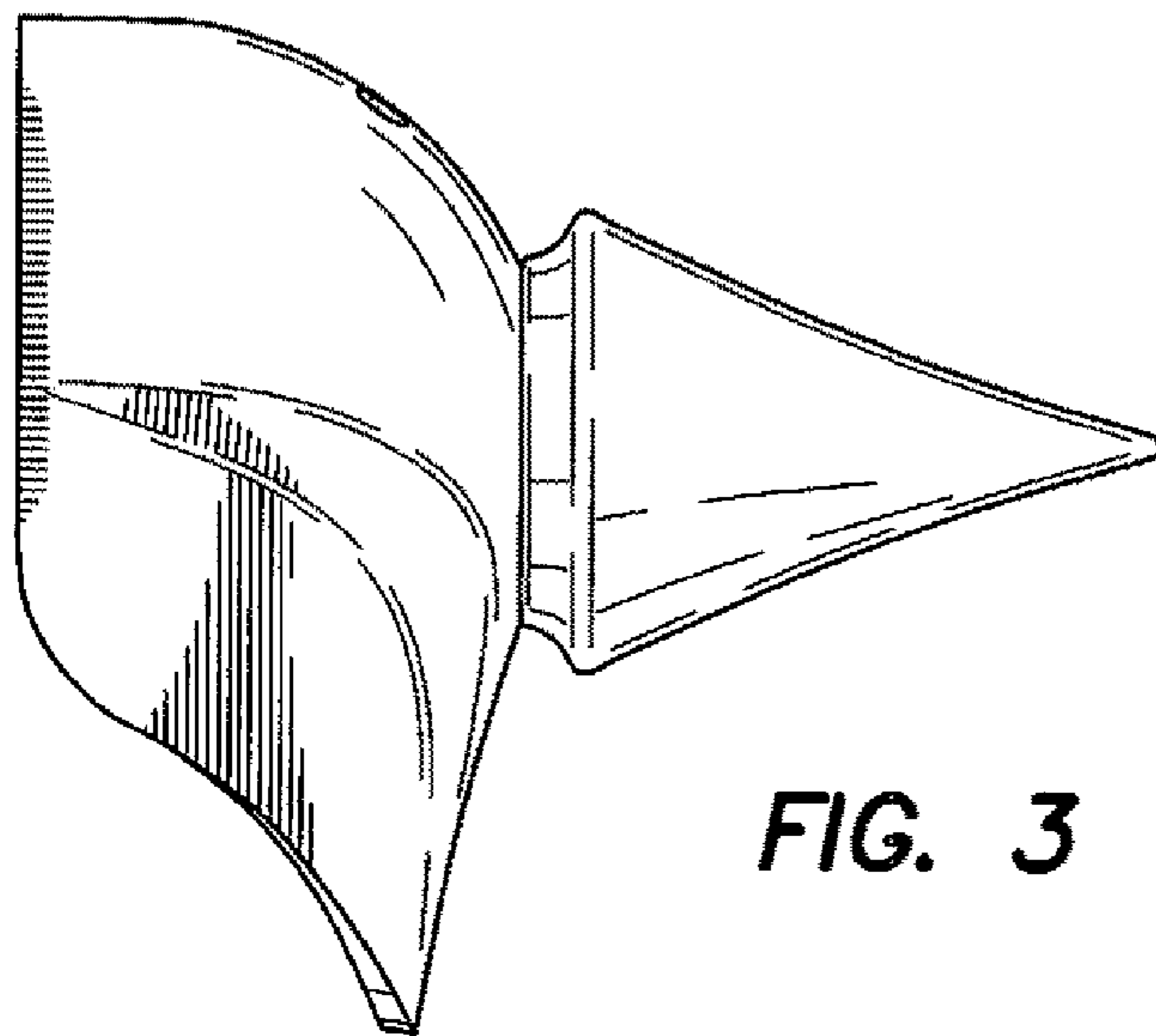

FIG. 3

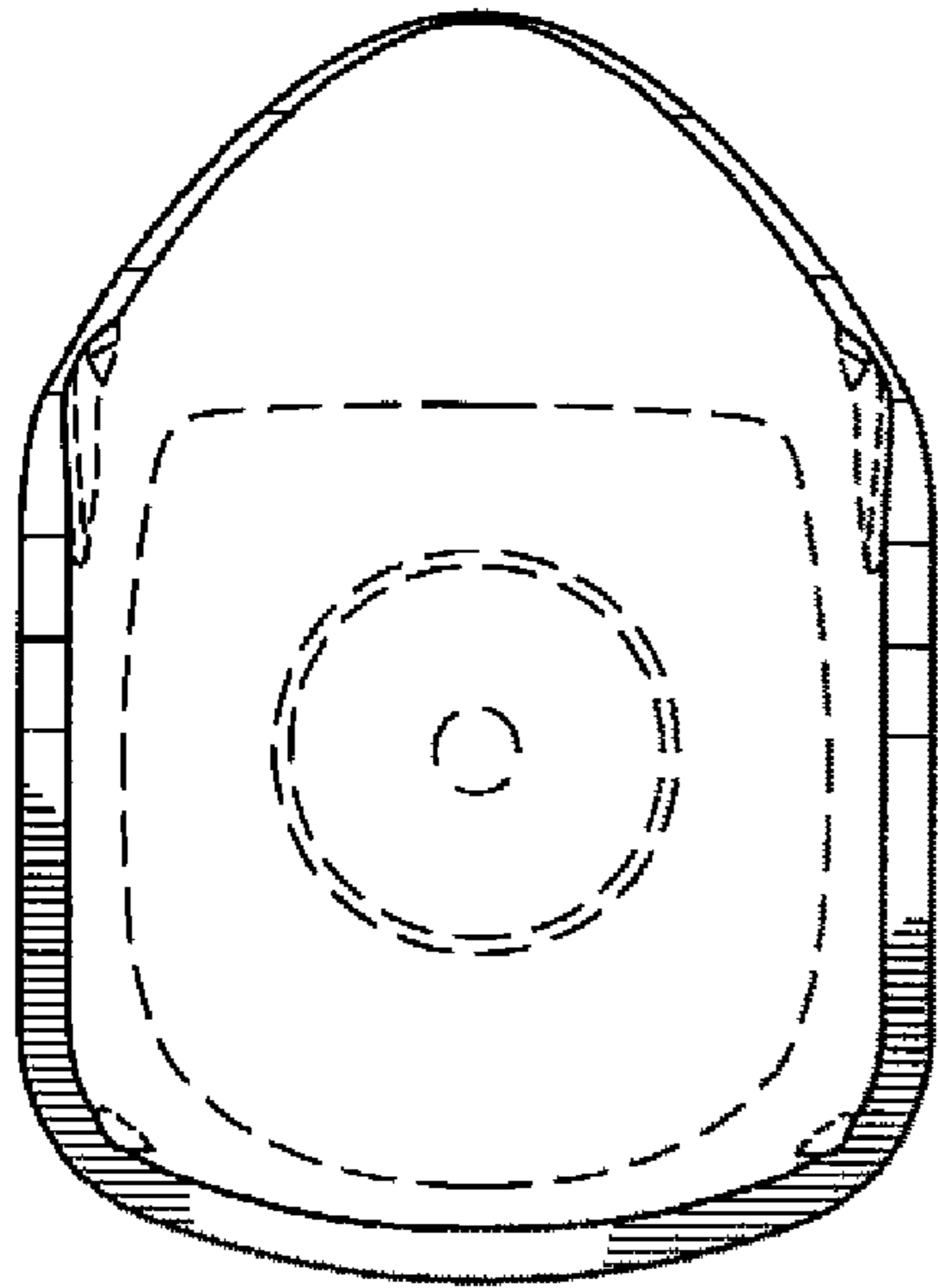

FIG. 4

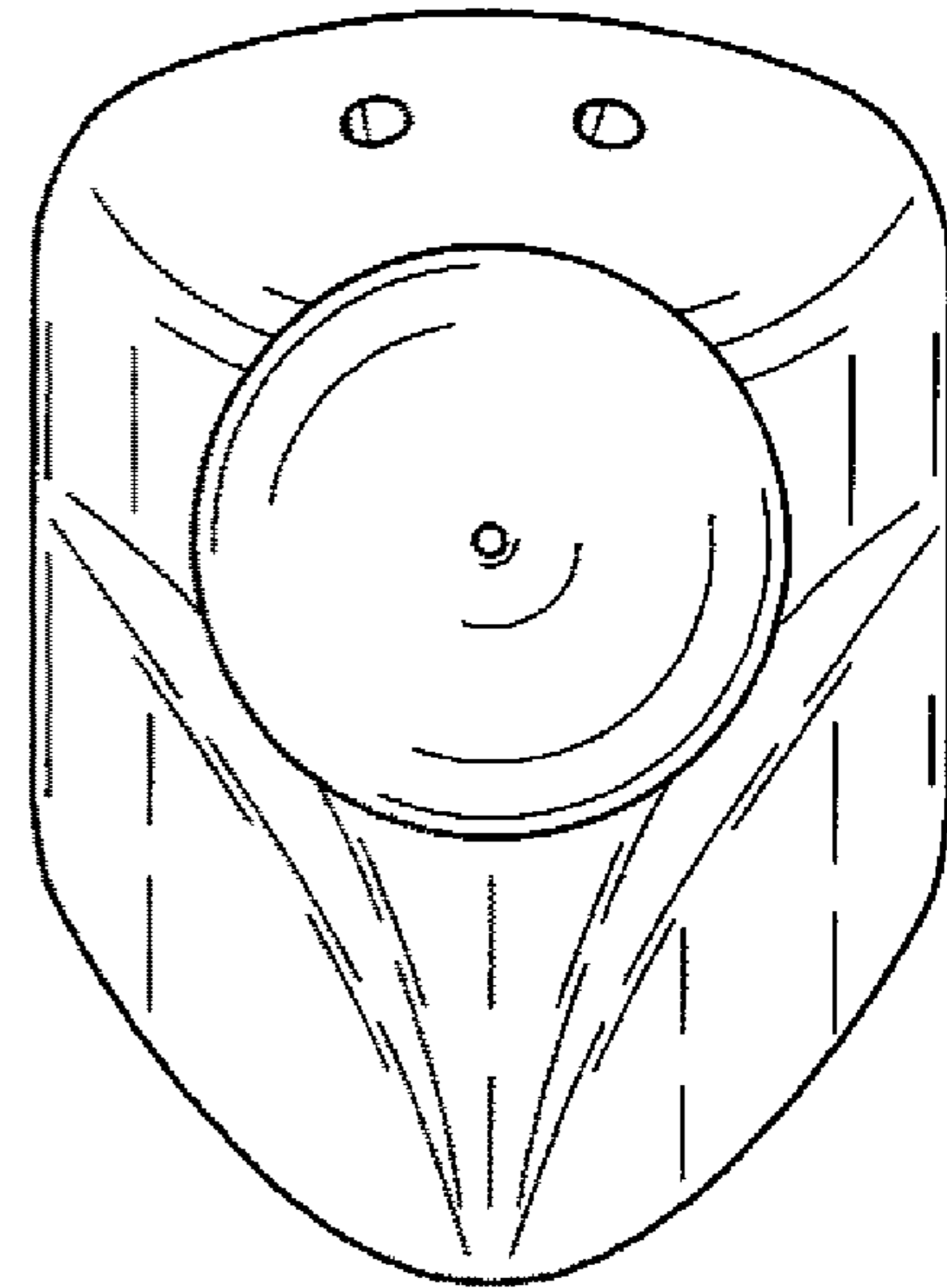

FIG. 5

FIG. 6

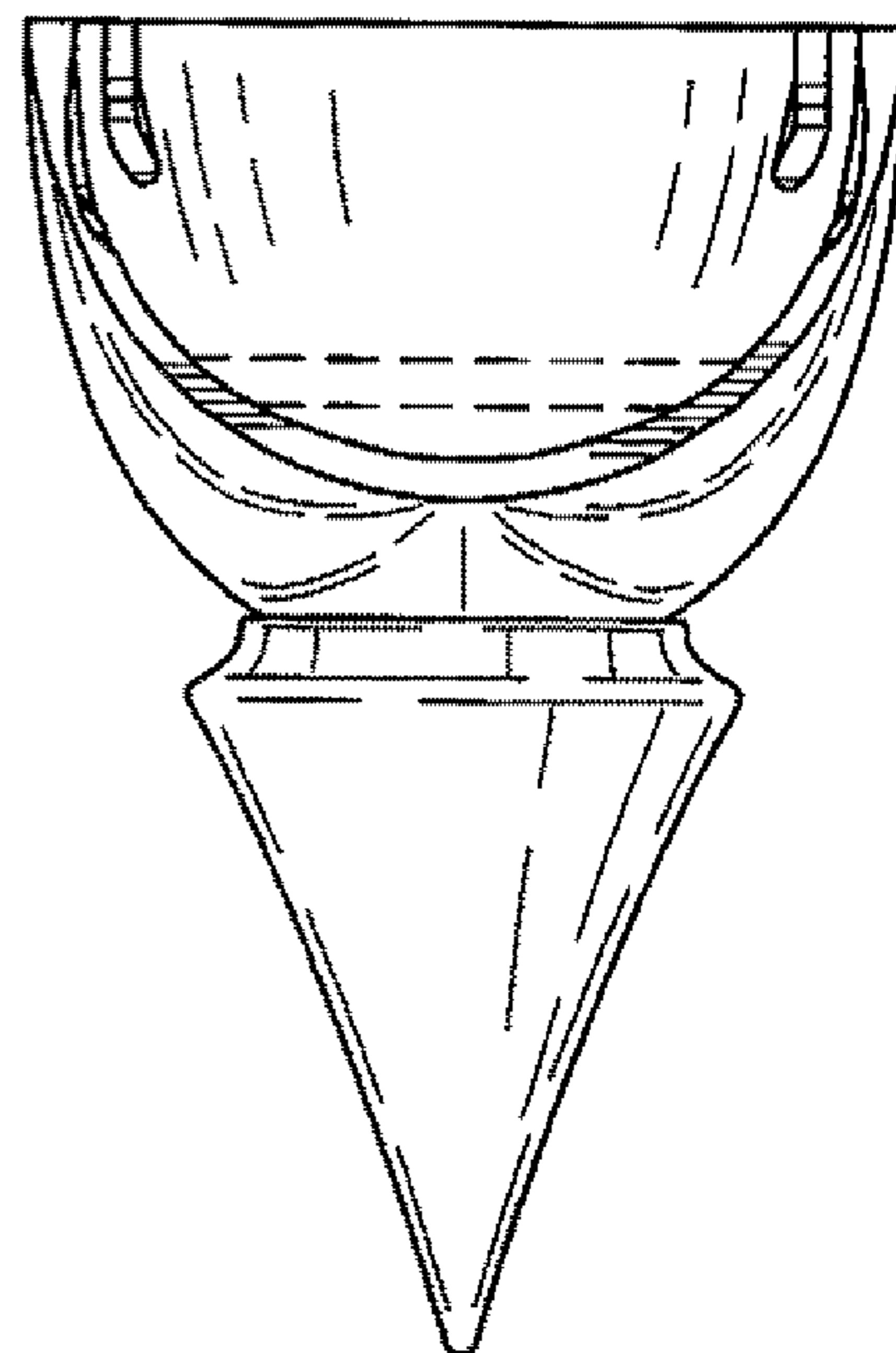
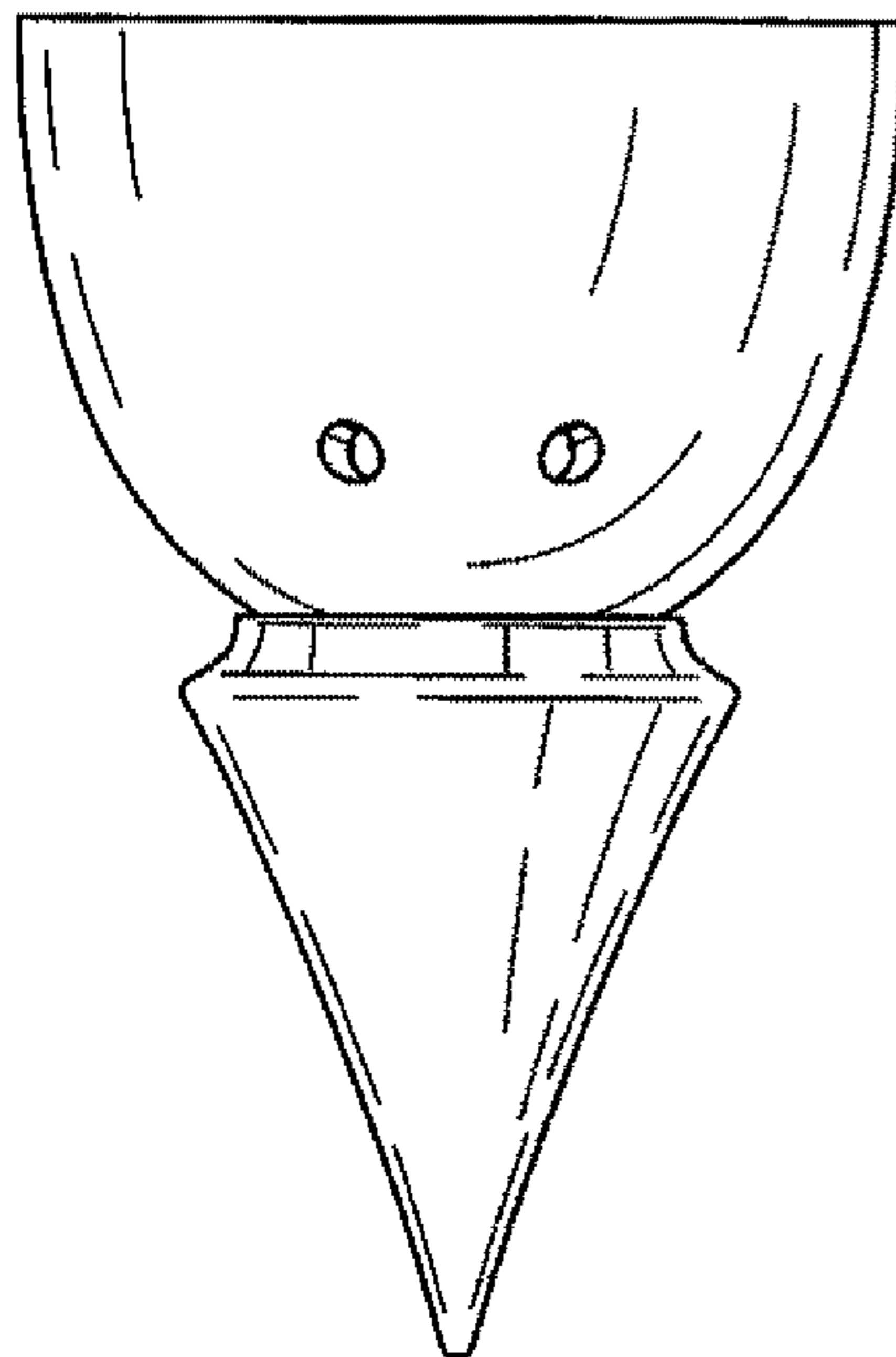

FIG. 7