



US00D613990S

(12) **United States Design Patent**
Baek

(10) **Patent No.:** **US D613,990 S**

(45) **Date of Patent:** **** Apr. 20, 2010**

(54) **MICROWAVE OVEN**

(75) Inventor: **Byung Kook Baek**, Kyunggi-do (KR)

(73) Assignee: **Samsung Electronics Co., Ltd.**, Suwon (KR)

(**) Term: **14 Years**

(21) Appl. No.: **29/342,559**

(22) Filed: **Aug. 27, 2009**

(51) **LOC (9) Cl.** **07-02**

(52) **U.S. Cl.** **D7/351**

(58) **Field of Classification Search** D7/351,
D7/350.1, 350.3, 350.4, 402, 405, 406; 219/678,
219/756-758; 126/19 M, 275 E
See application file for complete search history.

(56) **References Cited**

U.S. PATENT DOCUMENTS

D234,667 S *	4/1975	Linder	D7/351
D297,392 S *	8/1988	Han	D7/351
D302,927 S *	8/1989	Yoshida	D7/351
D303,749 S *	10/1989	Steinkamp	D7/351
D304,411 S *	11/1989	Yoo	D7/351
D304,542 S *	11/1989	Yoo	D7/351

D336,814 S *	6/1993	Brookshire	D7/350.4
D356,006 S *	3/1995	Saimen et al.	D7/351
D521,799 S *	5/2006	Ledingham et al.	D7/350.1
D586,180 S *	2/2009	Pino et al.	D7/405
D602,306 S *	10/2009	Lavy	D7/350.1

* cited by examiner

Primary Examiner—Ruth McInroy

(74) *Attorney, Agent, or Firm*—Ladas and Parry LLP

(57) **CLAIM**

I claim the ornamental design for a microwave oven, and shown and described.

DESCRIPTION

FIG. 1 is a front/right-side/top perspective view of a microwave oven showing our new design;

FIG. 2 is a front elevational view thereof;

FIG. 3 is a rear elevational view thereof;

FIG. 4 is a left-side elevational view thereof;

FIG. 5 is a right-side elevational view thereof;

FIG. 6 is a top plan view thereof; and,

FIG. 7 is a bottom plan view thereof.

1 Claim, 4 Drawing Sheets

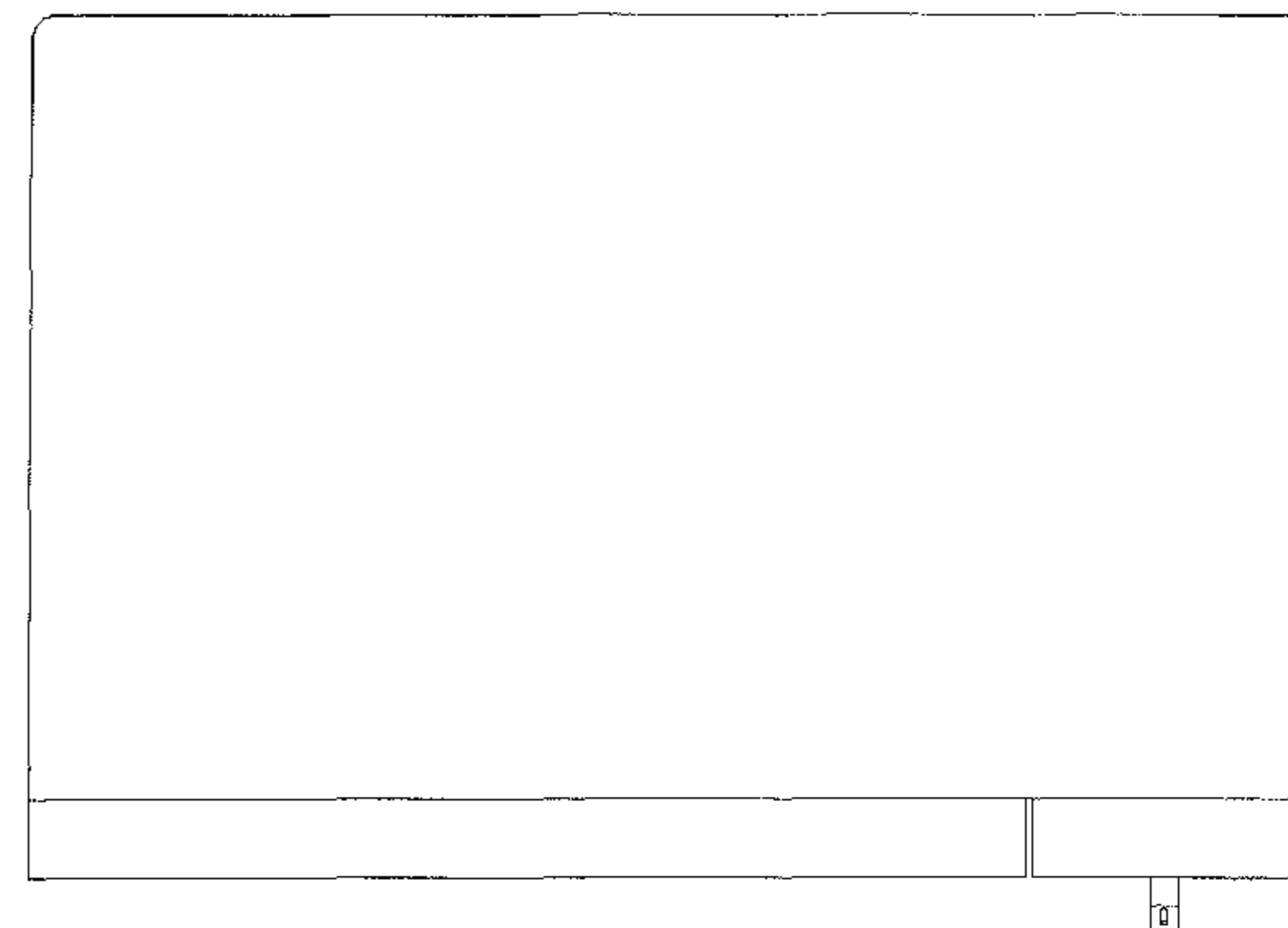
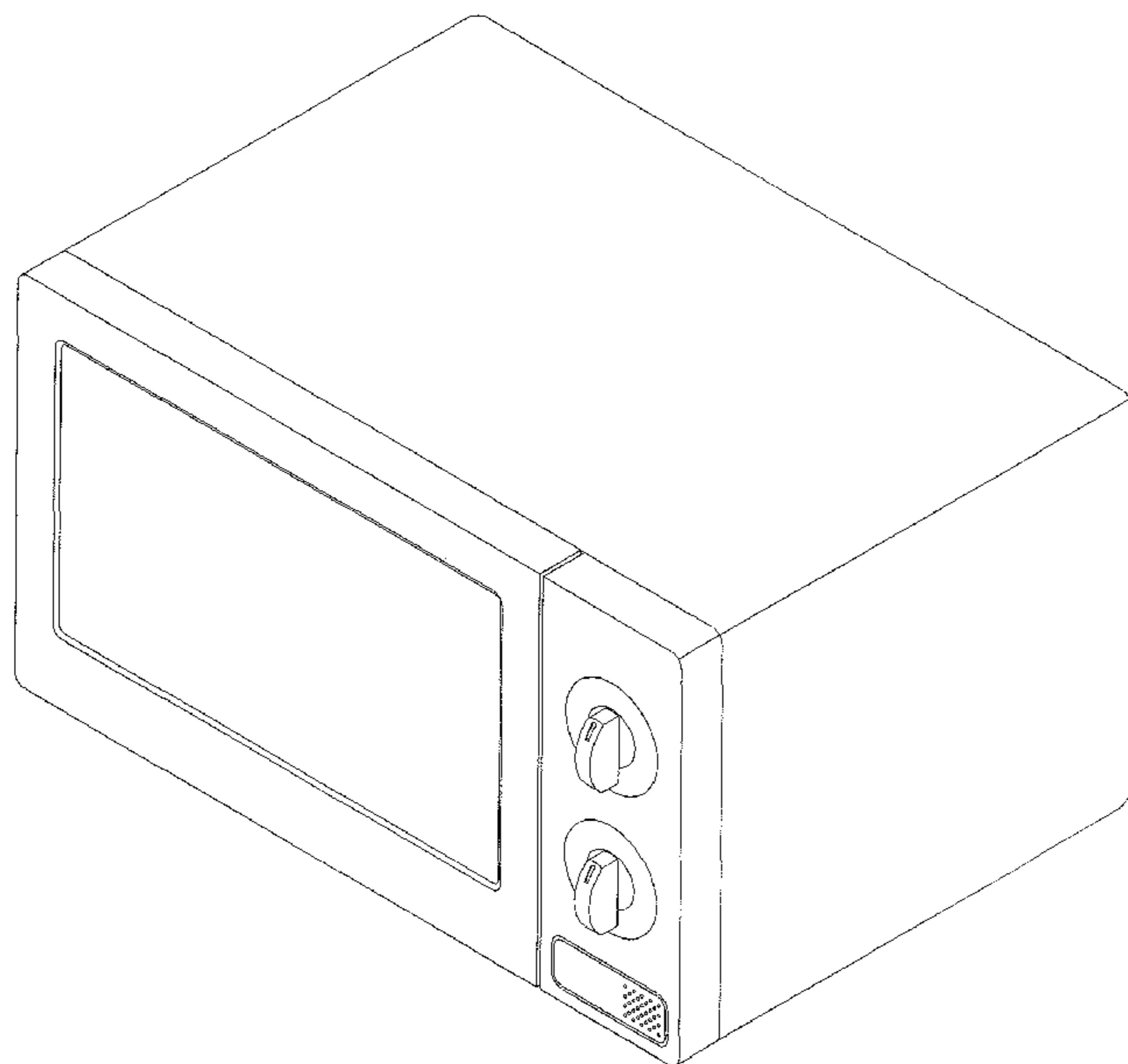

FIG. 1

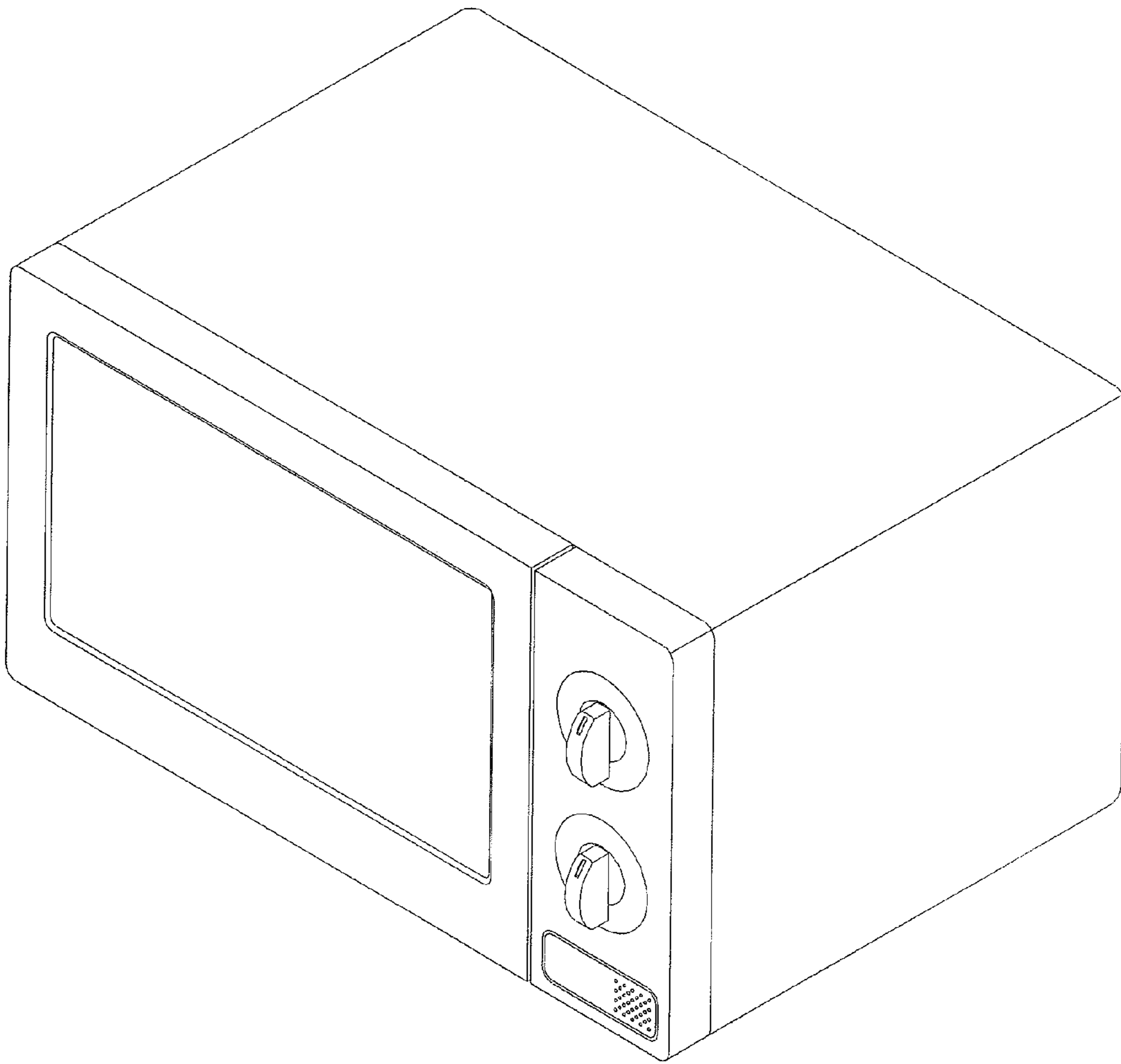

FIG. 2

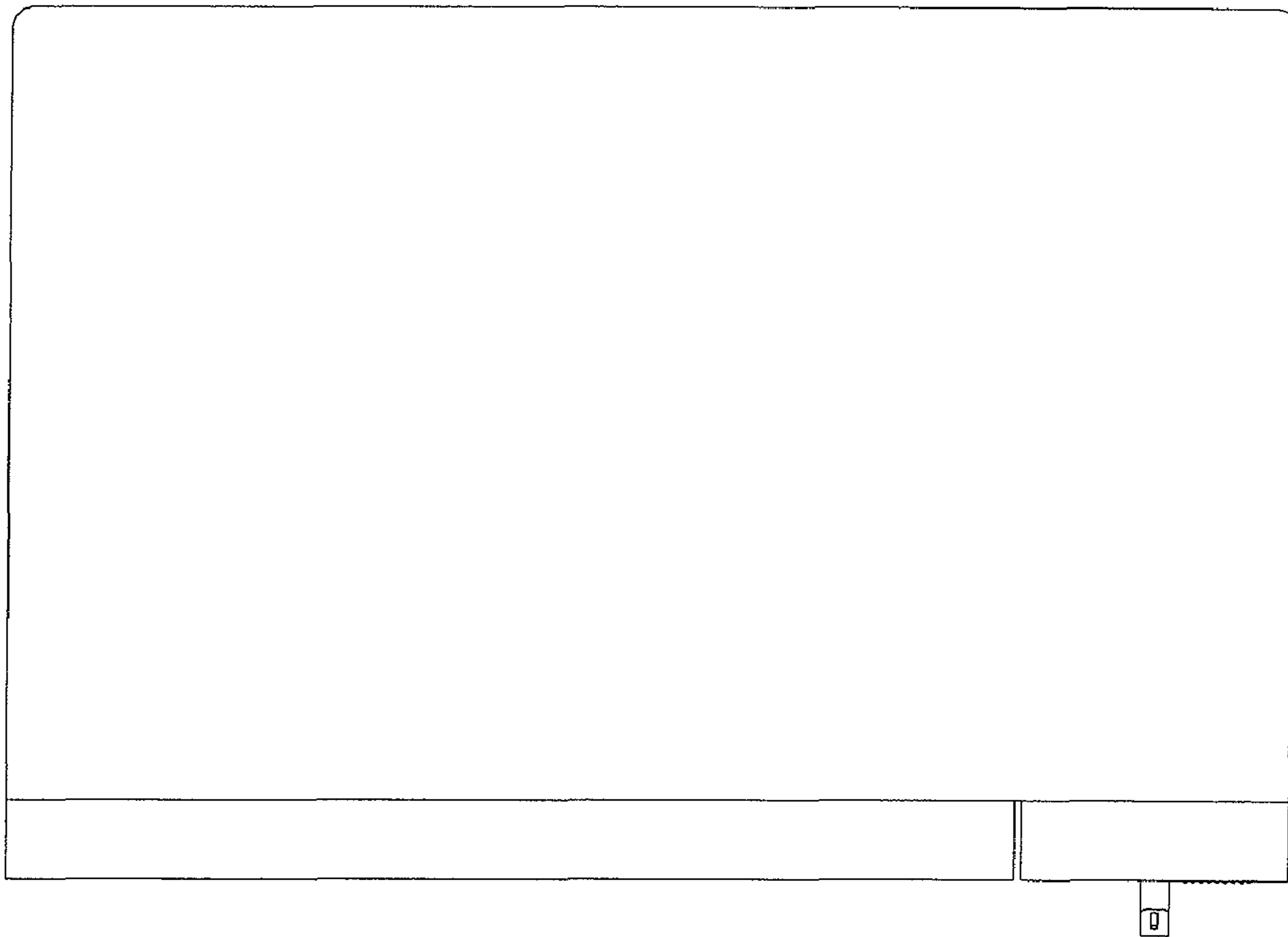

FIG. 3

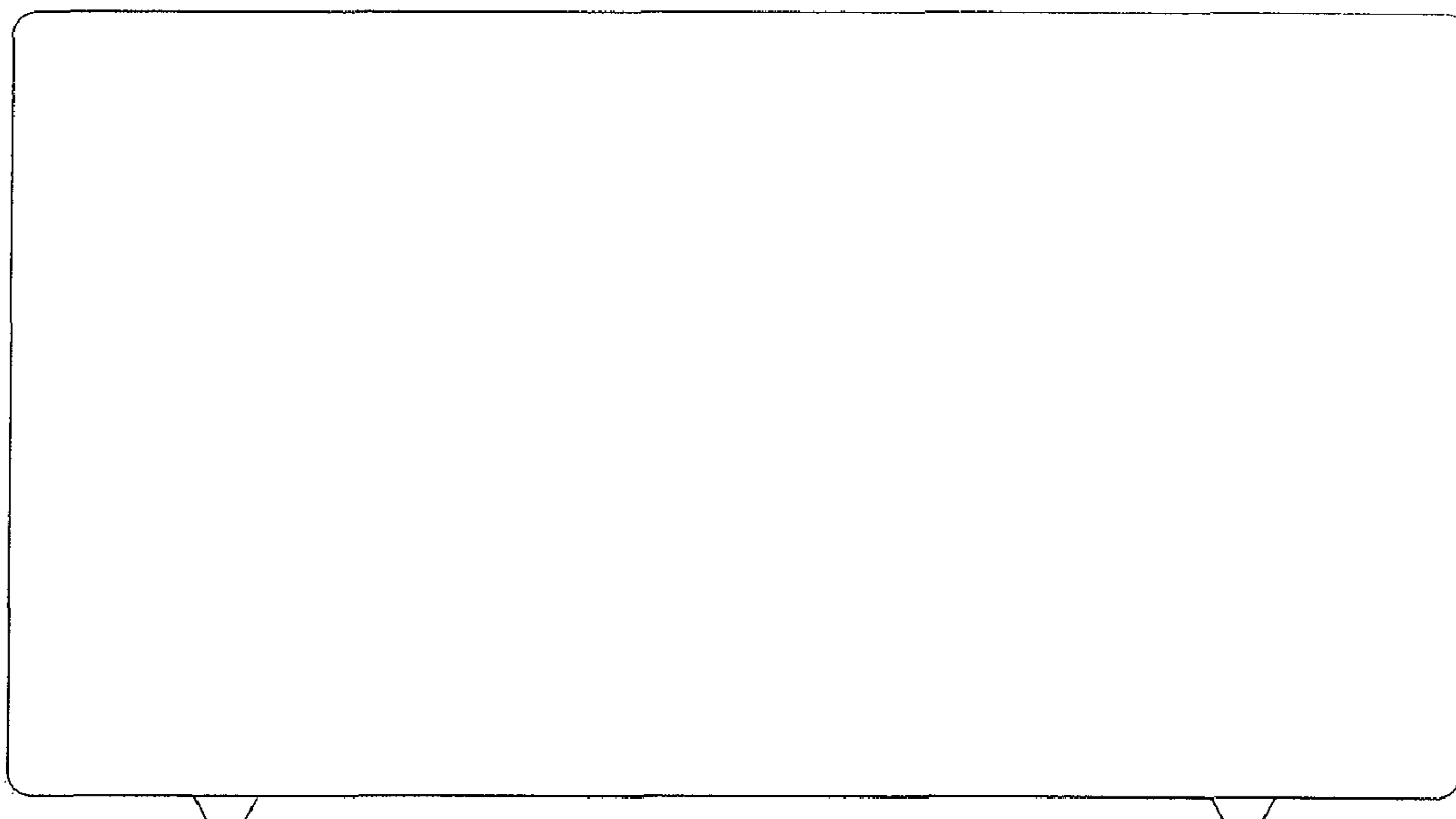

FIG. 4

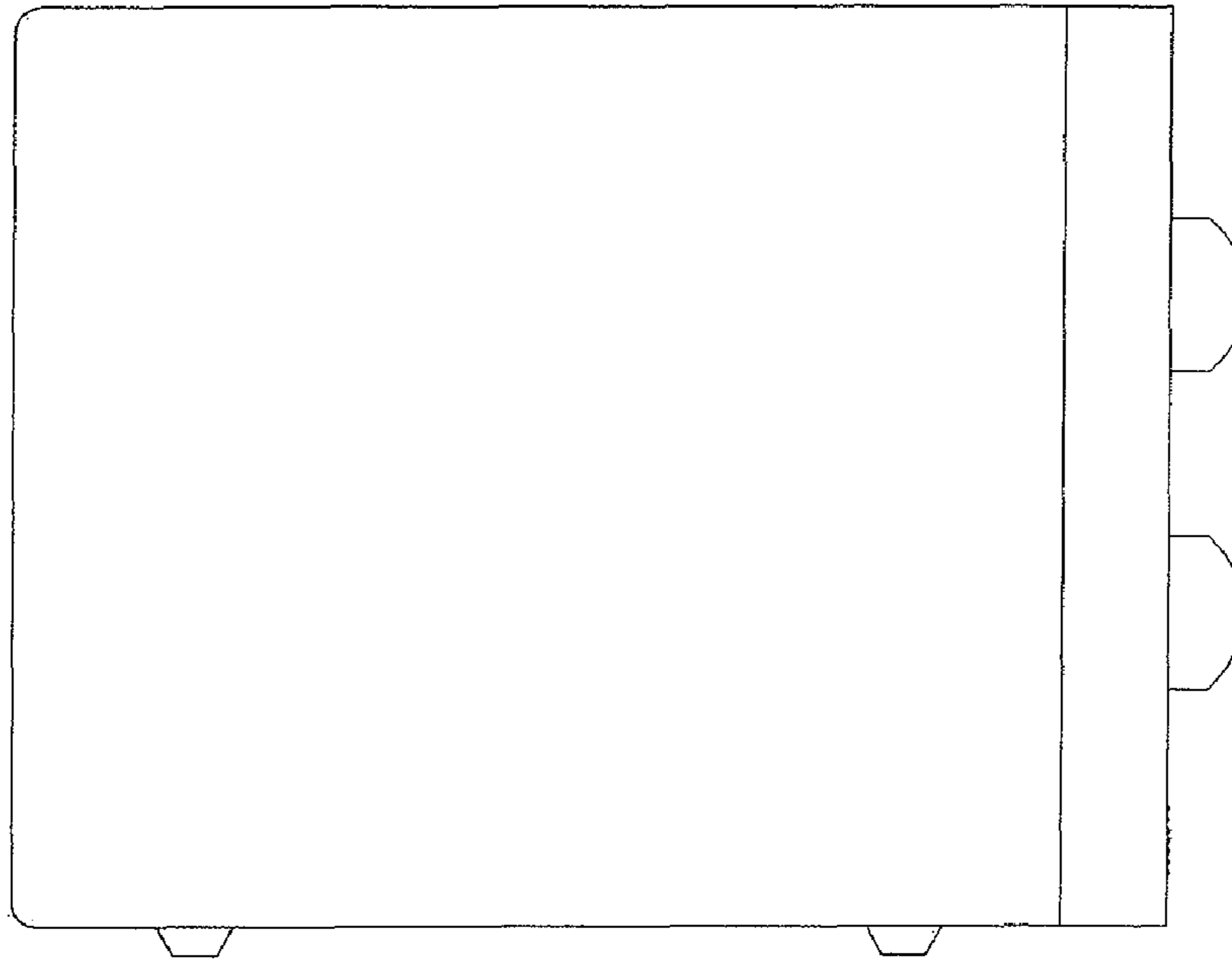

FIG. 5

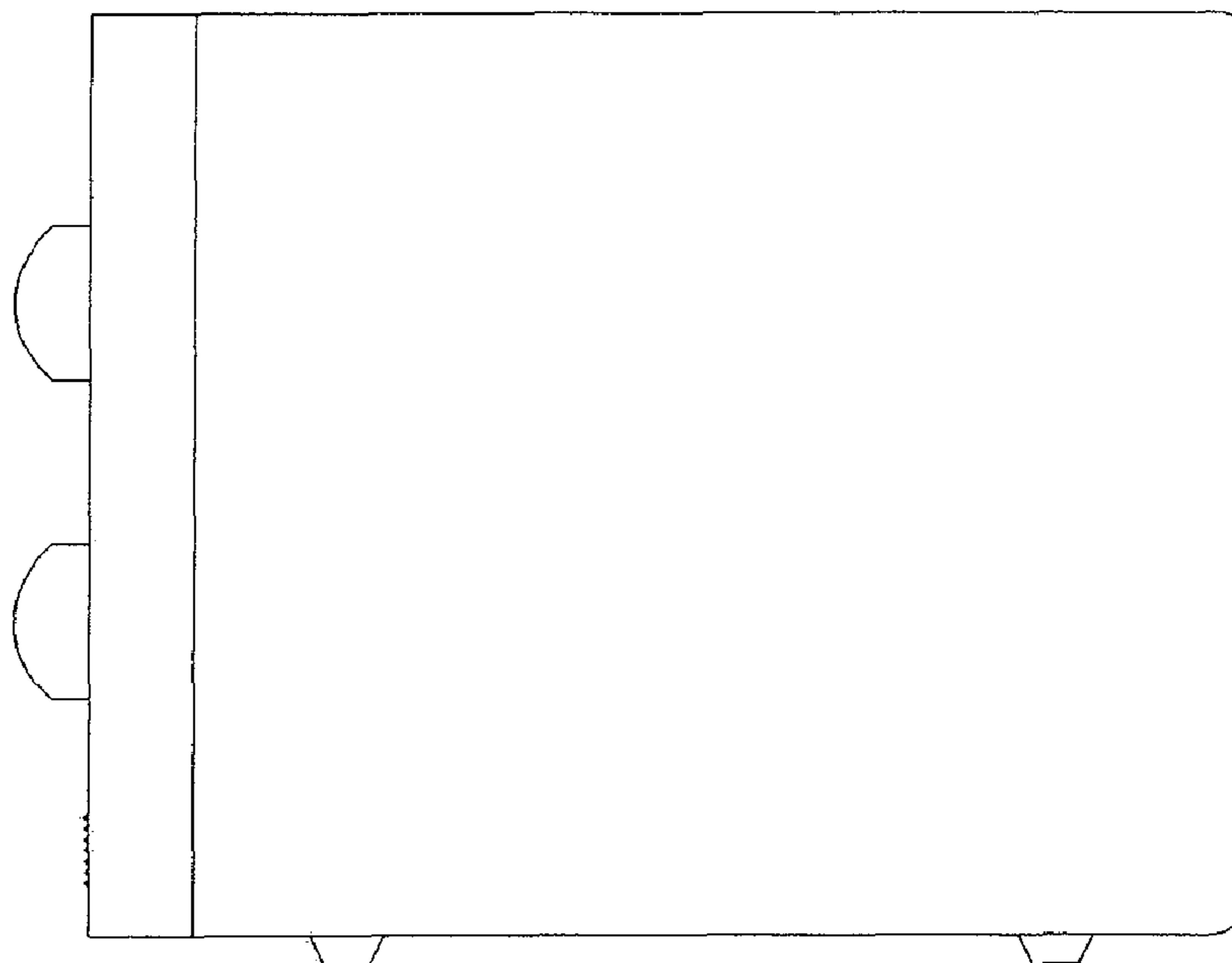

FIG. 6

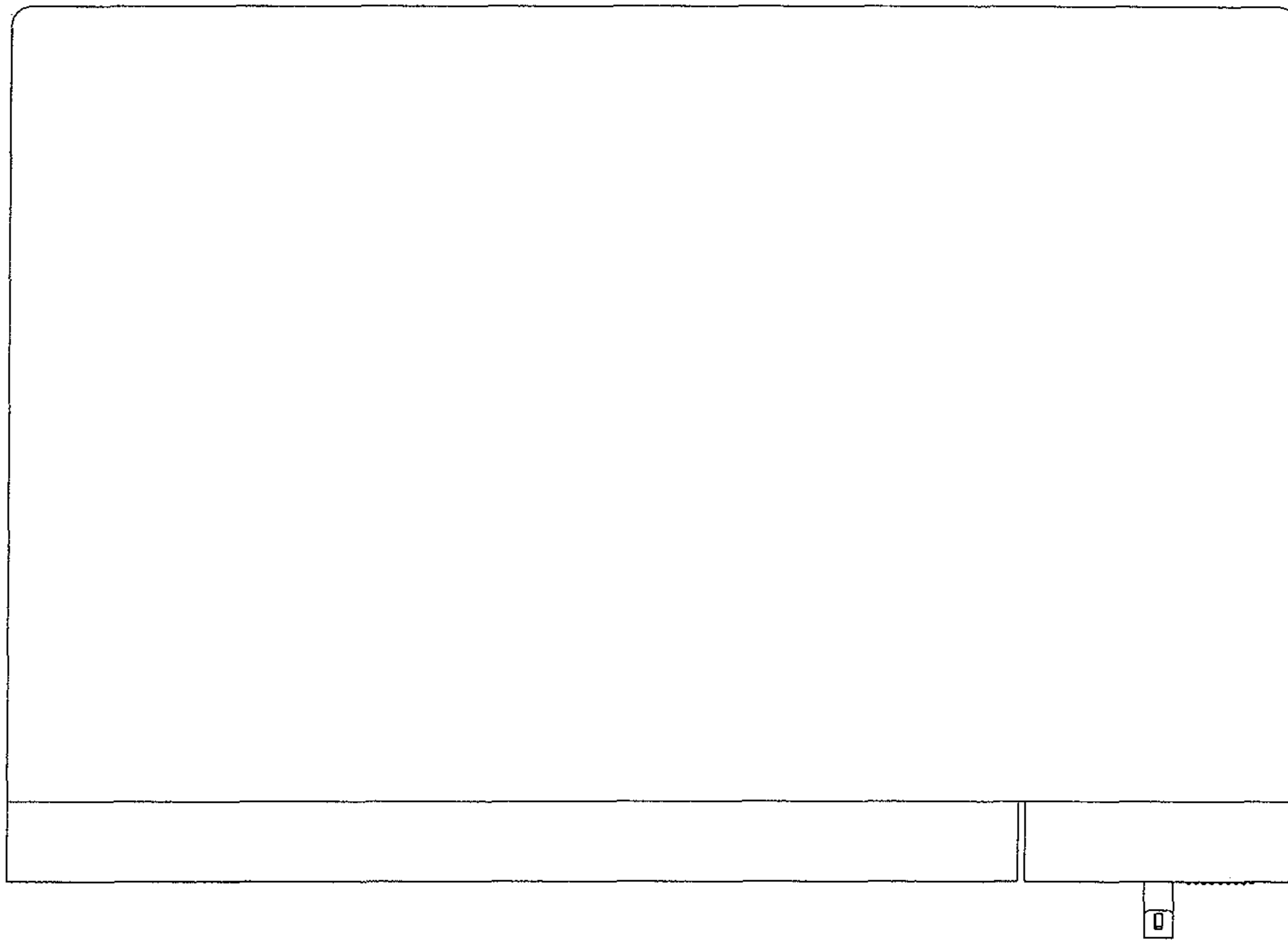

FIG. 7

