



US00D613611S

(12) **United States Design Patent**  
**Wu**

(10) **Patent No.:** **US D613,611 S**  
(45) **Date of Patent:** **\*\* Apr. 13, 2010**

(54) **BOTTLE**

(76) Inventor: **Jiang-Her Wu**, No. 10, Alley 2, Lane  
121, Longsiao St., Gueishan Township,  
Taoyuan County (TW) 333

(\*\*) Term: **14 Years**

(21) Appl. No.: **29/329,530**

(22) Filed: **Dec. 17, 2008**

(51) **LOC (9) Cl.** ..... **09-01**

(52) **U.S. Cl.** ..... **D9/538; D9/554; D9/555;**  
D9/557

(58) **Field of Classification Search** ..... D9/502,  
D9/516, 690-692, 537-540, 545-546, 549,  
D9/553-558, 566-568, 570; 215/381-385;  
220/660, 669, 675; D24/197

See application file for complete search history.

(56) **References Cited**

**U.S. PATENT DOCUMENTS**

D67,215 S *	5/1925	Lents	.....	D9/555
D96,511 S *	8/1935	Sakier	.....	D9/563
D117,302 S *	10/1939	Busiel	.....	D9/538
D155,134 S *	9/1949	Dykstra	.....	D9/568
D179,022 S *	10/1956	Menefee, Jr.	.....	D9/502
D182,734 S *	5/1958	Luxardo	.....	D9/555 X
D183,127 S *	7/1958	Johnson	.....	D9/503
D187,302 S *	2/1960	Campbell	.....	D9/502
D190,058 S *	4/1961	Koenigsberg	.....	D9/502
D192,827 S *	5/1962	Denhoff et al.	.....	D9/541 X
D193,688 S *	9/1962	Sterges	.....	D9/502
D212,320 S *	10/1968	Hills	.....	D9/502

D212,321 S *	10/1968	Hills	.....	D9/502
D219,098 S *	11/1970	Hills	.....	D9/502
D238,930 S *	2/1976	Dadnum et al.	.....	D9/545
D314,136 S *	1/1991	Malvoisin	.....	D9/541 X
D538,169 S *	3/2007	Nosselbock	.....	D9/555 X
D549,103 S *	8/2007	Kuethe et al.	.....	D9/538
D574,244 S *	8/2008	Lin	.....	D9/554 X

\* cited by examiner

*Primary Examiner*—Carol Rademaker

(74) *Attorney, Agent, or Firm*—Chun-Ming Shih

(57) **CLAIM**

The ornamental design for a bottle, as shown and described.

**DESCRIPTION**

FIG. 1 is a top, front, right side perspective view of a bottle showing my new design;

FIG. 2 is a front elevational view thereof, shown with an enlarged detail of the horizontal band shown on the lower sidewall edge;

FIG. 3 is a rear elevational view thereof;

FIG. 4 is a left side elevational view thereof;

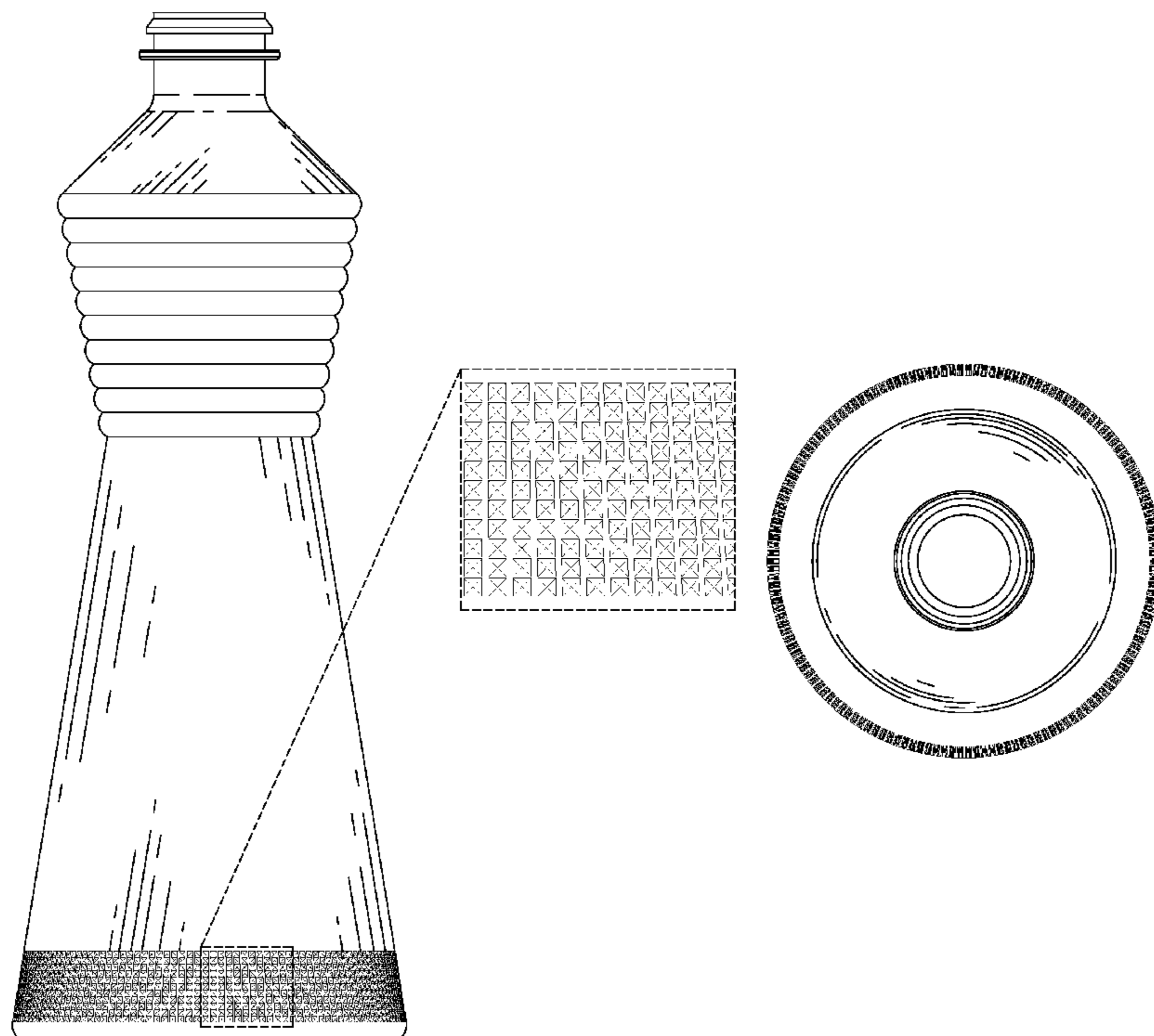
FIG. 5 is a right side elevational view thereof;

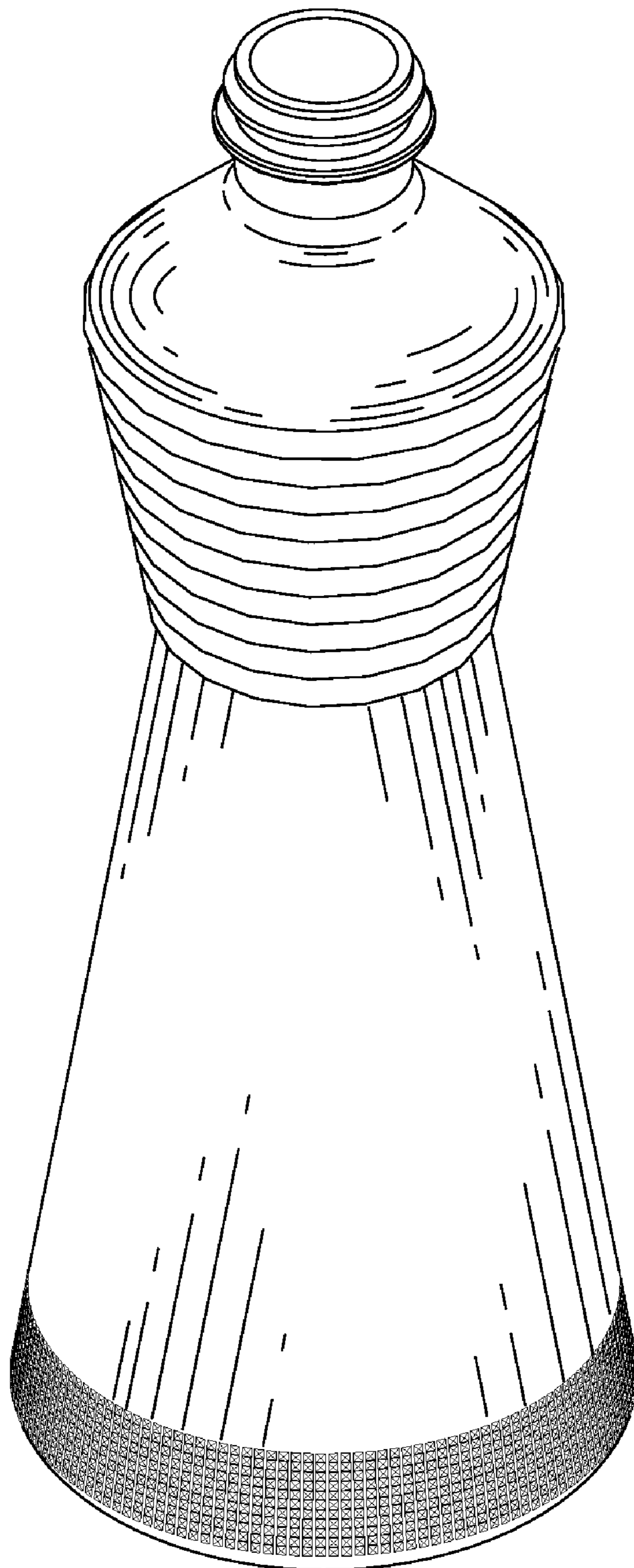
FIG. 6 is a top plan view thereof; and,

FIG. 7 is a bottom plan view thereof.

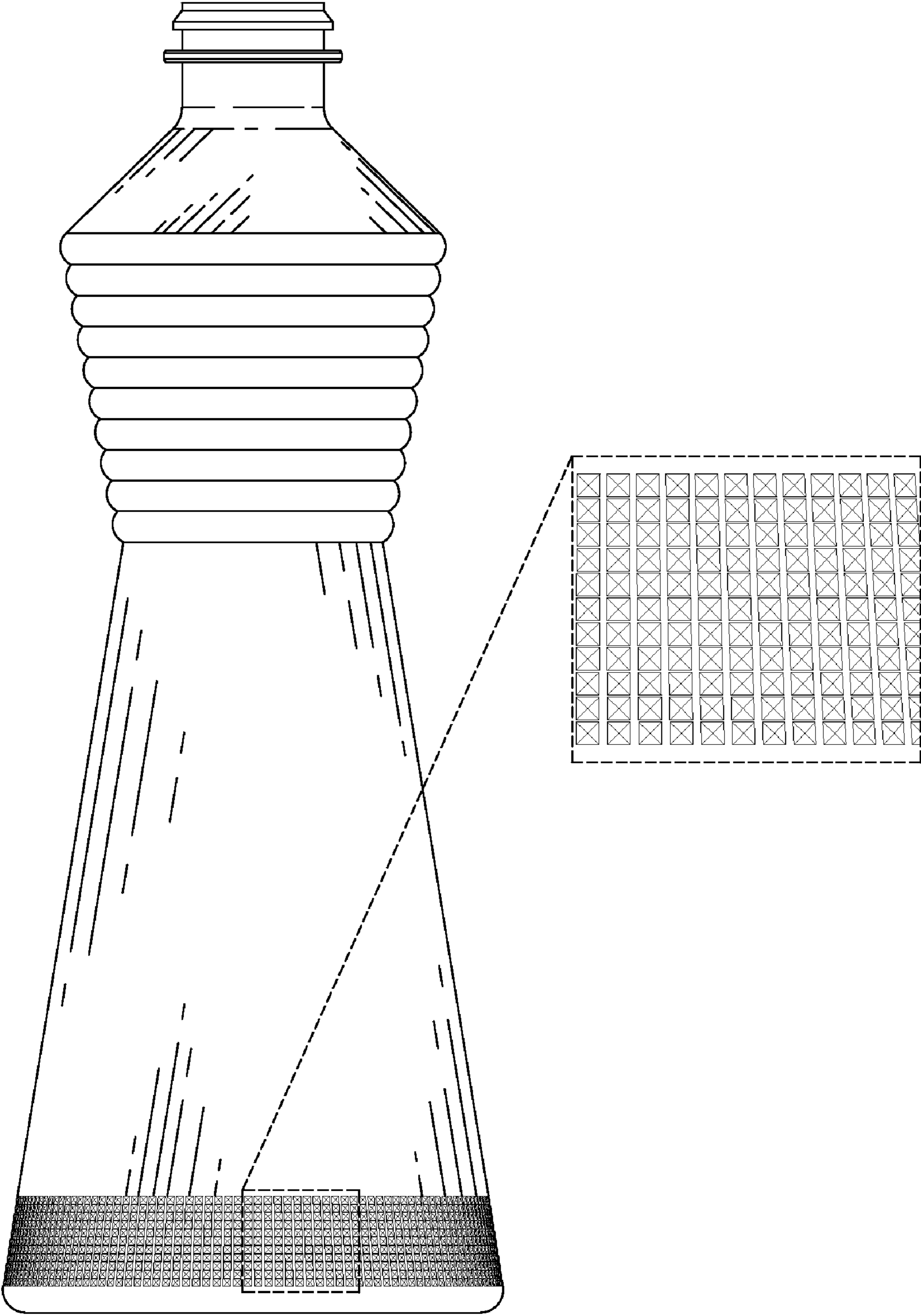
The broken lines shown in the drawings are included for the purpose of illustrating environmental structure that forms no part of the claimed design.

**1 Claim, 6 Drawing Sheets**

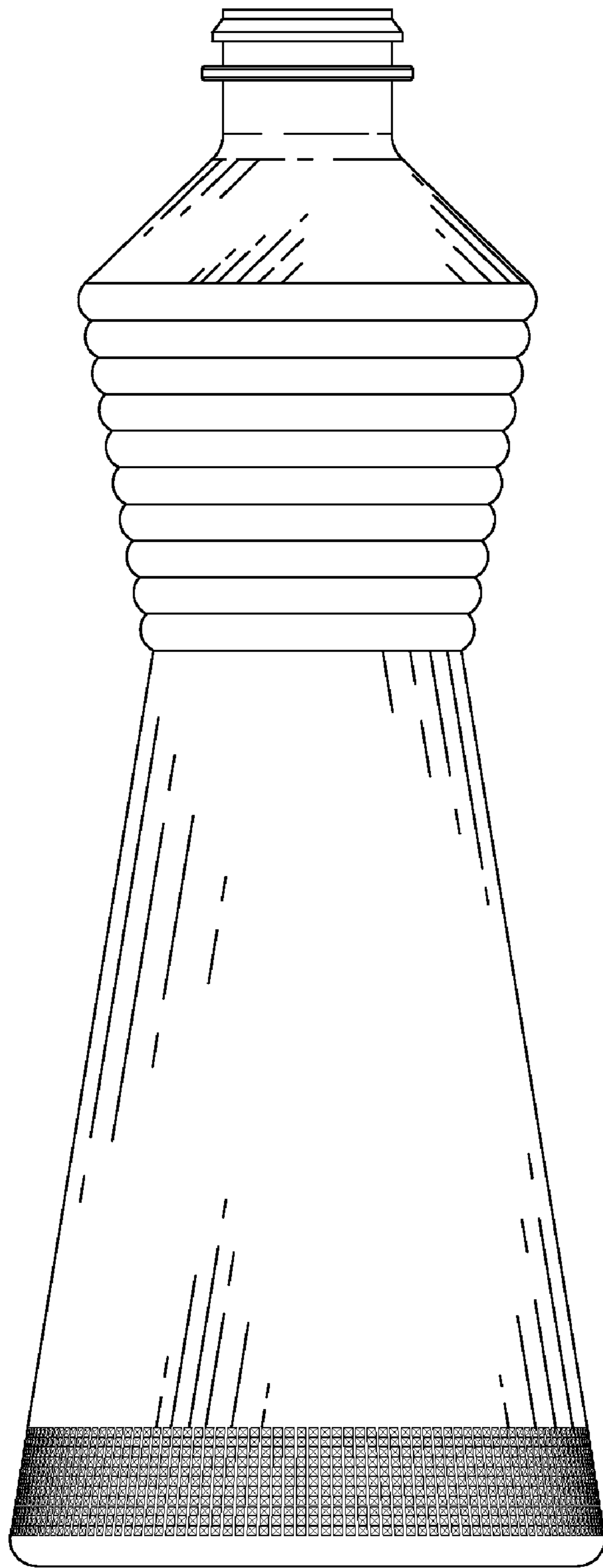




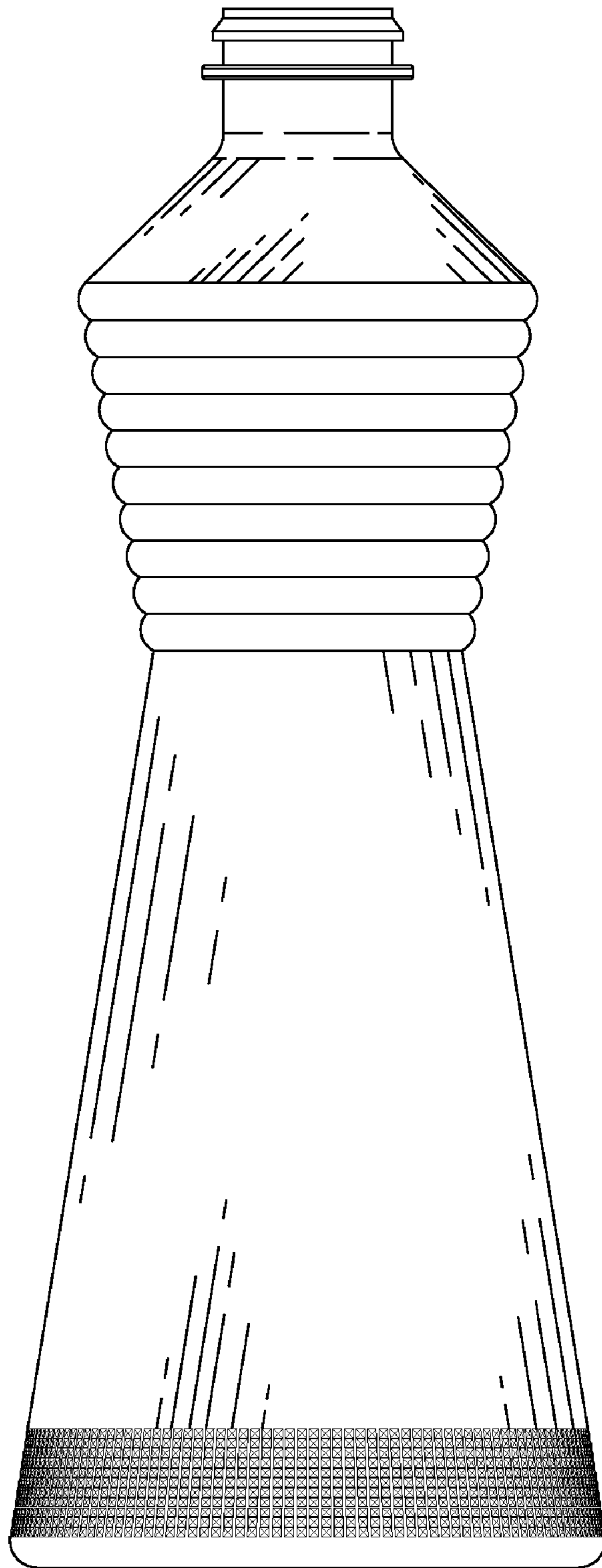
**FIG. 1**



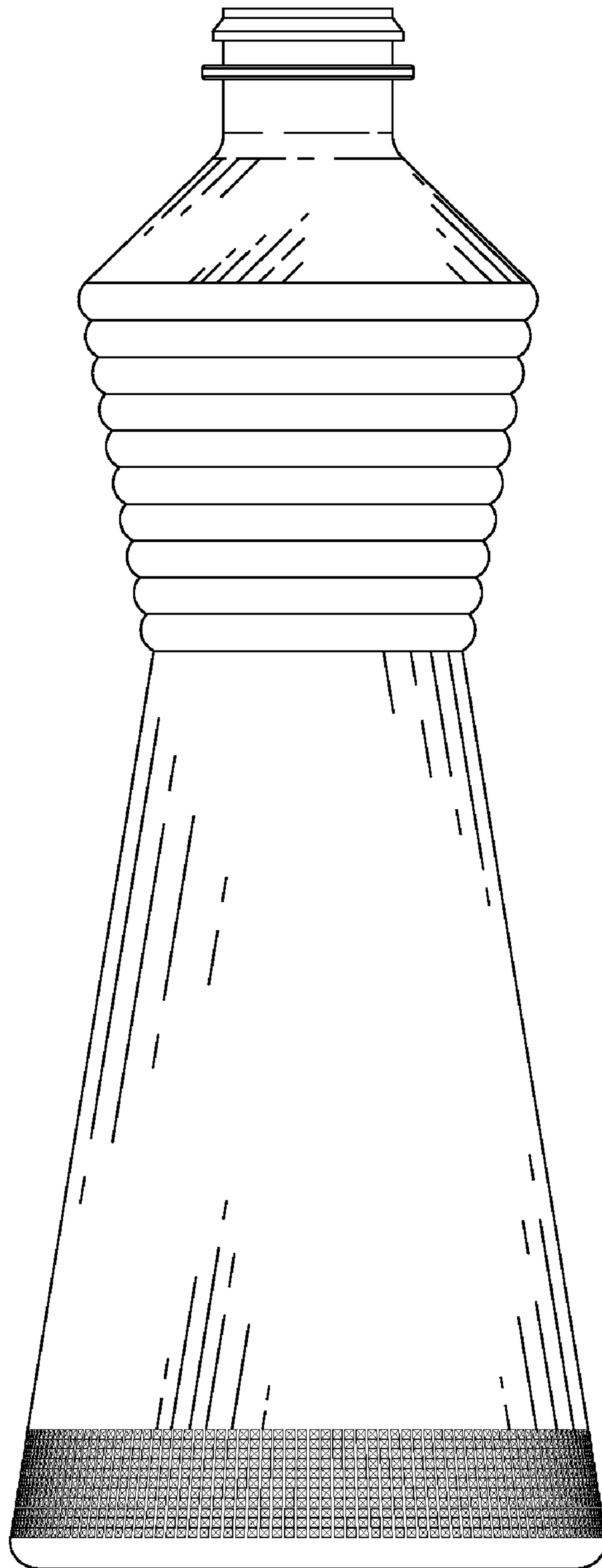
**FIG. 2**



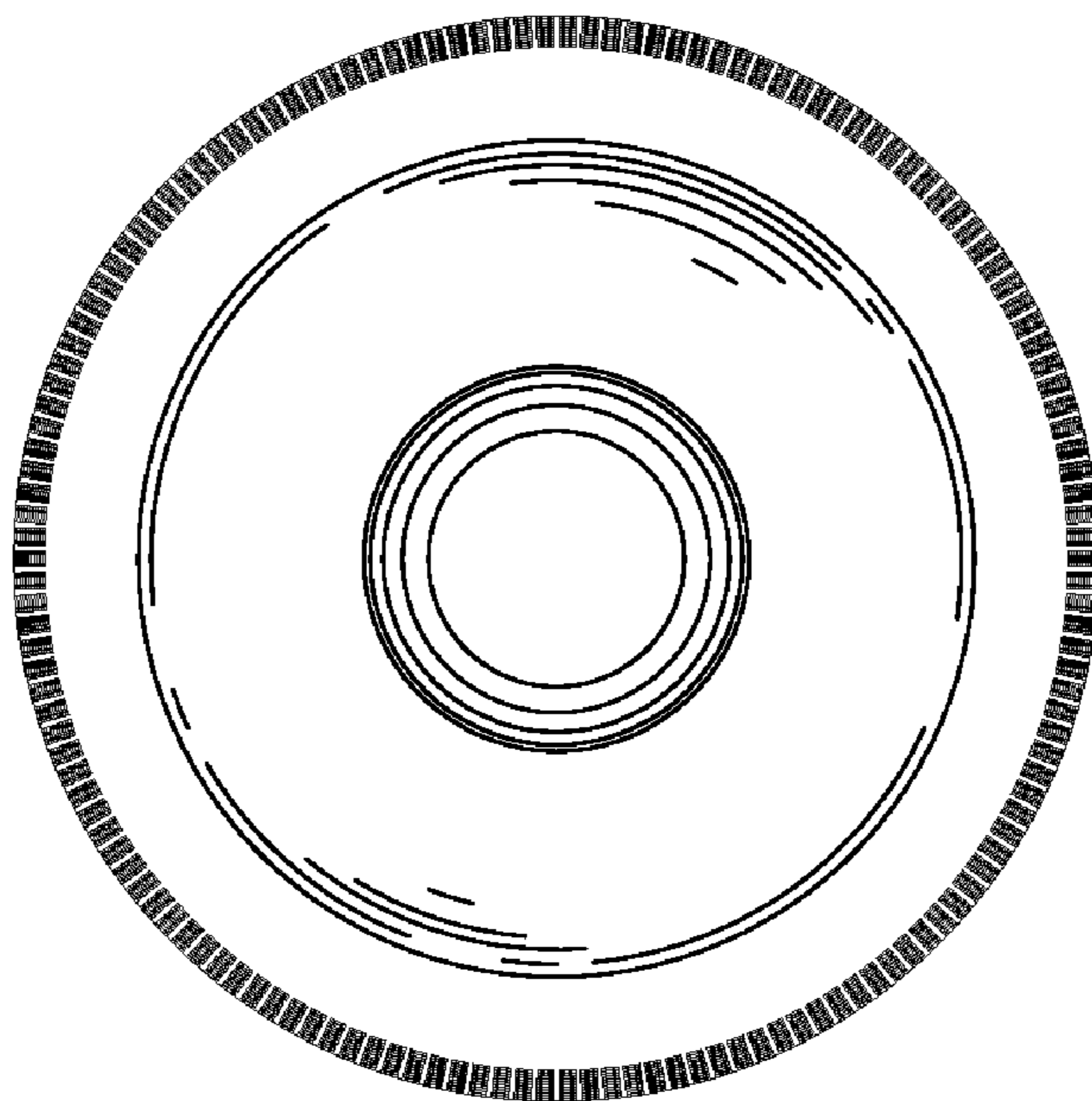
***FIG. 3***



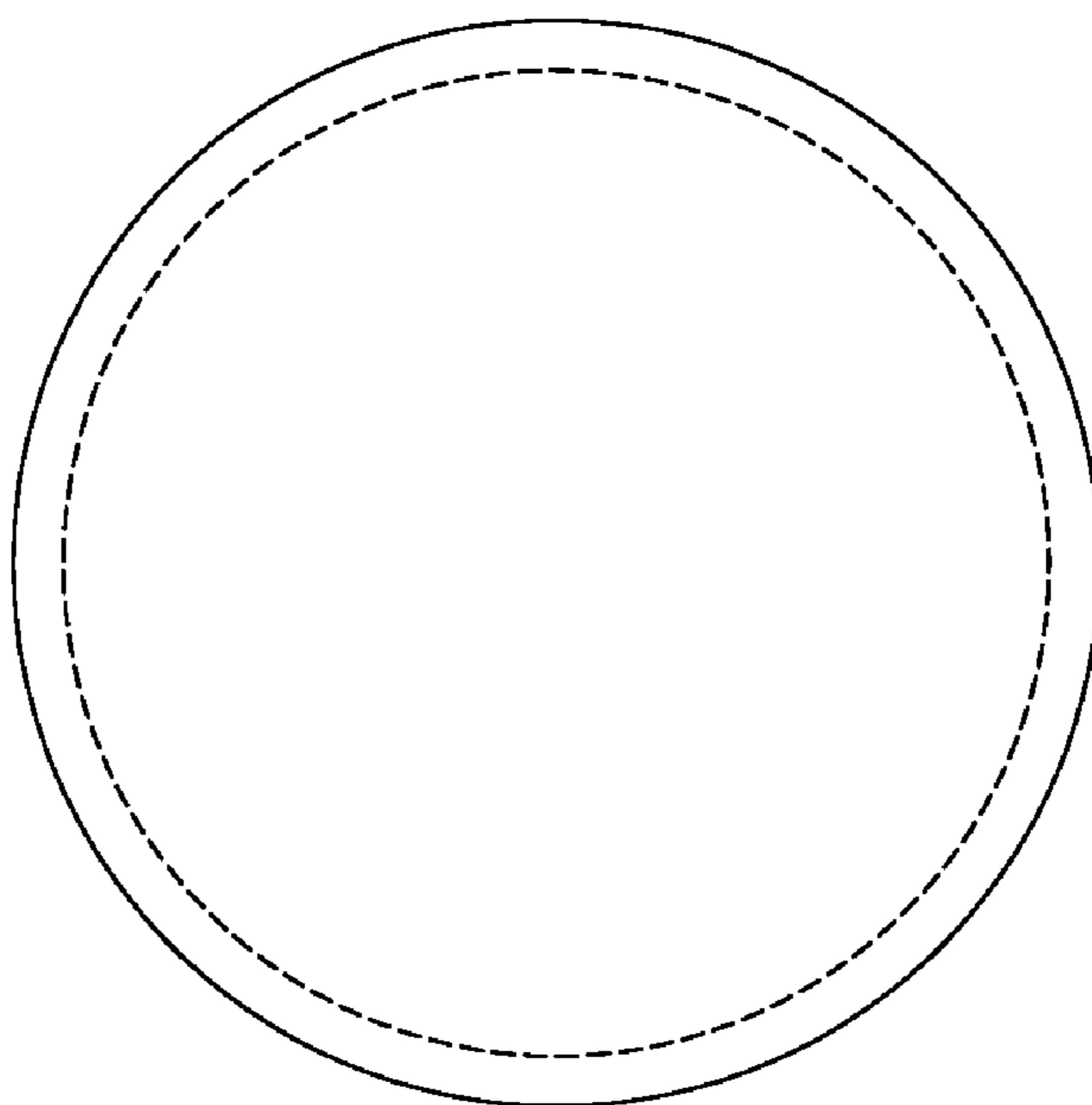
***FIG. 4***



***FIG. 5***



*FIG. 6*



*FIG. 7*