



US00D613234S

(12) **United States Design Patent**  
**Tirey et al.**

(10) **Patent No.:** **US D613,234 S**  
(45) **Date of Patent:** **\*\* Apr. 6, 2010**

(54) **HIGH DOME OVERHEAD CONSOLE OF A TRUCK VEHICLE**

(75) Inventors: **Robert Scott Tirey**, Fort Wayne, IN (US); **David L. Maher**, Fort Wayne, IN (US)

(73) Assignee: **Mahindra Navistar Automotives Limited** (IN)

(\*\*) Term: **14 Years**

(21) Appl. No.: **29/343,734**

(22) Filed: **Sep. 18, 2009**

(51) **LOC (9) Cl.** ..... **12-16**

(52) **U.S. Cl.** ..... **D12/418**

(58) **Field of Classification Search** ..... D12/415-426.1, D12/400, 195, 190, 345, 96, 99; 312/246; 296/37.1-37.8, 70, 24.1-24.3, 24.34; 224/311, 224/539, 281, 118.1, 188.5; 180/90; 439/34  
See application file for complete search history.

(56) **References Cited**

**U.S. PATENT DOCUMENTS**

- D225,987 S \* 1/1973 Stewart ..... D12/422
- D245,414 S \* 8/1977 Ashbaugh et al. .... D12/418
- D256,229 S \* 8/1980 Nichols ..... D12/418

- D259,633 S \* 6/1981 Butler ..... D12/418
- D281,930 S \* 12/1985 Engfer et al. .... D12/418
- D295,969 S \* 5/1988 Hooks et al. .... D12/424
- D314,739 S \* 2/1991 Mallone ..... D12/424
- D512,955 S \* 12/2005 Misch ..... D12/415
- D580,345 S \* 11/2008 Paxton et al. .... D12/418
- D589,871 S \* 4/2009 Bock ..... D12/345
- D592,585 S \* 5/2009 Moburg et al. .... D12/418

\* cited by examiner

*Primary Examiner*—Stacia Cadmus

(74) *Attorney, Agent, or Firm*—Jeffrey P. Calfa; Mark C. Bach; Gerald W. Askew

(57) **CLAIM**

The ornamental design for a high dome overhead console of a truck vehicle, as shown and described.

**DESCRIPTION**

FIG. 1 is a right, front perspective view of a high dome overhead console of a truck vehicle showing our new design; FIG. 2 is a right view thereof; FIG. 3 is a left view thereof; FIG. 4 is a front view thereof; and, FIG. 5 is a bottom view thereof.

**1 Claim, 2 Drawing Sheets**

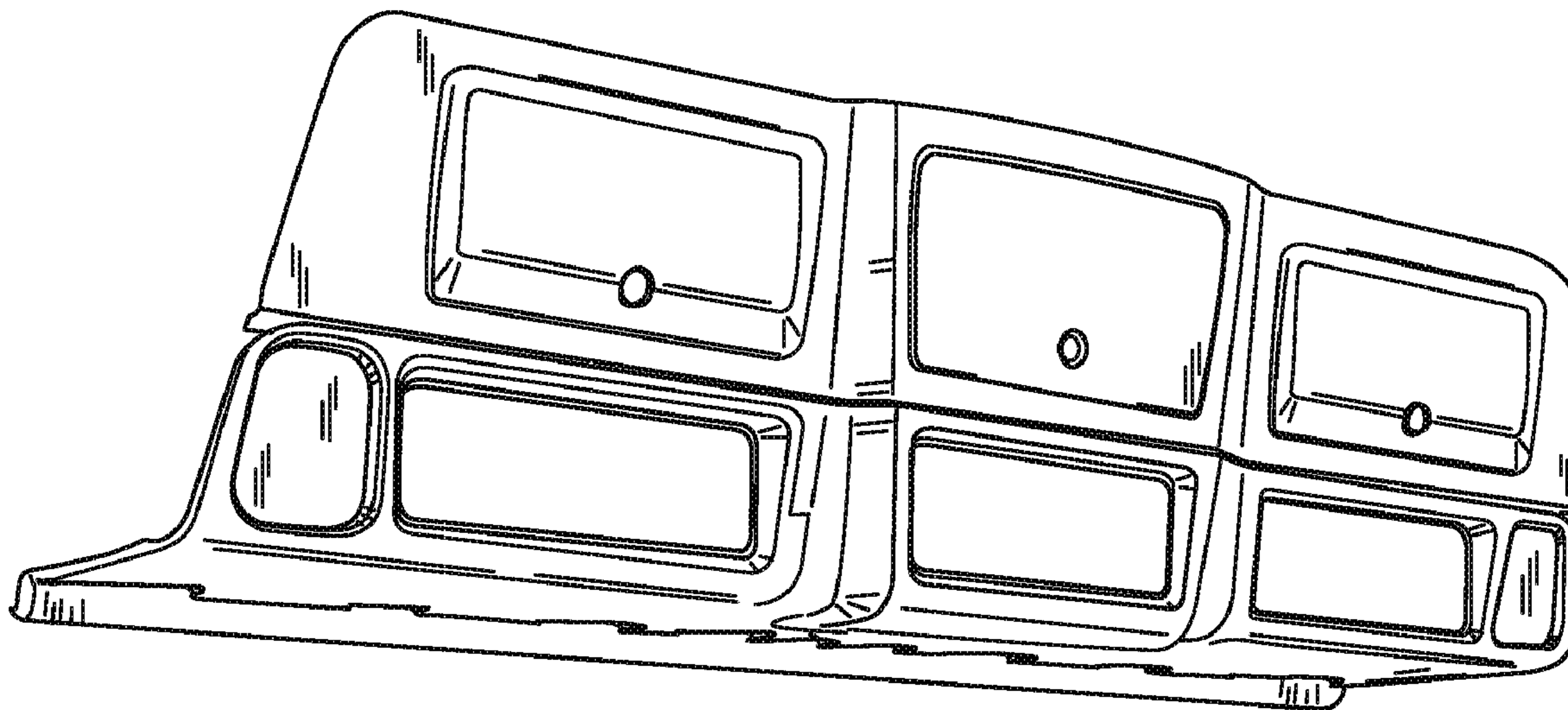

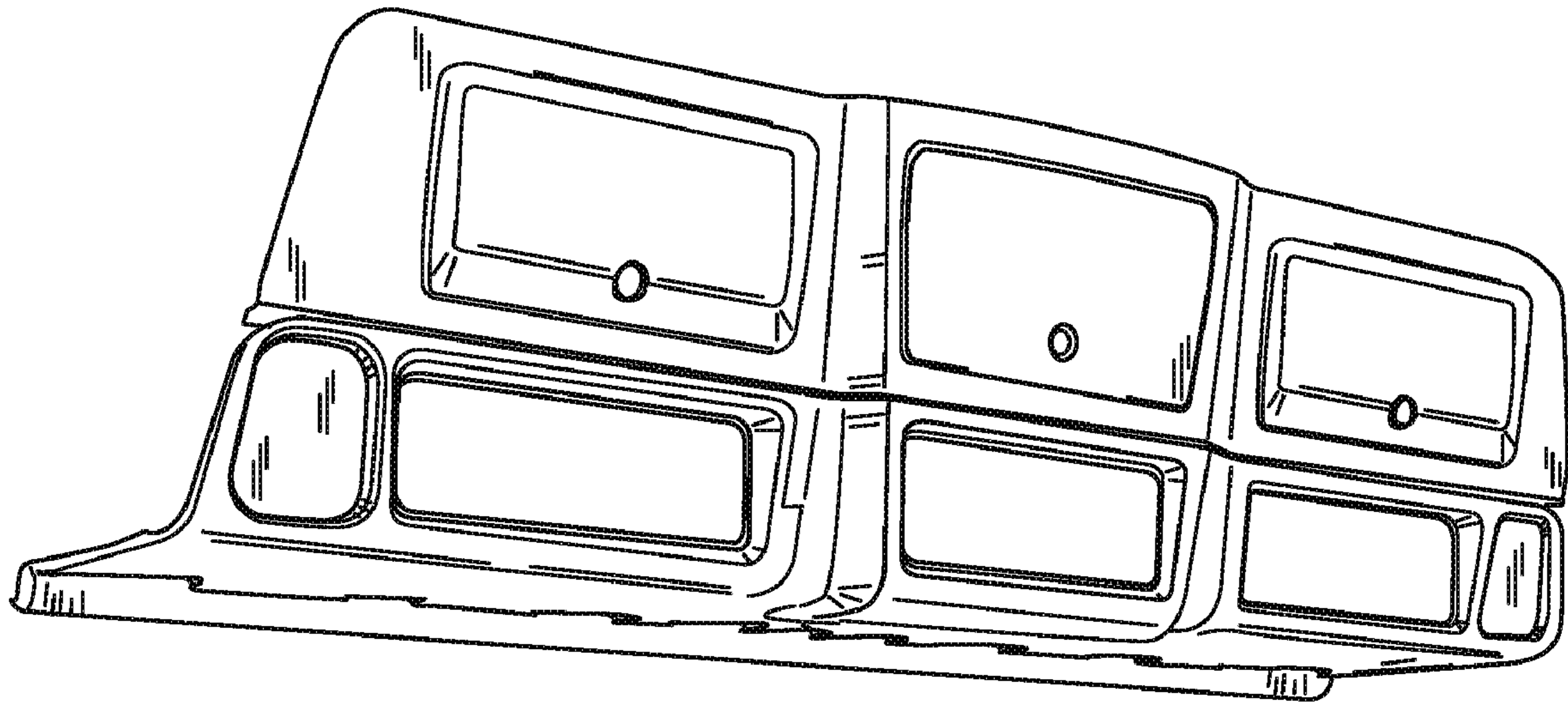

FIG. 1

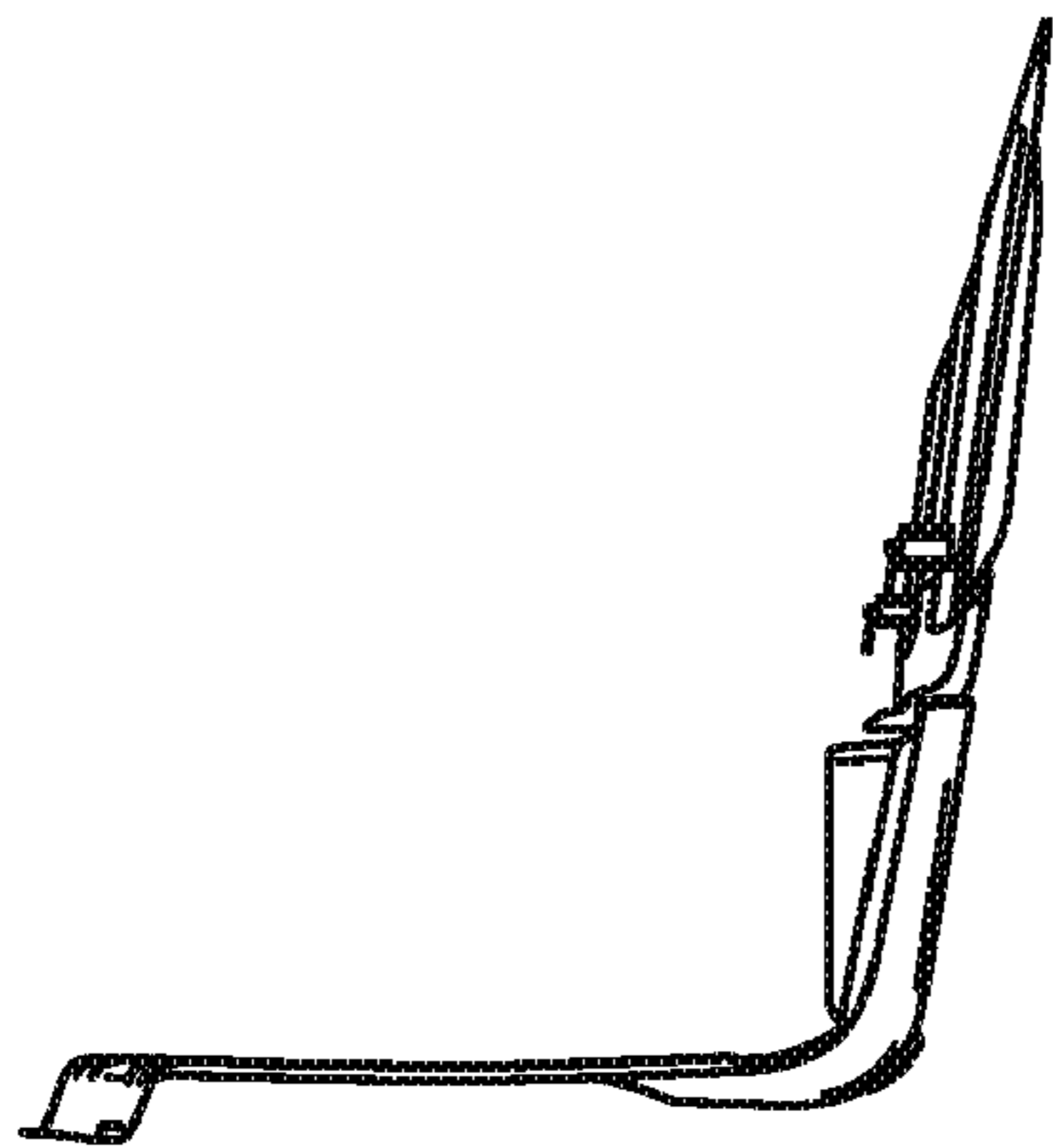

FIG. 2

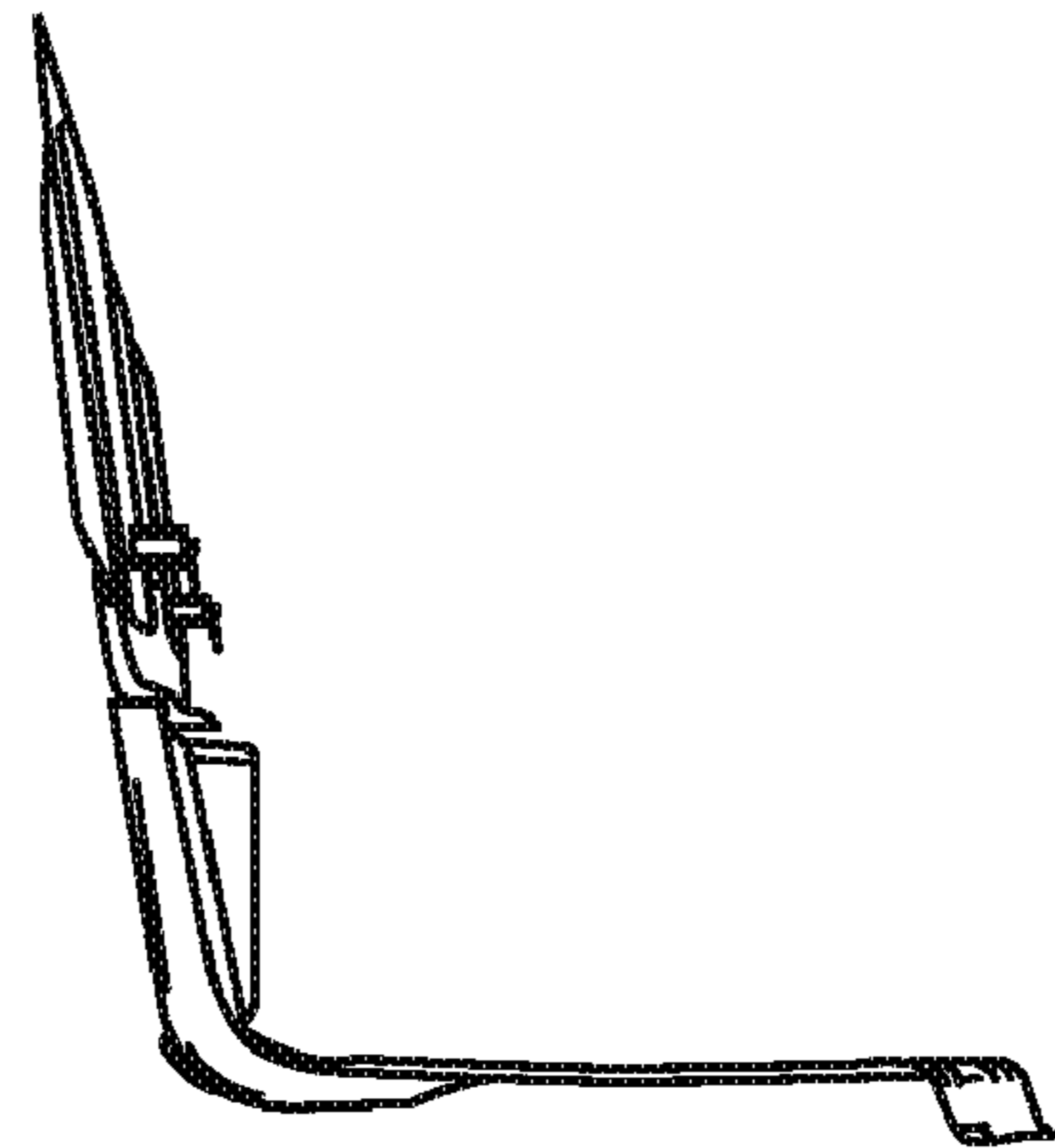

FIG. 3

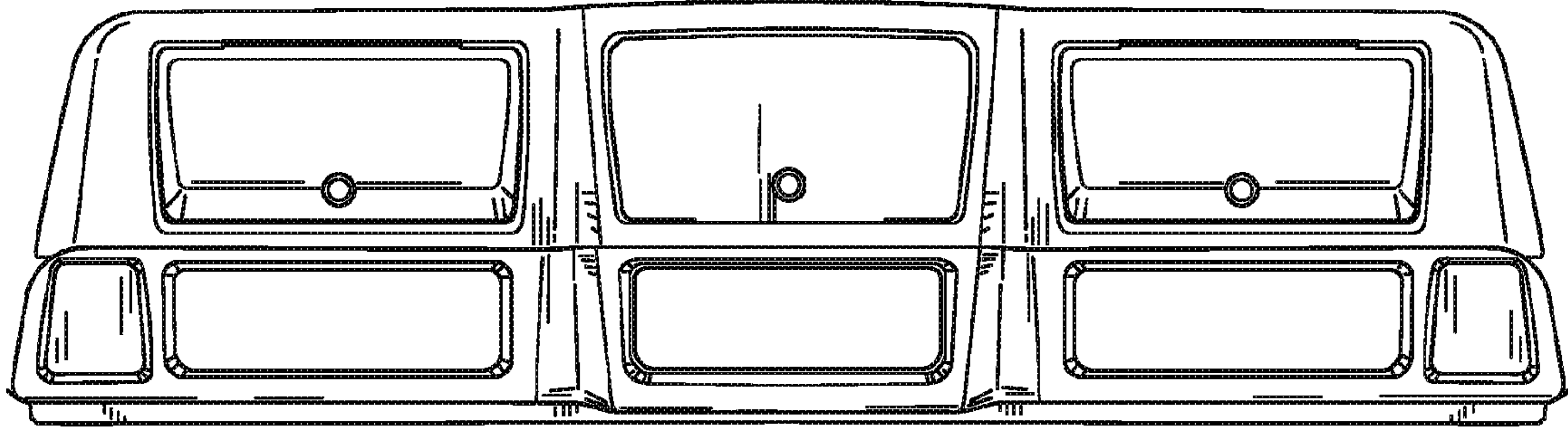

FIG. 4

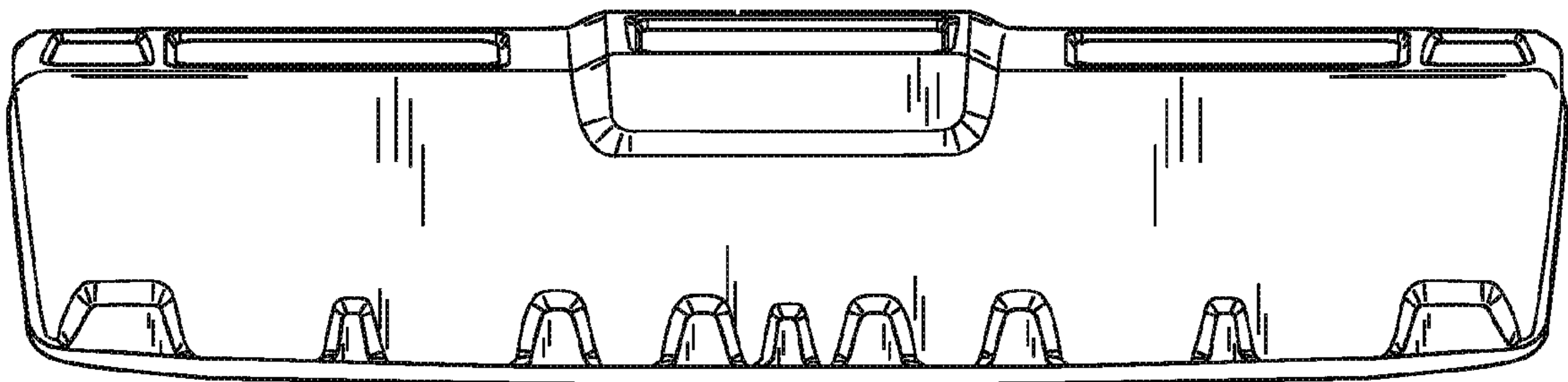

FIG. 5