



US00D613231S

(12) **United States Design Patent**
Anderson et al.

(10) **Patent No.:** **US D613,231 S**
(45) **Date of Patent:** **** Apr. 6, 2010**

(54) **LOW PROFILE VEHICLE WHEEL CHOCK BODY**

(75) Inventors: **John D. Anderson**, Oswego, IL (US);
Walter J. Peach, Montgomery, IL (US)

(73) Assignee: **Standard Car Truck Company**, Park Ridge, IL (US)

(**) Term: **14 Years**

(21) Appl. No.: **29/344,569**

(22) Filed: **Sep. 30, 2009**

(51) **LOC (9) Cl.** **12-06**

(52) **U.S. Cl.** **D12/217**

(58) **Field of Classification Search** D12/217,
D12/203, 400, 120, 180, 114; D8/402; 14/69.5,
14/71.5; 280/293, 507; 267/139-140; 410/30,
410/49; 211/20; 188/5, 32, 36; 186/32,
186/52; 248/346, 352, 221.12, 222.41, 222.51;
D34/35

See application file for complete search history.

(56) **References Cited**

U.S. PATENT DOCUMENTS

1,424,957 A 8/1922 Tilburg

(Continued)

FOREIGN PATENT DOCUMENTS

DE 1265771 4/1968

(Continued)

OTHER PUBLICATIONS

Pictures of Gaster Prototype "Chock," Publicly Available Prior to 2000, 7 pages.

Primary Examiner—Stacia Cadmus

(74) *Attorney, Agent, or Firm*—K&L Gates LLP

(57) **CLAIM**

The ornamental design for a low profile vehicle wheel chock body, as shown and described.

DESCRIPTION

FIG. 1 is a front perspective view of a low profile vehicle wheel chock body of one embodiment of our new design.

FIG. 2 is a top view of the low profile vehicle wheel chock body of FIG. 1.

FIG. 3 is a bottom view of the low profile vehicle wheel chock body of FIG. 1.

FIG. 4 is a right side view of the low profile vehicle wheel chock body of FIG. 1.

FIG. 5 is a left side view of the low profile vehicle wheel chock body of FIG. 1.

FIG. 6 is a front end view of the low profile vehicle wheel chock body of FIG. 1.

FIG. 7 is a back end view of the low profile vehicle wheel chock body of FIG. 1.

FIG. 8 is a front perspective view of a low profile vehicle wheel chock body of another embodiment of our new design.

FIG. 9 is a top view of the low profile vehicle wheel chock body of FIG. 8.

FIG. 10 is a bottom view of the low profile vehicle wheel chock body of FIG. 8.

FIG. 11 is a right side view of the low profile vehicle wheel chock body of FIG. 8.

FIG. 12 is a left side view of the low profile vehicle wheel chock body of FIG. 8.

FIG. 13 is a front end view of the low profile vehicle wheel chock body of FIG. 8; and,

FIG. 14 is a back end view of the low profile vehicle wheel chock body of FIG. 8.

In the drawings, the broken lines do not form part of the claimed design.

1 Claim, 8 Drawing Sheets

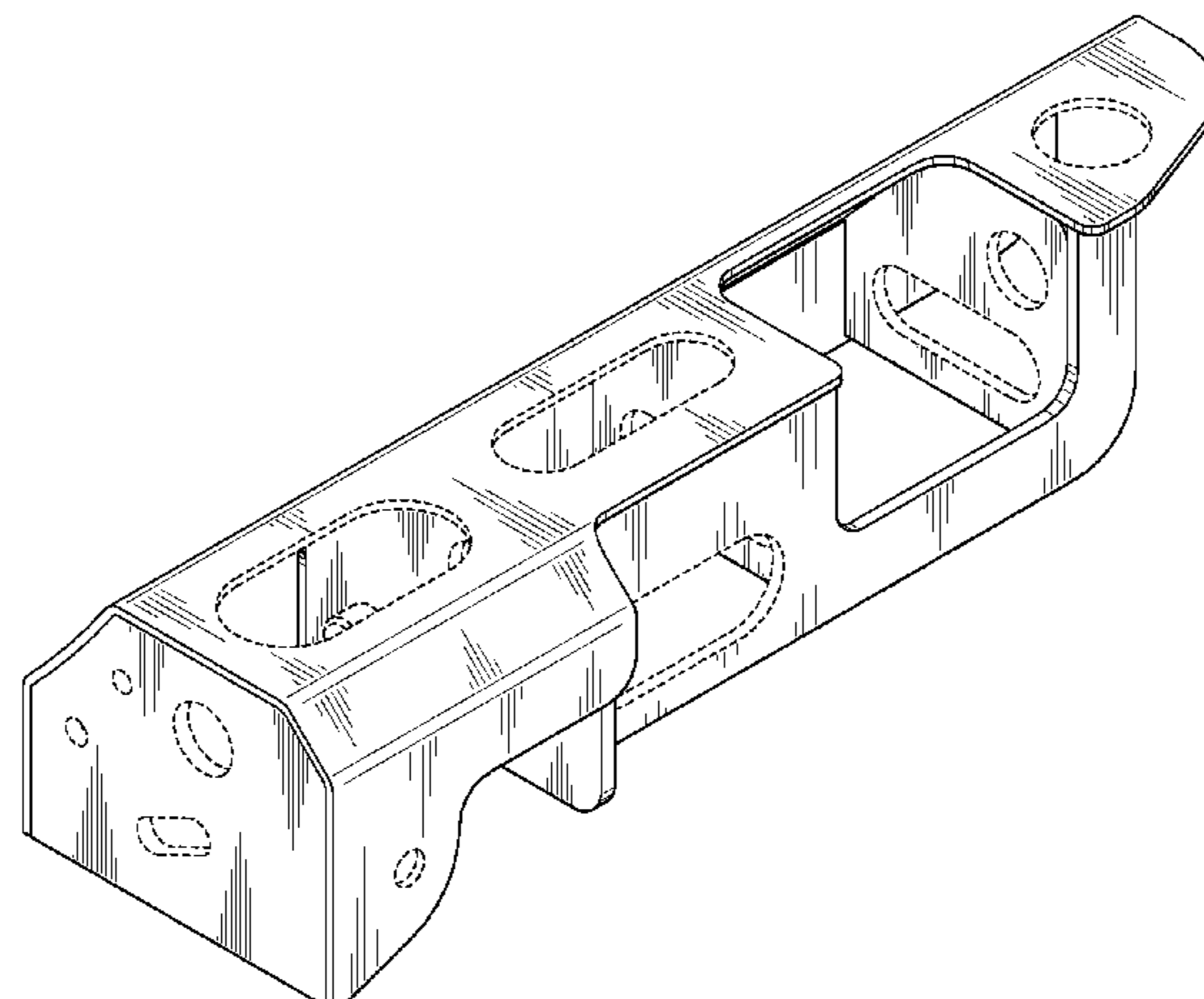

US D613,231 S

Page 2

U.S. PATENT DOCUMENTS

1,776,935	A	9/1930	Snyder	
2,066,714	A	1/1937	Butterworth	
2,540,400	A	2/1951	McHenry	
2,705,081	A	3/1955	Jacobs	
2,730,400	A	1/1956	Francis	
2,771,162	A	11/1956	Marsh	
2,797,774	A	7/1957	Eckhart	
2,853,257	A	9/1958	Cook	
2,858,905	A	11/1958	Fahland	
2,895,569	A	7/1959	Nystrom	
3,119,350	A	1/1964	Bellingher	
3,581,846	A	6/1971	Janus	
3,605,954	A	9/1971	Wakabayashi, et al.	
3,739,906	A	6/1973	Cwycyshyn, et al.	
3,895,587	A	7/1975	Bell	
4,024,820	A	5/1977	Hlinsky et al.	
4,031,983	A	6/1977	Lentini	
4,032,167	A	6/1977	Chereda	
4,060,036	A	11/1977	Palms	
4,316,686	A	2/1982	Cottrell et al.	
4,343,401	A	8/1982	Paulyson	
4,399,893	A	8/1983	Switzer	
D281,063	S *	10/1985	De Raad D12/217
4,615,416	A	10/1986	Wilson	
4,654,266	A	3/1987	Kachnik	
4,668,140	A	5/1987	Blunden	
4,676,344	A	6/1987	Locicero	
4,695,087	A	9/1987	Hollrock	
4,786,223	A	11/1988	Crissy et al.	
4,804,070	A	2/1989	Bohler	
4,836,726	A	6/1989	Robertson et al.	
4,838,743	A	6/1989	Blunden et al.	
4,875,813	A	10/1989	Moyer et al.	
4,960,353	A	10/1990	Thorndyke	
4,971,492	A	11/1990	Moyer et al.	
5,037,255	A	8/1991	Bullock et al.	

5,106,245	A	4/1992	Fritz et al.	
5,160,223	A	11/1992	Seitz	
5,302,063	A	4/1994	Winsor	
5,312,213	A	5/1994	Winsor	
5,316,421	A	5/1994	Bullock et al.	
D402,616	S *	12/1998	Henry D12/217
D415,463	S *	10/1999	Henry D12/217
D420,640	S *	2/2000	Henry D12/217
D422,960	S *	4/2000	Henry D12/217
6,164,893	A	12/2000	Glomot et al.	
D474,729	S *	5/2003	Sargent D12/217
D489,310	S *	5/2004	Olson et al. D12/217
6,835,034	B2	12/2004	Winsor	
6,851,523	B1	2/2005	Gaster	
6,926,480	B2	8/2005	Anderson et al.	
D511,734	S *	11/2005	Moore et al. D12/217
D516,268	S	2/2006	Gaster	
7,004,696	B2	2/2006	Anderson et al.	
7,128,508	B2	10/2006	Anderson et al.	
7,150,592	B2	12/2006	Anderson et al.	
D543,926	S *	6/2007	Kutzler D12/217
D547,712	S *	7/2007	Hartmann D12/217
D587,183	S *	2/2009	Blumenthal et al. D12/217
7,513,725	B1	4/2009	Bullock	
2009/0208304	A1	8/2009	Bullock et al.	

FOREIGN PATENT DOCUMENTS

DE	1810854	7/1971
DE	2519885 A1	11/1976
EP	0128992 A1	12/1984
FR	1564196	4/1969
FR	2296550	11/1974
FR	2421768	11/1979
FR	2584664 A1	1/1987
SU	1243985 A1	7/1986
WO	WO 8909709	10/1989

* cited by examiner

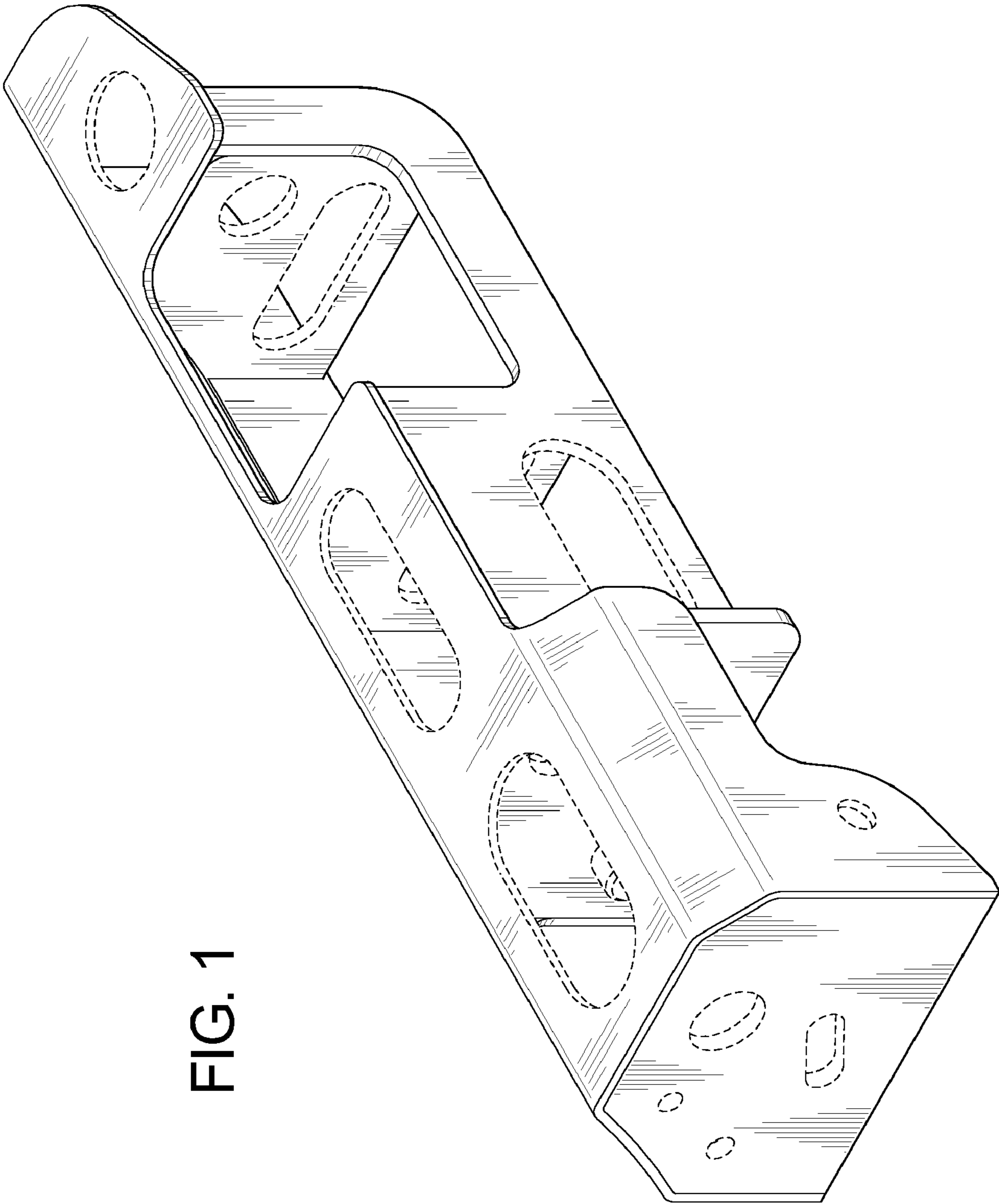

FIG. 1

FIG. 2

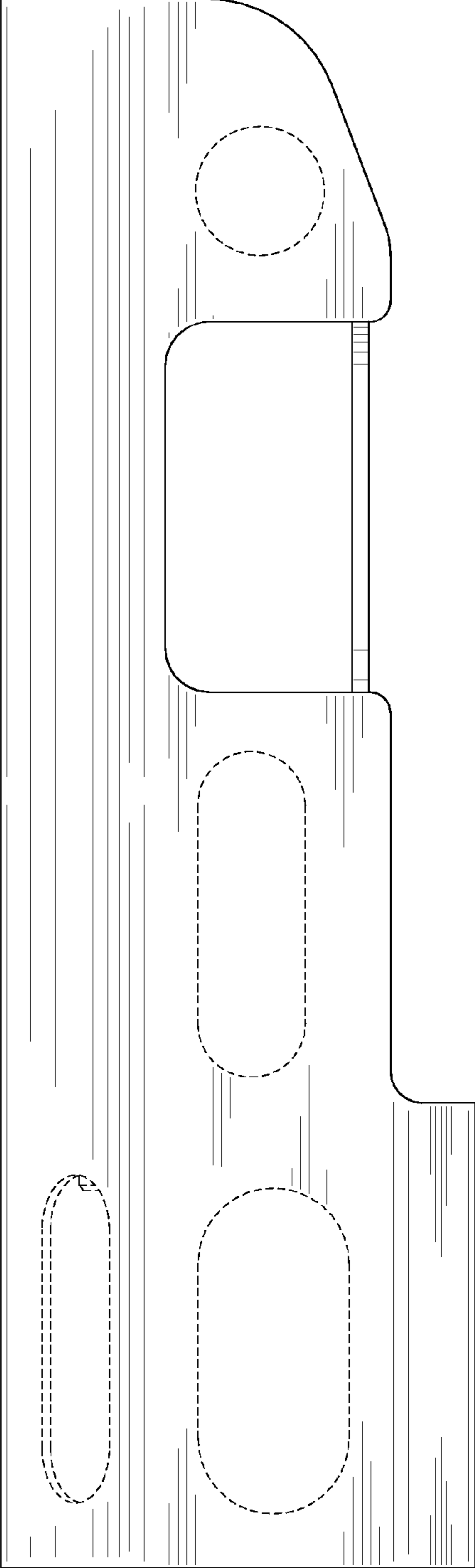

FIG. 3

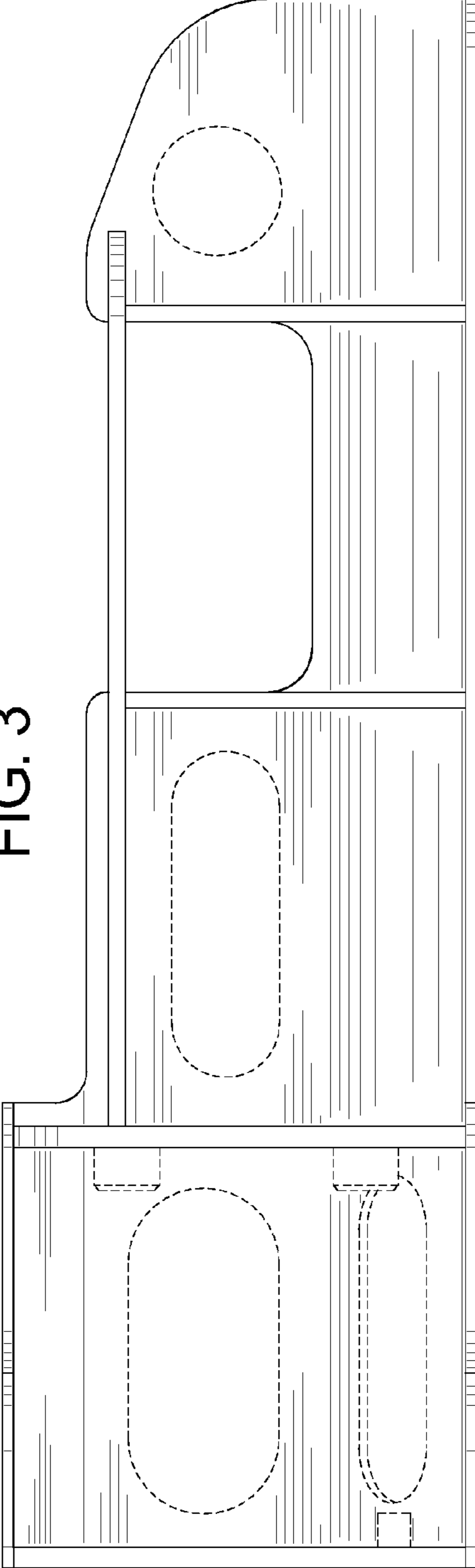

FIG. 4

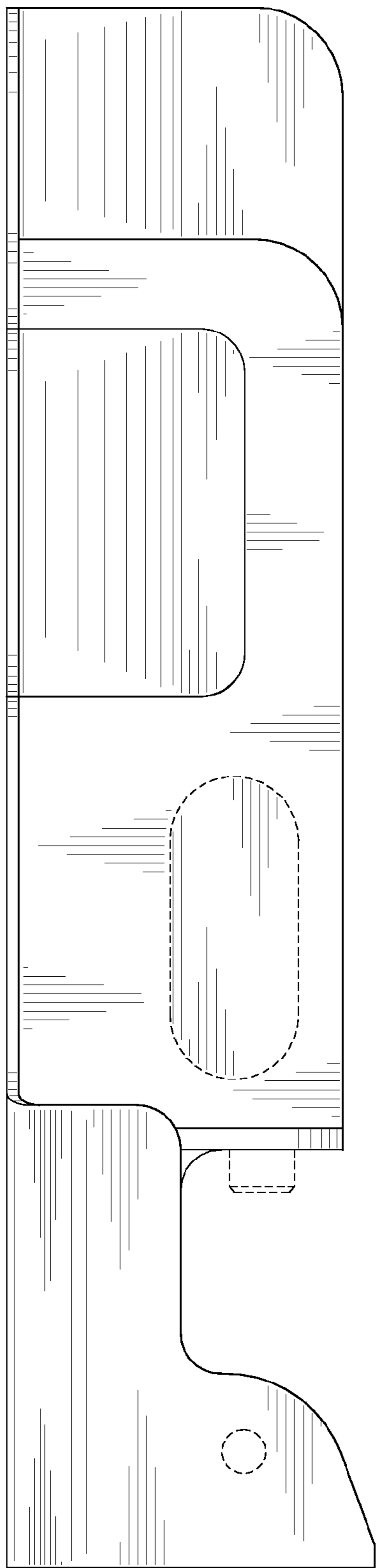

FIG. 5

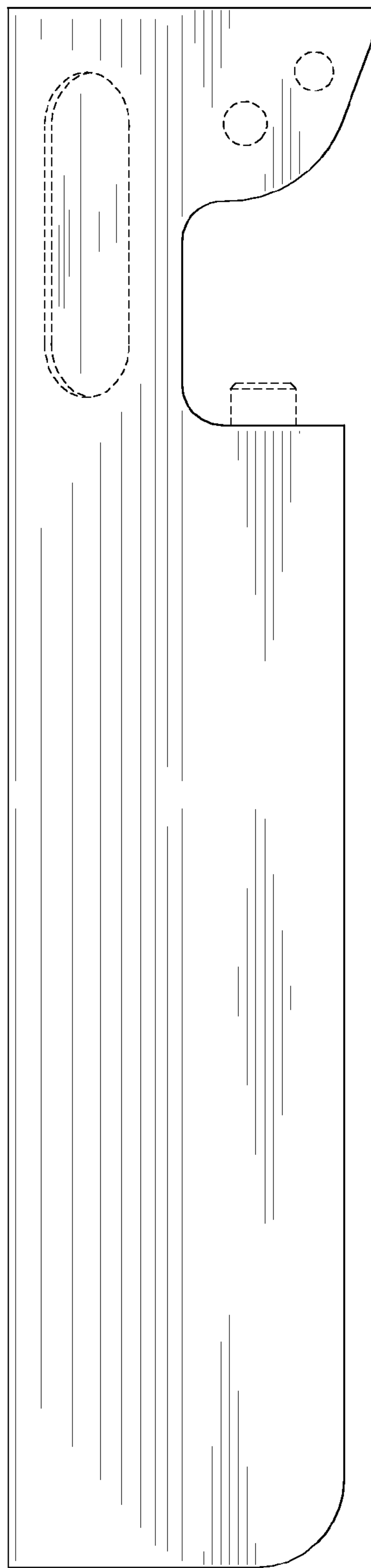

FIG. 6

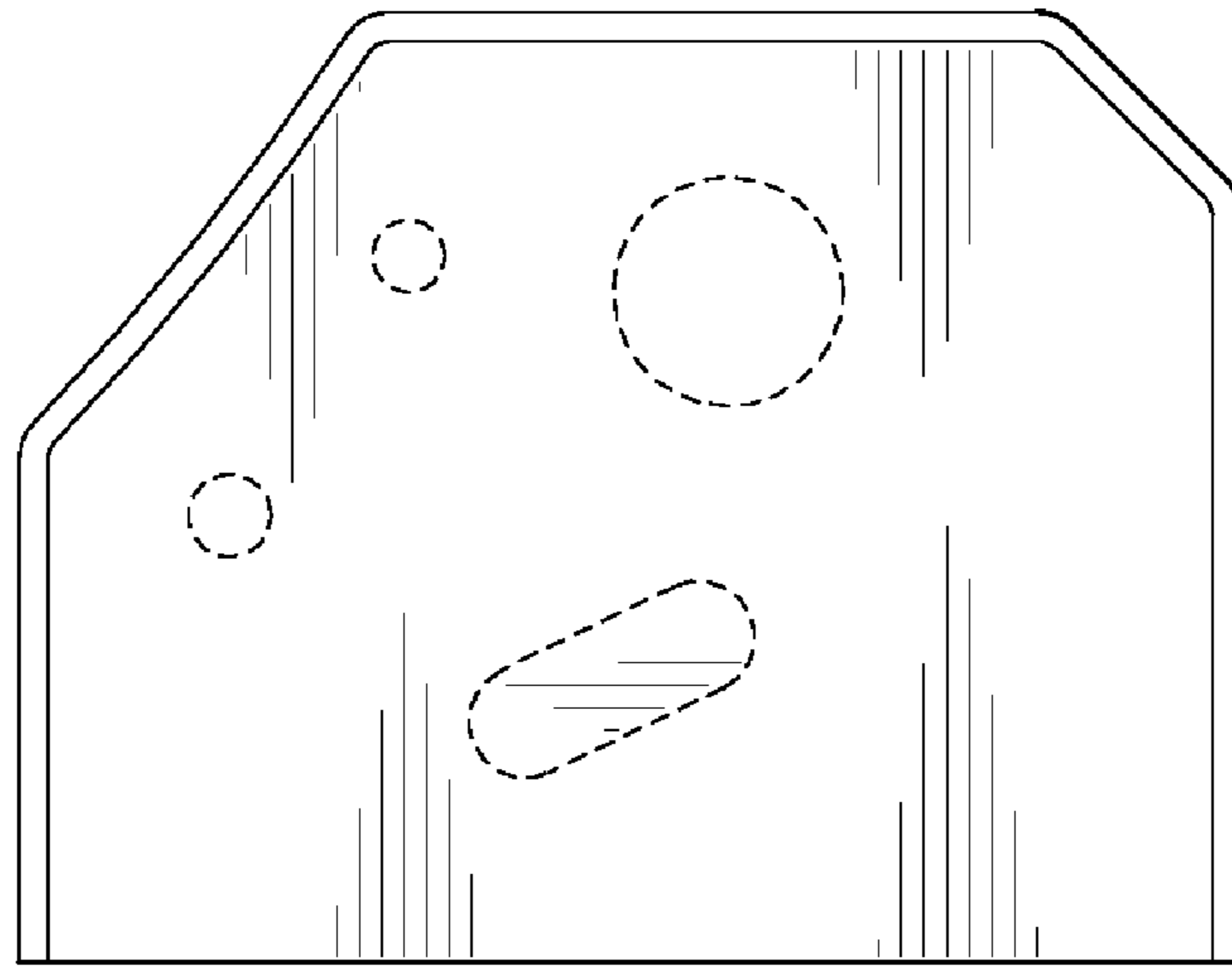
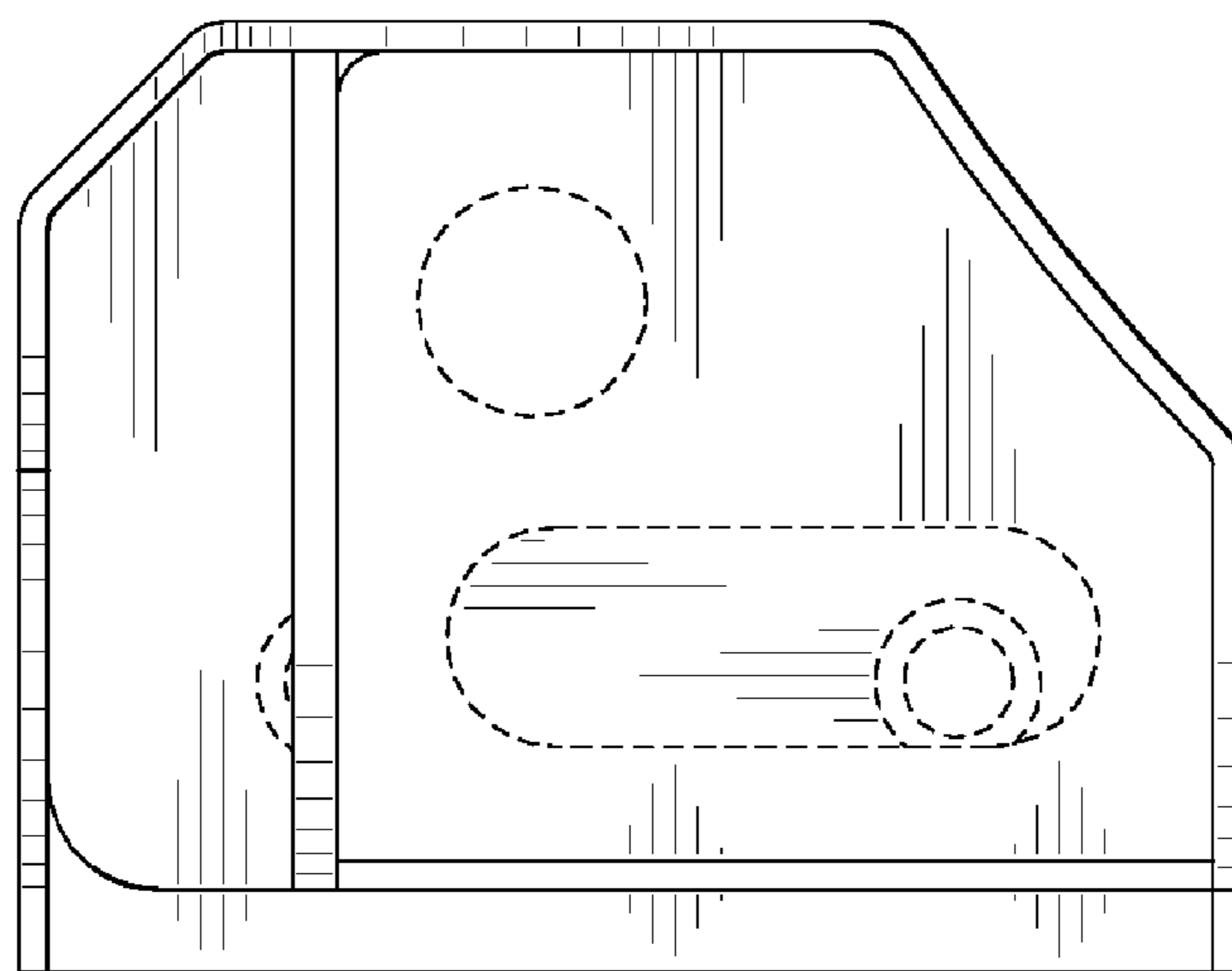

FIG. 7



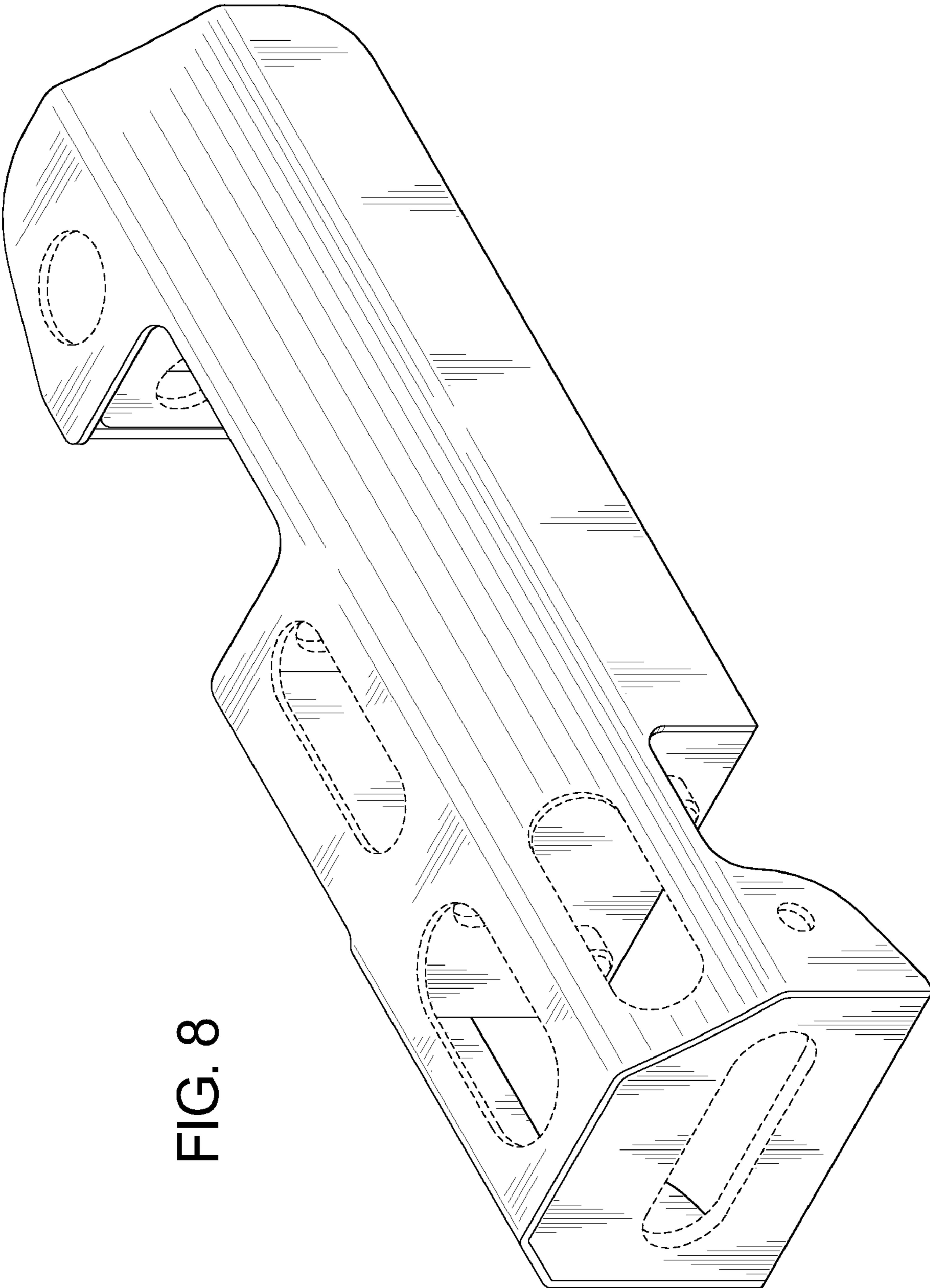

FIG. 8

FIG. 9

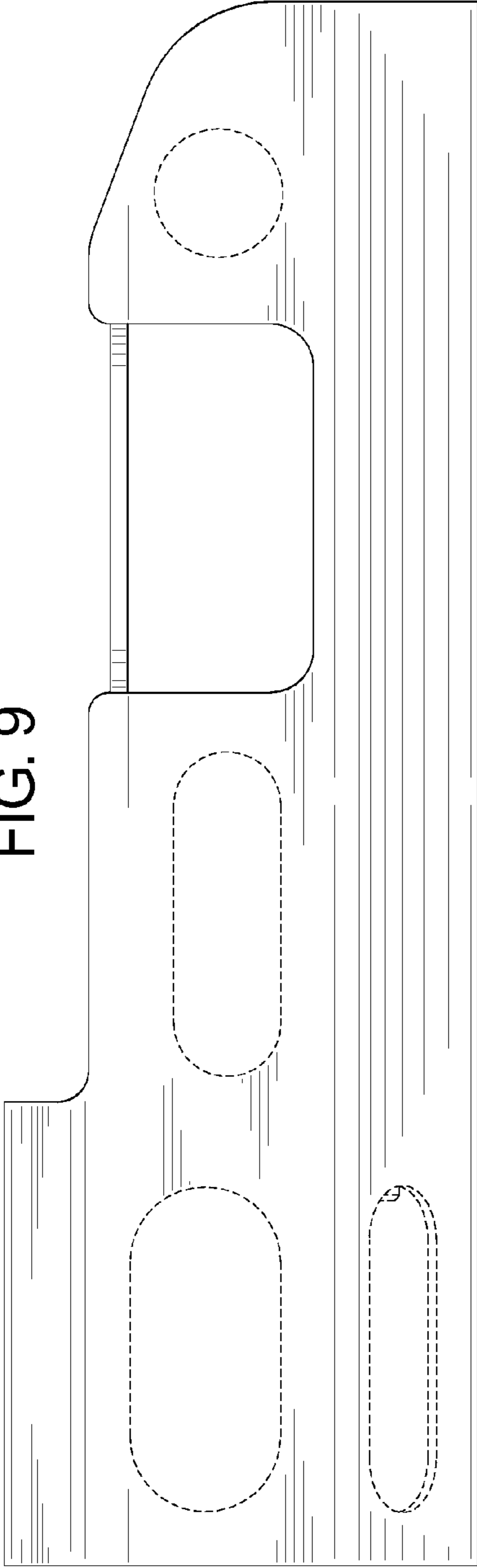

FIG. 10

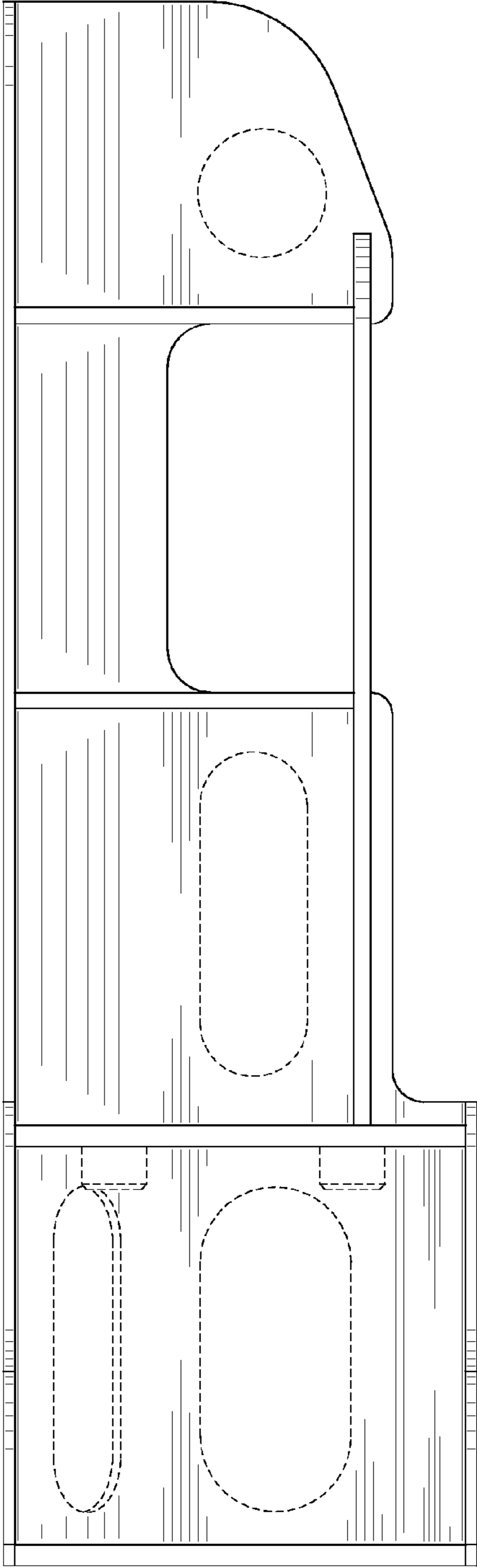

FIG. 11

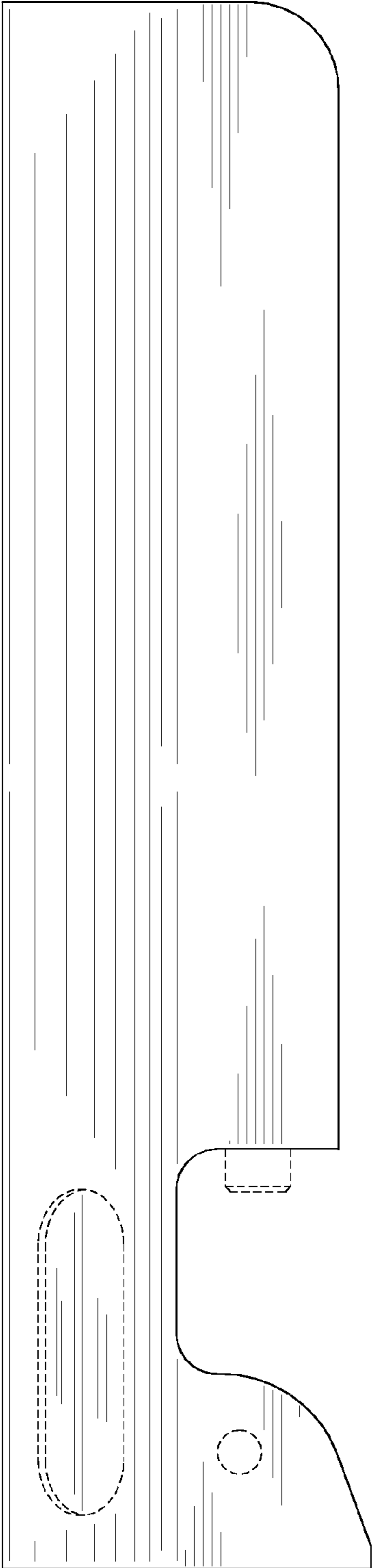

FIG. 12

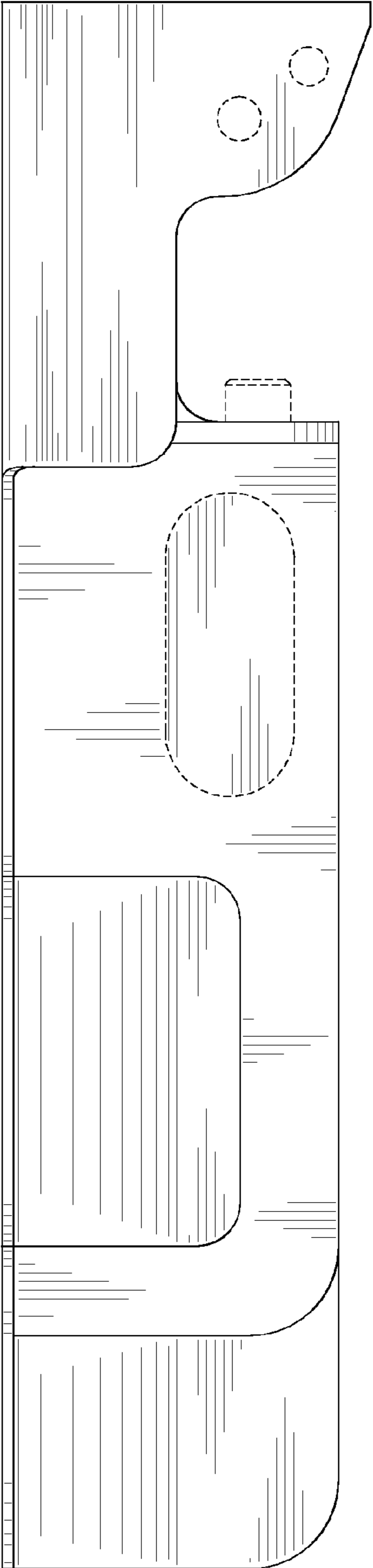

FIG. 13

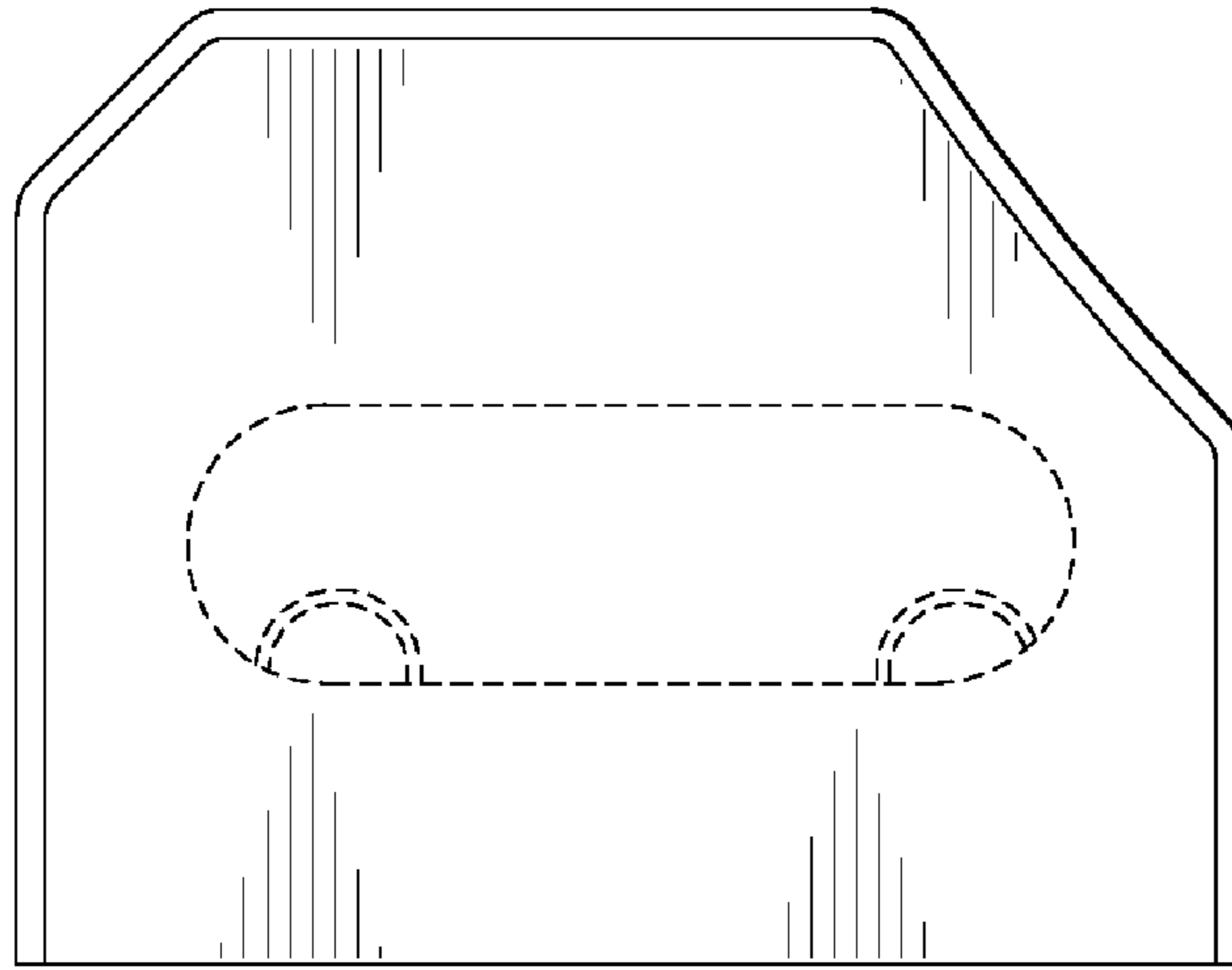

FIG. 14

